

第 01 图 发动机装置

FIG.01 ENGINE MOUNT

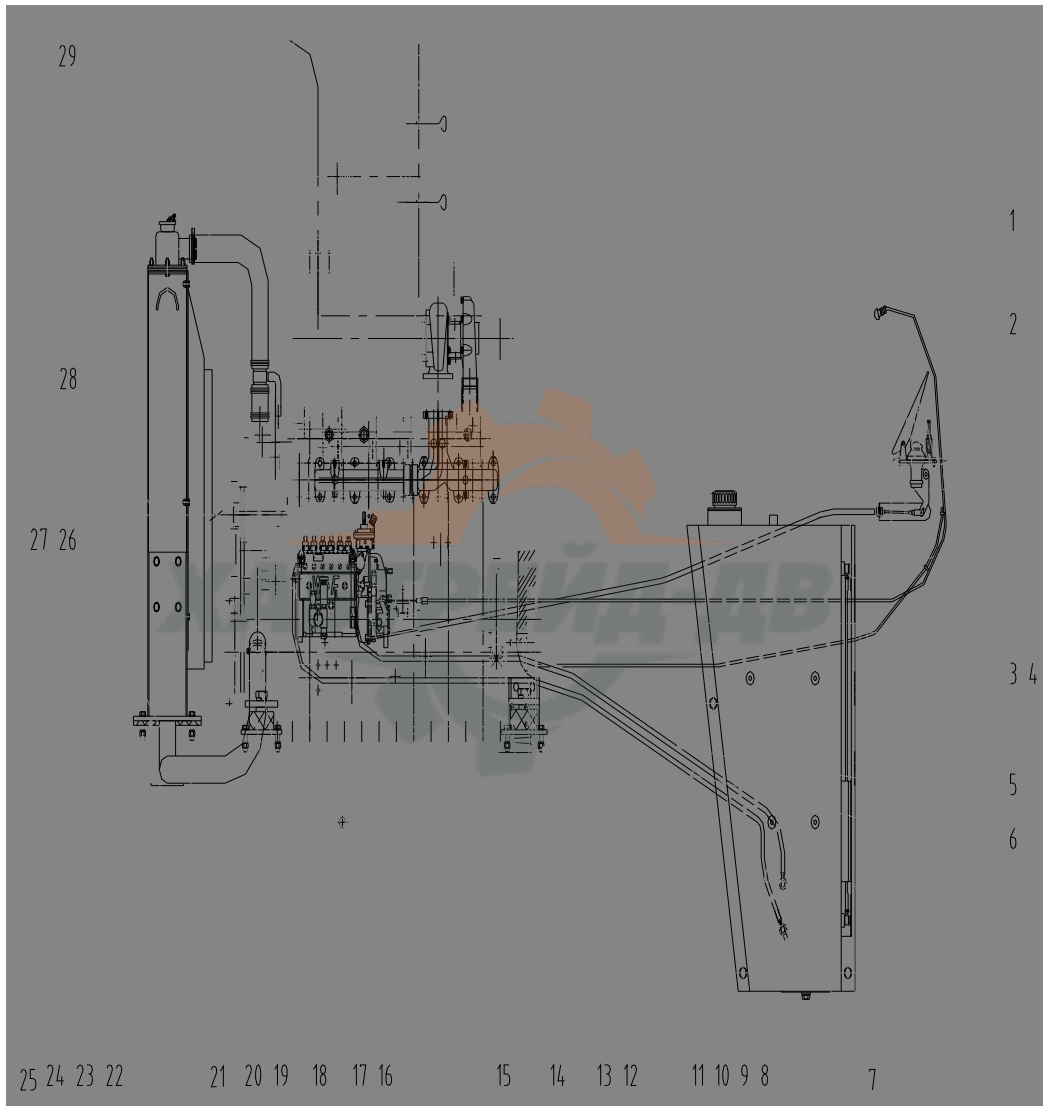

发动机装置

ENGINE MOUNT

序号 Index No.	件 号 Part No.	名 称 Description	数量 Q'ty	
01—1	CA10B	熄火软轴	Extinguishing cable	1
2	XZ(QZ)1129001	油门操纵阀	Accelerator control valve	1
3	ZL30G-12025	锥堵接头	Fitting	1
4	ZL30E-01032C	油管	Fuel tube	1
5	ZL30E-01013B	燃油回油管	Return fuel tube	1
6	GB3452-83	燃油吸油管	Suction fuel tube	1
7	ZL30E-01200	燃油箱	Fuel tank	1
8	GB6170-86	螺母 M14	Nut	12
9	GB93-87	垫圈 14	Washer	12
10	GB95-85	垫圈 14	Washer	12
11	GB5781-86	螺栓 M14×50	Blot	12
12	GB5783-86	螺栓 M24×55	Blot	2
13	GB93-87	垫圈 24	Washer	2
14	EA-300	减振器	Damping pad	2
15	TD226B	柴油机	Diesel engine	1
16	GB5783-86	螺栓 M22×55	Blot	2
17	GB93-87	垫圈 22	Washer	2
18	EA-220	减振器	Damping pad	2
19		胶管	Tube	1
20		双钢丝卡箍 57-62	Clamp	8
21	ZL30E-01019	胶垫	Damping space	2
22	GB5781-86	螺栓 M12×55	Blot	4
23	GB93-87	垫圈 12	Washer	4
24	GB6170-86	螺母 M12	Nut	4
25	GB95-85	垫圈 12	Washer	4
26	DG930B-01018D	胶管	Tube	1
27		钢管总成	Steel tube assembly	1
28		水箱	Radiator	1
29	DG930B-01021D	胶管	Tube	1

第 02 图 燃油箱总成

FIG.02 FUEL TANK ASSEMBLY

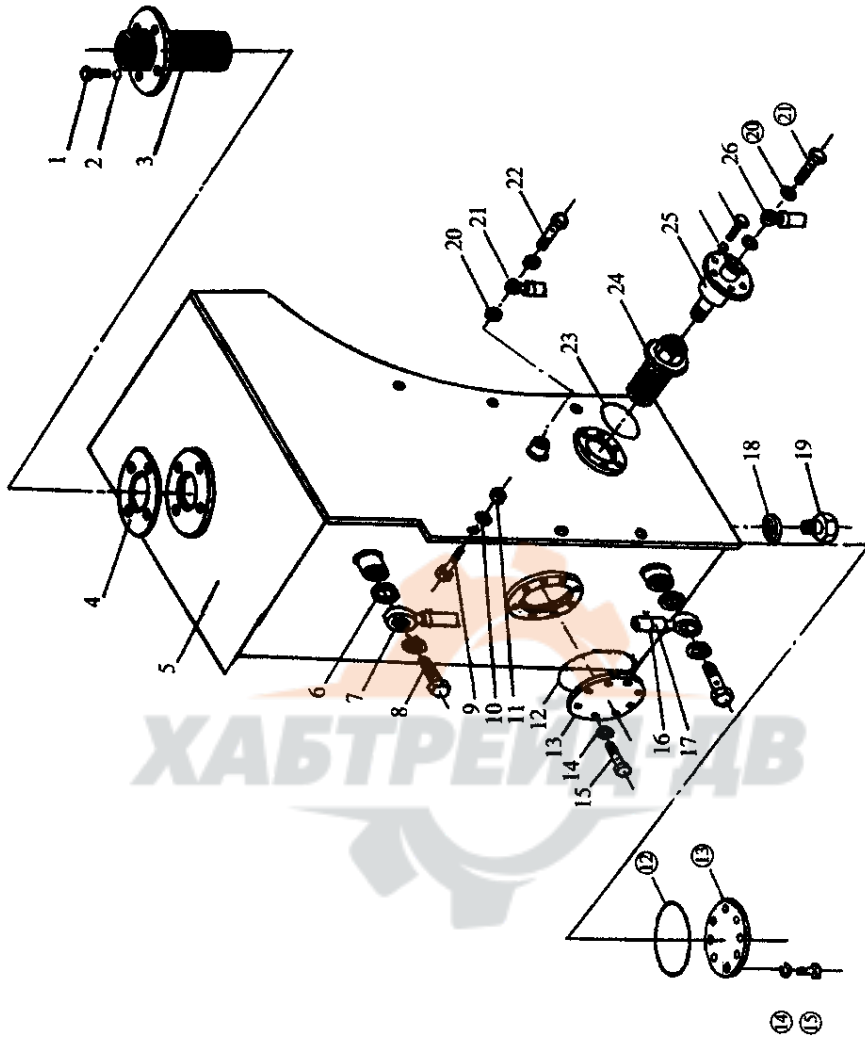

燃油箱总成

FUEL TANK ASSEMBLY

序号 Index No.	件 号 Part No.	名 称 Description		数量 Q'ty
02—1	GB5783-86	螺栓 M8×15	Blot	4
2	GB93-87	垫圈 8	Washer	4
3	11A-80um	加油滤清器	Oil-filling strainer	1
4	ZL30G-01202	垫	Spacer	1
5	ZL30G-01201	燃油箱体	Fuel tank	1
6	JB982-77	组合垫圈 10	Lock washer	4
7	ZL30G-01208	铰接接头体	Fitting	2
8	ZL30G-01207	铰接螺栓	Pipe-fitting bolt	2
9	GB5782-86	螺栓 M16×50	Blot	6
10	GB93-87	垫圈 16	Washer	6
11	GB6170-86	螺母 M16	Nut	6



12	GB1235-76	O 形圈 $\phi 180 \times 5.7$	O-ring	2
13	ZL30G-01211	盖	Cap	2
14	GB93-87	垫圈 10	Washer	31
15	GB5783-86	螺栓 M10 \times 25	Bolt	30
16	ZL30G-01209	卡箍	Clamp	2
17	ZL30G-01210	透明塑料胶管	Plastic hose	1
18	JB982-77	组合垫圈 27	Lock washer	1
19	JB1000-77	螺塞	Screw plug	1
20	JB982-77	组合垫圈 14	Lock washer	4
21	ZL30E-01013B	回油胶管	Oil-return tube	1
22	ZL30G-01205	铰接螺栓	Pipe-fitting bolt	2
23	GB1235-76	O 形圈 $\phi 65 \times 3.1$	O-ring	1
24	Wu25 \times 100-J	滤清器	Oil-filling	1
25	ZL30G-01206	吸油管法兰	Suction pipe flange	1
26	GB3452-83	燃油吸油管	Suction fuel tube	1

第 03 图

油门操纵系统

FIG.03 ACCELERATOR CONTROL SYSTEM

图3 油门操纵系统 Fig3 Accelerator control System

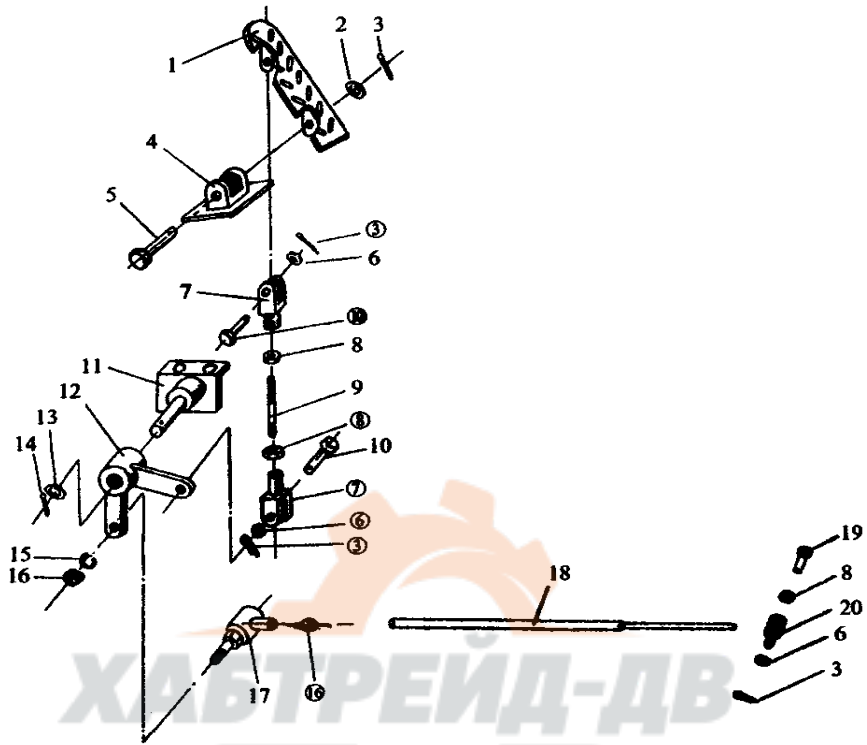

油门操纵系统

ACCELERATOR CONTROL SYSTEM

序号 Index No.	件 号 Part No.	名 称 Description		数量 Q'ty
03—1	ZL30E-01003	油门踏板	Accelerator pedal	1
2	GB95-86	垫圈 8	Washer	1
3	GB91-86	开口销 2×20	Pin	4
4	ZL30E-01008	踏板支架	Bracket	1
5	ZL30E-01007	销轴	Pin	3
6	GB95-86	垫圈 6	Washer	2
7	ZL30E-01005	联接叉	Clevis	3
8	GB6170-86	螺母 M6	Nut	1
9	ZL30E-01006	拉杆	Pull rod	2
10	ZL30E-01004	销轴	Pin	1
11	ZL30E-01001	摇臂支架	Bracket of rocket arm	1
12	ZL30E-01002	摇臂	Rocket arm	1
13	GB95-86	垫圈 12	Washer	1
14	GB91-86	开口销 3×30	Pin	2
15	GB93-87	垫圈 8	Washer	4
16	GB6170-86	螺母 M8	Nut	2
17	ZL30E-01007A	球铰总成	Ball pivot assembly	1
18	ZL30E-01015A	拉杆	Pull rod	1
19	GB5781-86	螺栓 M6×50	Blot	1
20	ZL30E-01033B	联接轴	Connect shaft	1

第04图

变速操纵系统

FIG.04 TRANSMISSION CONTROL SYSTEM

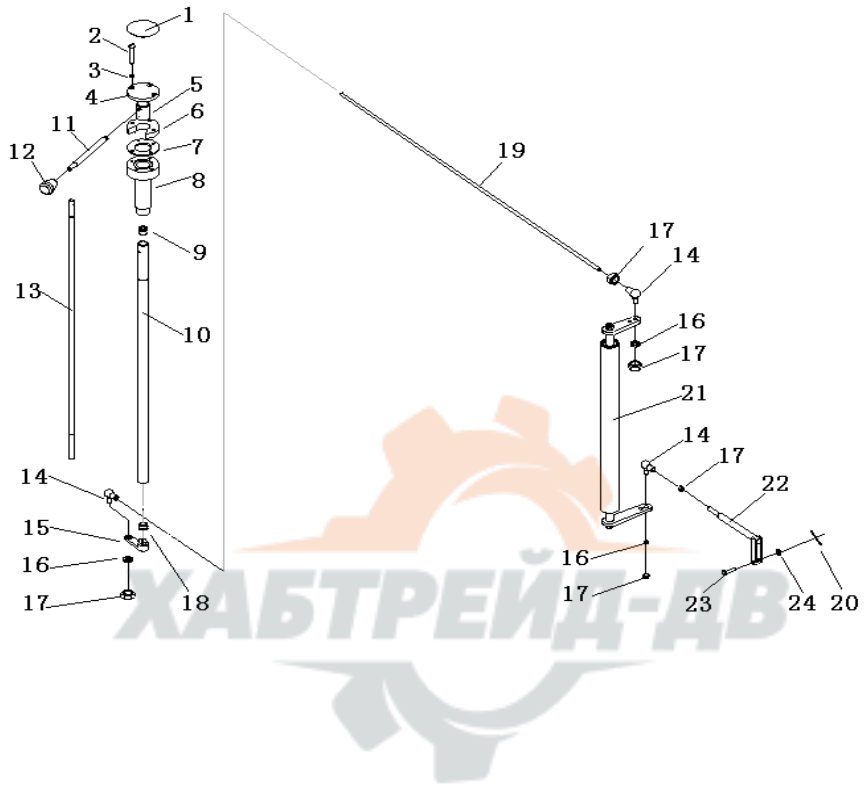

变速操纵系统

TRANSMISSION CONTROL SYSTEM

序号 Index No.	件 号 Part No.	名 称 Description	数量 Q'ty
04—1	ZL30GII-03113	盖 Cover	1
2	GB67-85	螺钉 M5×35 Screws	3
3	GB93-87	垫圈 5 Washer	3
4	ZL30GII-03111	上盖 Superior cover	1
5	ZL30GII-03112	手柄座 Handle block	1
6	ZL30GII-03114	扇形块 Fan-shaped block	1
7	ZL30GII-03115	垫 Mat	1
8	ZL30GII-03116	座 Block	1
9	ZL30GII-03110	衬套 Bushing	1
10	ZL30GII-03107	套管 Pipe covering	1
11	ZL30GII-03104	手柄 Handle	1
12	ZL30GII-03105	手柄套 Handle sleeve	1
13	ZL30GII-03117	操纵杆 Control shank	1
14	SR8-RS	球铰总成 Ball pivot assembly	3
15	ZL30GII-03102	摇臂 Rocket arm	1
16	GB93-87	垫圈 8 Washer	4
17	GB6170-86	螺母 M8 Nut	6
18	ZL30GII-03101	衬套 Bushing	1
19	ZL30GII-03124	丝杆 Thread rod	1
20	GB91-86	开口销 2×25 Pin	1
21	ZL30GII-03122	摇架管 Bracket arm pipe	1
22	ZL30GII-03123	拉杆 Pull rod	1
23	ZL30GII-03103	销轴 Pin	1
24	GB95-87	垫圈 8 Washer	1

第 05 图 变矩器

FIG.05 TORQUE CONVERTER

YJ315X系列液力变矩器零件目录

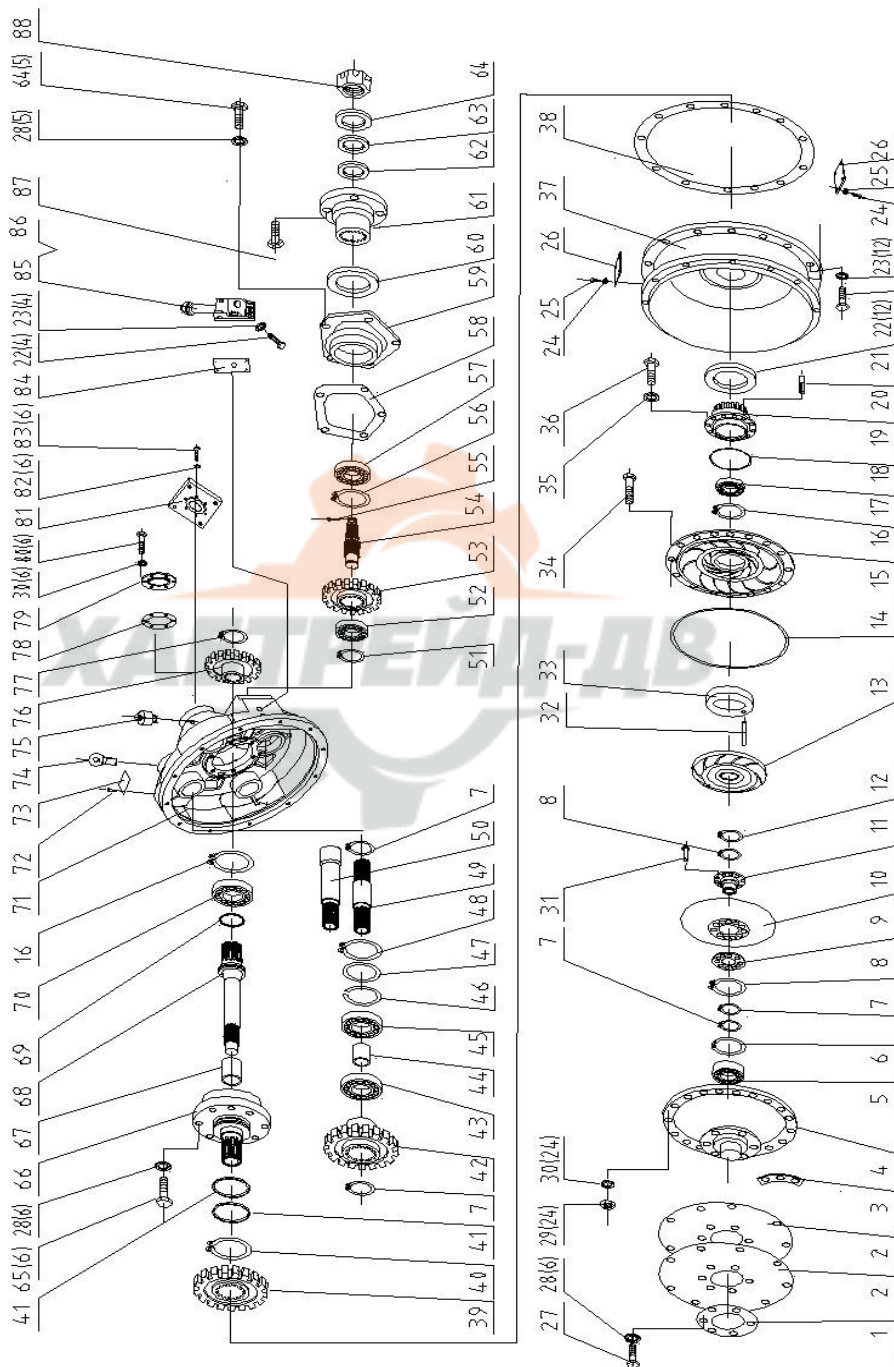

变 矩 器

TORQUE CONVERTER

序号 Index No.	件号 Part No.	名称 Description	数量 Q'ty
05-1	YJ315Y-00018	圆垫板 Gasket	1
2	YJ315Y-00002	弹性板 Elasticity board	1
3	YJ315Y-30000	弹性板总成 Elasticity board assembly	1
4	YJ315X-00002	罩轮 Cover wheel	1
5	GB289-64	滚针轴承 4074106 needle bearing	1
6	04065-05520	挡圈 55 Snap ring	1
7	04064-03015	挡圈 30 Snap ring	5
8	04064-03818	挡圈 38 Snap ring	2
9	ZL30D-11-29	垫板 Gasket	1
10	ZL30D-11-37	涡轮 Runner	1
11	ZL30D-11-28	涡轮座 Runner seat	1
12	04064-06020	挡圈 60 Snap ring	1
13	ZL30D-11-27	导轮 Stator	1
14	GB/3452.1-92	O型圈 $\phi 338 \times 3.55$ O-Ring	1
15	YJ315X-00003	泵轮 Impeller	1
16	GB893.1-86	孔用挡圈 110 Snap ring for vent	2
17	GB276-89	轴承 212 Bearing	1
18	GB1235-76	O型圈 $\phi 130 \times 3.1$ O-Ring	1
19	ZL30D-11-21	泵轮座 Impeller seat	1
20	ZL30D-11-22	定位销 Place pin	4
21	ZL30D-11-54	骨架油封 Skeleton	1
22	01010-51030	螺栓 M10×30 Blot	16
23	01602-21030	垫圈 10 Spring washer	16
24	01010-50610	螺栓 M6×10 Blot	12
25	01602-20619	垫圈 6 Spring washer	12
26	YJ315X-00004	盖 Cap	2
27	01010-51225	螺栓 M12×25 Blot	8
28	01602-21236	垫圈 12 Spring washer	17
29	01508-10806	螺母 M8 Nut	24
30	01602-20825	垫圈 8 Spring washer	24
31	04400-00830	铆钉 8×30 Rivet	1
32	04025-00620	销 6×20 Pin	1
33	ZL30D-11-24	隔环 Separate ring	1
34	01010-50835	螺栓 M8×35 Blot	24
35	01010-50822	螺栓 M8×22 Blot	8
36	GB859-87	轻型弹簧垫圈 8 Spring washer	8
37	YJ315X-00001	飞轮壳中节 Flywheel shell burl	1
38	ZL30D-11-38	垫片 Gasket	1
39	ZL30D-11-20	驱动油泵主动齿轮 rive oil pump initiative gear	1

第 05 图 变矩器

FIG.05 TORQUE CONVERTER

YJ315X系列液力变矩器零件目录

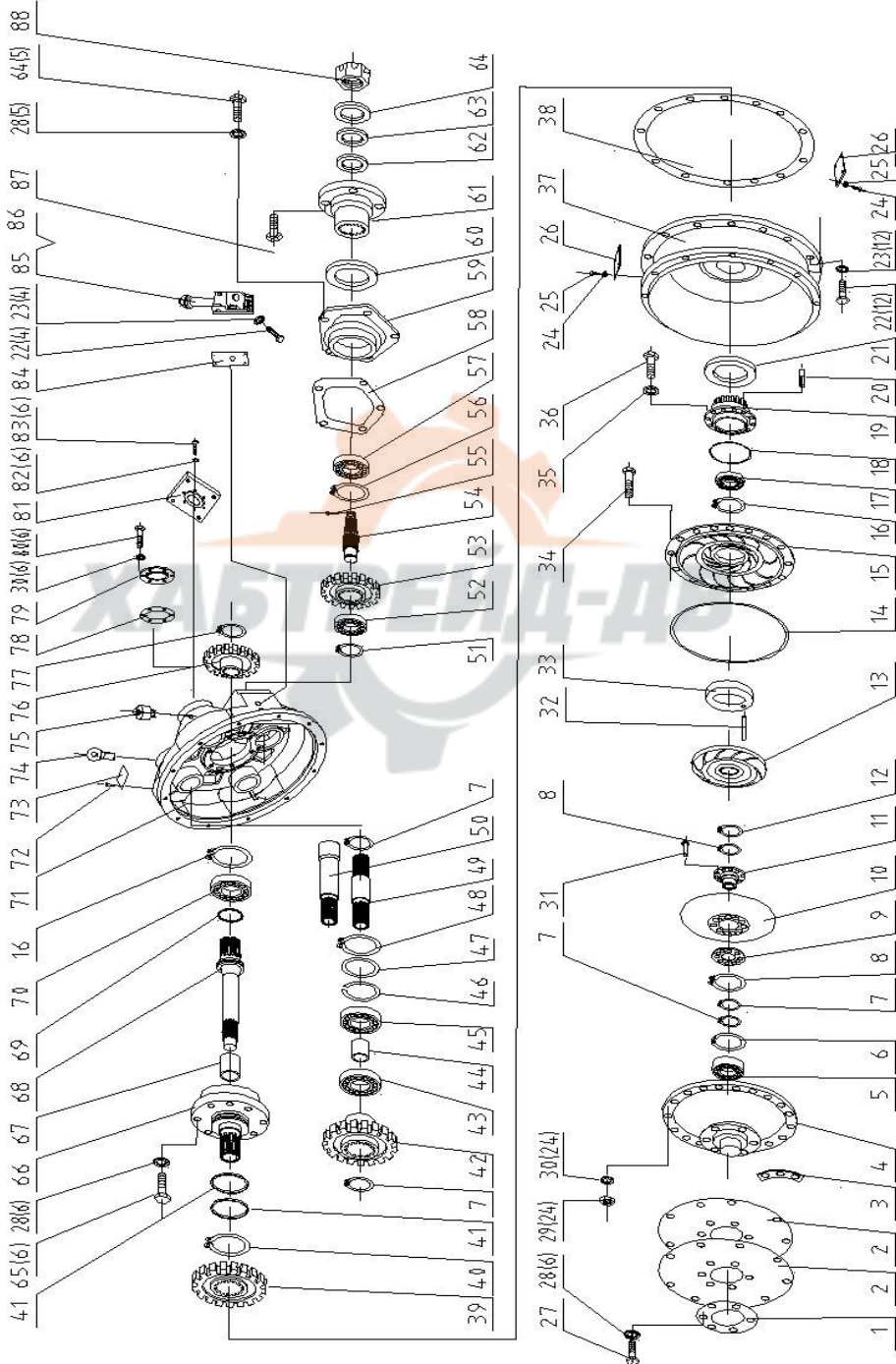

变矩器

TORQUE CONVERTER

序号 Index No.	件号 Part No.	名称 Description	数量 Q'ty
05-41	ZL30D-11-19	密封环 80	2
42	ZL30D-11-39	驱动油泵被动齿轮	3
43	GB276-89	轴承 206	3
44	ZL30D-11-40	套	3
45	GB277-64	轴承 50206	3
46	ZL30D-11-04	止动环	3
47	ZL30D-11-03	垫片	3
48	04065-06825	挡圈 68	3
49	ZL30D-11-02	驱动油泵轴	3
51	04064-03515	挡圈 35	1
52	GB276-89	轴承 307	1
53	ZL30D-11-18	被动齿轮	1
54	ZL30D-11-15	输出轴	1
55	GB91-86	开口销 5×45	1
56	04065-09030	挡圈 90	1
57	GB276-89	轴承 308	1
58	ZL30D-11-07	密封垫	1
59	ZL30D-11-11	油封法兰	1
60	07012-20055	油封 55×78×12	2
61	ZL30D-11-12	输出法兰	1
62	ZL30D-11-13	垫圈	1
63	ZL30D-11-17	密封垫	1
64	ZL30D-11-16	垫圈	1
65	01010-51230	螺栓 M12×30	11
66	ZL30D-11-05	导轮座	1
67	ZL30D-11-10	套	1
68	ZL30D-11-09	主动轴	1
69	ZL30D-11-08	密封环 60	1
70	GB276-89	轴承 310	1
71	ZL30D-11-01	变矩器壳体	1
72	04418-03060	铆钉 3×6	4
73	09607-05080	标牌	1
76	ZL30D-11-06	主动齿轮	1
77	GB/T894-86	挡圈 48	1
84	YJ315X-00009	密封垫	1
85	YJ320-01000Z	减压阀	1
86	ZL30D-11-47	螺塞	1
87	YJ315X-00008	螺栓 M12×40	4

第06图 主减速器总成

FIG.06 CARRIER ASSEMBLY

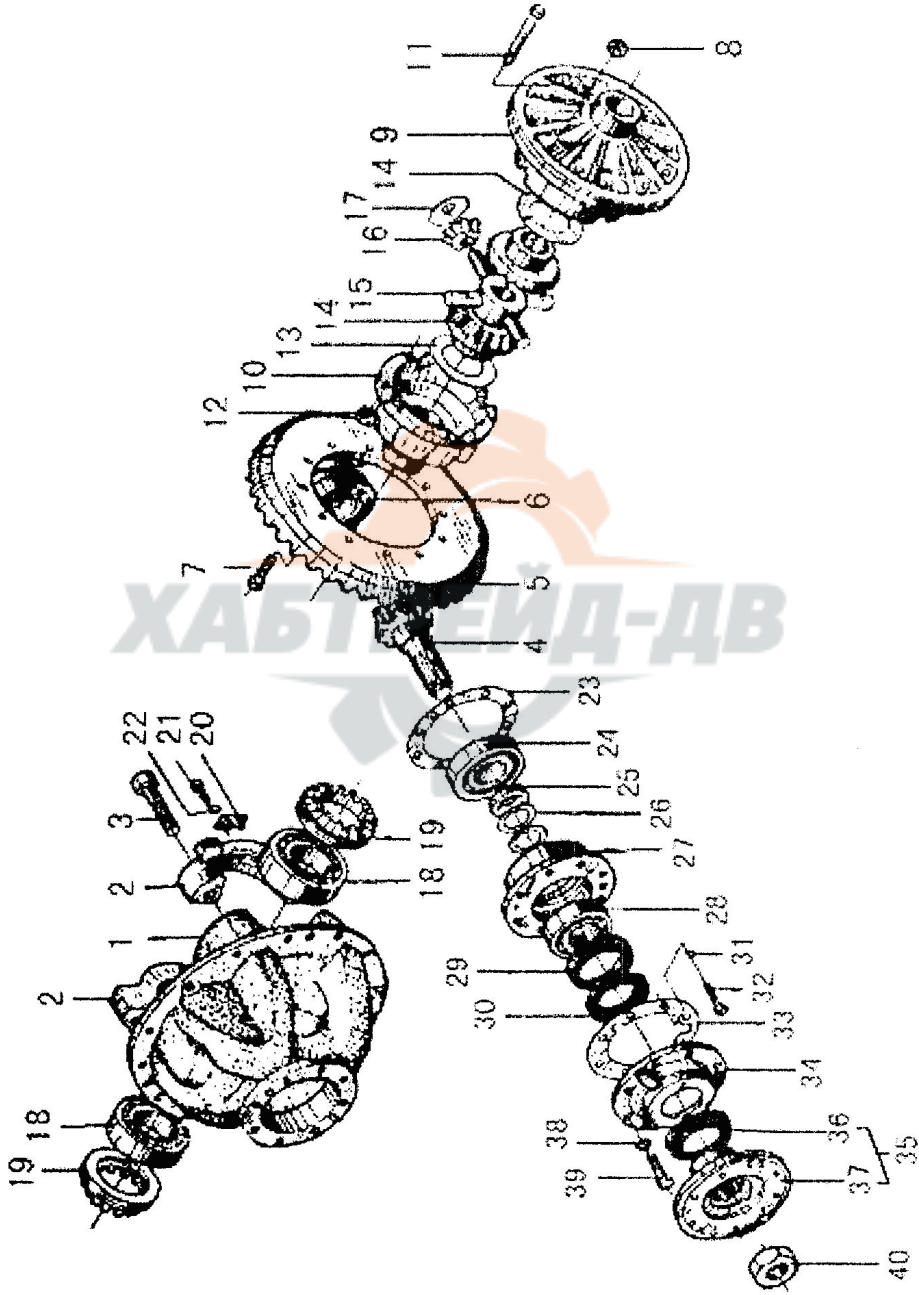

主减速器总成

CARRIER ASSEMBLY

序号 Index No.	件号 Part No.	名称 Description	数量 Q'ty	
06—1	ZL30-Q.3-3	主减速器壳	Carrier	1
2	75200033	轴承盖	Cover	2
3	75502600	螺栓 M22×90	Bolt	4
4	ZL30-QA.3-2	主动螺旋伞齿轮(前桥)	Pinion gear(front axle)	1
5	ZL60-HA.2-2	主动螺旋伞齿轮(后桥)	Pinion gear(rear axle)	1
6	75201829D	大螺伞(前桥)	Ring gear(front axle)	1
7	75201829C	大螺伞(后桥)	Ring gear(rear axle)	1
8	75600311	轴承	Bearing	1
9	75500003	螺栓	Bolt	12
10	GB/T6187-2000	螺母 M14×1.5	Nut	8
11	CZQ320.1.1-4	差速器大半壳	Case half	1
12	CZQ320.1.1-3	差速器小半壳	Case half	1
13	75501980	凸缘螺栓	Bolt	8
14	GB/T6187-2000	螺母 M14×1.5	Nut	8
15	CZQ320.1.1-2	半轴齿轮垫片	Thrust washer	2
16	CZQ320.1.1-1	半轴齿轮	Side gear	2
17	75201607	行星齿轮垫片	Thrust washer	4
18	GB/T297-1994	轴承 30215	Bearing	2
19	ZL30-Q.3-4	差速器螺母	Diff. nut	2
20	75200053A	锁紧片	Lock plate	2
21	GB/T32.1-1998	螺栓 M10×20	Bolt	2
22	GB/T93-1987	垫圈 10	Washer	2
23	404325	调整垫片	Washer	1 组
24	GB/T297-1994	轴承 30311	Bearing	1
25	ZL30-Q.3-1	轴承隔套	Bearing sleeve	1
26	75200036	垫片	Washer	1 组
27	ZL30-Q.3-2	轴承座	Bearing seat	1
28	GB/T297-1994	轴承 30310	Bearing	1
29	ZL30G-05101	接线盖	Operating cover	1
30	GB/T9877.1-1997	油封 FB80×100×10F	Oil seal	1
31	GB/T9877.1-1997	油封 FB80×100×10F	Oil seal	1
32	GB/T93-1987	垫圈 12	Washer	1
33	75500006	螺栓	Bolt	1
34	75200040	衬垫	Washer	1
35	82050401	法兰总成	Flange assembly	1
36	75200046	防尘罩	Dust cover	1
37	82050402	法兰	Flange	1
38	GB/T93-1997	垫圈 14	Washer	7
39	75500005	螺栓	Bolt	7
40	GB/T889.2-2000	螺母 M30×1.5	Nut	1

第07图 轮边总成

FIG.07 WHEEL END ASSEMBLY

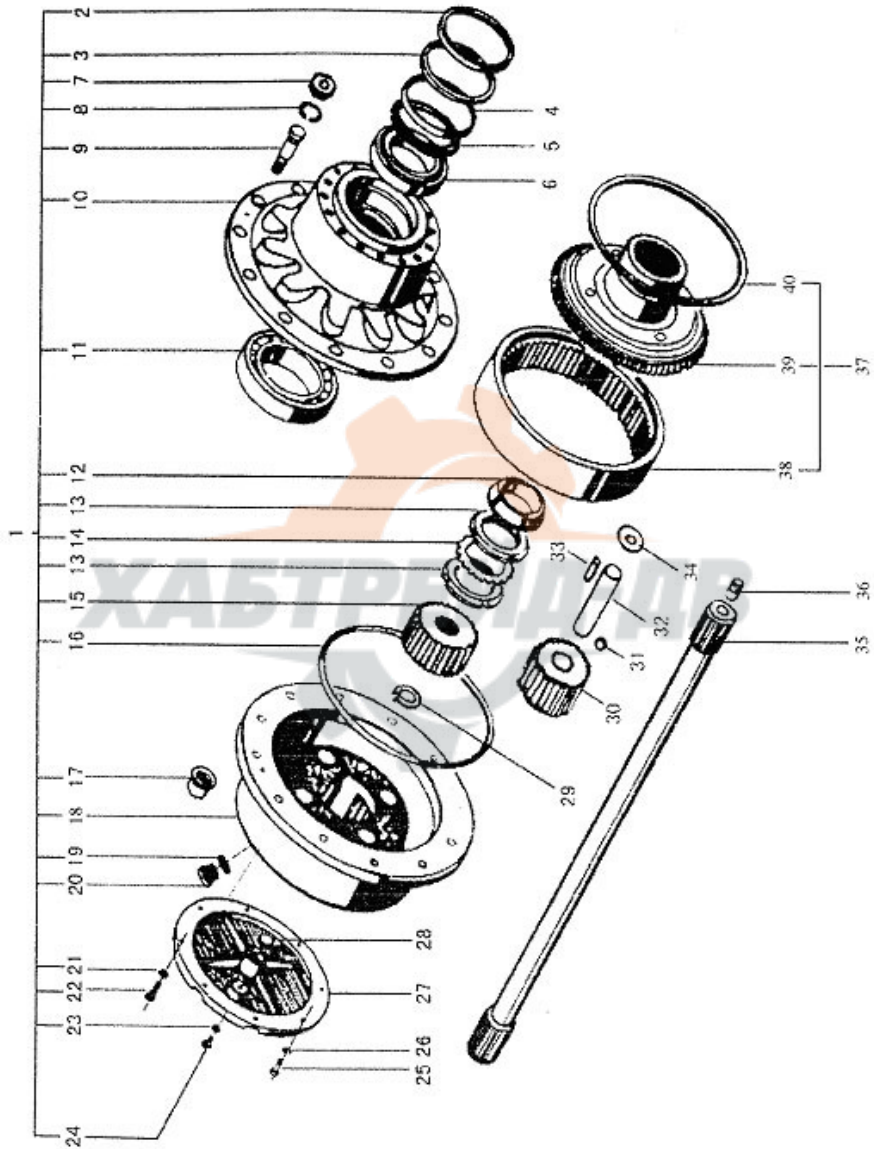

轮边总成

WHEEL END ASSEMBLY

序号 Index No.	件 号 Part No.	名 称 Description		数量 Q'ty
07—1	CZQ320.3	轮边总成	Wheel end assembly	2
2	79500813A	油封座	Oil seal seat	1
3	GB/T9877.1-1997	油封 FB150×180×15-D	Oil seal	1
4	GB/T9877.1-1997	油封 FB150×180×15-D	Oil seal	1
5	79500823	挡油板	Plate	1
6	GB/T297-1994	轴承 32024	Bearing	1
7	GB/T6171-2000	螺母 M20×1.5	Nut	12
8	GB/T93-1987	垫圈 20	Washer	12
9	75502317A	轮辋螺栓	Rim bolt	12
10	83020502	轮辋	Hub	1
11	GB/T297-1994	轴承 32026	Bearing	1
12	76101041	锥套	Sleeve	1
13	75501646	螺母 M85×2	Nut	2
14	GB/T858-1998	止动垫圈 85	Washer	1
15	CZQ320.3-1	太阳轮	Sun gear	1
16	75501707C	密封圈	Seal ring	1
17	ZL30E3-3	轮辋螺母	Rim nut	12
18	CZQ320.3-3	行星轮架	Spider	1
19	JB/T972-1977	组合垫圈 24	Washer	1
20	75500195A	螺塞 M24×1.5	Oil seal plug	1
21	GB/T93-1987	垫圈 10	Washer	1
22	GB/T5786-2000	螺栓 M10×1.25×25	Bolt	1
23	JB/T972-1977	组合垫圈 12	Washer	1
24	75500842	螺塞 M12×1.25	seal plug	1
25	GB/T5786-2000	螺栓 M12×1.25×25	Bolt	5
26	GB/T93-1987	垫圈 12	Washer	5
27	79001544B	盖	Cover	1
28	73520042	限位块	Block	1
29	GB/T894-1-1986	挡圈 42	Ring	1
30	CZQ320.3-2	行星轮	Planet gear	3
31	GB/T308-2002	钢球 3/8"	Steel ball	3
32	CZQ320.3-4	行星轮轴	Planet pin	3
33	GB/T309-2000	滚针 Φ6×50	Roll bearing	63
34	75600456B	挡板	Plate	6
35	CZQ320-2	半轴	Shaft	1
36	77000044	调整支柱	Adjust pin	1
37	CZQ320.3.1	齿圈支承总成	Ring gear carrier assembly	1
38	CZQ320.3-1	齿圈	Ring gear	1
39	CZQ320.3-2	齿圈支承	Ring gear carrier	1
40	76101033A	卡环	Thrust ring	1

第 08 图 主传动轴

FIG.08 MAIN DRIVE SHAFT

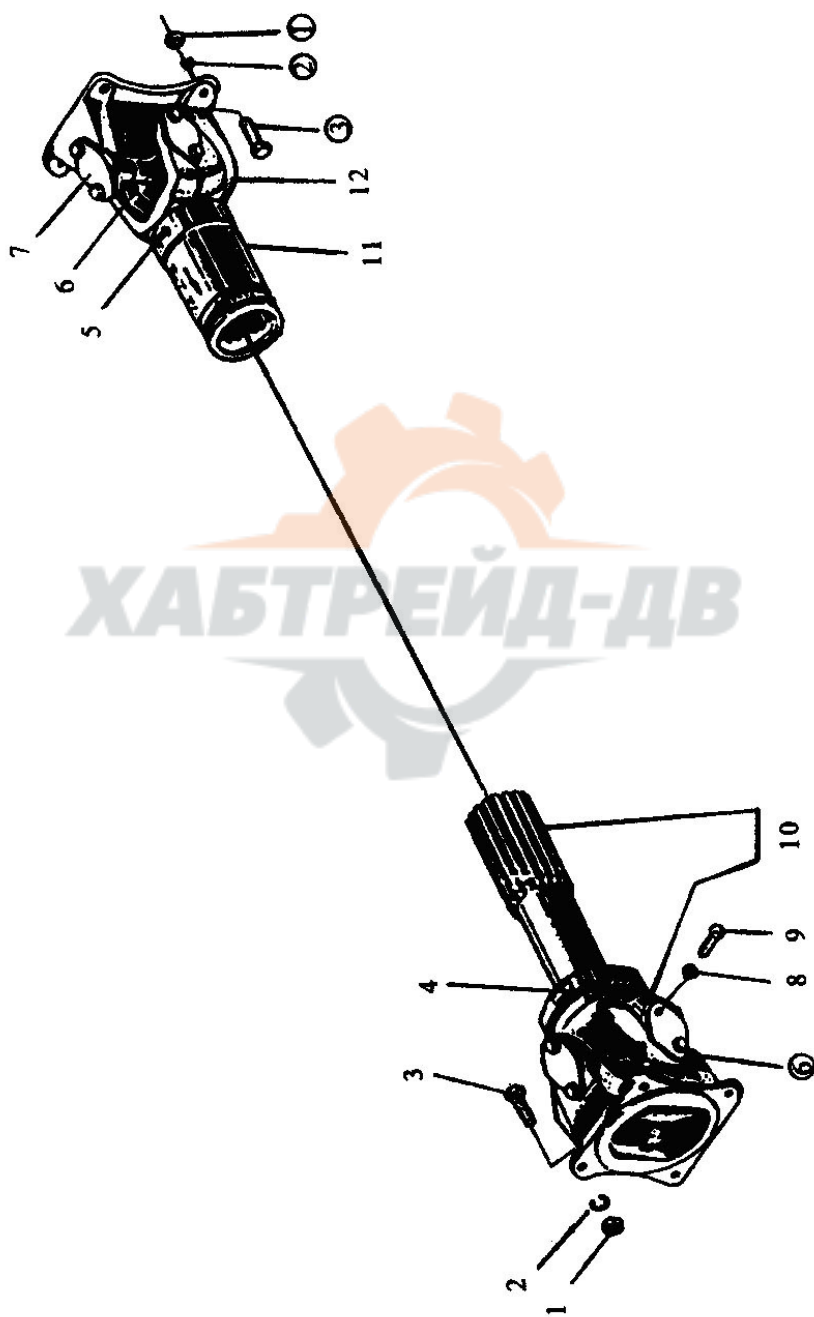

主传动轴

MAIN DRIVE SHAFT

序号 Index No.	件 号 Part No.	名 称 Description	数量 Q'ty
08—1	ZL30C-04003	螺母 Nut	8
2	GB93-87	垫圈 12 Spring washer	8
3	ZL30C-04004	螺栓 Bolt	8
4	30-2203072	平衡片 Balance plate	1
5		油杯 Oil cup	1
6		凸缘叉 Flange fork	2
7		支撑片 Support washer	8
8	GB93-87	垫圈 8 Spring washer	16
9		螺栓 M8×10 Bolt	16
10		万向节及花键轴总成 gimbal & spline shaft assembly	1
11		万向节滑动叉总成 gimbal sleeve fork assembly	1
12		万向节十字头总成 gimbal turning assembly	2



第09图 后传动轴

FIG.09 REAR DRIVE SHAFT

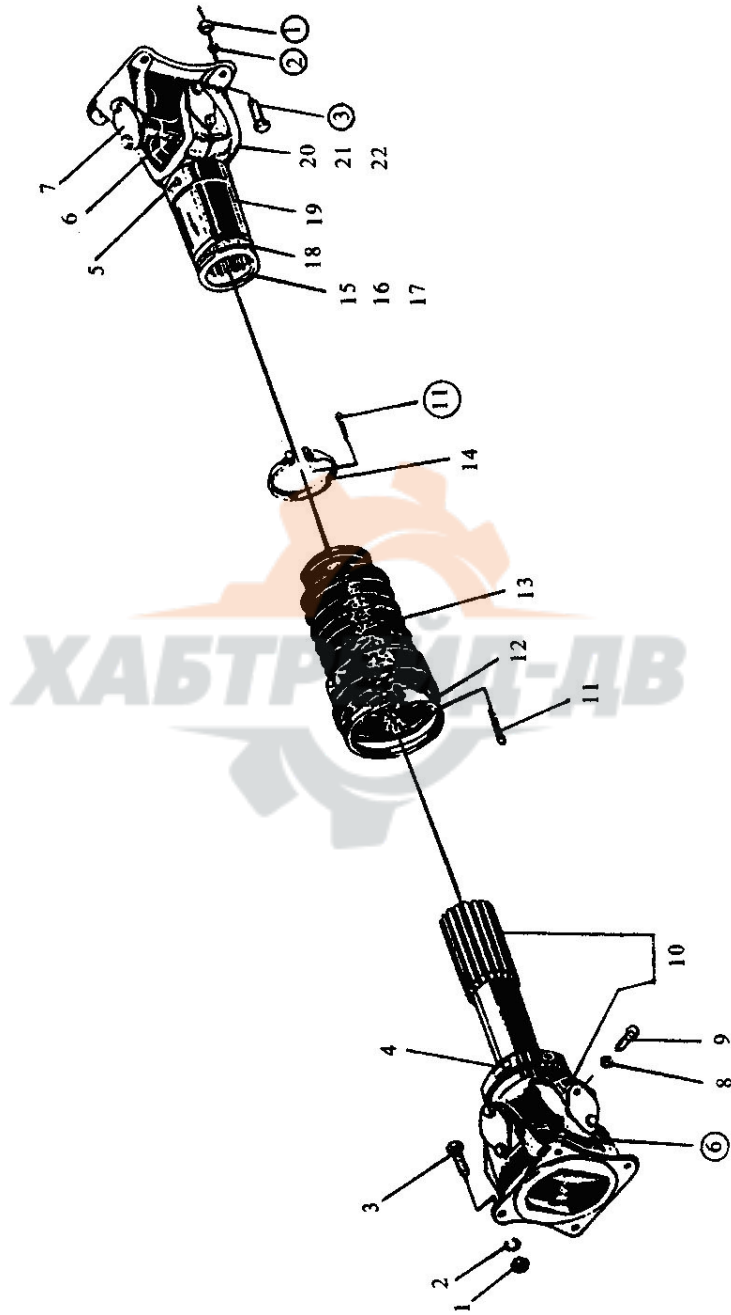

后传动轴

REAR DRIVE SHAFT

序号 Index No.	件 号 Part No.	名 称 Description	数量 Q'ty
09—1	ZL30C-04001	螺母 Nut	8
2	GB93-87	垫圈 12 Spring washer	8
3	ZL30C-04005	螺栓 Bolt	8
4		平衡片 Balance plate	1
5		油杯 Oil cup	1
6	120-2201023	凸缘叉 Flange fork	2
7	120-2201050B	支撑片 Support washer	8
8	GB93-87	垫圈 8 Spring washer	16
9		螺栓 M8×10 Bolt	16
10		万向节及花键轴总成 gimbal & spline shaft assembly	1
11		开口销 Pin	2
12		卡箍 Clamp	1
13	120-2201066	防护罩 Dust cap	1
14		卡箍 Clamp	1
15	120-2201065	盖 Cap	1
16	120-2201088	填密圈 Washer	1
17	120-2201089	垫圈 Washer	1
18		卡箍 Clamp	2
19	120-2201047	万向节滑动叉总成 gimbal sleeve fork assembly	1
20	120-2201026	万向节十字头总成 gimbal turning assembly	2
21	120-2201044	万向节滚针轴承总成 gimbal needle bearing assembly	8
22	120-2201051B	锁片 Lock plate	8

第 10 图

转向液压系统

FIG.10 STEERING HYDRAULIC SYSTEM

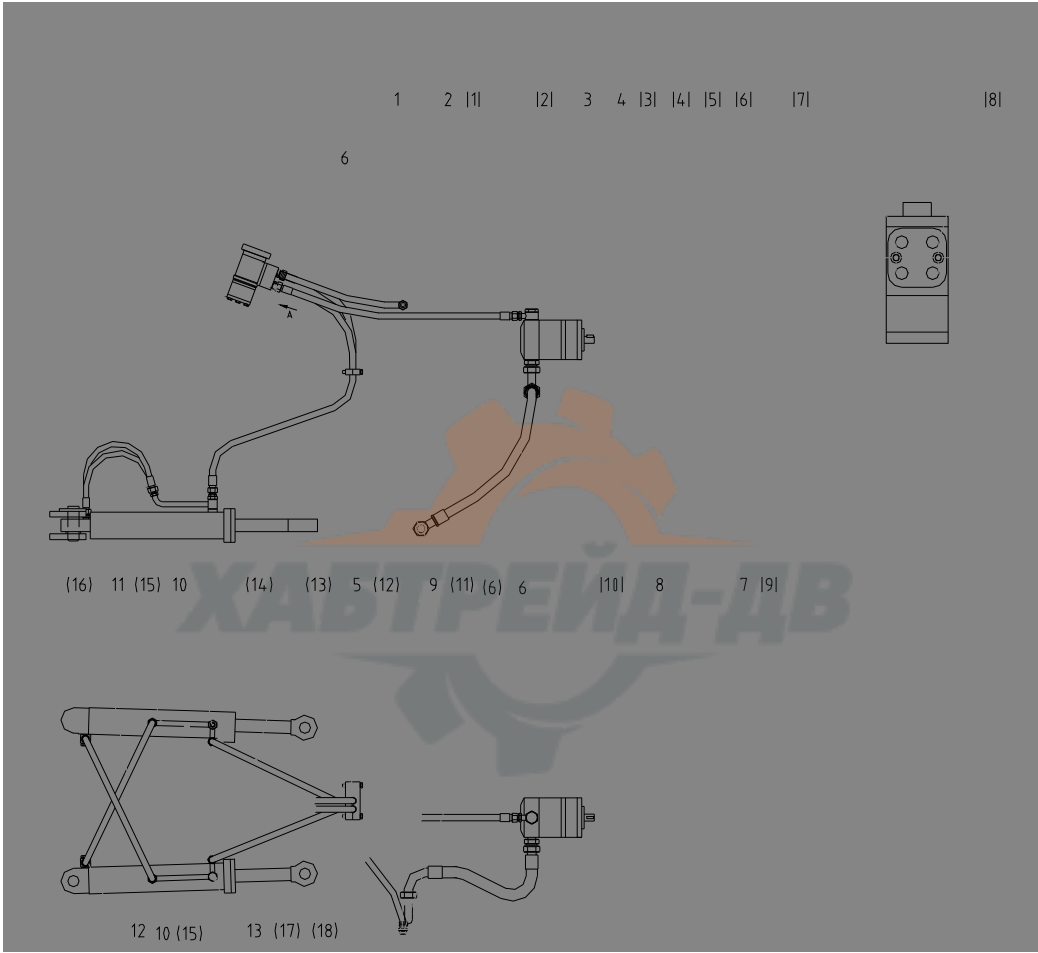

转向液压系统

STEERING HYDRAULIC SYSTEM

序号 No.	件 号 Part No.	名 称 Description		数量 Q'ty
10—1	DG930B-05100	方向机总成	Steering gear assembly	1
2	DG930B-05001	回油胶管	Oil return hose	1
3	ZL30E-05002	接头总成	Fitting assembly	1
4	ZL30E-05003	铰接螺栓	Articulation blot	1
5	DG930B-05004	接头体	Fitting	3
6	DG930B-05005	接头体	Fitting	2
7	ZL30E-05006	接头体	Fitting	1
8	ZL30E-05007	接头总成	Fitting assembly	1
9	ZL30E-05008	接头体	Fitting	1
10	DG930A-05009	管卡	Clamp for tube	2
11	ZL30E-05010	铰接螺栓	Articulation blot	3
12	ZL30E-05011	钢管总成	Steel tube assembly	2
13	ZL30E-05012	接头总成	Fitting assembly	2
(1)		双钢丝卡箍(26~30)	Clamp	4
(2)	JF100-81	高压胶管 13	Hose fitting	1
(3)	JB982-77	组合垫圈 27	Lock washer	2
(4)	CB-FE40FL	齿轮泵	Gear pump	1
(5)	GB5783-86	螺栓 M10×30	Bolt	2
(6)	GB93-87	垫圈 10	Spring washer	4
(7)	BZZ-400	转向器	Redirector assembly	1
(8)	FK-10/16	组合阀块	Combination valve block	1
(9)	JB982-77	组合垫圈 33	Lock washer	1
(10)	JF100-81	高压胶管 25	Hose fitting	1
(11)	GB5780-86	螺栓 M10×65	Bolt	2
(12)	JB982-77	组合垫圈 20	Lock washer	5
(13)	JF100-81	高压胶管 13	Hose fitting	2
(14)	HSGF×80/45BE-EG	液压缸	Steering cylinder	2
(15)	JB982-77	组合垫圈 18	Lock washer	8
(16)	JF100-81	高压胶管 13	Hose fitting	2
(17)	JB982-77	组合垫圈 14	Lock washer	1
(18)	JB1000-77	螺塞 M14×1.5	Plug	1

第 11 图 中间轴承座

FIG.11 INTERMEDIATE BEARING CASE

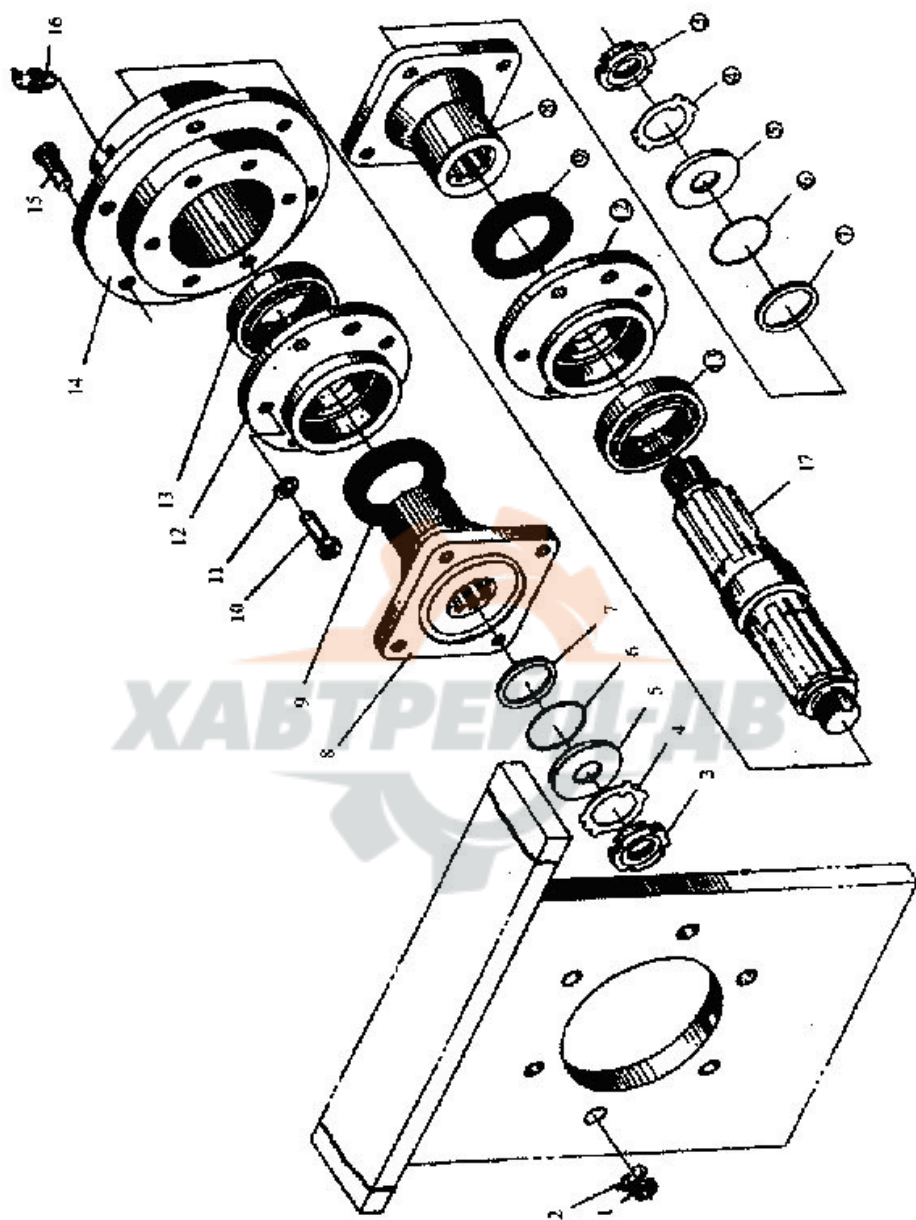

中间轴承座

INTERMEDIATE BEARING CASE

序号 Index No.	件号 Part No.	名称 Description	数量 Q'ty
11—1	GB6170-86	螺母 M12 Nut	6
2	01643-31232	垫圈 12 Spring washer	6
3	GB812-67	圆螺母 M27×1.5 Round nut	2
4	GB858-88	垫圈 27 Lock washer	2
5	ZL30C-04301	垫圈 Washer	2
6	ZL30C-04308	O 型密封圈 O-ring	2
7	ZL30C-04309	纸垫 Gasket	2
8	ZL30C-04305	凸缘 Plange	2
9	HG4-692-67	油封 SG60×80×12 Oil seal	2
10	GB5783-86	螺栓 M10×35 Bolt	12
11	GB93-87	垫圈 10 Spring washer	12
12	ZL30C-04303	轴承端盖 Bearing cover	2
13	GB/T272-94	轴承 7210C/P6 Bearing	2
14	ZL30C-04304	轴承座 Bearing seat	1
15	01010-51255	螺栓 M12×55 Bolt	6
16	GB1153-79	油杯 M10×1 Oil cup	1
17	ZL30C-04302	轴 Shaft	1

第 12 图 方向机总成

FIG.12 STEERING GEAR ASSEMBLY

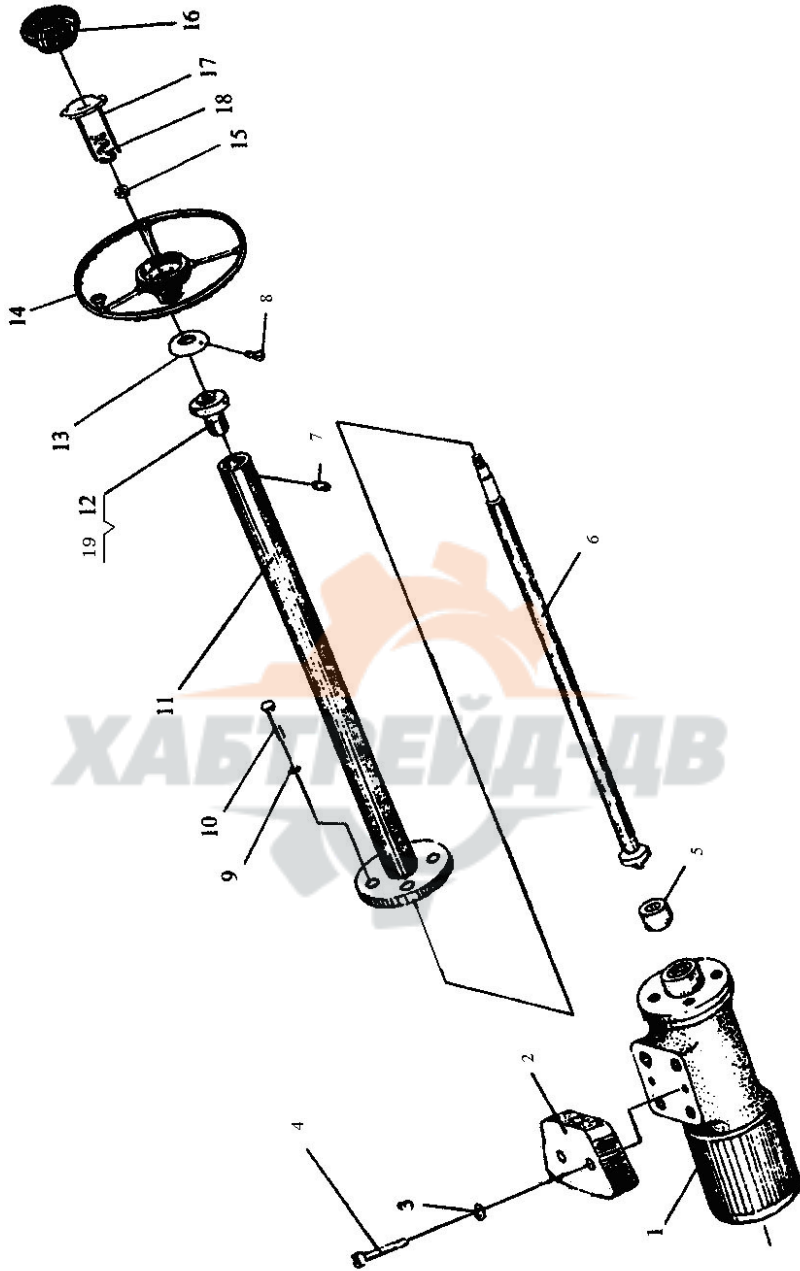

方向机总成

STEERING GEAR ASSEMBLY

序号 Index No.	件 号 Part No.	名 称 Description	数量 Q'ty
12—1	BZZ-400	转向阀总成 Steering gear assembly	1
2	FK-10/16	阀块 Valve block	1
3	GB93-87	垫圈 12 Washer	2
4	GB70-85	螺钉 Screw	2
5		联接块 Coupling block	1
6	ZL30G-05103	转向轴 Steering shaft	1
7	GB71-85	螺钉 M8×10 Screw	1
8	GB67-85	螺钉 M5×8 Screw	2
9	GB93-87	垫圈 10 Washer	4
10	GB70-85	螺栓 M10×25 Bolt	4
11	ZL30G-05104	转向轴套 Steering column	1
12	ZL30G-05102	支承套 Sleeve	1
13	ZL30G-05101	接线盖 Operating cover	1
14		方向盘总成 Steering wheel assembly	1
15	GB6173-86	螺母 M16×1.5 Nut	1
16		喇叭按钮盖 Cover of horn button	1
17		搭铁盘 Grounding disk	1
18		弹簧 Spring	1
19	GB276-89	轴承 1000804 Bearing	1

第 13 图 转向器

FIG.13 STEERING GEAR

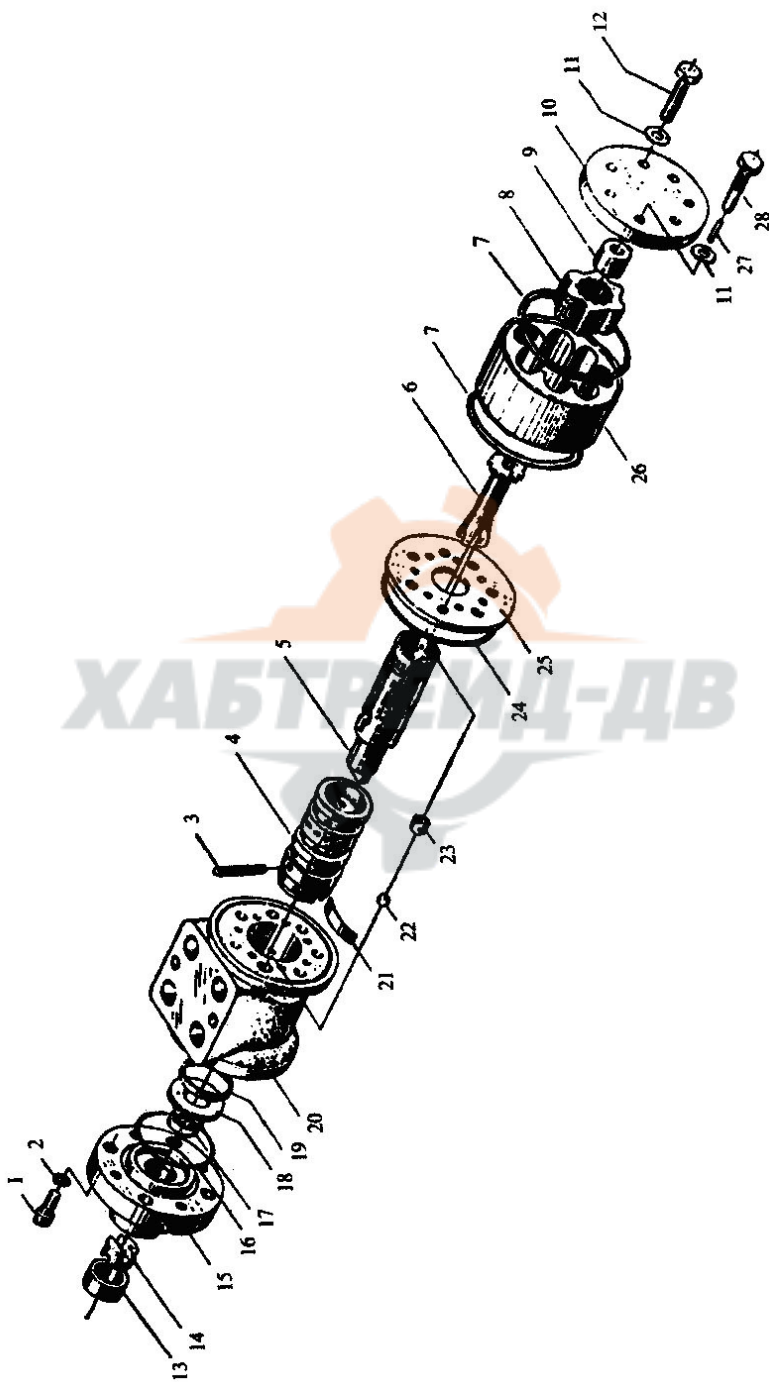

转向器

STEERING GEAR

序号 Index No.	件 号 Part No.	名 称 Description	数量 Q'ty
13—1		螺栓 Bolt	4
2		垫圈 Spring washer	4
3		拔销 Cotter pin	1
4		阀套 Valve sleeve	1
5		阀芯 Valve core	1
6		联动轴 Shaft	1
7		O型圈 95×1.9 O-Ring	2
8		转子 Rotor	1
9		限位柱 Locating stud	1
10		后盖 Rear cover	1
11		铜垫圈 Copper washer	7
12		螺栓 Bolt	6
13		套 Sleeve	1
14		联接块 Connecting block	1
15		前盖 Front cover	1
16		O型圈 60×3.1 O-Ring	1
17		O型圈 20×2.4 O-Ring	1
18		轴承 Bearing	1
19		挡圈 Retaining ring	1
20		阀体 Valve body	1
21		弹簧片 Spring pieces	6
22		钢球 Steel ball	1
23		螺套 Screw sleeve	1
24		O型圈 90×3.1 O-Ring	1
25		隔盘 Separating plate	1
26		定子 Stator sleeve	1
27		限位销 Locating pin	1
28		限位螺栓 Locating bolt	1

第 14 图 工作液压系统

FIG.14 WORK DEVICE HYDRAULIC SYSTEM

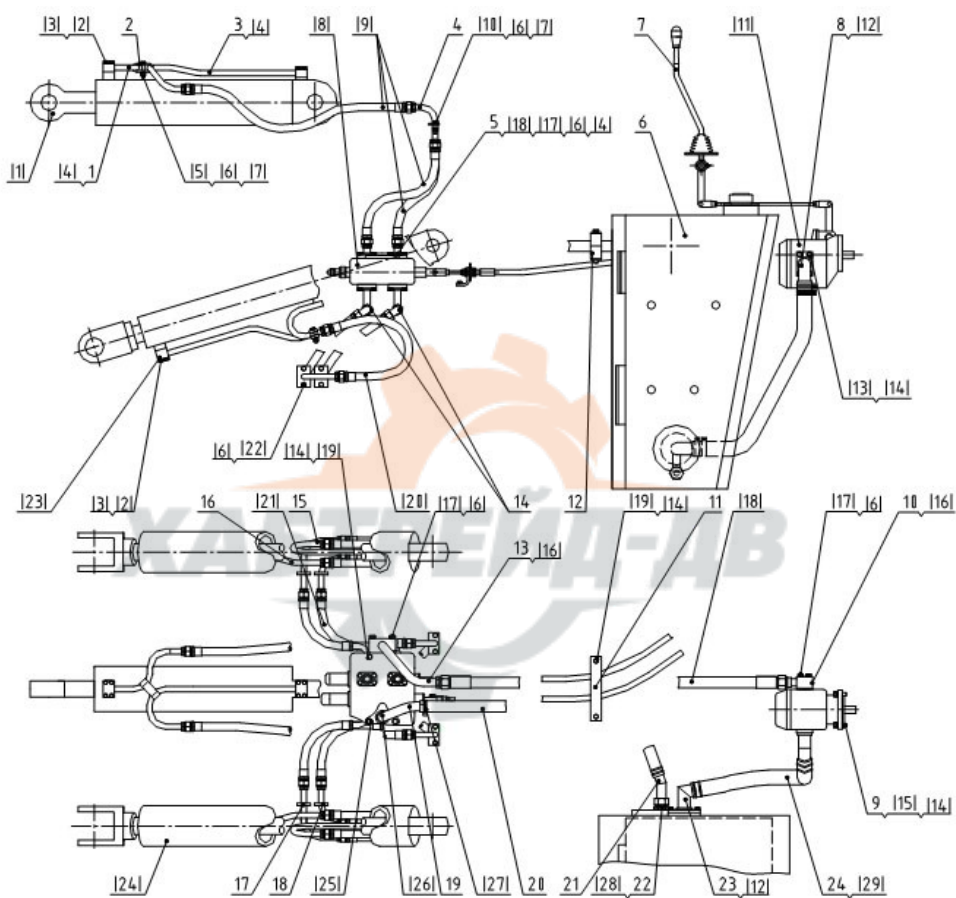

工作液压系统

WORK DEVICE HYDRAULIC SYSTEM

序号 Index No.	件 号 Part No.	名 称 Description	数量 Q'ty
14—1	ZL30E-06001	钢管总成	1
2	ZL30E-06002	管卡	6
3	ZL30E-06003	钢管总成	1
4	ZL30E-06005	钢管总成	2
5	ZL30E-06004	接头总成	1
6	DG930A-06200	液压油箱	1
7	ZL30GII-06100	工作液压操纵系统	1
8	ZL30E-06011	接头总成	1
9	ZL30E-06023	双头螺柱	4
10	ZL30E-06013	接头总成	1
11	ZL30E-06006	管卡	1
12	ZL30E-06006A	管卡	1
13	ZL30E-06019	钢管总成	1
14	ZL30E-06001A	接头总成	2
15	ZL30E-06021	钢管总成	2
16	ZL30E-06022	钢管总成	2
17	ZL30E-06002A	钢管总成	2
18	ZL30E-06003A	钢管总成	2
19	ZL30E-06018	钢管总成	1
20	ZL30E-06017	高压胶管	1
21	ZL30E-06016	接头总成	1
22	ZL30E-06015	接头体	1
23	ZL30GII-06025A	钢管总成	1
24	ZL30GII-06009	吸油胶管	1

第 14 图

工作液压系统

FIG.14 WORK DEVICE HYDRAULIC SYSTEM

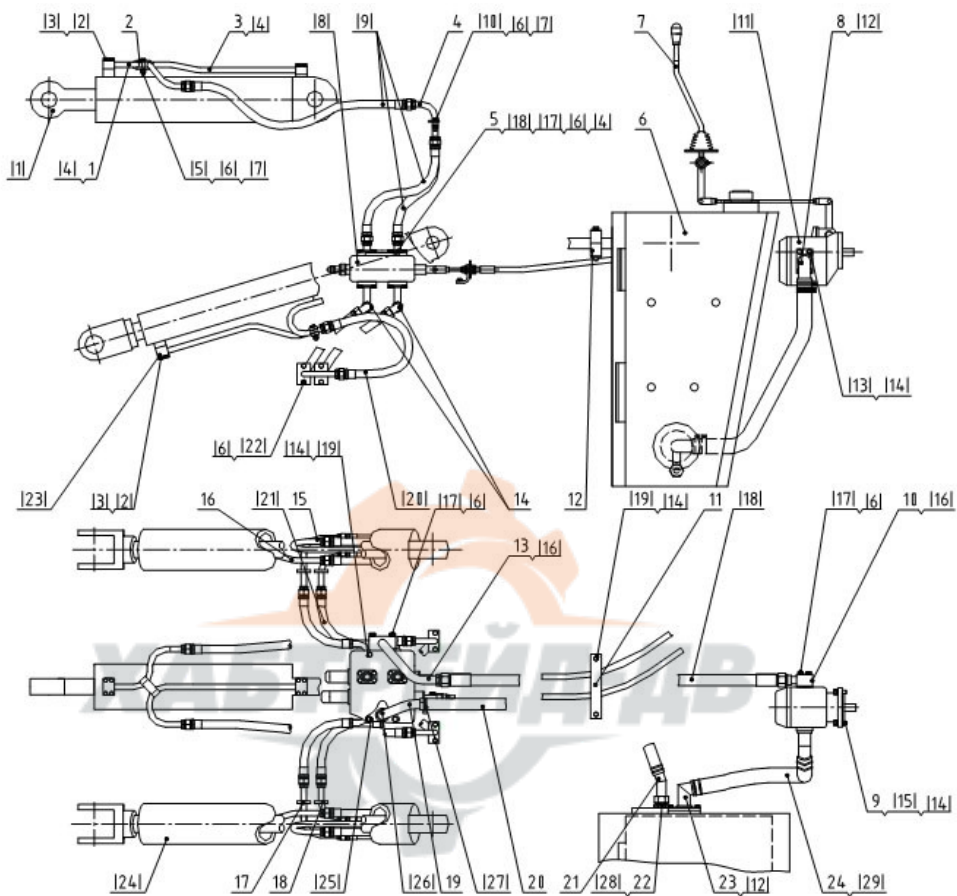

工作液压系统

WORK DEVICE HYDRAULIC SYSTEM

序号 Index No.	件 号 Part No.	名 称 Description		数量 Q'ty
14— (1)	HSGF×140/80B-E-EG	翻斗油缸	Steering bucket cylinder	1
(2)	GB5783-86	螺栓 M8×45	Bolt	24
(3)	GB93-87	垫圈 8	Spring washer 8	24
(4)	GB3452.1-1992	O 形圈 28×3.55	O-ring	6
(5)	GB5781-86	螺栓 M10×55	Bolt	3
(6)	GB93-87	垫圈 10	Spring washer	46
(7)	GB6170-86	螺母 M10	Nut	7
(8)	DF25-2C	多路阀	Distribution valve	1
(9)	JF100-81	高压胶管 19	Hose fitting	4
(10)	GB5783-86	螺栓 M10×30	Bolt	20
(11)	CBGj2100、CBGq2100	齿轮泵	Tandem gear pump	1
(12)	GB3452.1-1992	O 形圈 42.5×3.55	O-ring	2
(13)	GB5781-86	螺栓 M12×35	Bolt	4
(14)	GB93-87	垫圈 12	Spring washer	14
(15)	GB6170-86	螺母 M12	Nut	8
(16)	GB3452.1-1992	O 形圈 φ37.5×3.55	O-ring	2
(17)	GB5783-86	螺栓 M10×60	Bolt	8
(18)	JF100-81	高压胶管 25	Hose fitting	1
(19)	GB5780-86	螺栓 M12×120	Bolt	4
(20)	JF100-81	高压胶管 19	Hose fitting	4
(21)	JF100-81	高压胶管 19	Hose fitting	4
(22)	GB5781-86	螺栓 M10×25	Bolt	15
(23)	GB3452.1-1992	O 形圈 22.4×3.55	O-ring	4
(24)	HSGF×110/63A-E-EG	举升油缸	Lifting cylinder	2
(25)	GB5780-86	螺栓 M12×140	Bolt	2
(26)	GB1235-76	O 形圈 φ50×3.1	O-ring	1
(27)		双钢丝卡箍(43-48)	Clamp	4
(28)	GB982-77	组合垫 42	Lock washer	1
(29)		双钢丝卡箍(57-62)	Clamp	2

第 15 图 液压油箱总成

FIG.15 HYDRAULIC TANK ASSEMBLY

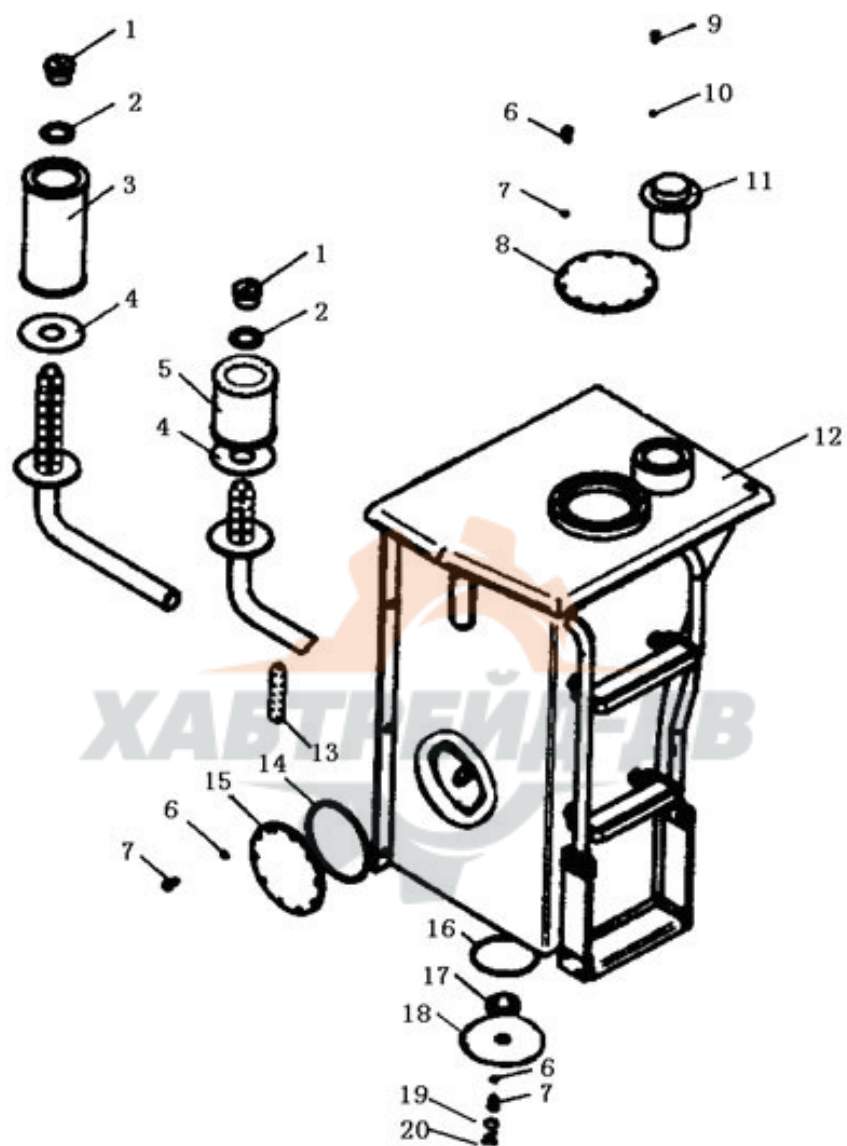

液压油箱总成

HYDRAULIC TANK ASSEMBLY

序号 Index No.	件 号 Part No.	名 称 Description	数量 Q'ty
15—1	ZL30G-06202	螺帽 Screw hat	2
2	ZL30G-06211	垫 Washer	2
3	ZL30G-06204	滤清器 Oil-filling	1
4	ZL30G-06212	垫 Washer	2
5	ZL30G-06203	滤清器 Oil-filling	1
6	GB5781-86	螺栓 M10×25 Blot	28
7	GB93-87	垫圈 10 Washer	28
8	ZL30G-06205	盖 Cap of oil fuer	1
9	GB5781-86	螺栓 M8×15 Blot	4
10	GB93-87	垫圈 8 Washer	4
11	11A-80um	加油滤清器 Oil-filling strainer	1
12	ZL30G-06201	液压油箱体 Fuel tank	1
13	YWZ-127	液位计 Level gauge	1
14	GB1235-76	O 形圈 φ180×5.7 O-ring	1
15	ZL30G-06205	盖 Cap of oil fuer	1
16	GB1235-76	O 形圈 φ140×3.1 O-ring	2
17	ZL30G-06206	磁铁 Magnet	1
18	ZL30G-06207	盘 Disk	1
19	JB982-77	组合垫圈 27 Lock washer	1
20	JB1000-77	螺塞 M27×2 Plug	1

第 16 图 分配阀

FIG.16 DISTRIBUTOR VALVE

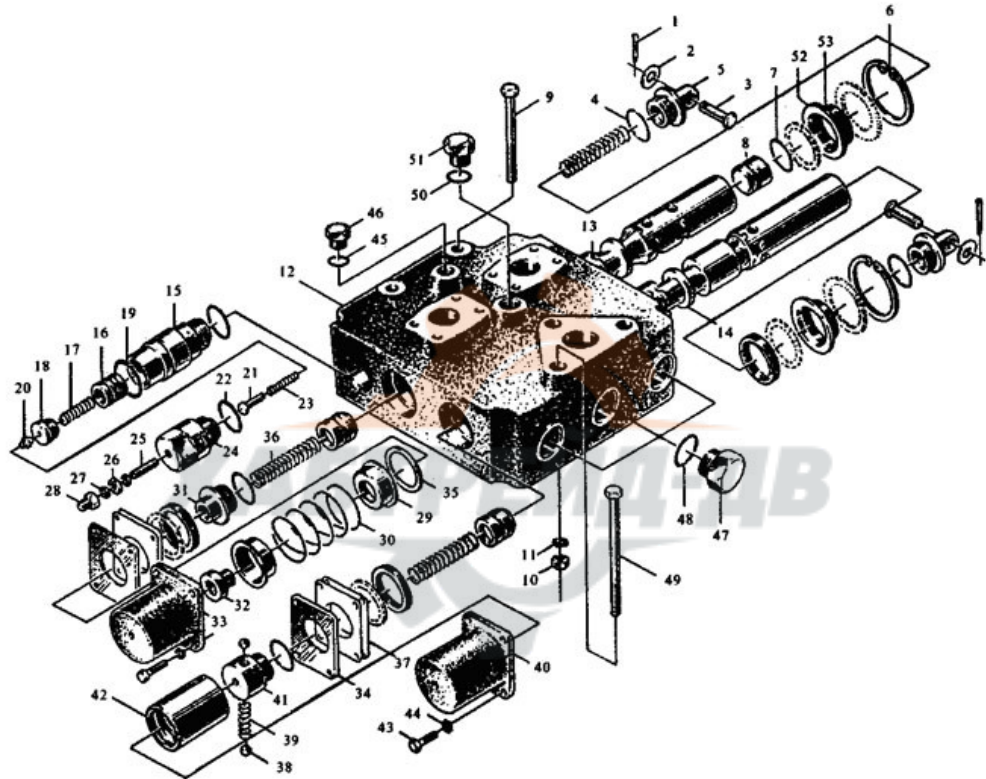

分配阀

DISTRIBUTOR VALVE

序号 Index No.	件号 Part No.	名称 Description	数量 Q'ty	
16—1	GB91-86	销 4×20	Pin	2
2	GB97.1-86	垫圈 12	Washer	2
3	FPF32-1	销	Pin	2
4	GB1235-76	O 型密封圈 3.5×3.1	O-ring	4
5	FPF32-2	弹簧座	Spring seat	2
6	GB893.1-86	挡圈 65	Snap ring	2
7	GB3452.1-82	O 型密封圈 40×3.55	O-ring	4
8	FPF32-4	单向阀	Check valve	3
9	GB5782-86	螺栓 M12×120	Bolt	2
10	GB6170-86	螺母	Nut	4
11	GB93-87	垫圈 12	Washer	4
12	FPF32-5	阀体	Valve body	1
13	FPF32-6	转斗滑阀	Tilt spool	1
14	FPF32-7	动臂滑阀	Lift spool	1
15	FPF32.1-11	主阀套	Sleeve	1
16	FPF32.1-10	主阀芯	Main spool	1
17	FPF32.1-9	主阀弹簧	Main spool spring	1
18	FPF32.1-8	阀座	Valve seat	1
19	GB3452.1-82	O 型密封圈 37.5×3.55	O-ring	1
20	FPF32.1-7	导阀	Relief poppet	1
21	FPF32.1-6	弹簧座	Spring seat	1
22	GB3452.1-82	O 型密封圈 30×2.65	O-ring	2
23	FPF32.1-5	弹簧	Spring	1
24	FPF32.1-4	导阀体	Relief poppet body	1
25	FPF32.1-3	调压丝杆	Adjusting screw	1
26	GB6173-86	螺母 M10×1	Nut	1
27	FPF32.1-2	垫片	Gasket	2
28	FPF32.1-1	锁紧螺母	Lock not	1
29	FPF32-8	弹簧压座	Spring retainer	2
30	FPF32-9	复位弹簧	Back spring	1
31	FPF32-10	弹簧座	Spring seat	1
32	FPF32-11	座	Seat	1
33	FPF32-12	转斗回位套	Tilt return sleeve	1
34	FPF32-15	挡板	Pad	2
35	FPF32-14	垫圈	Washer	1
36	FPF32-13	单向阀弹簧	Check valve spring	3
37		垫	Washer	4
38	GB308-77	钢球 Φ11	Steel ball	2
39	FPF32-16	弹簧	Spring	1
40	FPF32-17	弹簧回位套	Lift return sleeve	1

第 16 图 分配阀

FIG.16 DISTRIBUTOR VALVE

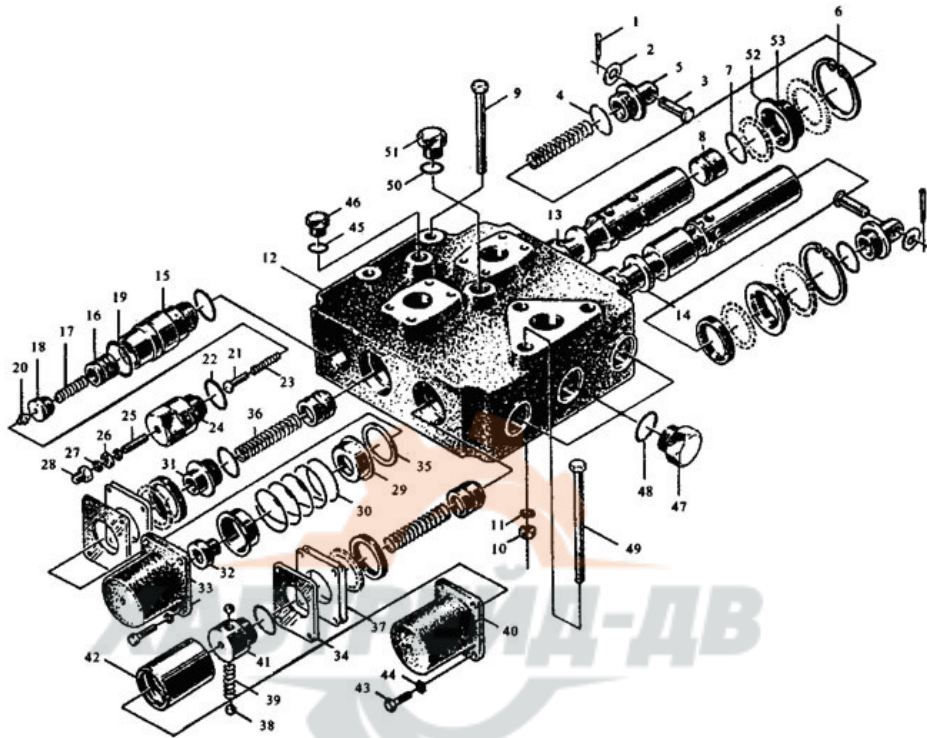

分配阀

DISTRIBUTOR VALVE

序号 Index No.	件 号 Part No.	名 称 Description	数量 Q'ty
16—41	FPF32-18	弹簧座 Spring seat	1
42	FPF32-19	定位套 Sleeve	1
43	GB5782-86	螺栓 M8×25 Bolt	8
44	GB93-87	垫圈 8 Washer	8
45	GB1235-76	O 型密封圈 32×3.1 O-ring	3
46	FPF32-20	螺塞 Screw	1
47	FPF32-21	螺塞 Screw	3
48	GB1235-76	O 型密封圈 32×3.1 O-ring	3
49	FPF32-23	螺栓 M12×140 Bolt	2
50	GB1235-76	O 型密封圈 22×2.4 O-ring	1
51	FPF32-22	螺塞 Screw	1
52	FPF32-3	套 Sleeve	2
53	Q/ZB336-77	防尘圈 40 Dust ring	2

第 17 图 大小腔双作用安全阀

FIG.17 DUALACTION SAFELY VALVE

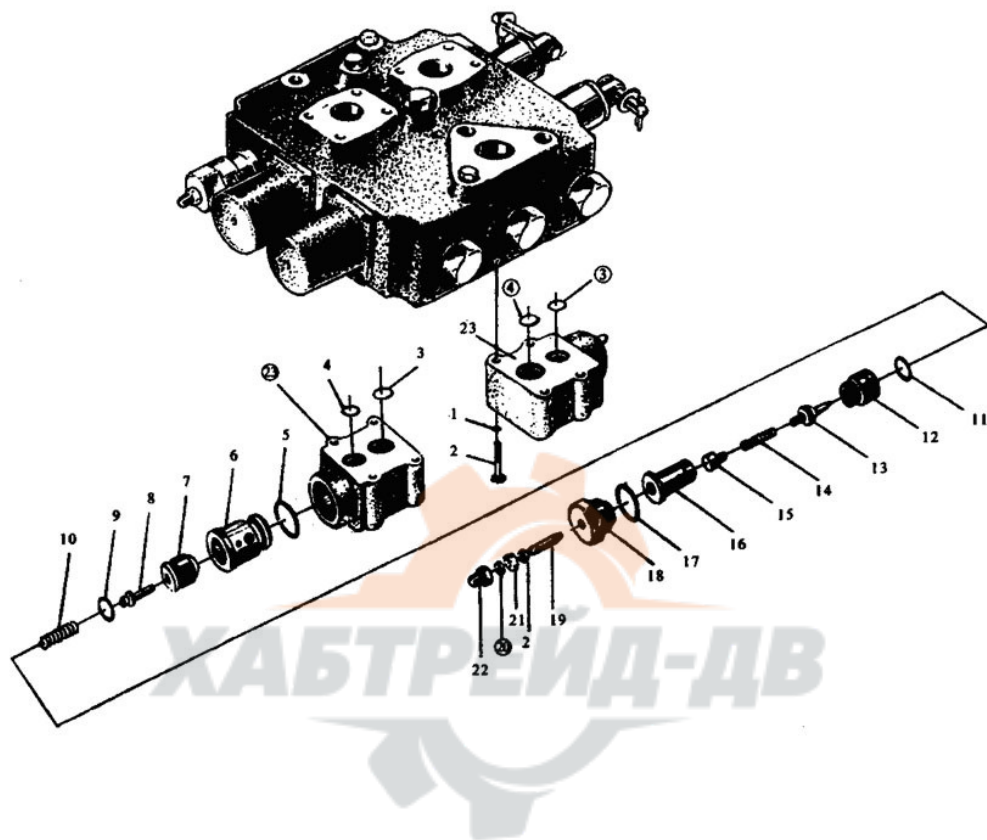

大小腔双作用安全阀

DUALACTION SAFELY VALVE

序号 Index No.	件 号 Part No.	名 称 Description	数量 Q'ty
17—1	GB93-87	弹簧垫圈 Spring washer	8
2	GB5782-86	螺栓 Bolt	8
3	GB1235-76	O型密封圈 O-ring	2
4	GB1235-76	O型密封圈 O-ring	2
5	GB1235-76	O型密封圈 O-ring	1
6		套 Bushing	1
7		主阀芯 Main spool	1
8		滑阀 Spool	1
9	GB1235-76	O型密封圈 O-ring	1
10		主阀弹簧 Main spring	1
11	GB1235-76	O型密封圈 O-ring	1
12		阀座 Valve seat	1
13		先导阀阀芯 Pilot valve spool	1
14		调压弹簧 Adjusting spring	1
15		调压弹簧座 Adjusting spring seat	1
16		先导阀阀套 Bushing of pilot valve	1
17	GB1235-76	O型密封圈 O-ring	1
18		螺塞 Screw	1
19		调压螺栓 Adjusting bolt	1
20		垫片 Gasket	2
21		螺母 Nut	1
22		锁紧螺母 Lock not	1
23		阀体 Valve body	2

第 18 图 齿轮泵

FIG.18 STEERING GEAR PUMP

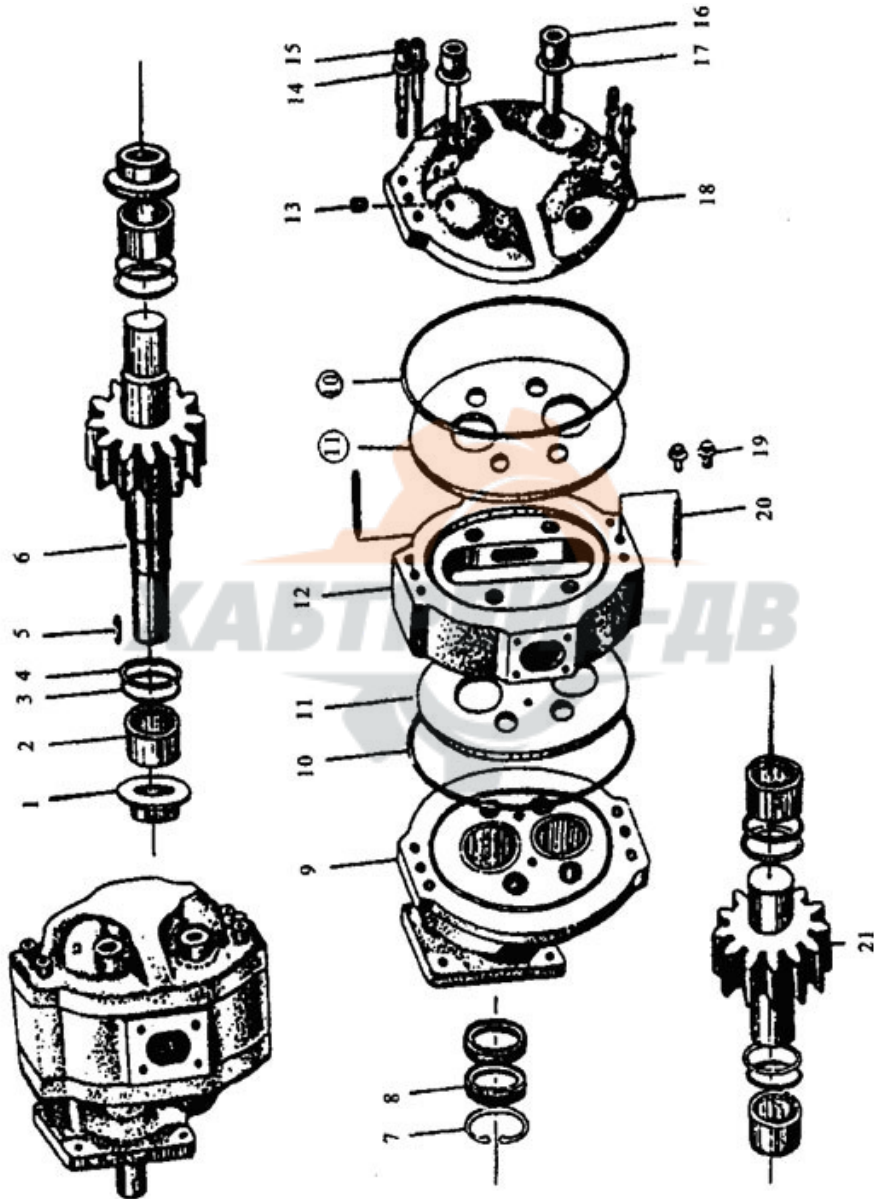

齿轮泵

STEERING GEAR PUMP

序号 Index No.	件 号 Part No.	名 称 Description		数量 Q'ty
18—1		密封套	Sleeve	2
2		轴承	Bearing	4
3	GB1235-76	O 型密封圈	O-ring	4
4		垫片	Gasket	4
5		键	Key	1
6		主动齿轮	Driving gear	1
7	GB893.1-86	孔用挡圈	Snap ring	1
8		骨架油封 SG38×58×12	Skeleton	2
9		前泵盖	Front cover	1
10	HG4-692-67	O 型密封圈	O-ring	2
11		侧板	Side plate	2
12		泵体	Pump body	1
13		螺塞 ZG1/8"	Plug	1
14	GB1235-76	弹簧垫圈	Spring washer	4
15	GB93-87	螺栓	Bolt	4
16	GB5782-86	螺栓	Bolt	4
17	GB5782-86	铜垫	Copper gasket	4
18		后泵盖	Rear cover	1
19		螺钉	Screw	2
20	GB119-86	销	Pin	2
21		从动齿轮	Driven gear	1

第 19 图 行车制动系统

FIG.19 AIR BRAKE SYSTEM

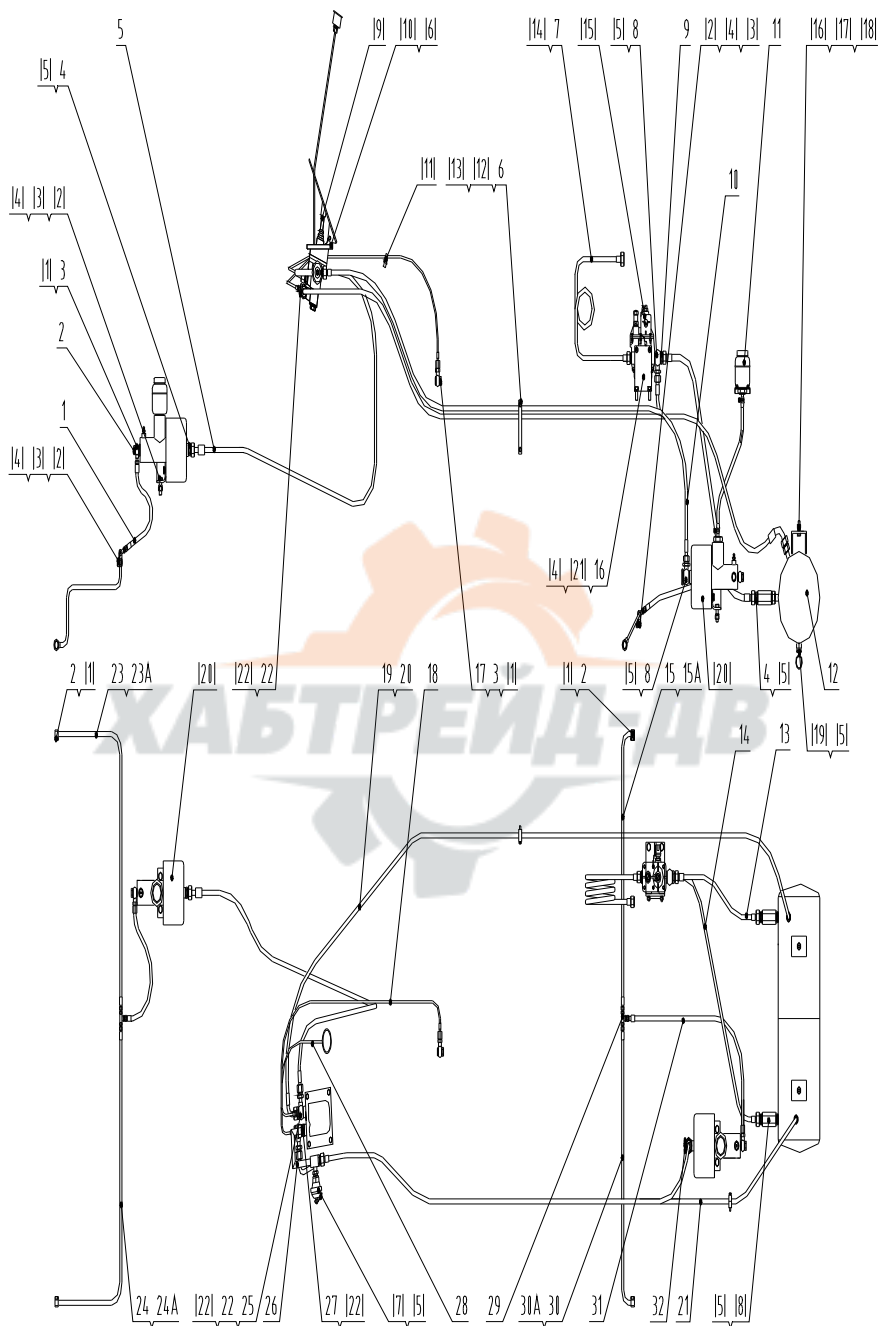

行车制动系统

AIR BRAKE SYSTEM

序号 Index No.	件 号 Part No.	名 称 Description	数量 Q'ty	
19—1	DG930A-07001	前桥制动软管	Hose front axle brake	1
2	DG930A-07002	铰接螺栓	Articulation bolt	6
3	DG930A-07003	接头总成	Fitting assembly	3
4	DG930A-07004	接头体	Fitting	3
5	DG930A-07005	进气管	Air inlet hose	1
6	DG930A-07006	管卡	Clamp for tube	3
7	DG930A-07007	出气管	Air outlet pipe	1
8	DG930A-07008	接头总成	Fitting assembly	2
9	DG930A-07009	铰接螺栓	Articulation bolt	1
10	DG930A-07010	进气管	Air inlet hose	1
11	ZL30E-07050	加油杯总成	Oil-nipple assembly	1
12	DG930A-07012	储气筒总成	Air reservoir assembly	1
13	DG930A-07013	进气管	Air inlet hose	1
14	DG930A-07014	进气管	Air inlet hose	1
15	DG930A-07015	后桥刹车管	Oil pipe rear axle brake	1
16	DG930A-07016	支架	Fixing bracket	1
17	ZL30E-07026	铰接螺栓	Articulation bolt	1
18	DG930B-07018	出气管	Air outlet pipe	1
19	DG930A-07019	出气管	Air outlet pipe	1
20	DG930A-07034	接头体	Fitting	1
21	DG930A-07033	进气管	Air inlet hose	1
22	DG930A-07022	铰接螺栓	Articulation bolt	2
23	DG930A-07023	前桥刹车管	Oil pipe front axle brake	1
24	DG930A-07024	前桥刹车管	Oil pipe front axle brake	1
25	DG930A-07025	接头总成	Fitting assembly	2
26	DG930A-07026	过渡接头	Fitting	1
27	ZL30E-07032	接头体	Fitting	1
28	DG930A-07028	进气管	Air inlet hose	1
29	DG930A-07029	三通接头	“T”Connector	2
30	DG930A-07030	后桥刹车管	Oil pipe rear axle brake	1
31	DG930A-07031	后桥制动软管	Hose, rear axle brake	1
32	DG930A-07032	铰接螺栓	Articulation bolt	1
15A	DG930A-07015A	后桥刹车管	Oil pipe rear axle brake	1
23A	DG930A-07023A	前桥刹车管	Oil pipe front axle brake	1
24A	DG930A-07024A	前桥刹车管	Oil pipe front axle brake	1
30A	DG930A-07030A	后桥刹车管	Oil pipe rear axle brake	1

第 19 图 行车制动系统

FIG.19 AIR BRAKE SYSTEM

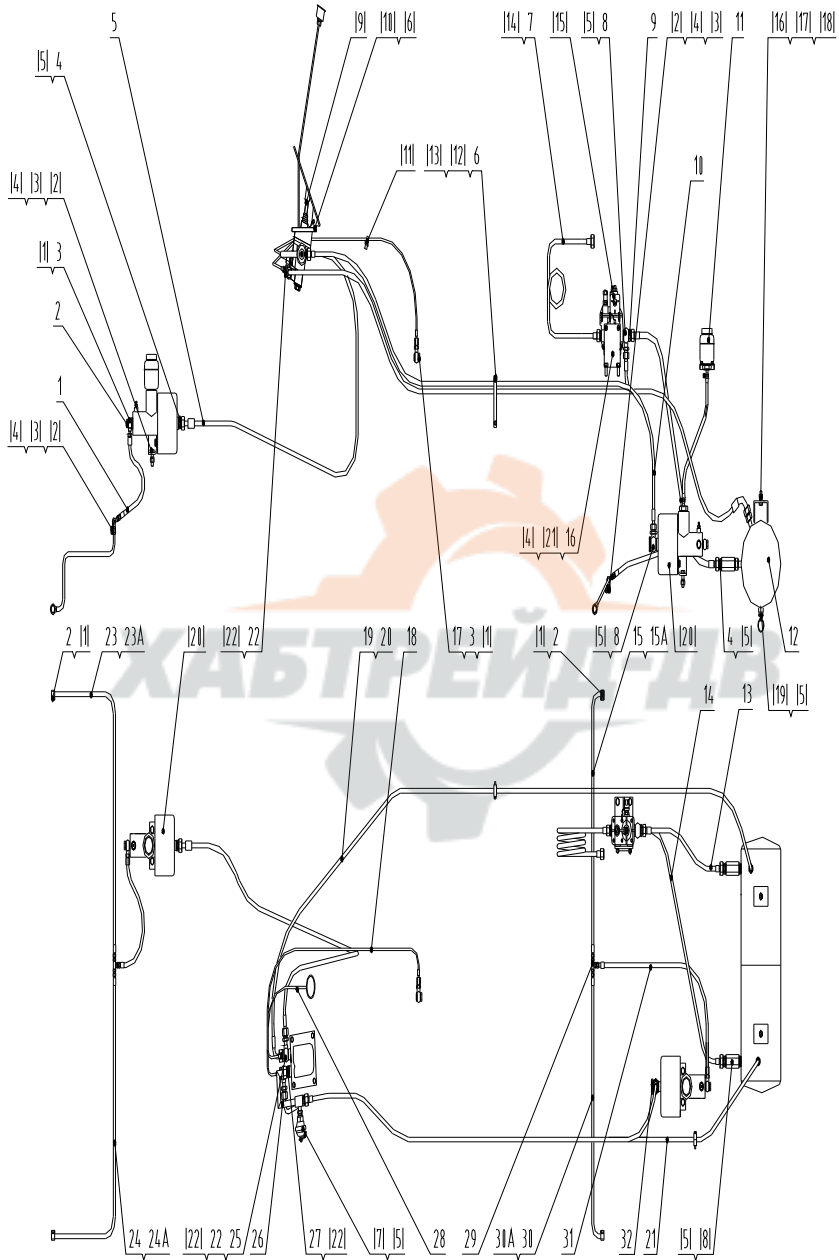

行车制动系统

AIR BRAKE SYSTEM

序号 Index No.	件 号 Part No.	名 称 Description	数量 Q'ty	
19— (1)	JB982-77	组合垫圈 12	Lock washer	14
(2)	GB5781-86	螺栓 M12×30	Bolt	6
(3)	GB6170-86	螺母 M12	Nut	6
(4)	GB93-87	垫圈 12	Spring washer	8
(5)	JB982-77	组合垫圈 22	Lock washer	10
(6)	01643-30823	垫圈 8	Spring washer	4
(7)	JN150-3720001	制动灯开关	Brake lamp switch	1
(8)	MQPs-3525001	单向阀	Check valve	2
(9)	JN161BK-3514001	气制动阀	Air brake valve	1
(10)	01010-50820	螺栓 M8×20	Bolt	4
(11)	ZD200×8	扎带	Clip	1
(12)	GB5781-86	螺栓 M6×40	Bolt	6
(13)	GB93-87	垫圈 6	Spring washer	6
(14)	JB982-77	组合垫圈 14	Lock washer	1
(15)	SH380A-3511002	油水分离器组合 阀	Combined valve of water	1
(16)	GB 6170-86	螺母 M10	Nut	2
(17)	GB 93-87	垫圈 10	Spring washer	2
(18)	GB 5781-86	螺栓 M10×25	Bolt	2
(19)	STR-3533002	手动放水阀	Manually controlled drain valve	2
(20)	ZL20A	空气加力泵	Air boosting pump	2
(21)	GB 5781-86	螺栓 M12×20	Bolt	2
(22)	JB982-77	组合垫圈 18	Lock washer	6

第 20 图 空气加力泵

FIG.20 AIR BOOSTER

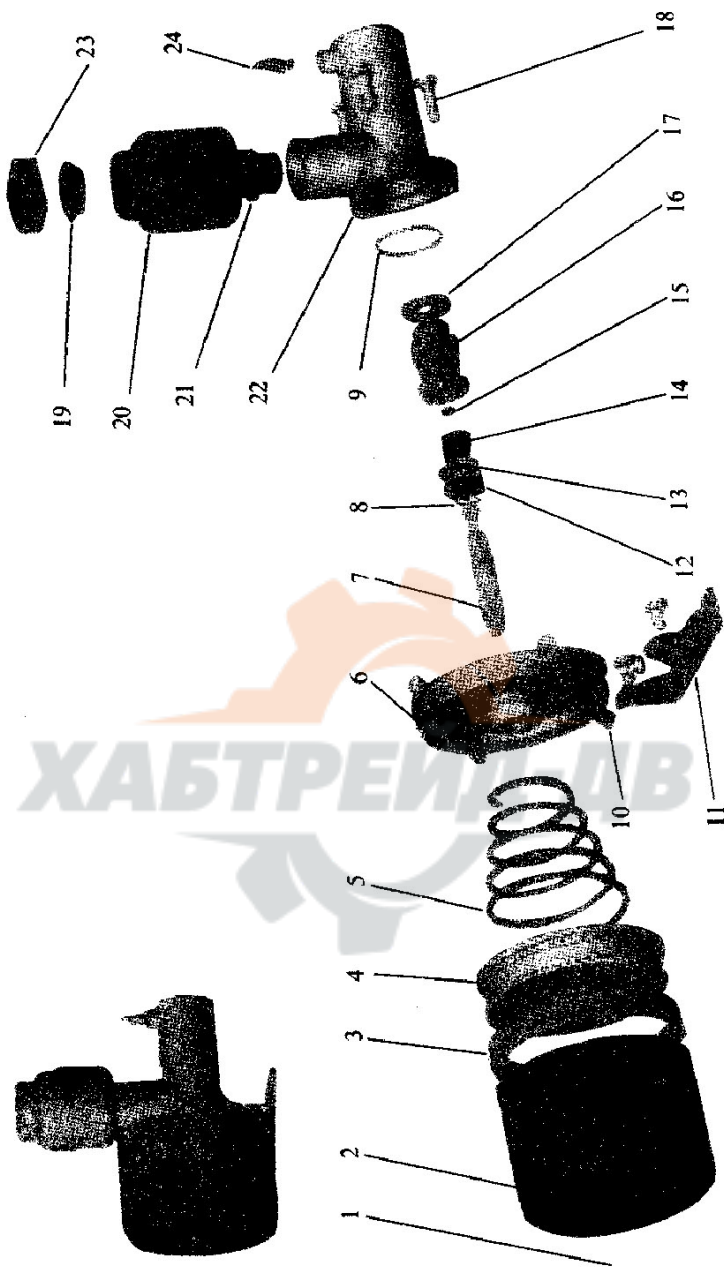

空气加力泵

AIR BOOSTER

序号 Index No.	件 号 Part No.	名 称 Description	数量 Q'ty
20—1	150-3519014	焊接螺母 Welding nut	1
2	ZL20A-3510011	气缸体 Cylinder tube	1
3	ZL20A-3410021	活塞皮圈 Piston ring	1
4	ZL20A-3510022	气活塞 Air piston	1
5	XM60-3510035	回位弹簧 Back spring	1
6	ZL20A-3510033	联接盖 Coupling cover	1
7	ZL20A-3510023	推杆 Impulsing rod	1
8	GB3452.1-92	O 型圈 O-ring	1
9	ZL20A-3510034	O 型圈 O-ring	1
10	GB5783-86	螺栓 Bolt	6
11	XM60-3510081	安装支架 Fixing bracket	1
12	ZL20A-3510031	中心密封圈 Central ring	1
13	GB893.1-86	孔用挡圈 Snap ring for vent	1
14	XM60-3510071	推杆座 Impulsing seat	1
15	980S-3510115	进油阀门 Oil -inlet valve	1
16	ZL20A-3510042	液压活塞 Cylinder piston	1
17	ZL20A-3510041	液压皮圈 Cylinder ring	1
18	GB5783-86	螺栓 Bolt	3
19	XM60-3510044	滤网 Filter net	1
20	XM60-3510043	油杯 Oil cup	1
21	XM60-3510041	油杯螺塞 Plug	1
22	ZL20A-3510035	液压缸体 Cylinder tube	1
23	XM60-3510045	油杯盖 Cover	1
24	TD50A-D-3510037	放气螺钉 Screw	1

第 21 图 气制动阀

FIG.21 BRAKE VALVE

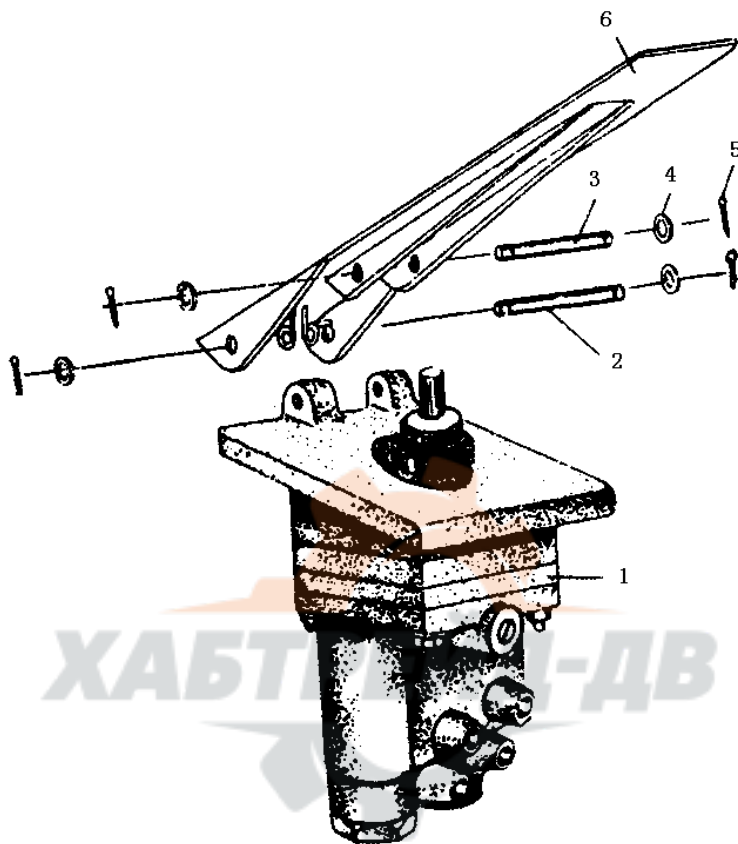

气制动阀

BRAKE VALVE

序号 Index No.	件 号 Part No.	名 称 Description	数量 Q'ty
21—1	N161BK-3514001	双腔气制动阀 Tow-circuit master brake valve	1
2		销轴 Pin	1
3		销轴 Pin	1
4	GB95-85	垫圈 Washer	4
5	GB91-86	开口销 $\Phi 2 \times 20$ Pin	4
6		制动踏板 Brake pedal	1



第 22 图 手制动系统

FIG.22 HAND BRAKE SYSTEM

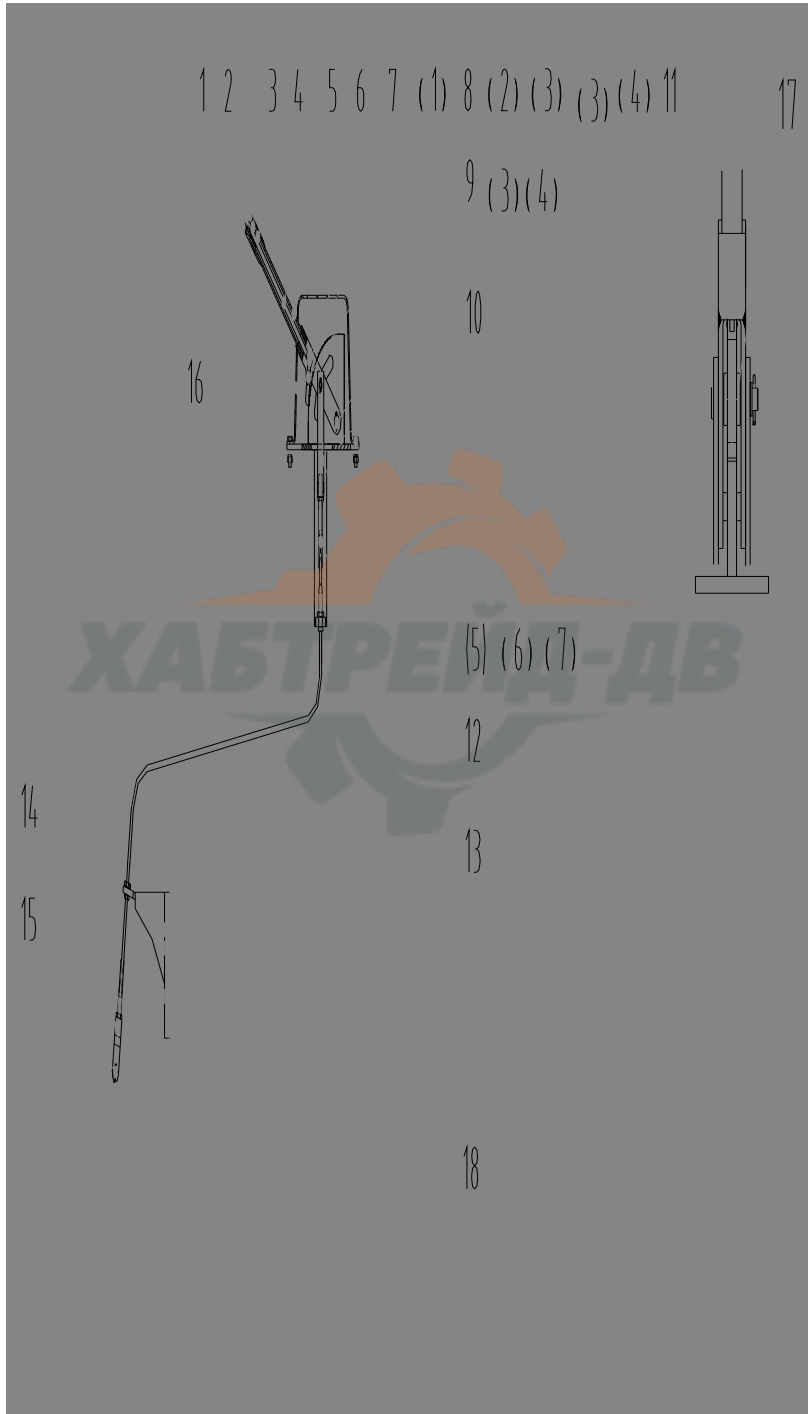

手制动系统

HAND BRAKE SYSTEM

序号 Index No.	件 号 Part No.	名 称 Description	数量 Q'ty
22—1	ZL30F-08001	螺母 Nut	1
2	ZL30F-08002	螺帽 Nut cap	1
3	ZL30F-08003	弹簧 Spring	1
4	ZL30F-08004	弹簧座 Spring seat	1
5	ZL30F-08005	杆 Shank	1
6	ZL30F-08006	操纵杆 Control arm	1
7	ZL30F-08007	止动爪 Brake claw	1
8	ZL30F-08008	销轴 Pin	1
9	ZL30F-08009	销轴 Pin	1
10	ZL30F-08010	支架 Bracket	1
11	ZL30F-08011	销轴 Pin	1
12	ZL30F-08012	联接叉 Clevis	1
13	ZL30F-08013	软轴总成 Cable assembly	1
14	ZL30F-08015	联接叉 Clevis	1
15	ZL30F-08016	销轴 Pin	1
16	ZL30F-08100	罩 Cover	1
17	ZL30F-08017	套 Trap	2
18	ZL30F-08018	支架 Bracket	1
(1)	GB863.1-86	铆钉 Rivet	1
(2)	GB95-85	垫圈 6 Washer	1
(3)	GB91-86	开口销 2.5×25 Pin	3
(4)	GB95-85	垫圈 10 Washer	2
(5)	GB 6170-86	螺母 M8 Nut	4
(6)	GB5781-86	螺栓 M8×30 Bolt	4
(7)	GB93-87	垫圈 8 Spring washer	4

第 23 图

前车架总成

FIG.23 FRONT FRAME ASSEMBLY

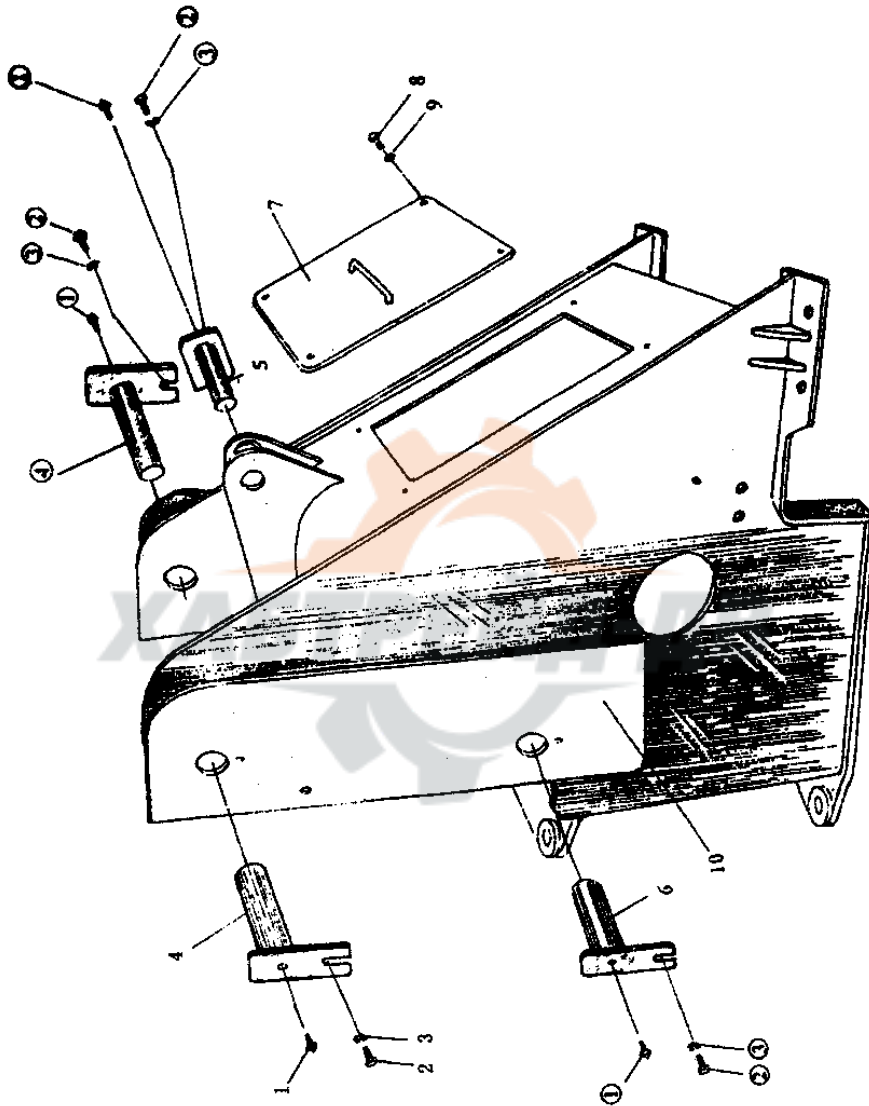

前车架总成

FRONT FRAME ASSEMBLY

序号 Index No.	件 号 Part No.	名 称 Description		数量 Q'ty
23—1	GB1152-79	油杯 M10×1	Oil cup	9
2	01016-51635	螺栓 M16×35	Bolt	5
3	01643-31645	垫圈 16	Washer	5
4	DG930A-09300	轴	Pin	2
5	DG930A-09400	轴	Pin	1
6	DG930A-09500	轴	Pin	2
7	DG930A-09200	前盖板	Front cover	1
8	01010-51020	螺栓 M10×20	Bolt	4
9	01643-31032	垫圈 10	Washer	4
10	DG930A-09100	前车架	Front frame	1



第 24 图 后车架总成

FIG.24 REAR FRAME ASSEMBLY

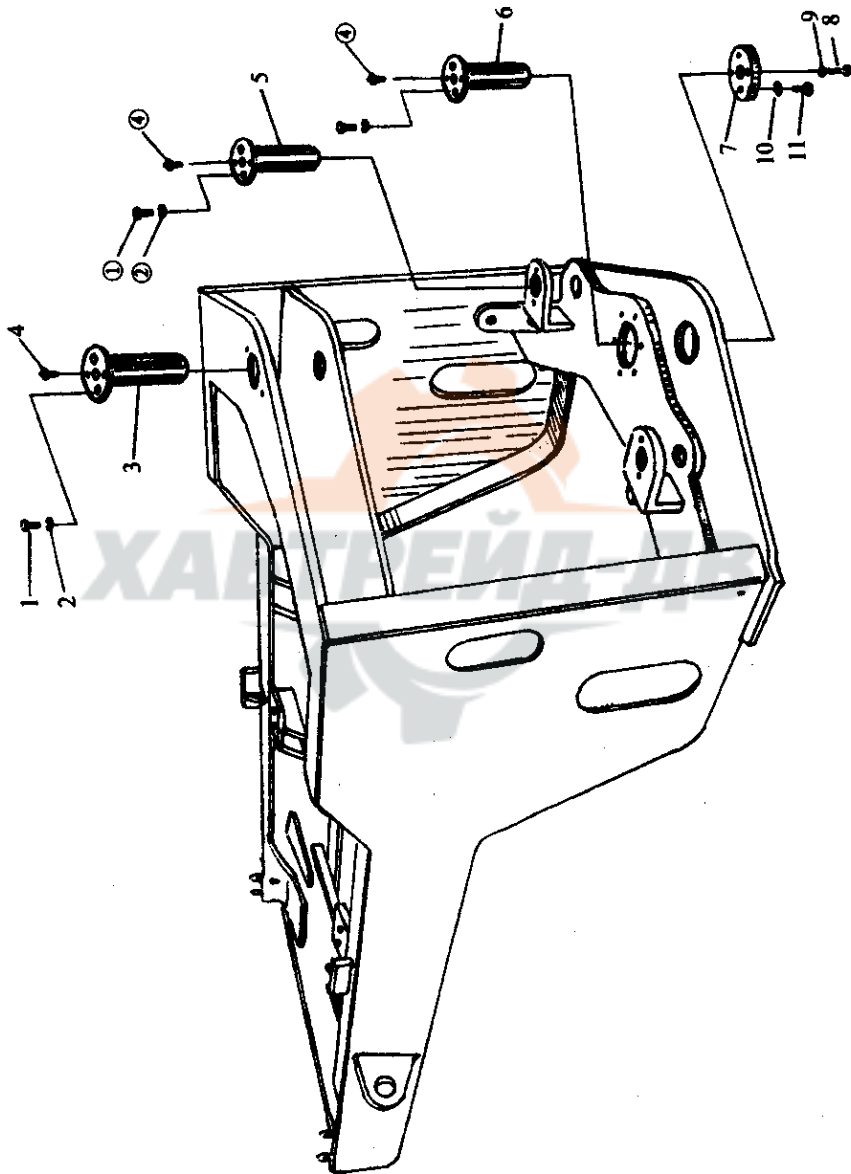

后车架总成

REAR FRAME ASSEMBLY

序号 Index No.	件 号 Part No.	名 称 Description	数量 Q'ty
24—1	01010-51225	螺栓 M12×25 Bolt	6
2	01643-31232	垫圈 12 Washer	6
3	DG930A-09600	轴 Pin	1
4	GB1152-79	油杯 M10×1 Oil cup	4
5	DG930A-09700	轴 Pin	2
6	DG930A-09009	轴 Pin	1
7	DG930A-09011	圆盘 Disc	1
8	GB9457-88	开槽螺母 M36×2 Nut	1
9	GB93-87	垫圈 36 Washer	1
10	01010-51035	螺栓 M10×35 Bolt	4
11	01643-31032	垫圈 10 Washer	4



第 25 图 工作装置总成

FIG.25 WORK IMPLEMENT ASSEMBLY

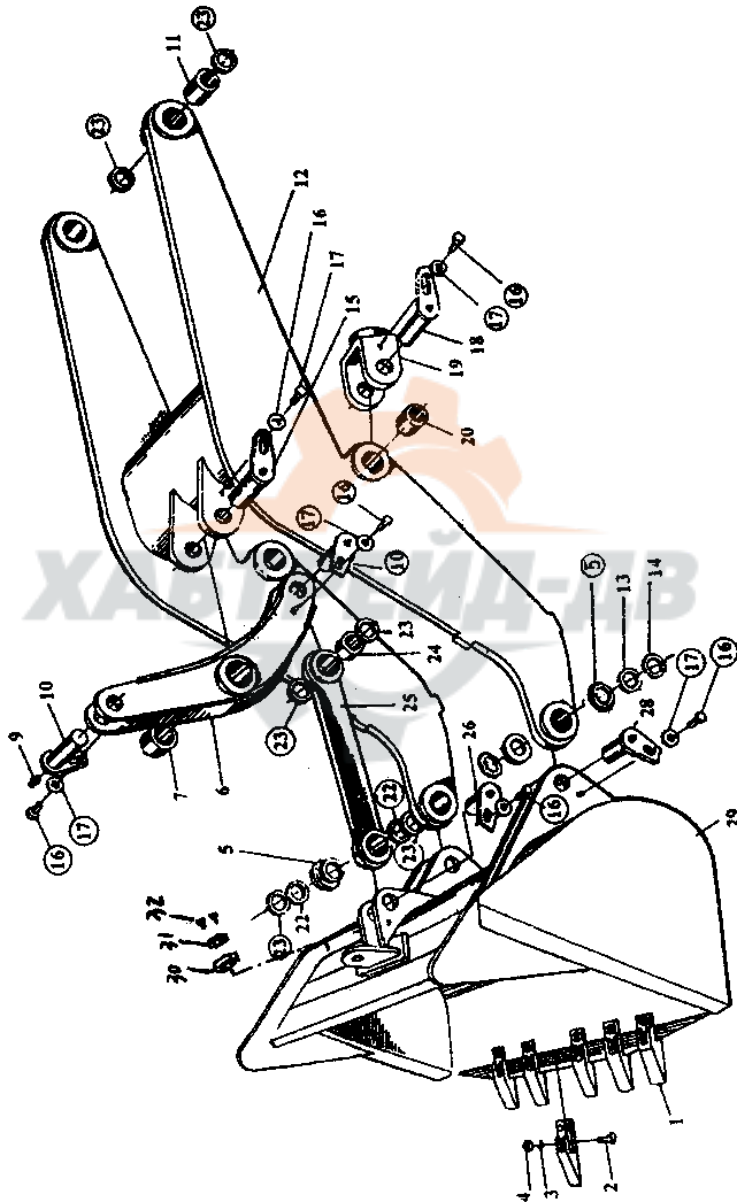

工作装置总成

WORK IMPLEMENT ASSEMBLY

序号 Index No.	件 号 Part No.	名 称 Description		数量 Q'ty
25—1	ZL30GB-11100-1	斗齿	Teeth	6
2	ZL30GB-11100-2	角斗齿	Corner bucket teeth	2
3	GB8-88	螺栓 M20×65	Bolt	16
4	GB93-87	垫圈 20	Washer	16
5	GB56-86	螺母 M20	Nut	16
6	GB304.5-81	关节轴承 GE60ES	Knuckle bearing	1
7	ZL30GII-11300	摇臂	Rocker arm	1
8	ZL30GII-11001	轴套	Bush	1
9	GB1152-79	油杯 M10×1	Oil cup	8
10	ZL30GII-11500	轴	Pin	2
11	ZL30GII-11007	轴套	Bush	2
12	ZL30GII-11400	动臂	Lift arm	1
13	ZL30GII-11002	挡盖	Retainer	4
14	SJM03-1	防尘圈 60	Dust bust	6
15	ZL30GII-11900	轴	Pin	1
16	GB93-87	垫圈 16	Washer	16
17	GB5783-86	螺栓 M16×30	Bolt	8
18	ZL30GII-11600	轴	Pin	2
19	ZL30GII-11005	连接叉	Clevis	2
20	ZL30GII-11004	轴套	Bush	2
22	ZL30GII-11003	挡盖	Retainer	2
23	GB1235-76	O型密封圈 65×3.1	O-ring	2
24	ZL30GII-11006	轴套	Bush	1
25	ZL30GII-11200	连杆	Link assembly	1
26	ZL30GII-11700	轴	Pin	1
28	ZL30GII-11800	轴	Pin	2
29	ZL30GII-11100	铲斗	Bucket	1
30	ZL30GII-11009	调整垫	Adjusting waster	1 组
31	ZL30GII-11010	压板	Pressure plate	6
32	GB5783-86	螺栓 M16×45	Bolt	8

第 26 图 变矩器传动液压系统

FIG.26 TORQUE CONVERTER SYSTEM

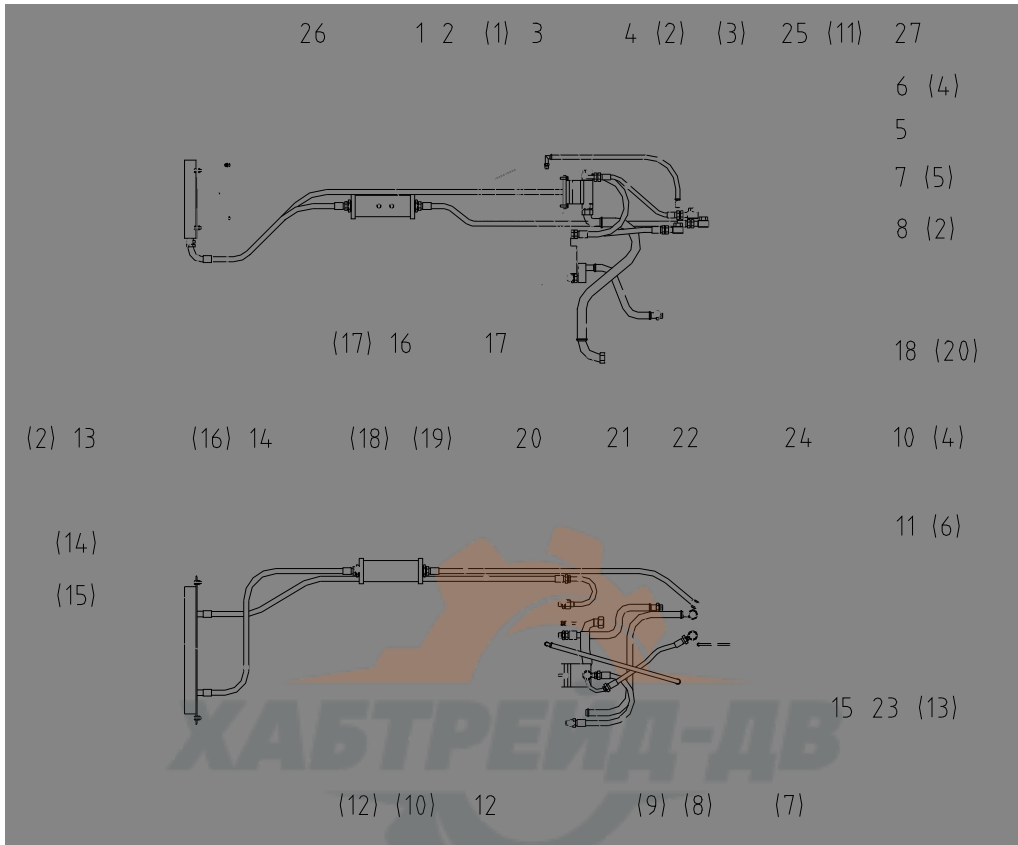

变矩器传动液压系统

TORQUE CONVERTER SYSTEM

序号 Index No.	件 号 Part No.	名 称 Description	数量 Q'ty
26—1	ZL30G-12001	接头体 Fitting	1
2	ZL30G-12002	回油接头 Oil return terminal	1
3	ZL30G-12003	铰接接头总成 Joint assembly	1
4	ZL30G-12004	铰接螺栓 Joint bolt	1
5	ZL30G-12005	铰接接头总成 Joint assembly	1
6	ZL30G-12006	铰接螺栓 Joint bolt	2
7	ZL30G-12007	回油管 φ25 Oil return hose	1
8	ZL30G-12008	回油接头 Oil return terminal	1
9	ZL30G-12009	聚氨脂管总成 Polyester outlet hose	1
10	ZL30G-12010	接头体 Fitting	1
11	ZL30G-12011	淋油胶管 φ10 Pour oil hose	1
12	ZL30G-12012	接头体 Fitting	1
13	ZL30G-12013	接头体 Fitting	2
14	ZL30G-12014	接头体 Fitting	2
15	ZL30G-12015	聚氨脂管总成 Polyester outlet hose	1
16	ZL30G-12016	接头体 Fitting	1
17	ZL30G-12017	钢管总成 Steel tube assembly	1
18	ZL30G-12018	吸油胶管 Inlet oil hose	1
19	ZL30G-12019	接头体 Fitting	1
20	ZL30G-12020	接头体 Fitting	1
21	ZL30G-12021	钢管总成 Steel tube assembly	1
22	ZL30G-12022	过渡接头 Connector	1
23	ZL30G-12023	防震垫 Fuel tank	2
24	ZL30G-12024	铰接接头总成 Joint assembly	1
25	ZL30G-12025	接头体 Fitting	1
26	ZL30G-12026	滤清器 Oil-filling	1
27	ZL30G-12027	接头体 Fitting	1

第 26 图 变矩器传动液压系统

FIG.26 TORQUE CONVERTER SYSTEM

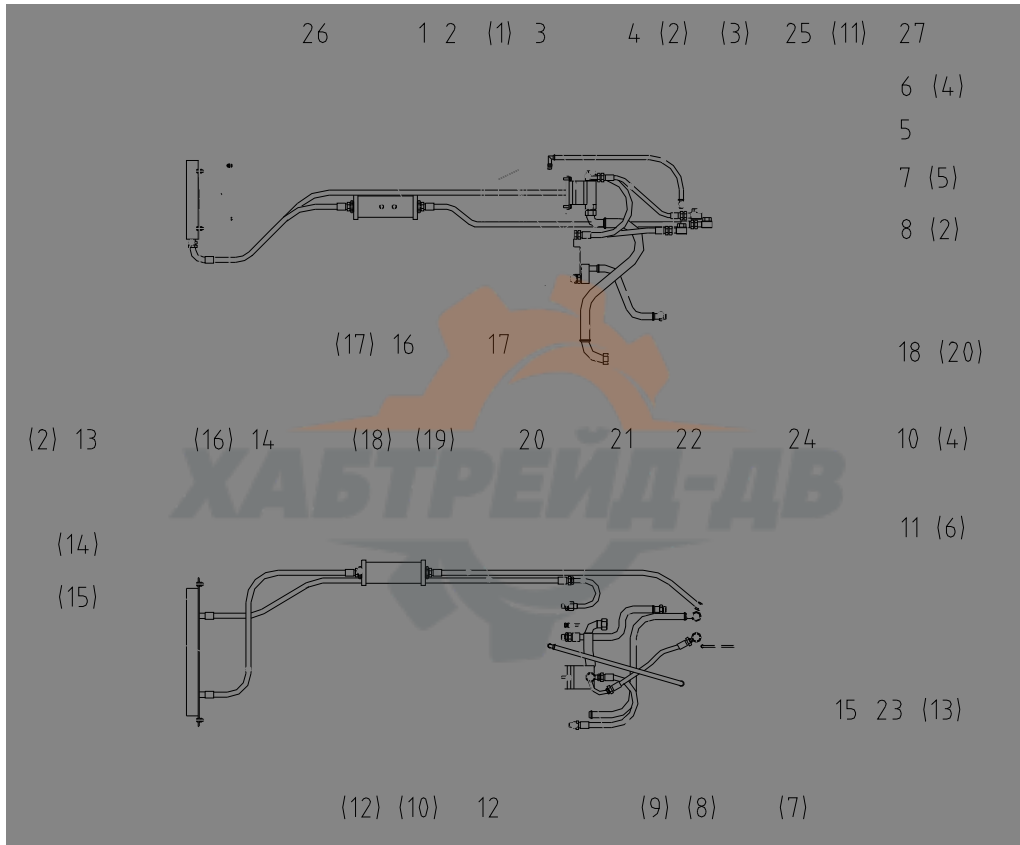

变矩器传动液压系统

TORQUE CONVERTER SYSTEM

序号 Index No.	件号 Part No.	名称 Description	数量 Q'ty	
26—(1)	CBFE-31.5	齿轮泵	Working pump	1
(2)	JB982-77	组合垫圈 27	Lock washer	5
(3)	JF100-81	胶管接头 10	Fitting assembly	1
(4)	JB982-77	组合垫圈 22	Lock washer	5
(5)		卡箍 34-38	Clamp	2
(6)		卡箍 26-30	Clamp	2
(7)	JF100-81	胶管接头 16	Fitting assembly	1
(8)	JB982-77	组合垫圈 14	Lock washer	1
(9)		油温表总成	Oil temp assembly	1
(10)	GB5783-86	螺栓 M10×30	Bolt	2
(11)		卡箍 20-24	Clamp	2
(12)	GB93-87	垫圈 10	Washer	10
(13)		密封垫圈	Gasket	1
(14)	DG936	机油冷却器	Oil cooler	1
(15)	JF100-81	胶管接头 19	Fitting assembly	1
(16)	JB982-77	组合垫圈 42	Lock washer	2
(17)	JB982-77	组合垫圈 33	Lock washer	1
(18)	JF100-81	胶管接头 19	Fitting assembly	1
(19)	JF100-81	胶管接头 19	Fitting assembly	1
(20)		卡箍 45-50	Clamp	2

第 27 图 台架总成

FIG.27 PLATFORM ASSEMBLY

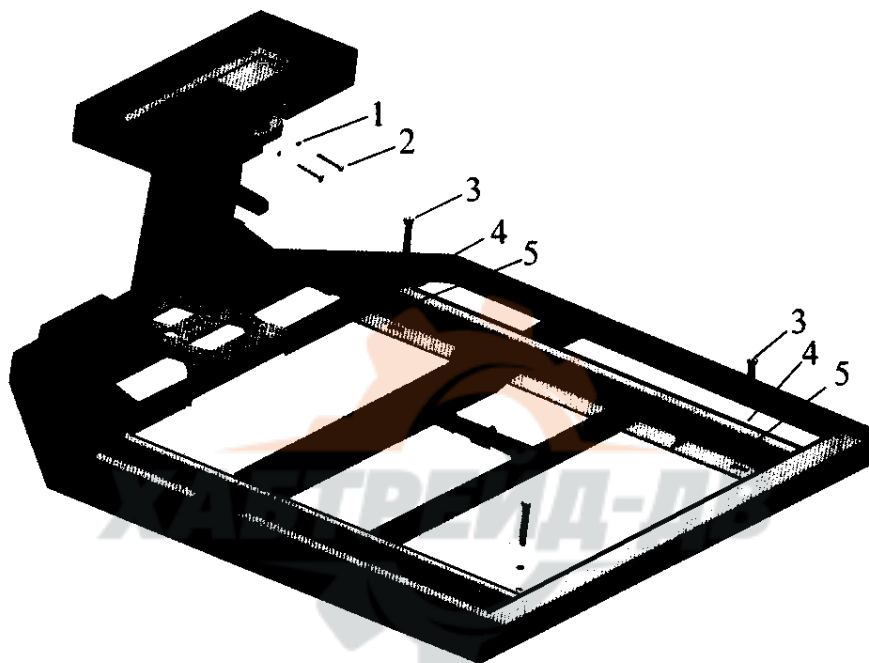

台架总成

PLATFORM ASSEMBLY

序号 Index No.	件 号 Part No.	名 称 Description	数量 Q'ty
27—1	GB93-87	垫圈 10 Spring washer	2
2	GB5781-86	螺栓 M10×45 Bolt	2
3	GB5782-86	螺栓 M20×100 Bolt	4
4	GB93-87	垫圈 20 Spring washer	4
5	GB889-86	螺母 M20 Nut	4



第 28 图 驾驶室

FIG.28 DRIVER' S CAB

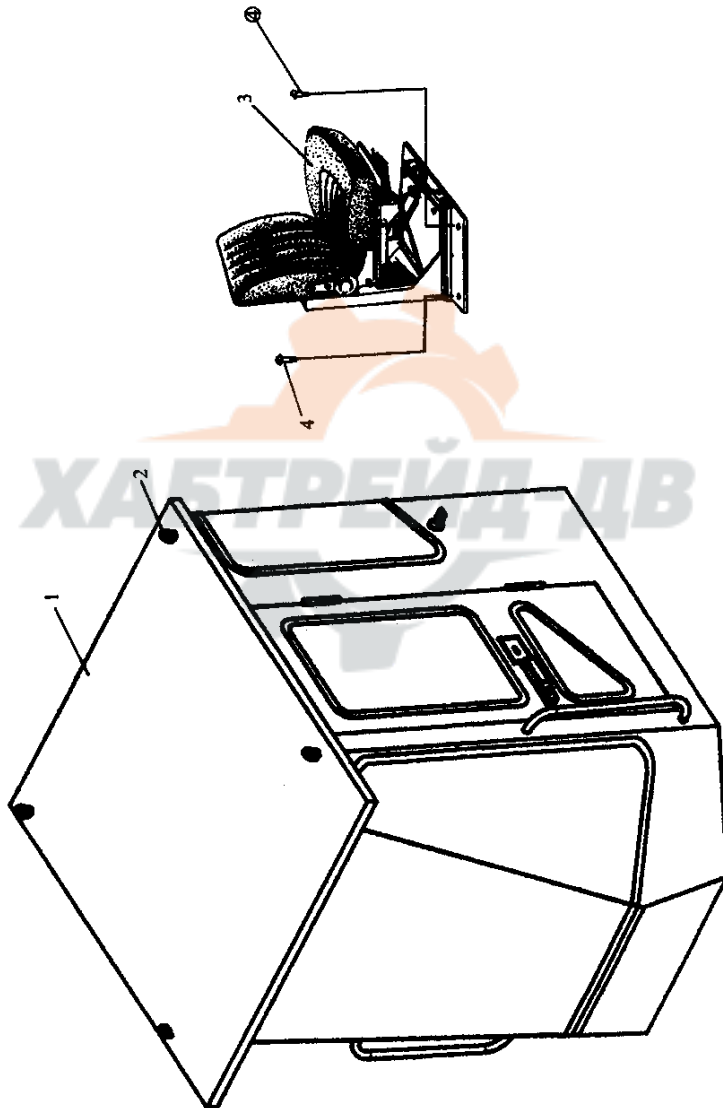

驾驶室

DRIVER' S CAB

序号 Index No.	件 号 Part No.	名 称 Description	数量 Q'ty
28—1		驾驶室 Driver' s cab	1
2	GB825-86	吊环螺栓 M12 Bolt	4
3		驾驶室座椅 Driver' s seat	1
4	GB5782-86	螺栓 M10×25 Bolt	4



第 29 图 电器系统

FIG.29 ELECTRIC WIRING SYSTEM

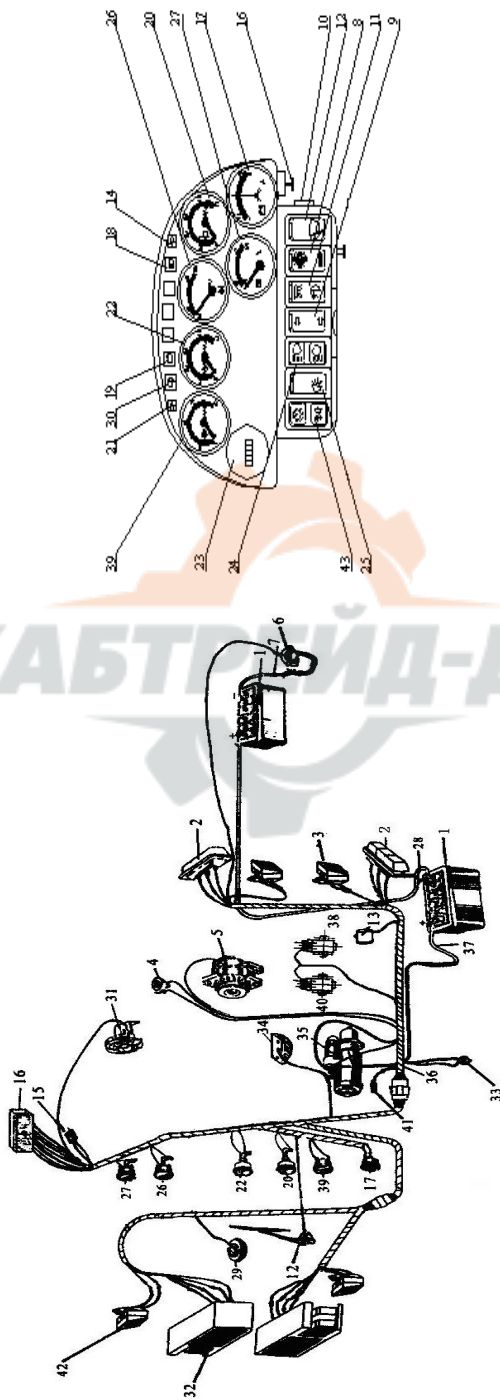

电器系统

ELECTRIC WIRING SYSTEM

序号 Index No.	件 号 Part No.	名 称 Description	数量 Q'ty	
29—1	N200S	蓄电池	Storage battery	2
2	633	后组合大灯	Combined rear signai lamps	2
3	HG	后大灯	Rear illuminating lamps	2
4	JN150-3720001	刹车开关	Stopping switch	1
5		发电机总成	Alternator	1
6	DK2312	电源开关	General power switch	1
7	ZL30G-15002	搭铁线	Ground wire	1
8	JK932-148	风扇, 暖风开关	Warm wind 、 fan switch	1
9	JK932-148	转向开关	Steering switch	1
10	JK406C	点火开关	Start-up switch	1
11	JK932-002	顶灯开关	Top light switch	1
12	ZD2232	刮水器总成	Wiper assembly	1
13	DJ221B	倒车报警器	Reversing warning buzzer	1
14	8SQS.359	右转向指示灯	Right steering indicator	1
15	SG224C	闪光器	Flasher	1
16	BX506	保险丝盒	Fuse box	1
17	DL922-2A	电流表	Charge and discharge ammeter	1
18	JK932-002	工作灯开关	Working light switch	1
19	8SQS.359	充电指示灯	Charge indicator	1
20	YY04-02	气压表	Brake system barometer	1
21	8SQS.359	左转向指示灯	Left steering indicator	1
22	YY04-02	发动机油压表	Engine oil pressure gauge	1
23		工时表	Man-hour table	1
24	JK932-026	前大灯开关	Front big lamp switch	1
25	JK932-002	后灯开关	Rear big lamp switch	1
26	SW242-2A	发动机水温表	Engine water thermometer	1
27	SW242-2B	变矩器油温表	Torque-converter oil temperature	1
28	ZL30G-15003	连接线	Connection wire	1
29	DL51A, 24V	电喇叭总成	Horn assembly	1
30		刹车指示灯	Indicator light of brake	
31	6" 24V	电风扇总成	Fan assembly	1
32	HG	前大灯	Front illuminating lamps	2
33	JK613BG	倒车报警开关	Reversing warning switch	1
34	Z-216	顶灯总成	Ceiling lamp assembly	1
35		起动机	Starting generator	1
36	ZL30G-15005D	主线束	Main wire batch	1
37	ZL30G-15004	电瓶线	Battery wire	1
38	JD26C	起动继电器	Starting relay	1
39	YY04-04	变速箱油压表	Gear-box oil pressure gauge	1
40	JD26C	预热继电器	Warm-up relay	1

第29图

电器系统

FIG.29 ELECTRIC WIRING SYSTEM

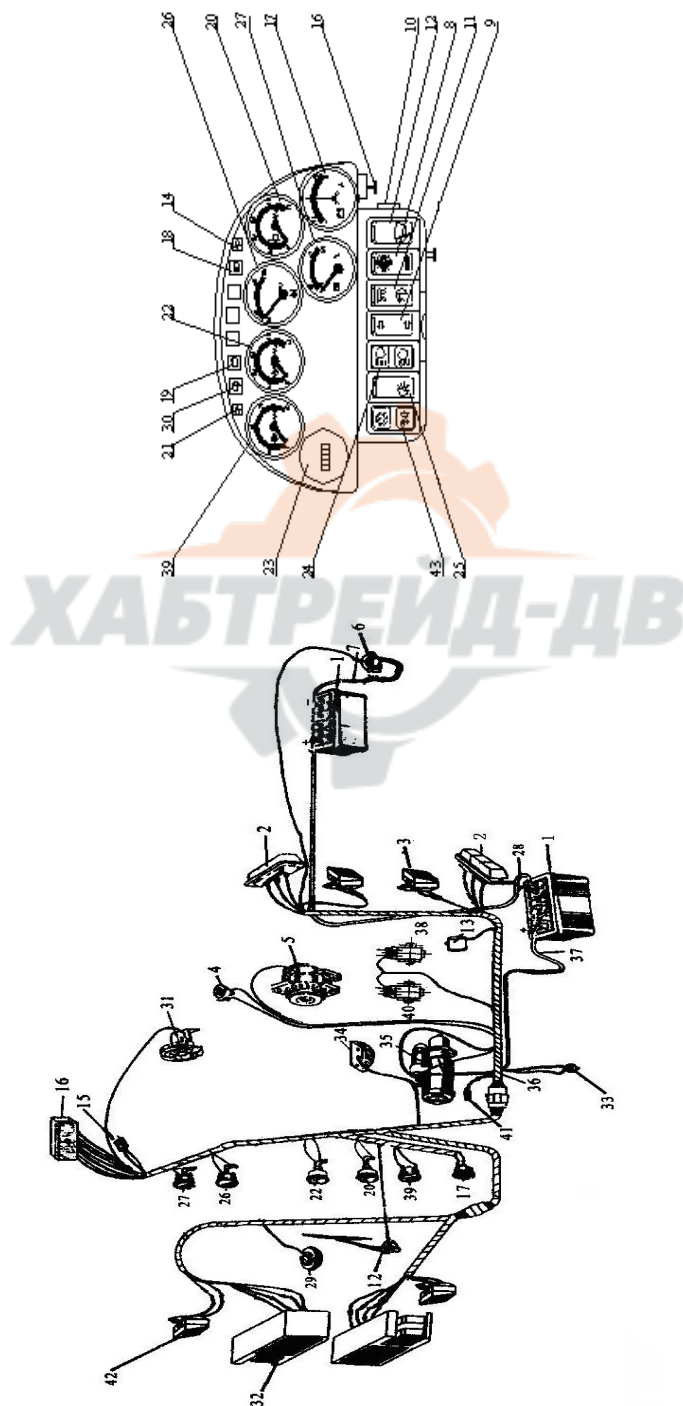

电器系统

ELECTRIC WIRING SYSTEM

序号 Index No.	件 号 Part No.	名 称 Description		数量 Q'ty
29-41	WDG1371	温度传感器	Coolant temperature sensor	2
42	HG	工作灯总成	Work lamp assembly	2
43	JK932-002	小灯/仪表灯开关	Instrument light、small light switch	1

