

SD8 推土机
SD8 DOZER

零件目录

PARTS BOOK

中华人民共和国宣化工程机械集团有限公司
XUANHUA CONSTRUCTION MACHINERY GROUP COMPANY
THE PEOPLE'S REPUBLIC OF CHINA

使用说明

1. 编制本目录是为了便于用户选用 **SD8** 推土机配件之用。关于推土机的结构及使用、维修、保养等问题,请参阅《**SD8** 推土机说明书》。
2. 本目录所列系 **SD8** 推土机除柴油机以外的全部零部件,按照推土机部件代号的顺序编排;部件图中的全部零件(包括标准件、外构件)均按序号列在相应的附表内。附表内零件的数量系指该零件在其相应部件中的数量。
3. 选用柴油机的配件时,请参阅重庆发动机厂的《**NTA855-C400** 型柴油机零件目录》。



二〇〇二年五月

Preface

1. This parts book is made for the user's conveniently selecting and using the fabricated parts of SD8 elevated sprocket dozer. For the construction, use, maintenance of the dozer refer to the 《SERVICE MANUAL FOR SD8 ELEVATED SPROCKET DOZER》.
2. The component parts listed in the parts book, except the diesel engine, are all parts of the machine. This book is graded in the order of the parts number. Within each illustration, the parts of all (including standard and purchased ones) are listed in a relevant attached chart according to the order of the parts number. The part quantity in the chart means the quantity of the part in its appropriate component.
3. When selecting and using the fabricated of the diesel engine, refer to 《PARTS CATALOG FOR NTA855-C400 DIESEL ENGINE》 published by CHONGQING DIESEL ENGINE WORKS.

May, 15, 2002

目 录 CONTENTS

序号 NO.	代号 PART NO.	名 称 NAME	页次 PAGE	备注 EMARK
1	1T01000	发动机总成	ENGINE ARRANGEMENT	1-1
2	1T01100	水散热器组件	RADIATOR GROUP	1-3
3	1T01107	油散热器总成	OIL COOLER ASSEM.	1-5
4	1T01200	风扇护罩组件	FAN GUARD GROUP	1-7
5	1T01300	柴油机组件	DIESEL ENGINE GROUP	1-9
6	1T01400	分动箱	FLYWHEEL HOUSING GROUP	1-12
7	1T02000	变矩器	TORQUE CONVERTER	2-1
8	1T02048	出口压力阀	OUTLET PRESSURE VALVE	2-7
9	1T03000	变速总成	TRANSMISSION ARRANGMENT	3-1
10	1T03010	动力换档变速箱	TRANSMISSION	3-3
11	1T03200	中央传动	CENTRAL DRIVE	3-8
12	1T03300	后盖组件	REAR COVER GROUP	3-12
13	1T03400	联轴器总成	UNIVERSAL JOINT ASSEMBLE	3-15
14	1T04000	转向与制动离合器	STEERING & BRAKE CLUTCH	4-1
15	1T05000	终传动	FINAL DRIVE	5-1
16	1T06000	顶罩—前保护板	TOP COVER-PRONT GUARD	6-1
17	1T07000	机架—后桥箱	FRAME-BEVEL GEAR CASE	7-1
18	1T07049	加油管总成	OIL PIPE ASSEM.	7-4
19	1T07057	油尺总成	DIPSTICK ASSEM.	7-6
20	1T07092	平衡梁总成	EQUALIZER BAR ASSEM.	7-8
21	1T08000	左右弯板组件	LEFT & RIGHT ELBOW PLATE GROUP	8-1
22	1T09000	变速阀操纵	TRANSIMMISSION VALVE CONTROL	9-1

序号 NO.	代号 PART NO.	名 称 NAME	页次 PAGE	备注 EMARK
23	1T10000	转向制动操纵	STEERING BRAKE CONTROL	10-1
24	1T11000	油门操纵	GOVERNOR CONTROL GROUP	11-1
25	1T12000	底盘液压系统	HYDRAULIC SYSTEM	12-1
26	0T12200	转向制动阀	STEERING BRAKE VALVE	12-6
27	1T12100	变速箱控制阀总成	TRANSMISSION CONTROL VALVE ASSEM.	12-14
28	0T12192	顺序阀	SEQUENCE VALVE	12-18
29	1T12055	细滤器总成	SECONDARY FILTER	12-20
30	1T12080	粗滤器总成	PRIMARY FILTER	12-22
31	1T13000	工作装置液压系统	IMPLEMENT HYDRAULIC SYSTEM	13-1
32	1T13100	工作装置操纵	IMPLEMENT CONTROL	13-6
33	1T13130	顺序阀组件	SEQUENCE VALVE GROUP	13-8
34	1T13160	铲刀控制阀	BULLDOZER CONTROL VALVE	13-10
35	1U1819-XG	推土铲控制阀 (外配套件)	BULLDOZER CONTROL VALVE(PURCHASED PARTS)	13-17
36	1T13300	油箱	OIL TANK	13-24
37	1T14000	推土装置	IMPLEMENT	14-1
38	1T14011	支臂	ARM	14-4
39	1T14025	斜支撑	LEAN BRACE	14-6
40	1T14100	侧倾缸总成	TILT CYLINDER ASSEM.	14-8
41	1T14107	侧倾油缸	TILT CYLINDER	14-10
42	HSGF-200× 178/80E	侧倾油缸(外配套件)	TILT CYLINDER (PURCHASED PARTS)	14-12
43	1T15000	仪表盘司机座总成	DASH-OPERATOR SEAT GROUP	15-1
44	1T16000	左行走系统	LEFT UNDERCARRIAGE SYSTEM	16-1

序号 NO.	代号 PART NO.	名 称 NAME	页次 PAGE	备注 EMARK
45	1T16004	左履带张紧装置	TRACK RECOIL SPRING AND CYLINDER ADJUSTMENT, LEFT	16-6
46	1T17000	右行走系统	RIGHT UNDERCARRIAGE SYSTEM	17-1
47	1T17042	右履带张紧装置	TRACK RECOIL SPRING AND CYLINDER ADJUSTMENT, RIGHT	17-6
48	1T17064	连接盘组件	CONNECTING PLATE GROUP	17-8
49	1T17084	单边支重轮总成	SINGLE FLANGE TRACK ROLLER	17-10
50	1T17092	双边支重轮总成	DOUBLE FLANGE TRACK ROLLER	17-12
51	1T17096	引导轮总成	TRACK IDLER ASSEM.	17-14
52	1T18000	驾驶室	CAB	18-1
53	1T19000	燃油系统	FUEL SYSTEM	19-1
54	1T19043	燃油管路	FUEL LINES	19-3
55	1T20000	松土装置	RIPPER ASS'Y	20-1
56	1T20100	松土液压操纵系统	RIPPING HYDRAULIC CONTROL SYSTEM	20-3
57	1T20200	转角油缸	TIP CYLINDER	20-8
58	HSG-F180× 597/80E	转角油缸	TIP CYLINDER	20-10
59	1T20250	提升油缸	LIFT CYLINDER	20-12
60	HSG-F200× 405/80E	提升油缸 I	LIFT CYLINDER I	20-15
61	1T20300	松土操纵阀	RIPPER CONTROL VALVE	20-17
62	3G1773-XG	松土器主控阀 (外配套件)	RIPPER MAIN CONTROL VALVE	20-19
63	1T21000	电气系统	ELECTRICAL SYSTEM	21-1
64	1T21033	仪表盘总成	INSTRUMENT ASSEM.	21-5
65	1T22000	多路液控换向阀	PILOT OPERATED VALVES	22-1
66	1T23000	左推土油缸总成	LEFT BULLDOZER CYLINDER ASSEM.	23-1
67	1T23004	快降阀	QUICK-DROP VALVE	23-3

序号 NO.	代号 PART NO.	名 称 NAME	页次 PAGE	备注 EMARK
68	1T23005	提升油缸	LIFT CYLINDER	23-5
69	HSG-E130 ×1485/75ZQ	提升油缸 (外配套件)	LIFT CYLINDER (PURCHASED PARTS)	23-7
70	1T24000	右推土油缸总成	RIGHT BULLDOZER CYLINDER ASSEM.	23-10
71	1T25000	空调总成	CONDITIONOR SYSTEM	25-1
72	1T26000	牵引机构	DRAWING MECHANISM	26-1

SD8 推土机 SD8 DOZER

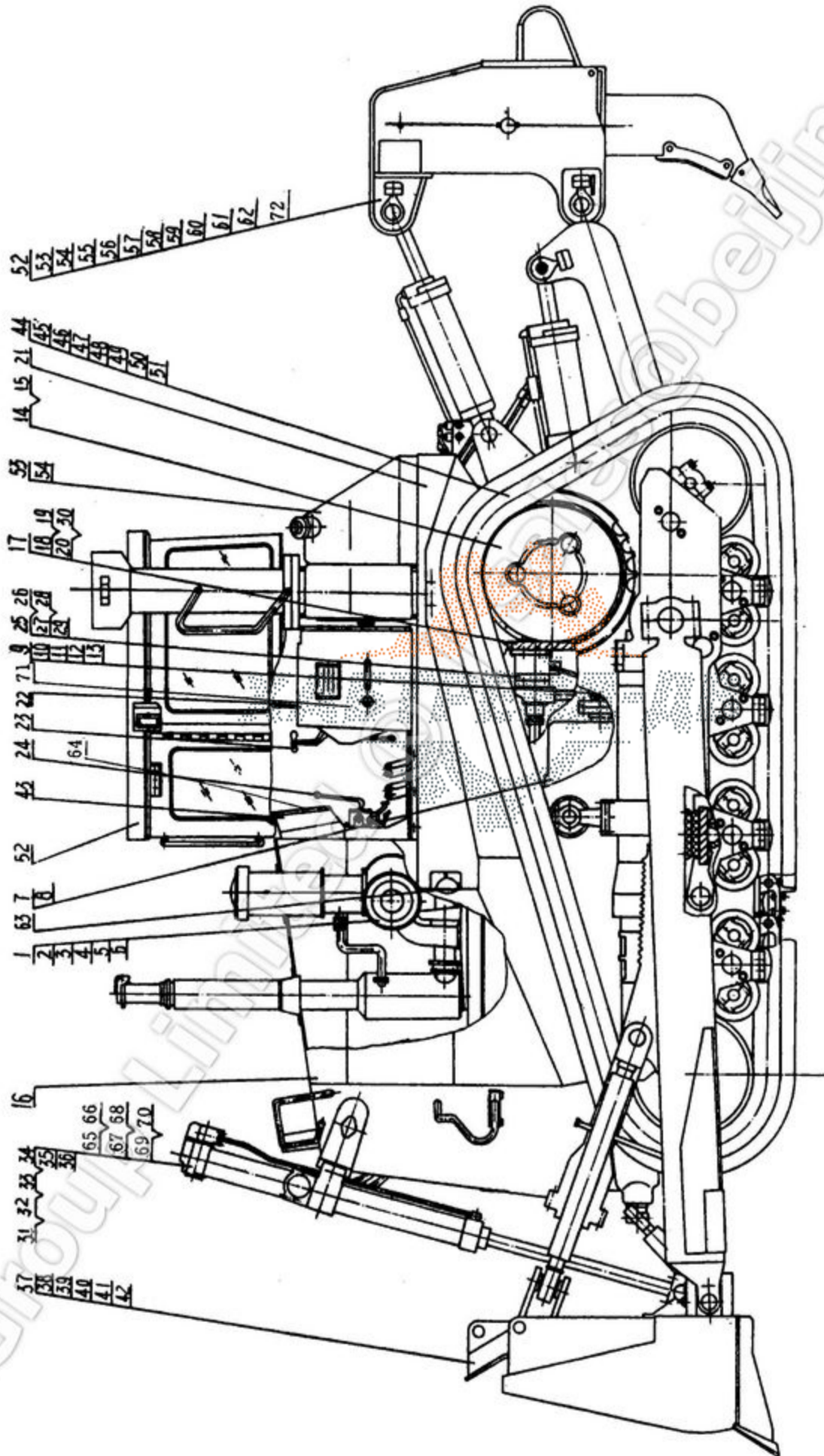

1T01000

发动机总成

ENGINE ARRANGEMENT

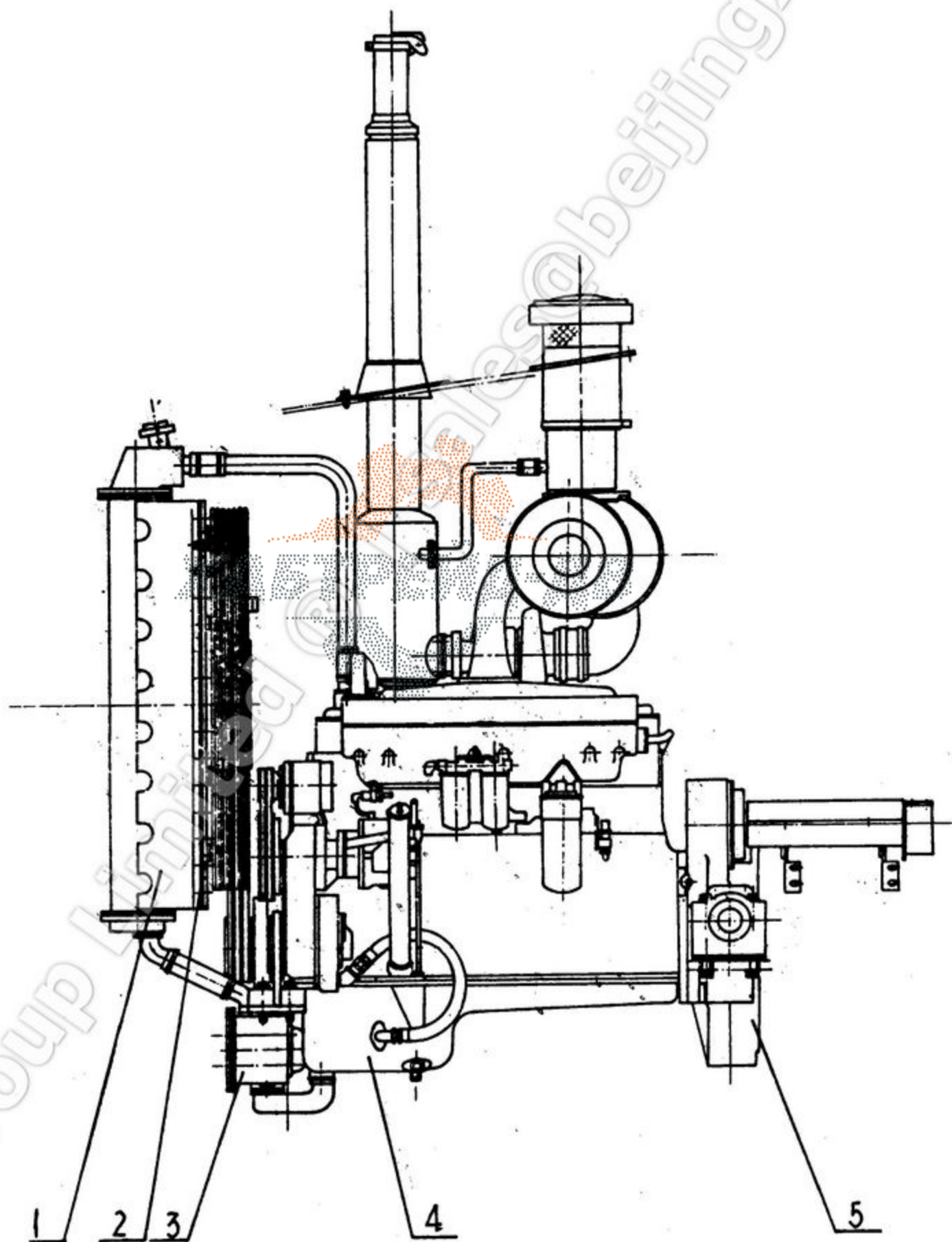

1-1

0T01000

发动机总成

ENGINE ARRANGEMENT

序号 NO.	代号 PART NO.	名 称 NAME	数量 Q' TY	备 注 REMARK
1	1T01100	水散热器组件 RADIATOR GROUP	1	
2	1T01200	风扇护罩组件 FAN GUARD GROUP	1	
3	1T01107	油散热器总成 OIL COOLER ASSEM.	1	
4	1T01300	柴油机组件 DIESEL ENGINE GROUP	1	
5	1T01400	分动箱 FLYWHEEL HOUSING GROUP	1	

1T01100

水散热器组件

RADIATOR GROUP

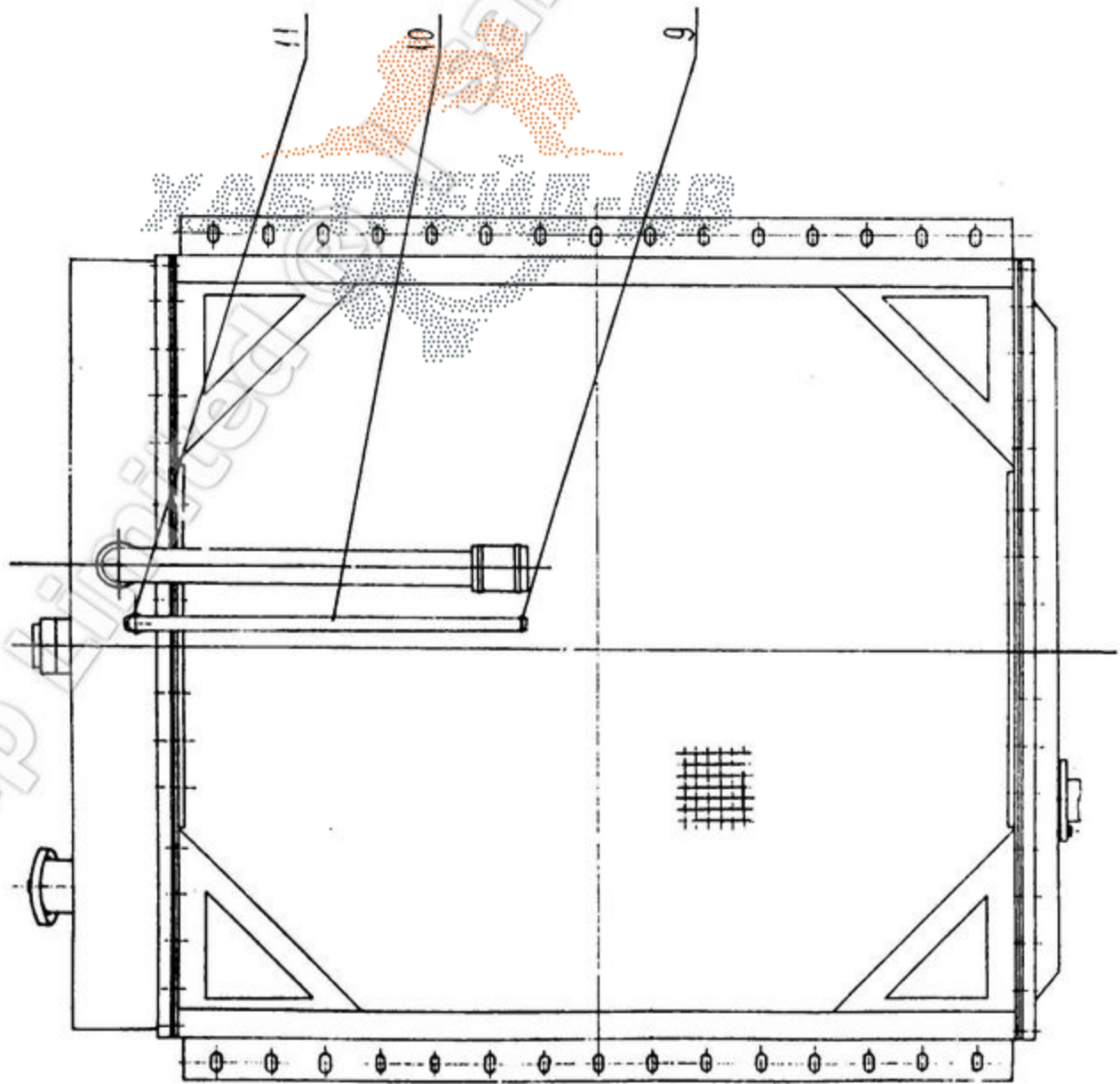
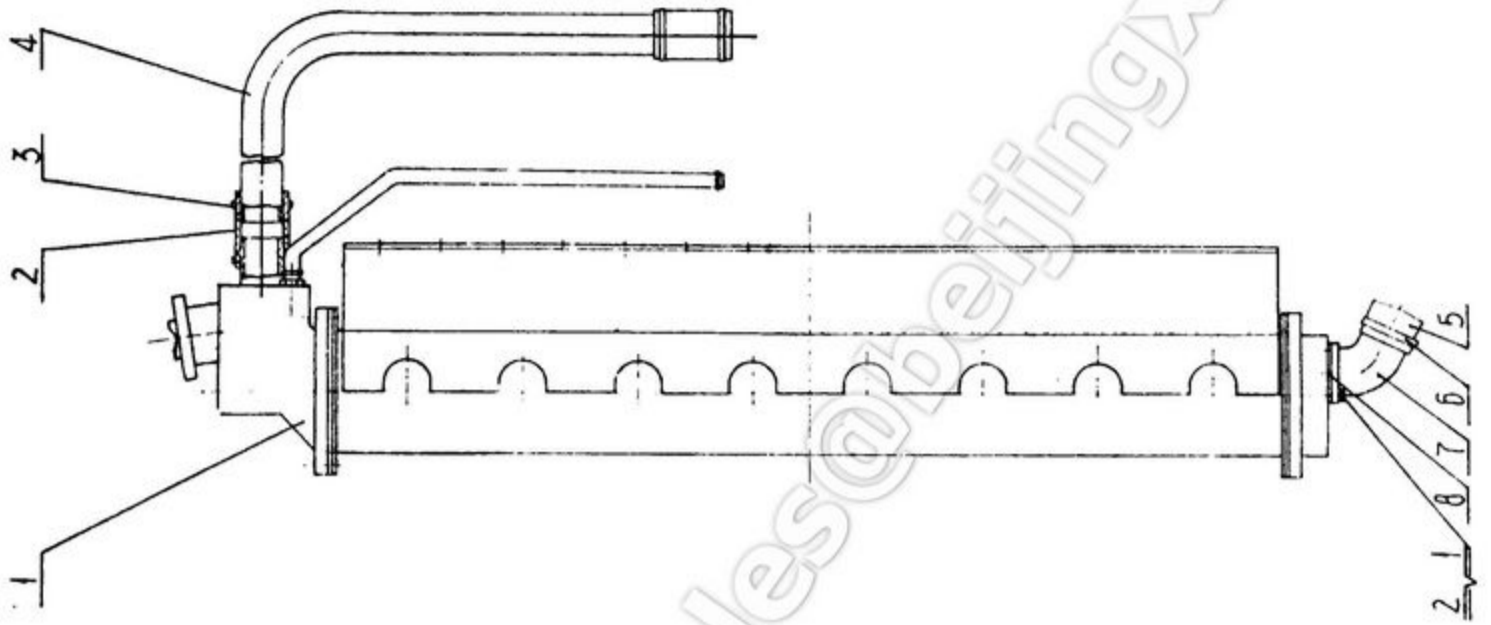

1T01100

水散热器组件

RADIATOR GROUP

序号 NO.	代号 PART NO.	名称 NAME	数量 Q' TY	备注 REMARK
1	1T01101	水散热器 RADIATOR	1	
2	0T42105	胶管 HOSE	2	
3	0T42102	喉箍 3X CLAMP 3X	4	
4	1T01104	上水管 WATER PIPE UPPER	1	
5	1T01105	胶管(二) HOSE(二)	1	
6	1T01106	喉箍 4 CLAMP 4	2	
7	1T01120	进水管 INLET WATER PIPE	1	
8	1T01111	橡胶垫(一) RUBBER GASKET(一)	1	
9	0T42107	喉箍 CLAMP	2	
10	0T42106	管 PIPE	1	
11	0T42104	接头 JOINT	1	
1	GB5783-86	螺栓 M8×25 BOLT M8×25	4	
2	GB93-87	垫圈 8 WASHER 8	4	

1T01107

油散热器组件

OIL COOLER ASSEM.

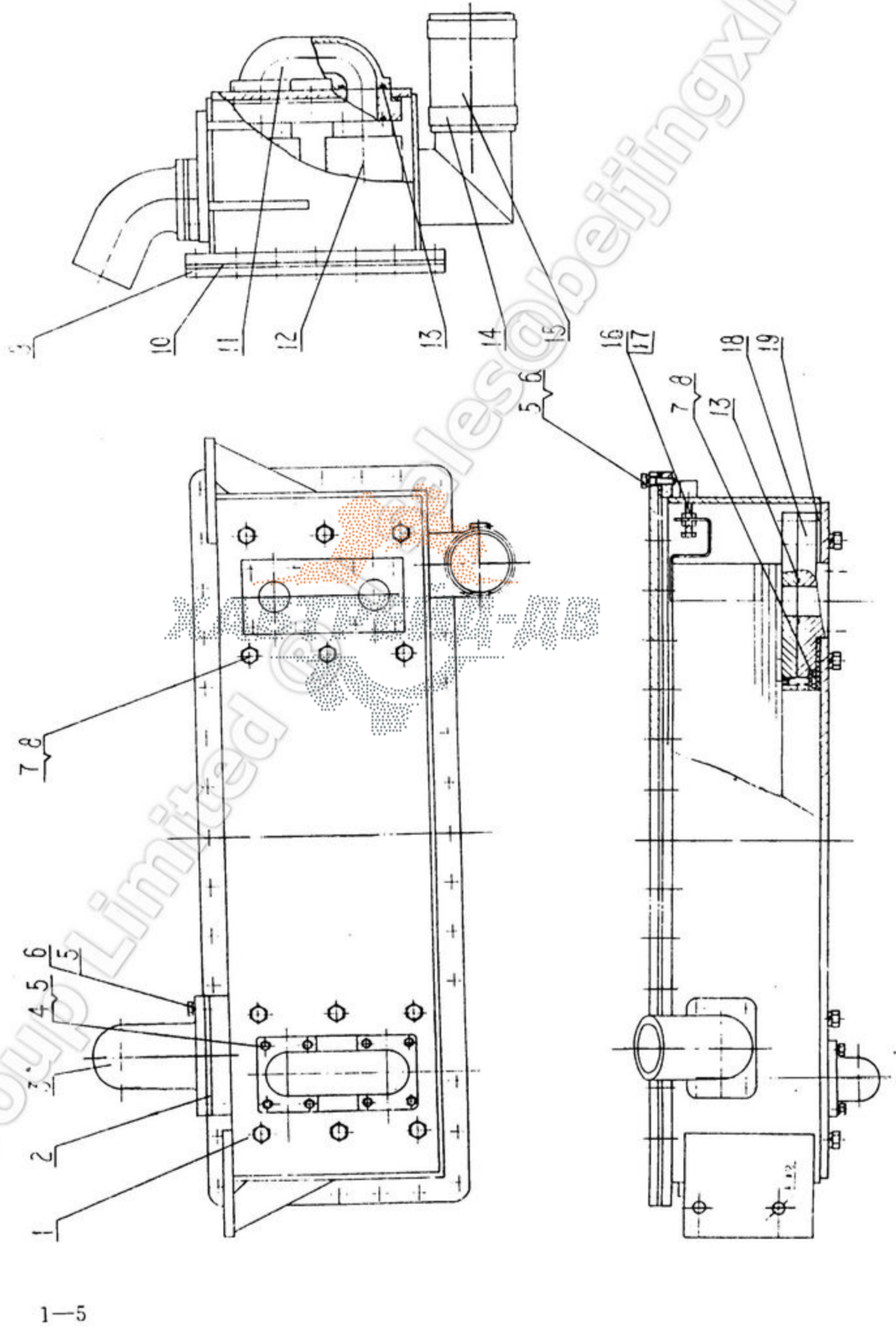

1T01107 油散热器组件 OIL COOLER ASSEM.

序号 NO.	代号 PART NO.	名 称 NAME	数量 Q' TY	备注 REMARK
1	1T01108	箱体焊接	1	
2	1T01129	橡胶垫(一)	1	
3	1T01120	进水管	1	
4	GB5783-86	螺栓 M8×20	8	
5	GB93-87	垫圈 8	52	
6	GB5783-86	螺栓 M8×25	44	
7	GB5783-86	螺栓 M10×25	28	
8	GB93-87	垫圈 10	28	
9	1T01122	盖板	1	
10	1T01123	密封垫	1	
11	1T01121	弯头	1	
12	1T01124	油冷器芯体	2	
13	GB3452·1-82	O 型圈 $\varnothing 40 \times 3.55$	6	
14	0T42102	喉箍 3X	2	
15	1T01130	胶管	1	
16	GB5783—86	螺栓 M8×45	4	
17	GB6170—86	螺母 M8—8	8	
18	1T01127	联接板	2	
19	1T01128	橡胶垫(三)	2	

1T01200

风扇护罩组件

FAN-GUARD GROUP

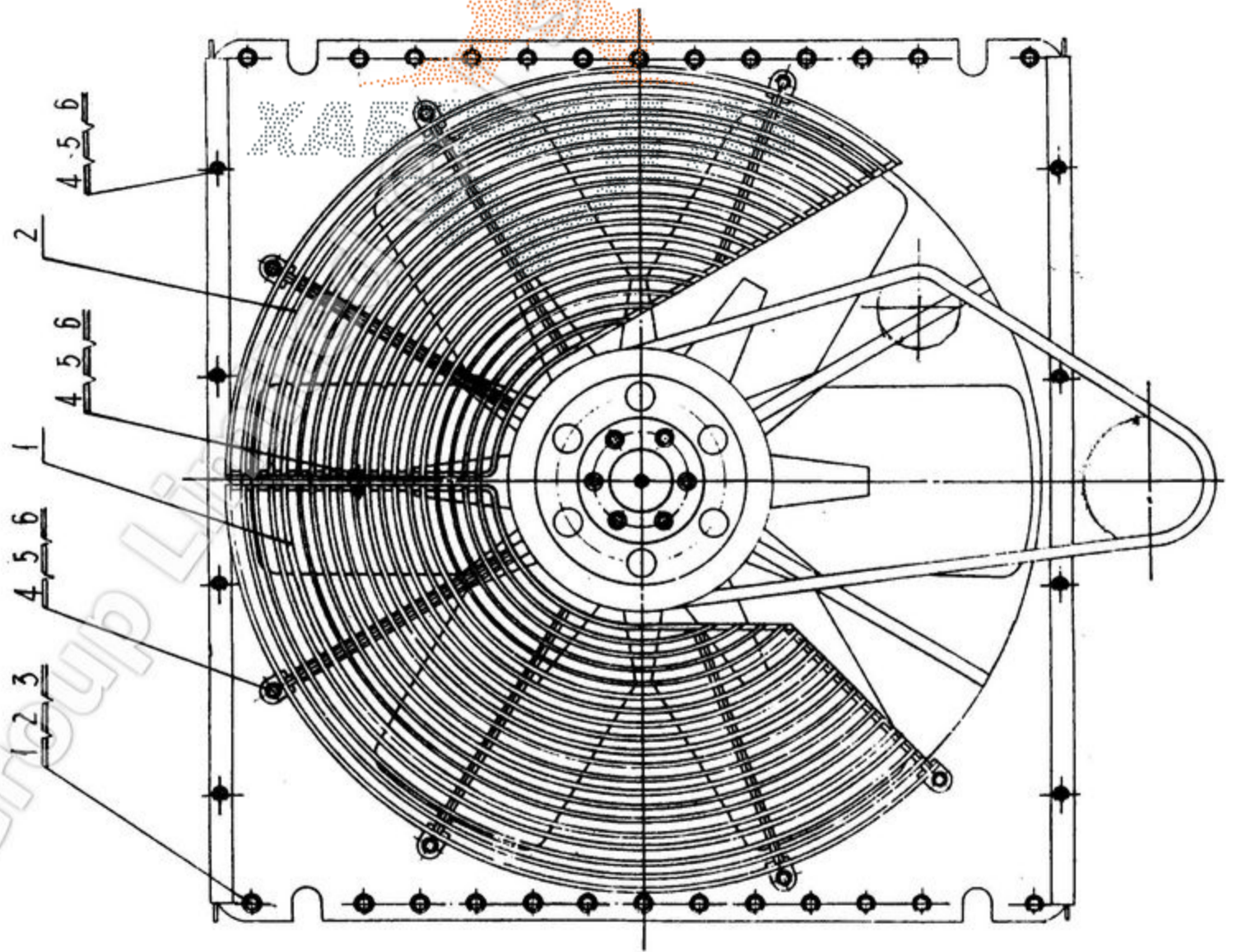
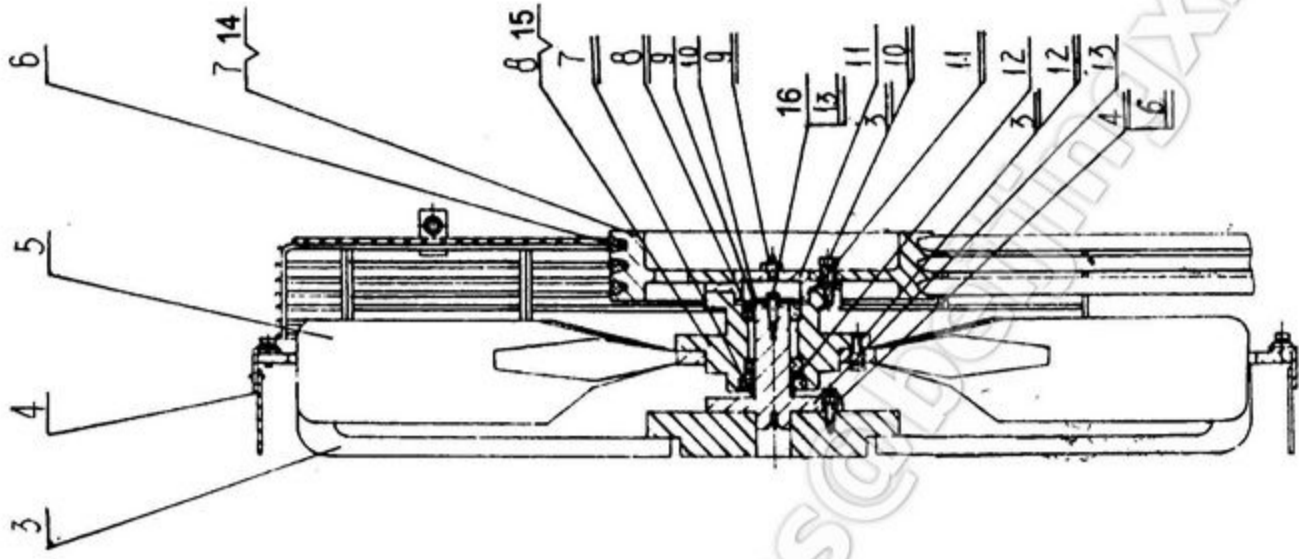

1-7

1T01200

风扇护罩组件

FAN-GUARD GROUP

序号 NO.	代号 PART NO.	名称 NAME	数量 Q'TY	备注 REMARK
1	1T01201	左护网	1	
2	1T01203	右护网	1	
3	1T01205	风扇皮带轮支架	1	
4	1T01212	封条	2	
5	1T01216	风扇	1	
6	1T01217	皮带(V-BELT)	3	
7	1T01218	皮带轮	1	
8	0T42216	轴承座	1	
9	0T42220	调整垫	1组	
10	0T42224	压板	1	
11	0T42217	堵盖	1	
12	0T42219	衬套	1	
13	0T42218	支承轴	1	
14	0T42225	调整垫	2	
15	0T03236	堵	1	
16	0T42214	螺栓	1	
1	GB5782-86	螺栓 M12×45	26	
2	GB97.1-85	垫圈 12	26	
3	GB93-87	垫圈 12	38	
4	GB5783-86	螺栓 M10×30	20	
5	GB97.1-85	垫圈 10	16	
6	GB93-87	垫圈 10	24	
7	HG4-692-67	油封 PG65×95×12	1	
8	GB297-84	轴承 7510E	2	
9	GB1152-79	油杯 M10×1	1	
10	GB5782-86	螺栓 M12×55	6	
11	GB3452.1-82	O型圈 95×3.55	1	
12	GB5783-86	螺栓 M12×40	6	
13	GB/T1230-91	垫圈 16	1	

1T01300

柴油机组件

DIESEL ENGIN GROUP

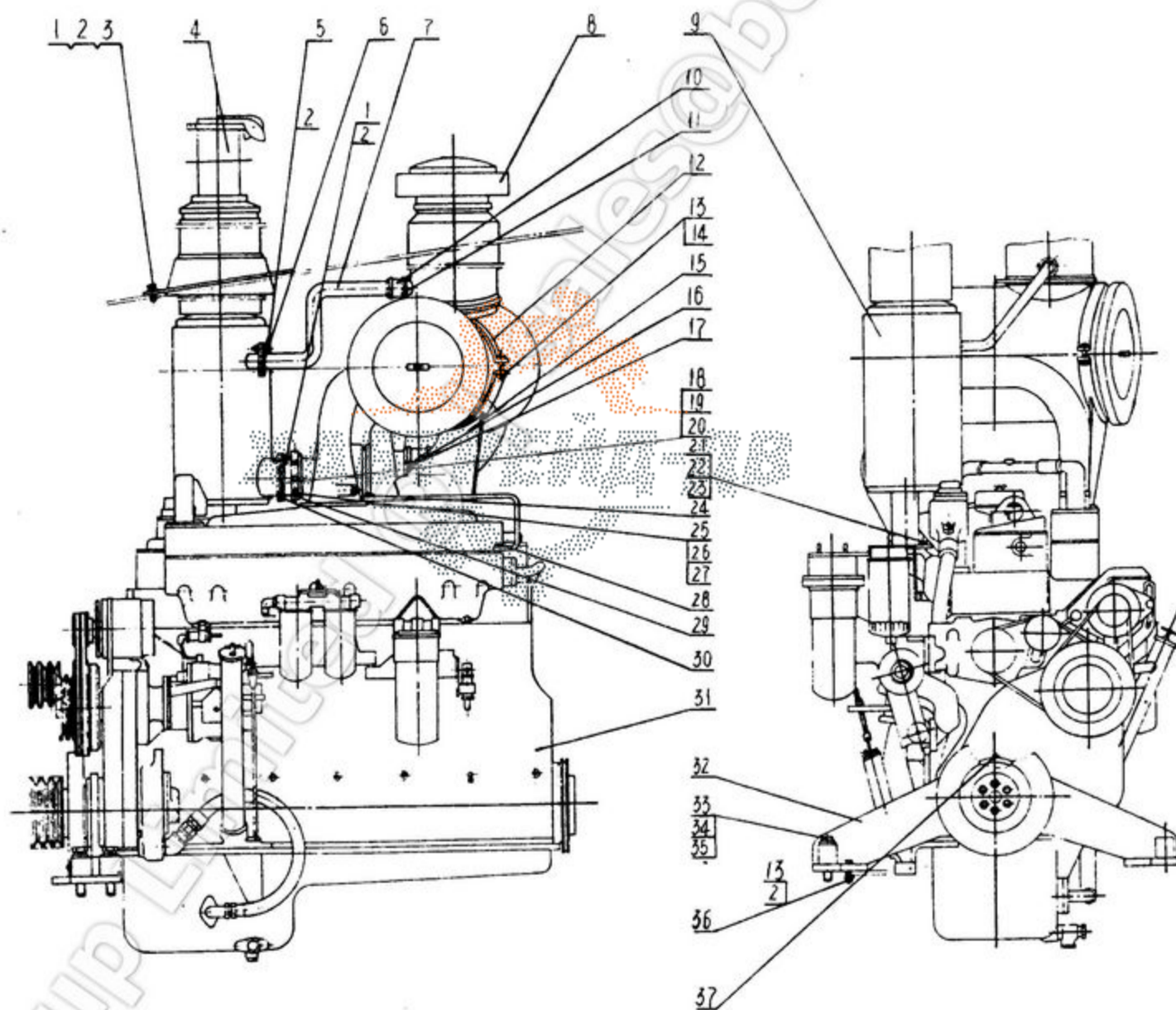

1T01300

柴油机组件

DIESEL ENGINE GROUP

序号 NO.	代号 PART NO.	名 称 NAME	数量 Q'TY	备注 REMARK
1	GB5783-86	螺栓 M10×30	BOLT M10×30	10
2	GB93-87	垫圈 10	WASHER 10	16
3	GB97.1-85	垫圈 10	WASHER 10	8
4	1T01301	排气管	EXHAUST PIPE ASS'Y	1
5	GB5783-86	螺栓 M10×25	BOLT M10×25	4
6	0T42012	纸垫	PAPER GASKET	1
7	1T01302	引射管	MAKE INJECT PIPE	1
8	1T01305	空滤器总成	AIR CLEANER ASS'Y	1
9	1T01309	消声器	MUFFLER	1
10	0T42013	胶管	HOSE	1
11	0T42016	喉箍 2X	CLAMP 2X	2
12	0T42027	箍带	CLAMP	1
13	GB6170-86	螺母 M10—8	NUT M10	6
14	GB5782—86	螺栓 M10×55	BOLT M10×55	2
15	1T01330	支座	SUPPORT	1
16	0T42014	胶管	HOSE	1
17	0T42015	喉管 $\varnothing 135 \sim \varnothing 165$	HOSE	2
18	0T42022	联接管	JOINT PIPE	1
19	0T42024	联接板	CONNECTING PLATE	1
20	0T42026	密封环	SEAL RING	1
21	GB5782-86	螺栓 M12×45	BOLT M12×45	4
22	GB6170-86	螺母 M12—8	NUT M12—8	4
23	GB93-87	垫圈 12	WASHR 12	4
24	1T01334	螺栓	BOLT	2
25	GB5782—86	螺栓 M8×85	BOLT M8×85	2

1T01300

柴油机组件

DIESEL ENGINE GROUP

序号 NO.	代号 PART NO.	名 称 NAME	数量 Q'TY	备注 REMARK
26	GB6170—86	螺母 M8—8	2	
27	GB93—87	垫圈 8	2	
28	1T01335	螺栓	2	
29	0T42025	卡箍	2	
30	0T42028	垫	1	
31	1T01318	柴油机 NTA855	1	
32	1T01319	前支承	1	
33	GB5782-86	螺栓 M24×100	4	
34	GB93-87	垫圈 24	4	
35	GB97.1-85	垫圈 24	4	
36	GB5782—86	螺栓 M10×45	4	
37	GB1152-89	油杯 M10×1	1	

1T01400 分 动 箱 FLYWHEEL HOUSING

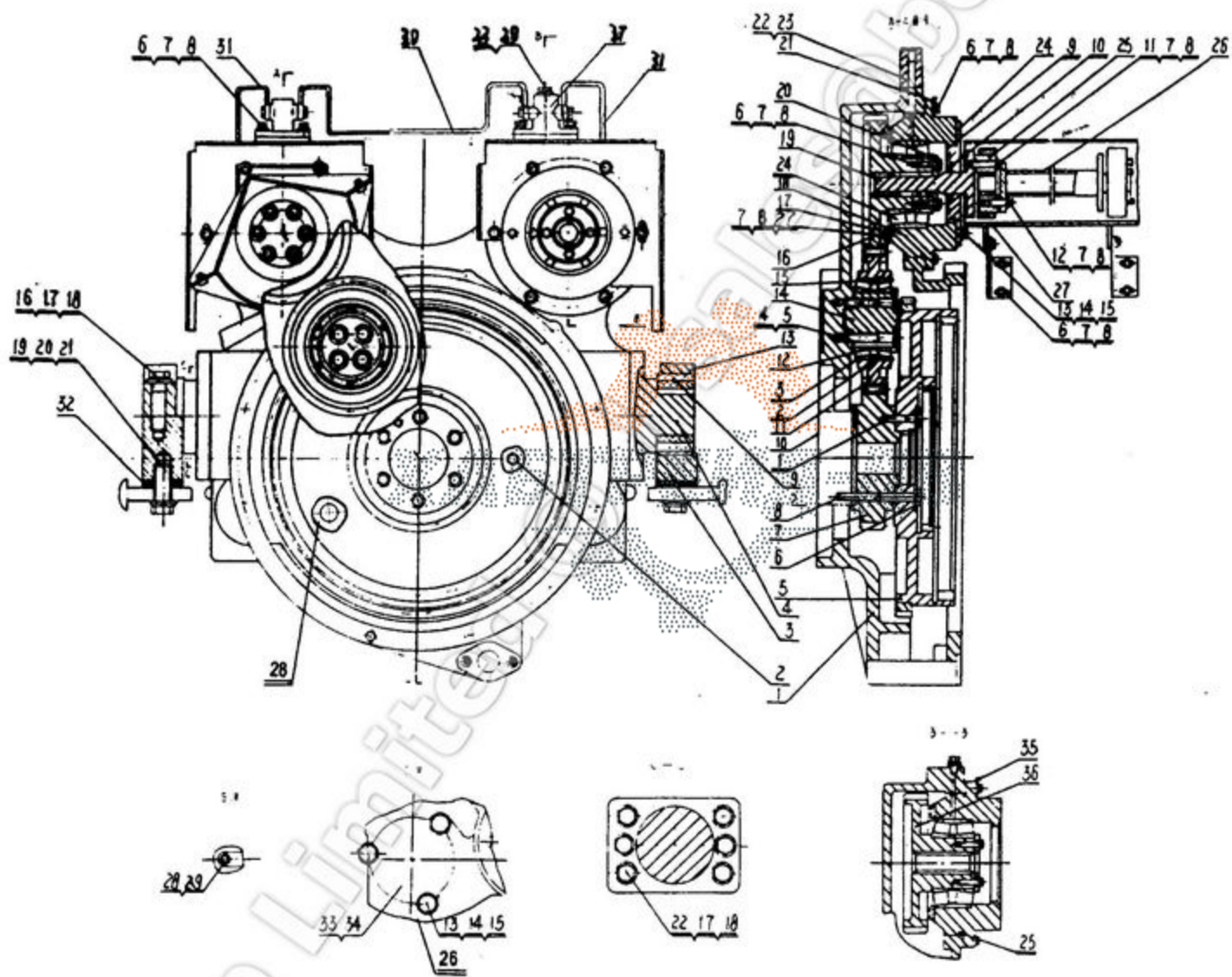

1T01400 分 动 箱 FLYWHEEL HOUSING

序号 NO.	代 号 PART NO.	名 称 NAME	数量 Q'TY	备 注 REMARK
1	1T01401	分动箱箱体	1	
2	1T01402	螺栓	8	
3	1T01403	下轴瓦	2	
4	1T01404	支承座	2	
5	1T01405	飞轮组件	1	
6	1T01408	止动垫片	1	
7	1T01409	主动轮	1	
8	1T01410	螺栓	6	
9	1T01411	缓冲套	2	
10	1T01415	纸垫	1	
11	1T01416	惰轮	2	
12	1T01417	隔垫	2	
13	1T01418	上轴瓦	2	
14	1T01419	惰轮轴	2	
15	1T01420	止动垫圈	2	
16	1T01421	泵齿轮	1	
17	1T01422	压圈	2	
18	1T01423	轴承座	2	
19	1T01424	花键轴	1	
20	1T01425	挡板	2	
21	1T01426	左护板	1	
22	1T01427	分油座	1	
23	1T01428	纸垫	1	
24	1T01429	密封环座	1	
25	0T01330	联接盘	2	

1T01400 分 动 箱 FLYWHEEL HOUSING

序号 NO.	代 号 PART NO.	名 称 NAME	数量 Q' TY	备 注 REMARK
26	1T01435	传动轴	1	
27	1T01438	传动轴保护罩	1	
28	0A09022	接头螺塞	6	
29	0A09017	密封垫	13	
30	0T01373	润滑管(三)	1	
31	0T01372	润滑管(二)	2	
32	1T01455	调整垫	2 组	
33	1T01456	堵盖	1	
34	1T01457	纸垫	1	
35	1T01458	右护板	1	
36	1T01459	装置泵齿轮	1	
37	1T01460	分油座	1	
1	GB119-86	园柱销 A10×30	1	
2	GB893.1-86	卡圈 Ø130	1	
3	GB297-84	轴承 2007117	4	
4	GB5783-86	螺栓 M12×85	8	
5	GB97.1-85	垫圈 12	8	
6	GB5783-86	螺栓 M10×35	34	
7	GB97.1-85	垫圈 10	52	
8	GB93-87	垫圈 10	52	
9	GB3452.1-82	O形密封圈 128×3.55	2	
10	HG4-692-67	油封 PG38×58×12	1	
11	GB5783-86	螺栓 M10×55	6	
12	GB5782-86	螺栓 M10×50	6	
13	GB5782-8.8	螺栓 M16×40	2	

1T01400

分 动 箱

FLYWHEEL HOUSING

序号 NO.	代 号 PART NO.	名 称 NAME	数量 Q'TY	备 注 REMARK
14	97.1-85	垫圈 16	5	
15	GB93-87	垫圈 16	5	
16	GB32-76	螺栓 M20×85	4	
17	GB93-87	垫圈 20	4	
18	GB97.1-85	垫圈 20	4	
19	GB32-76	螺栓 M24×80	4	
20	GB93-86	垫圈 24	4	
21	GB97.1-85	垫圈 24	4	
22	GB32-76	螺栓 M20×60	12	
23	GB5785-86	螺栓 M10×1×20	1	
24	GB299-86	轴承 97516E	2	
25	GB3452.1-82	O形密封圈 $\varnothing 212 \times 5.3$	2	
26	GB5783—86	螺栓 M16×35	3	
27	GB5783—86	螺栓 M10×25	6	
28	GB119—86	销 A12×55	2	

1T02000 变 矩 器 TORQUE CONVERTER

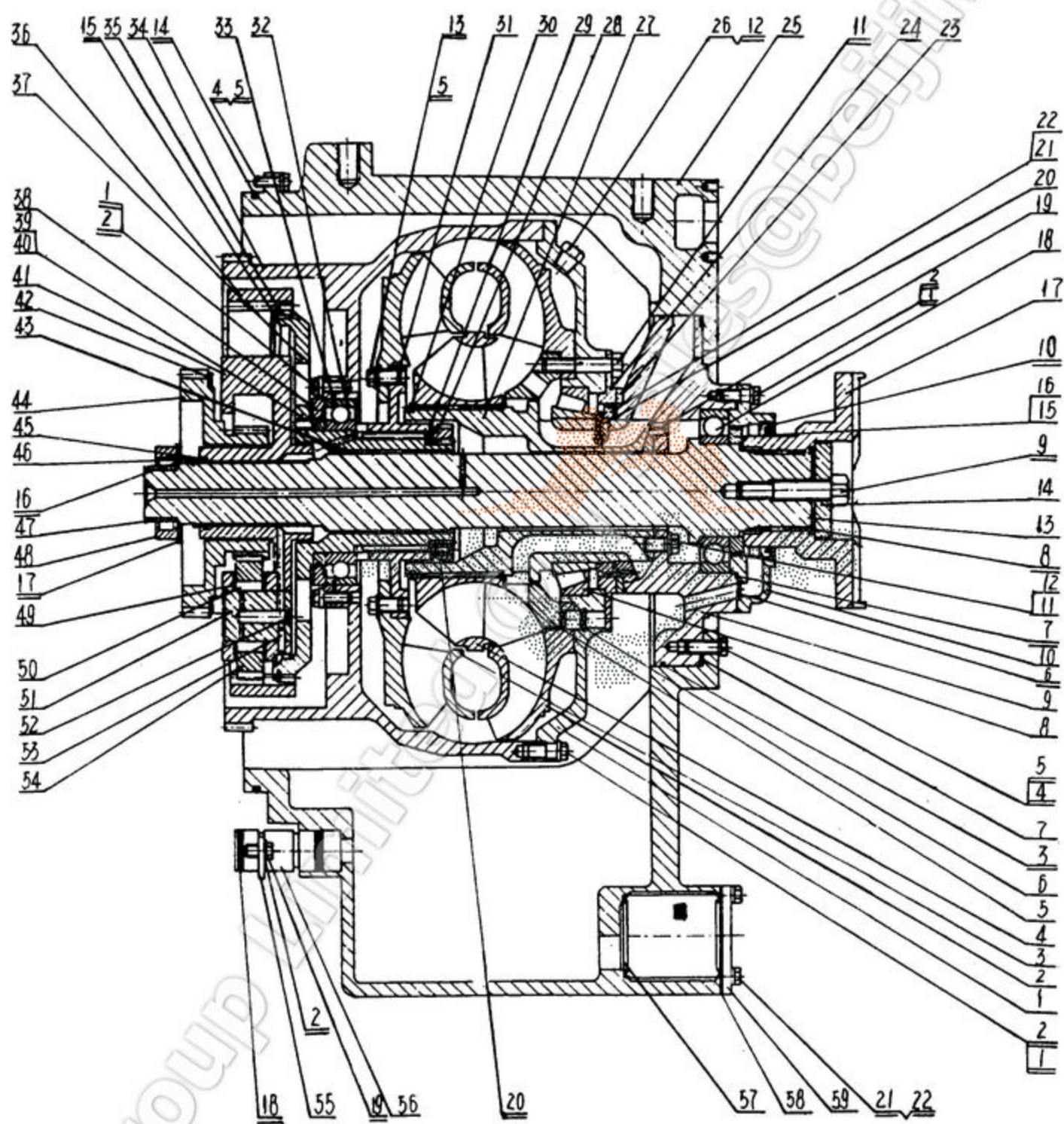

1T02000 变 矩 器 TORQUE CONVERTER

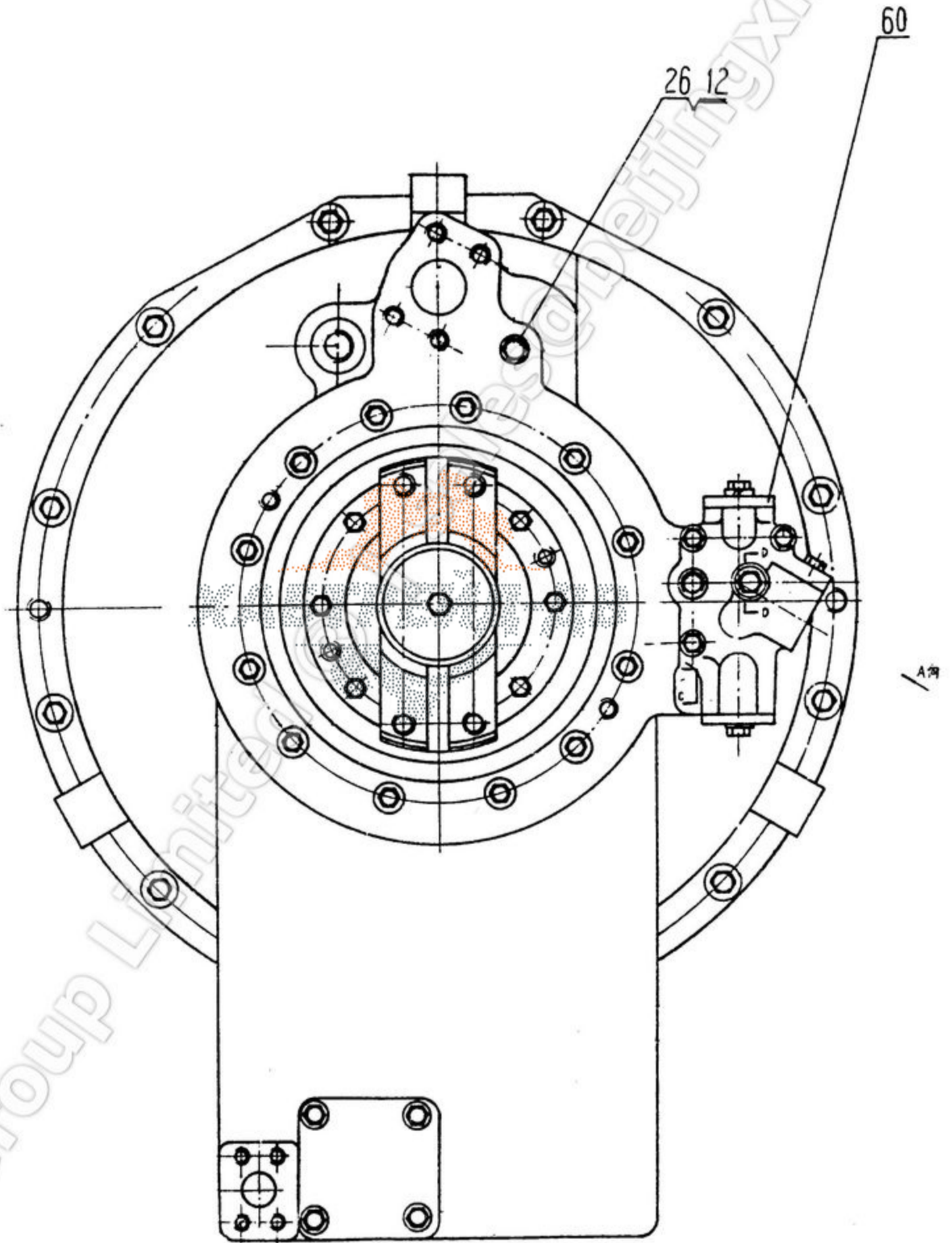

1T02000 变 矩 器 TORQUE CONVERTER

序号 NO.	代 号 PART NO.	名 称 NAME	数量 Q' TY	备 注 REMARK
1	1T02001	泵轮盖	1	
2	1T02002	泵轮	1	
3	1T02003	涡轮	1	
4	1T02004	导轮	1	
5	1T02005	泵轮压盘	1	
6	1B01349	定位销	2	
7	1T02006	O形圈 304.39×3.55	1	
8	1T02007	锥轴承	1	
9	1T02008	轴承座	1	
10	T02009	后轴承压盖	1	
11	1B12005	螺栓($\frac{1}{2}$ -13长28.58)	12	
12	1B01253	垫圈	12	
13	1T02010	输出轴	1	
14	1T02011	压盖	1	
15	1T02012	密封环座	1	
16	1B44034	密封环	1	
17	1T02013	联接盘	1	
18	1T02014	轴承	1	
19	1B01146	弹性销	5	
20	1B38416	弹性销	1	
21	1T02015	密封环座	1	
22	1T02016	密封环	1	
23	1T02017	隔环	1	
24	1T02018	压盖	1	
25	1T02019	壳体	1	
26	0T02048	塞堵	3	
27	1T02020	导轮座	1	
28	1T02021	圆螺母	1	
29	1T02022	止动垫片	1	
30	1T02023	弹性挡圈	2	
31	1T02024	涡轮联接盘	1	
32	1T02025	轴承	1	

1T02000 变 矩 器 TORQUE CONVERTER

序号 NO.	代 号 PART NO.	名 称 NAME	数量 Q'TY	备 注 REMARK
33	1T02026	轴承卡圈	1	
34	1T02027	泵轮壳	1	
35	1T02028	弹性卡环	1	
36	1T02029	齿圈	1	
37	1T02030	涡轮毂	1	
38	1T02031	前轴承压盖	1	
39	1T02032	密封环座	1	
40	1T02033	密封环	1	
41	1T02034	行星架	1	
42	1T02035	弹性挡圈	1	
43	1T02036	双金属轴套	2	
44	1T02037	太阳轮	1	
45	1T02038	卡环	1	
46	1T02039	隔环	1	
47	1T02040	轴承内套	1	
48	1T02041	轴承	1	
49	1T02042	行星轮端垫	6	
50	1T02043	滚针轴承	3	
51	1T02044	行星轮轴	3	
52	1B38220	塞堵	3	
53	0T03078	固定销	3	
54	1T02045	行星轮	3	
55	1T02046	卡板	1	
56	1T02047	导管	1	
57	0T03325	滤网总成	1	
58	0T03323	滤网盖垫	1	
59	0T03324	滤网盖板	1	
60	1T02048	出口压力阀	1	
1	GB5783-86	螺栓 M8×30	52	
2	GB97.1-85	垫圈 8	58	
3	GB3452.1-82	O形圈 315×5.3	1	
4	GB5783-86	螺栓 M12×35	24	

1T02000 变 矩 器 TORQUE CONVERTER

序号 NO.	代 号 PART NO.	名 称 NAME	数量 Q' TY	备 注 REMARK
5	GB97.1-85	垫圈 12 WASHER 12	48	
6	GB3452.1-82	O 形圈 17×2.65 O-SEAL RING17×2.65	1	
7	GB3452.1-82	O 形圈 150×5.3 O-SEAL RING150×5.3	1	
8	GB3452.1-82	O 形圈 67×5.3 O-SEAL RING 67×5.3	1	
9	GB5782-86	螺栓 M16×70 BOLT M16×70	1	
10	GB9877.3-88	唇式密封 Z100、130、12 LIP SEAL Z100、130、12	1	
11	GB5782-86	螺栓 M12×70 BOLYT M12×70	12	
12	GB3452.1-82	O 形圈 112×1.8 O-SEAL RING 112×1.8	3	
13	GB5783-86	螺栓 M12×30 BOLT M12×30	24	
14	GB3452.1-82	O 形圈 530×7.0 O-SEAL RING 530×7.0	1	
15	GB879-86	销 5×16 PIN 5×16	2	
16	GB894.1-86	挡圈 56 RETAINER56	1	
17	GB893.1-86	挡圈 85 RETAINER 56	1	
18	GB3452.1-82	O 形圈 32.5×3.55 O-SEAL RING 32.5×3.55	2	
19	GB5783-86	螺栓 M10×20 BOLT M10×20	2	
20	GB79-85	螺钉 M8×20 SCREW M8×20	1	
21	GB5783-86	螺栓 M10×25 BOLT M10×25	4	
22	GB97.1-87	垫圈 10 WASHER 10	4	

1T02048

出口压力阀

OUTLET PRESSURE VALVE

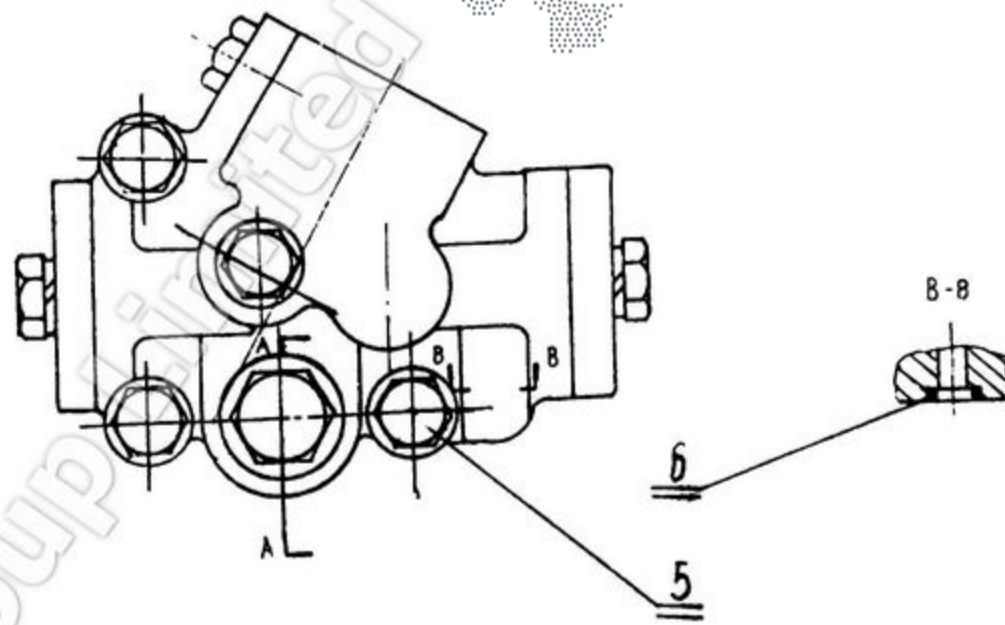
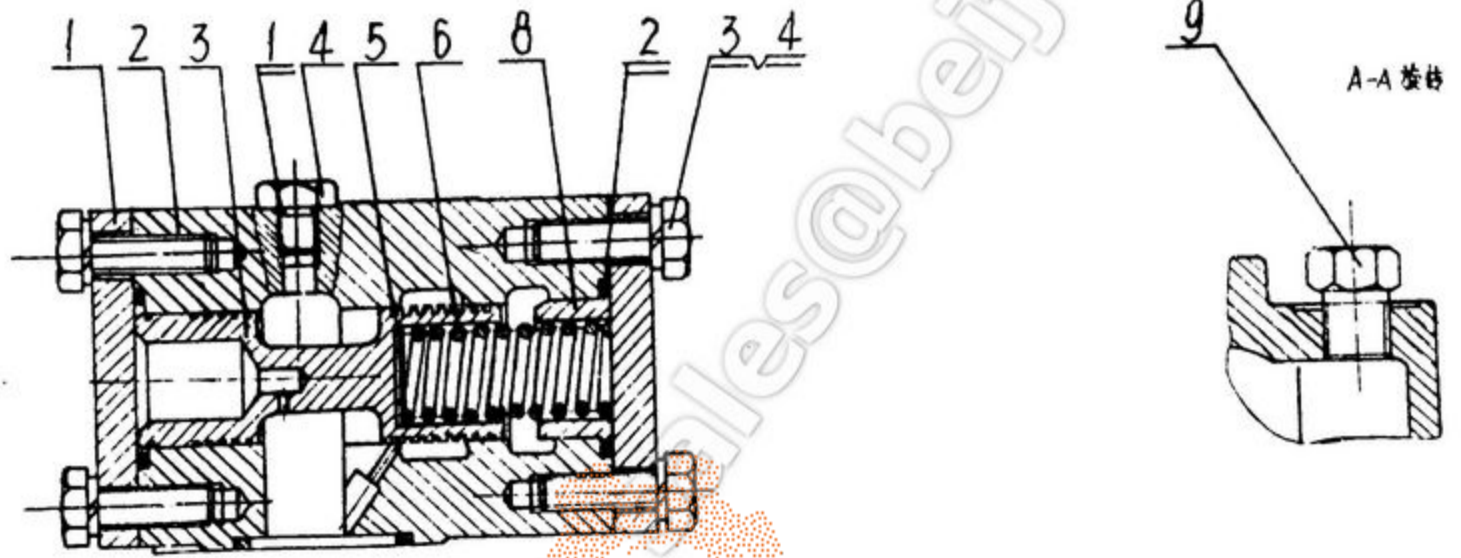

1T02048

出口压力阀

OUTLET PRESSURE VALVE

序号 NO.	代号 PART NO.	名称 NAME	数量 Q'TY	备注 REMARK
1	0T02045	腰形法兰	2	
2	0T02046	阀体	1	
3	0T02047	阀芯	1	
4	0T02048	油堵	2	
5	0T02049	调整垫	5	
6	1T02049	弹簧	1	
8	1T02050	导向套	1	
9	0T02053	油堵	1	
1	GB3452.1-82	O型密封圈 11.2×1.8	2	
2	GB3452.1-82	O型密封圈 36.5×3.55	3	
3	GB5783-86	螺栓 M10×30	4	
4	GB93-87	垫圈 10	4	
5	GB5782-86	螺栓 M10×75	3	
6	GB3452.1-82	O型密封圈 8×2.65	1	

1T03000

变速总成

TRANSMISSION ARRANGEMENT

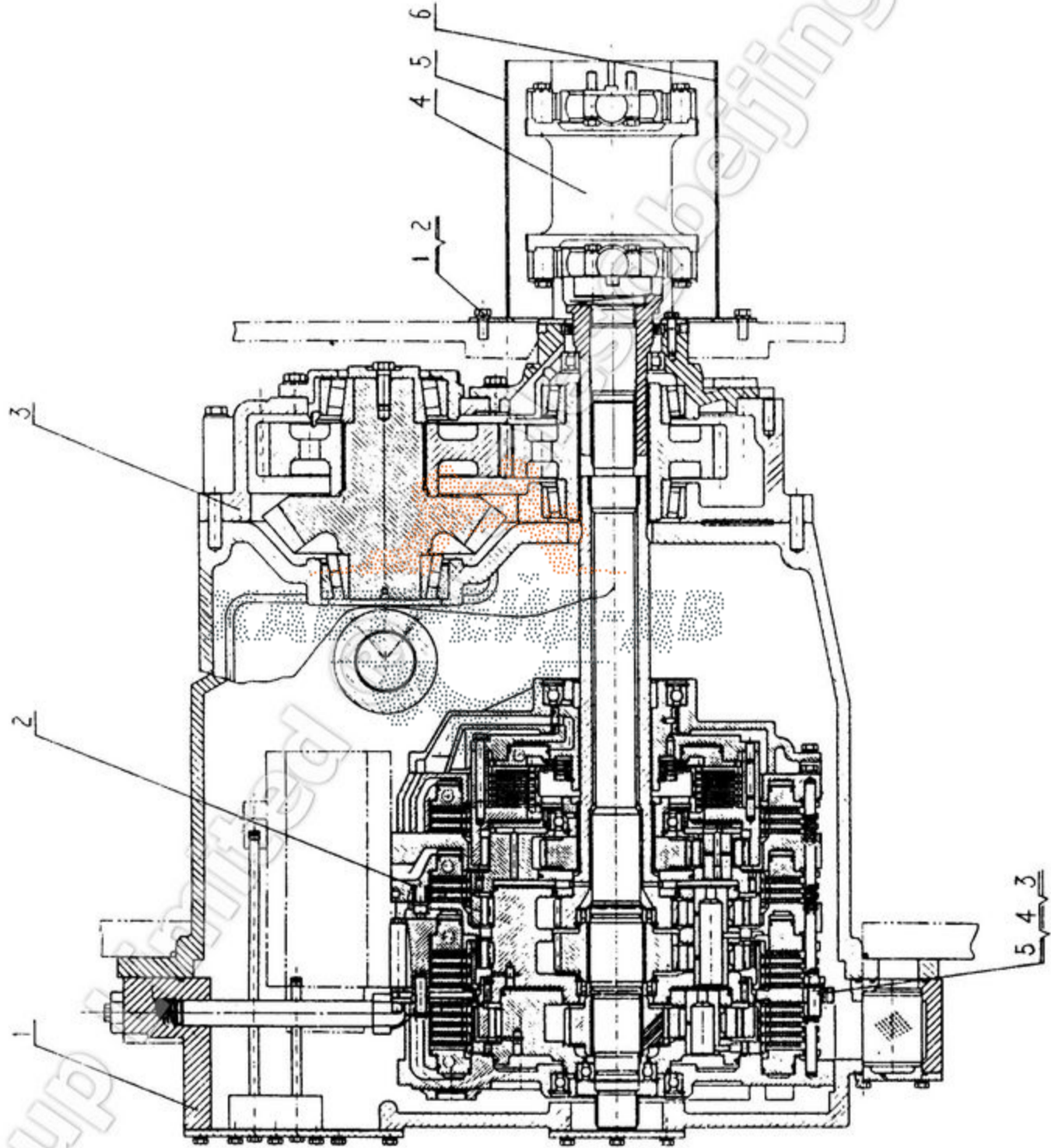

3-1

0T03000

变速总成

TRANSMISSION ARRANGEMENT

序号 NO.	代号 PART NO.	名称 NAME	数量 Q'TY	备注 REMARK
1	1T03300	后盖组件 REAR COVER GROUP	1	
2	1T03010	动力换挡变速箱 TRANSMISSION	1	
3	1T03200	中央传动 CENTRAL DRIVE	1	
4	1T03400	联轴器总成 UNIVERSAL JOINT ASSEM.	1	
5	1T03500	上保护罩 GUARD,UPPER	1	
6	1T03600	下保护罩 GUARD,LOWER	1	
1	GB5783-86	螺栓 M12×30 BOLT M12×30	6	
2	GB93-87	垫圈 12 WASHER 12	6	
3	GB5783-86	螺栓 M16×50 BOLT M16×50	15	
4	GB93-87	垫圈 16 WASHER 16	15	
5	GB97.1-85	垫圈 16 WASHER 16	15	

1T03010

动力换挡变速箱

TRANSMISSION

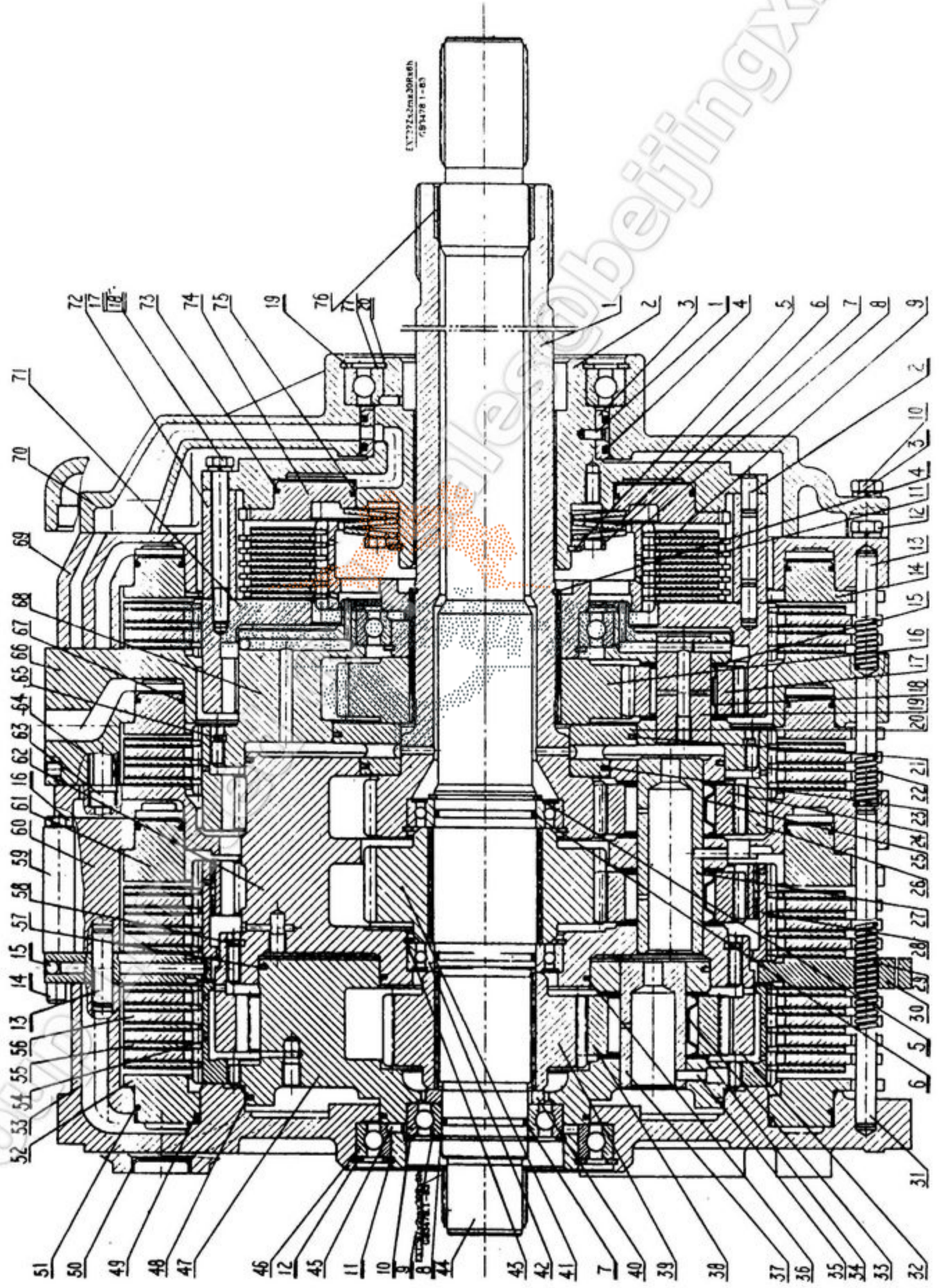

1T03010

动力换挡变速箱

TRANSMISSION

序号 NO.	代号 PART NO.	名称 NAME	数量 Q' TY	备注 REMARK
1	1T03011	输出轴 OUTPUT SHAFT	1	
2	1T03012	闭锁排活塞座 PISTON SEAT	1	
3	1T03013	压力油衬套 BUSH PRESSURE OIL	1	
4	1T03014	密封环 SEAL RING	2	
5	1T03015	卡环 CLAMP RING	1	
6	1T03016	蝶形弹簧 DISC SPRING	3	
7	1T03017	弹簧挡板 RETAINER PLATE, SPRING	1	
8	1T03018	闭锁齿轮 GEAR, PISTON	1	
9	1T03019	闭锁排摩擦片 FRICTION DISC, PISTON	6	
10	1T03020	高强度螺栓 BOLT	17	
11	1T03021	闭锁排对偶片 COUPLING DISC, PISTON	5	
12	1T03022	高强度螺栓 BOLT	2	
13	1T03023	定位销 DETENT PIN	6	
14	1T03024	三四排活塞 PISTON	2	
15	1T03025	垫 GASKET	6	
16	1T03026	四排太阳轮 SUN GEAR	1	
17	1T03027	四排行星轮 PLANETARY GEAR	3	
18	1T03028	滚针轴承 NEEDLE BEARING	3	
19	1T03029	四排行星轮轴 SHAFT, PLANETARY GEAR	3	
20	1T03030	油封座 OIL SEAL SEAT	1	
21	1T03031	密封环 SEAL RING	1	
22	1T03032	弹簧 SPRING	24	
23	1T03033	密封环 SEAL RING	1	
24	1T03034	二三排行星轮 PLANETARY GEAR	6	
25	1T03035	滚针轴承 NEEDLE BEARING	6	

1T03010

动力换挡变速箱

TRANSMISSION

序号 NO.	代号 PART NO.	名 称 NAME	数量 Q'TY	备注 REMARK
26	1T03036	三排齿圈	1	
27	1T03037	二、三排行星轮轴	3	
28	1T03038	二排齿圈	1	
29	1T03039	弹簧	12	
30	1T03040	隔板	1	
31	1T03041	定位销	6	
32	1T03042	一排齿圈	1	
33	1T03043	液针轴承	3	
34	1T03044	垫	18	
35	0T03078	定位销	9	
36	1T03045	密封环	2	
37	1T03046	一排行星轮轴	3	
38	1T03047	一排行星轮	3	
39	1T03048	一排太阳轮	1	
40	1T03049	隔环	1	
41	1T03050	二排太阳轮	1	
42	1T03051	轴承	2	
43	1T03052	卡环	2	
44	1T03053	输入轴	1	
45	0T03026	定位销	3	
46	1T03054	轴承	2	
47	1T03055	一排行星架	1	
48	1T03056	密封环	2	
49	1T03057	密封环	1	
50	1T03058	堵盖	1	

1T03010

动力换挡变速箱

TRANSMISSION

序号 NO.	代号 PART NO.	名称 NAME	数量 Q'TY	备注 REMARK
51	1T03059	密封环	4	
52	1T03060	一排活塞	1	
53	1T03061	一排活塞座	1	
54	1T03062	一排离合器齿圈	1	
55	1T03063	摩擦片	15	
56	1T03064	对偶片	11	
57	1T03065	密封环	1	
58	1T03066	卡环	1	
59	1T03067	导向套	2	
60	1T03068	二排活塞栓	1	
61	1T03069	二排活塞	1	
62	1T03070	二、三排行星架	1	
63	1T03071	螺钉	2	
64	0T03016	螺栓弹簧套	19	
65	1T03072	卡环	1	
66	1T03073	三排活塞座	1	
67	1T03074	密封环	3	
68	1T03075	四排行星架	1	
69	1T03076	四排活塞座	1	
70	1T03077	前盖	1	
71	1T03078	四排齿圈	1	
72	1T03079	闭锁齿圈	1	
73	1T03080	密封环	1	
74	1T03081	闭锁排活塞	1	
75	1T03082	密封环	1	

1T03010

动力换挡变速箱

TRANSMISSION

序号 NO.	代号 PART NO.	名称 NAME	数量 Q'TY	备注 REMARK
76	1T03083	双金属轴套	1	
77	1T03084	轴承	1	
1	GB879-86	销 6×15	1	
2	GB119-86	销 B10×25	4	
3	GB93-87	垫圈 12	19	
4	GB894.1-86	挡圈 90	1	
5	GB894.1-86	挡圈 65	1	
6	GB3452.1-86	O型密封圈 58×3.55	2	
7	GB3452.1-86	O型密封圈 47.5×3.55	1	
8	GB894.1-86	挡圈 55	1	
9	GB276-89	轴承 211	1	
10	GB893.2-86	挡圈 100	1	
11	GB894.1-86	挡圈 120	2	
12	GB893.2-86	挡圈 165	2	
13	GB119-86	销 B12×50	2	
14	GB119-86	销 B12×32	7	
15	GB308-76	钢球 Ø8	5	
16	GB5782-86	螺栓 M10×100-8.8	2	
17	GB5782-86	螺栓 M10×95-8.8	20	
18	GB93-87	垫圈 10	20	
19	GB893.2-86	挡圈 180	1	
20	GB894.1-86	挡圈 130	1	

1T03200

中央传动

CENTRAL DRIVE

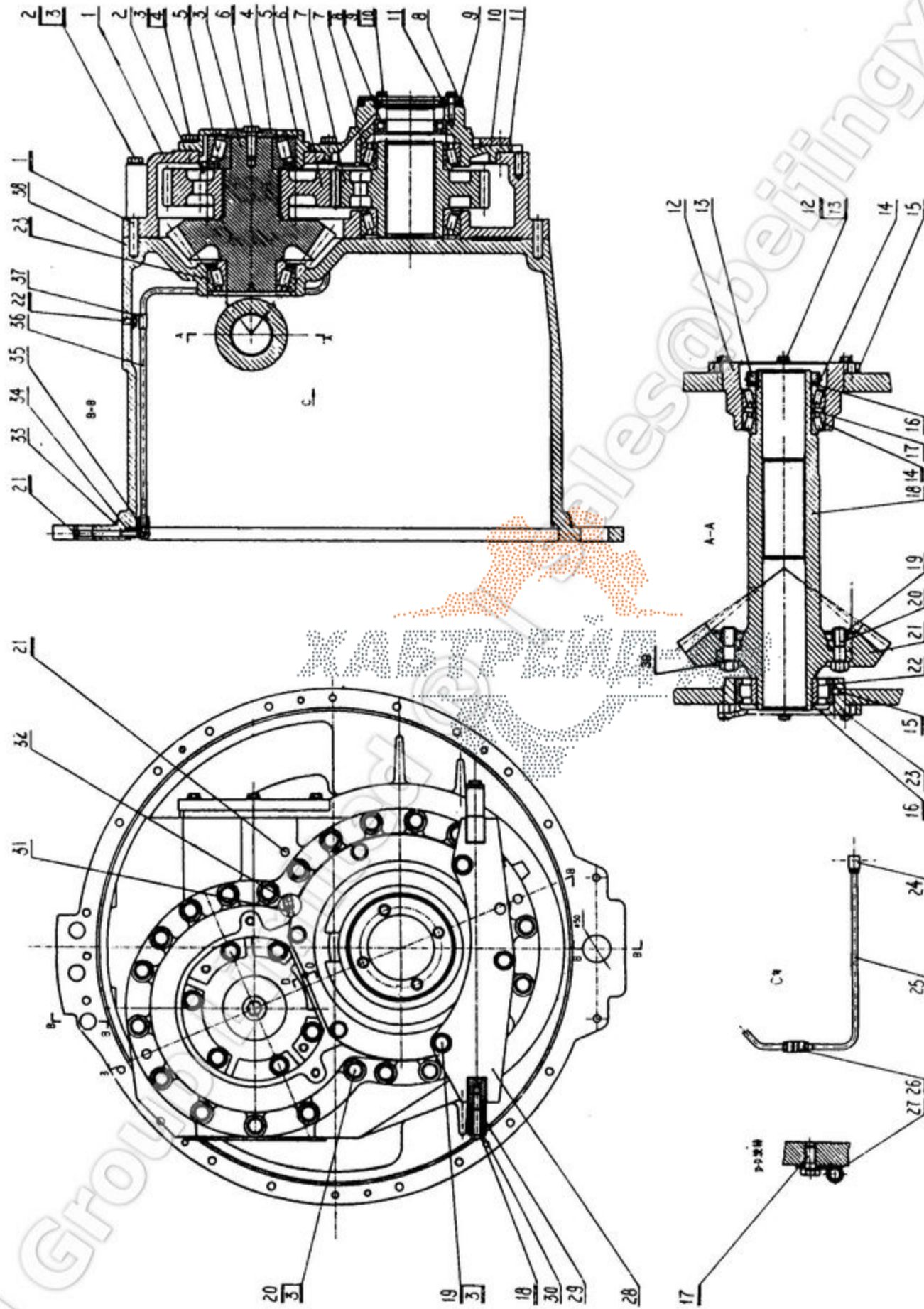

1T03200

中央传动

CENTRAL DRIVE

序号 NO.	代号 PART NO.	名称 NAME	数量 Q'TY	备注 REMARK
1	1T03201	小箱体	1	
2	1T03202	调整垫	1组	
3	1T03203	小伞齿轮	1	
4	1T03204	挡垫	1	
5	1T03205	轴承座	1	
6	1T03206	被动轮	1	
7	1T03207	主动轮	1	
8	1T03208	挡板	1	
9	1T03209	橡胶圈	1	
10	1T03210	轴承座	1	
11	1T03211	调整垫	1组	
12	1T03212	轴承座	1	
13	1T03213	螺母	1	
14	1T03214	防松垫	1	
15	1T03215	调整垫	1组	
16	1T03216	大垫圈	1	
17	1T03217	隔环	1	
18	1T03218	主传动轴	1	
19	0T03228	螺母	14	
20	0T03229	螺栓	14	
21	1T03220	大伞齿轮	1	
22	1T03221	轴承	1	
23	1T03222	轴承座	1	
24	1T03223	油管接头	1	
25	1T03224	油管组件(一)	1	

1T03200 中央传动 CENTRAL DRIVE

序号 NO.	代号 PART NO.	名称 NAME	数量 Q'TY	备注 REMARK
26	1T03226	油管接头	OIL PIPE JOINT	1
27	1T03227	管夹子	CLIP	1
28	1T03228	支撑架焊接	WELDED BRACKET	1
29	1T03231	滚轮	ROLLER	2
30	1T03232	压垫	GASKET	2
31	1T03233	油管组件(二)	OIL LINE(二)	1
32	1T03236	油管接头	OIL PIPE JOINT	1
33	1T03237	大O型圈	O-SEAL RING	1
34	1T03238	油管接头	OIL PIPE JOINT	1
35	0T03201	直角管接头	JOINT	1
36	1T03239	油管组件(三)	OIL LINE(三)	1
37	1T03241	管夹子	CLIP	1
38	1T03242	中央传动箱体	HOUSING	1
39	1T03243	防松垫	GASKET	7
1	GB119-86	销 B16×50	PIN B16×50	2
2	GB5782-86	螺栓 M16×160	BOLT M16×160	16
3	GB93-87	垫圈 16	WASHER 16	35
4	GB5783-86	螺栓 M16×40	BOLT M16×40	9
5	GB297-84	轴承 7615E	BEARING 7615E	1
6	GB5783-86	螺栓 M16×45	BOLT M16×45	1
7	GB297-84	轴承 3007124	BEARING 3007124	2
8	GB283-87	轴承 32117	BEARING 32117	1
9	GB5782-86	螺栓 M10×45	BOLT M10×45	4
10	GB93-87	垫圈 10	WASHER 10	4
11	HG4-692-67	骨架油封 PG100×130×12	OIL SEAL PG100×130×12	1

1T03200

中央传动

CENTRAL DRIVE

序号 NO.	代号 PART NO.	名称 NAME		数量 Q'TY	备注 REMARK
12	GB5782-86	螺栓 M12×45	BOLT M12×45	12	
13	GB93-87	垫圈 12	WASHER 12	12	
14	GB297-84	轴承 3007120	BEARING 30017120	2	
15	GB119-86	销 B10×20	PIN B10×20	1	
16	GB894.2-86	挡圈 100	RETAINER 100	1	
17	GB5783-86	螺栓 M8×18	BOLT M8×18	1	
18	GB5782-86	螺栓 M12×75	BOLT M12×75	2	
19	GB5782-86	螺栓 M16×55	BOLT M16×55	3	
20	GB5782-86	螺栓 M16×90	BOLT M16×90	7	
21	GB308-77	钢球 Ø15	STEEL BALL Ø15	2	
22	GB5783-86	螺栓 M10×20	BOLT M10×20	1	
23	GB297-84	轴承 3007218	BEARING 3007218	1	

1T03300 后盖组件 REAR COVER GROUP

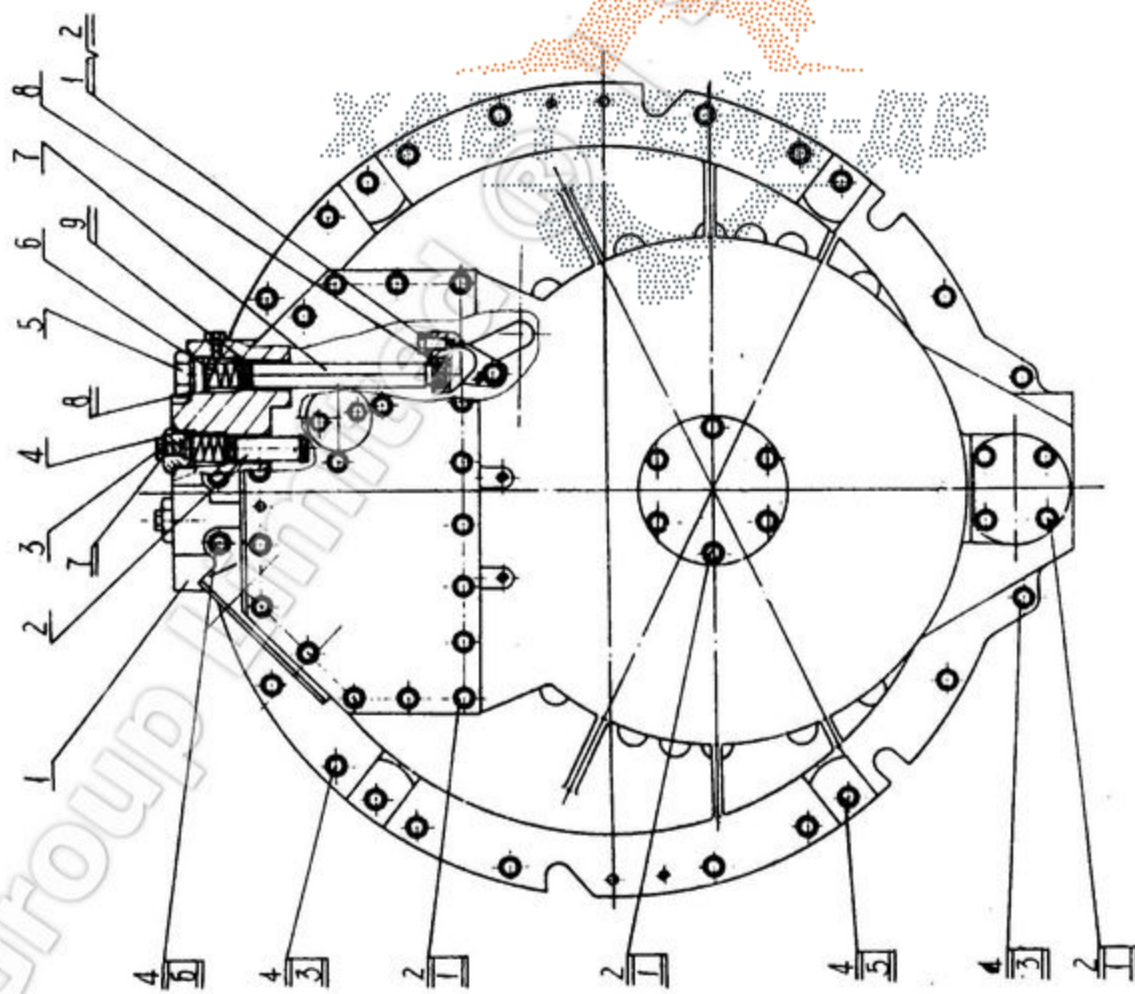
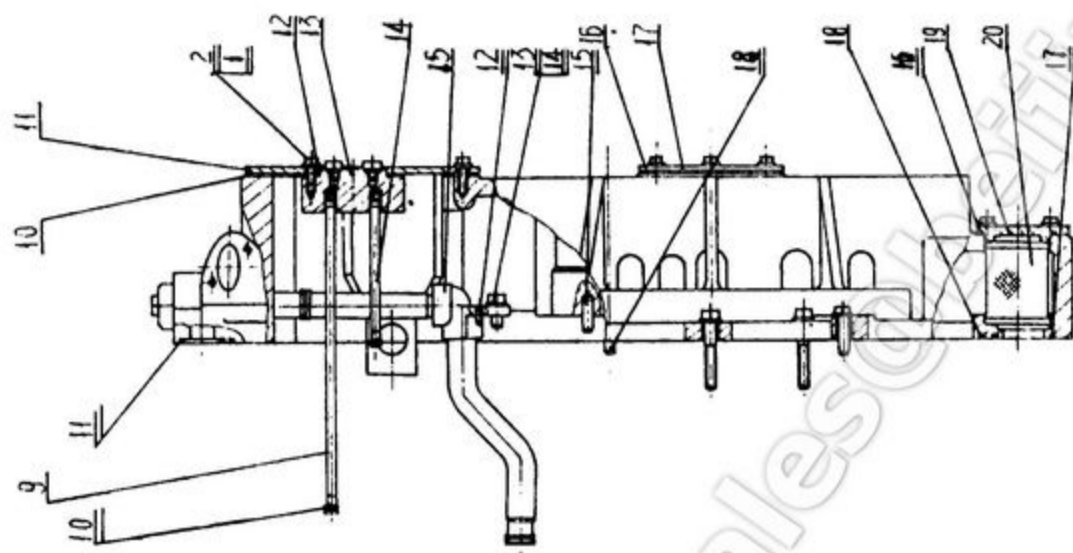

1T03300 后盖组件 REAR COVER GROUP

序号 NO.	代号 PART NO.	名 称 NAME	数量 Q'TY	备注 REMARK
1	1T03301	后盖体	1	
2	1T03302	短油管	2	
3	0T03303	小螺栓	5	
4	0T03304	短油管大螺栓	2	
5	0T03305	长油管大螺栓	1	
6	0T03306	弹簧	3	
7	1T03303	长油管	1	
8	0T03308	卡板	1	
9	1T03304	长测压管	1	
10	1T03306	后窗板垫	1	
11	1T03308	后窗板	1	
12	1T03310	测压管座垫	1	
		PIPE BRACKET		
13	1T03311	测压管座	1	
14	1T03312	短测压管	1	
15	1T03314	弯管总成	1	
16	0T03320	后盖垫	1	
17	0T03321	后盖	1	
18	1T03317	大O型圈	1	
19	1T03318	滤网盖板	1	
20	0T03325	滤网总成	1	
1	GB5783-86	螺栓 M10×25	34	
2	GB97.1-87	垫圈 10	34	
3	GB5782-86	螺栓 M12×70	16	
4	GB97.1-87	垫圈 12	23	
5	GB5783-86	螺栓 M12×45	4	
6	GB5782-86	螺栓 M12×120	3	
7	GB3452.1-82	O型密封圈 8.75×1.8	5	
8	GB3452.1-82	O型密封圈 38.1×2.65	3	

0T03300

后盖组件

REAR COVER GROUP

序号 NO.	代号 PART NO.	名 称 NAME	数量 Q'TY	备注 REMARK
9	GB3452.1-82	O 型密封圈 26.5×3.55	O-SEAL RING 26.5×3.55	7
10	GB3452.1-82	O 型密封圈 9×1.8	O-SEAL RING 9×1.8	4
11	GB3452.1-82	O 型密封圈 40×5.3	O-SEAL RING 40×5.3	3
12	GB119-86	销 A6×15	PIN A6×15	1
13	GB5783-86	螺栓 M12×25	BOLT M12×25	1
14	GB93-86	垫圈 12	WASHER 12	1
15	GB119-86	销 A12×35	PIN A12×35	1
16	GB3452.1-82	O 型密封圈 77.5×3.55	O-SEAL RING 77.5×3.55	1
17	GB3452.1-82	O 型圈 60×5.3	O-SEAL RING 60×5.3	1
18	GB119-86	销 B12×65	PIN B12×65	2

1T03400

联轴器总成

UNIVERSAL JOINT ASSEMBLY

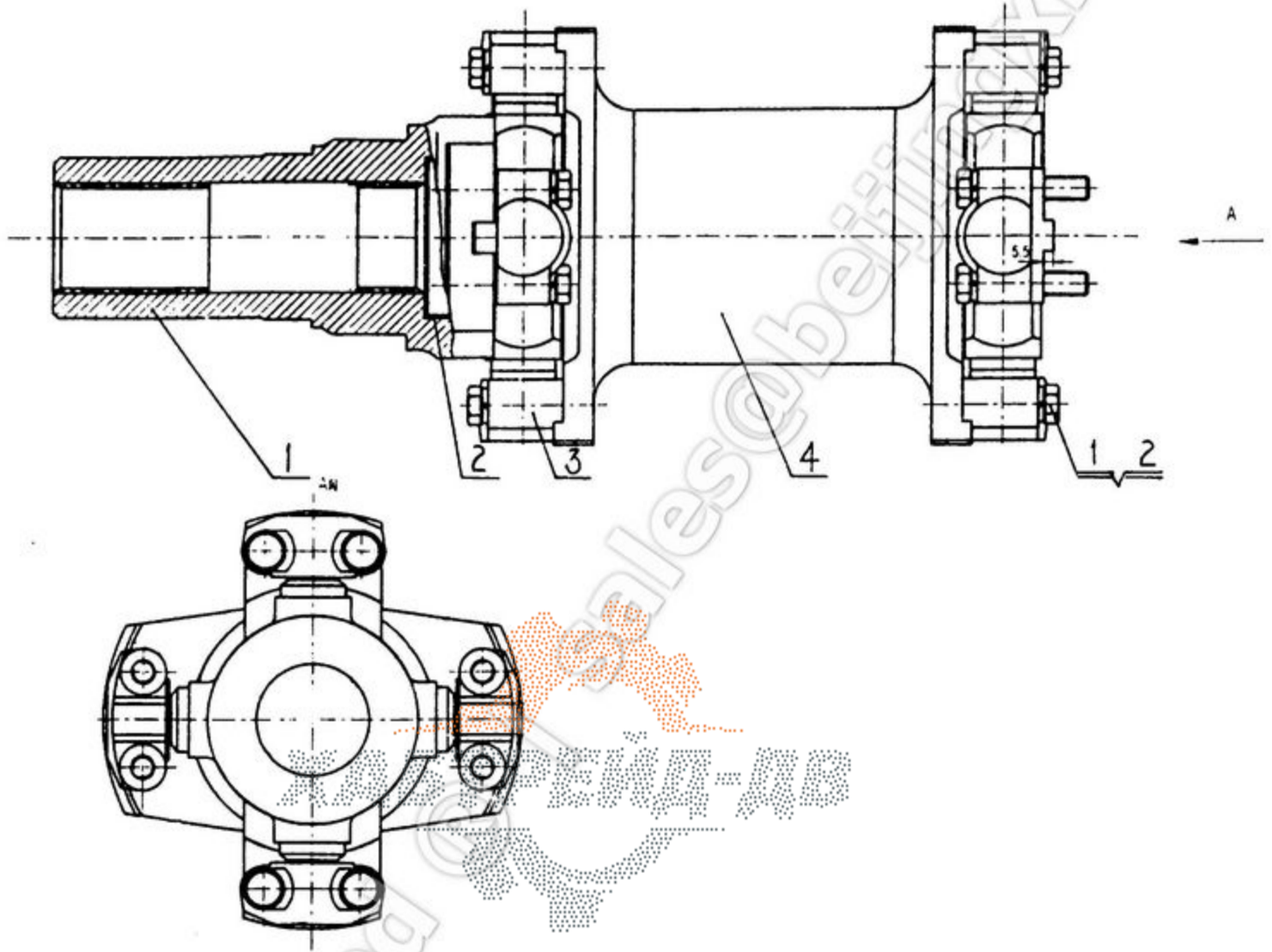

序号 NO.	代号 PART NO.	名 称 NAME	数量 Q'TY	备注 REMARK
1	1T03401	法兰盘 FLANGE	1	
2	1T03402	堵盖 PLUG CAP	1	
3	1T03403	T320 万向节 十字轴总成 T320 COUPLER SHAFT ASSEM.	2	
4	1T03404	连接轴 COUPLING SHAFT	1	
1	GB5782-86	螺栓 M12×60 BOLT M12×60	16	
2	GB93—87	垫圈 12 WASHER 12	16	

1T04000 转向与制动离合器 STEERING & BRAKE CLUTCH

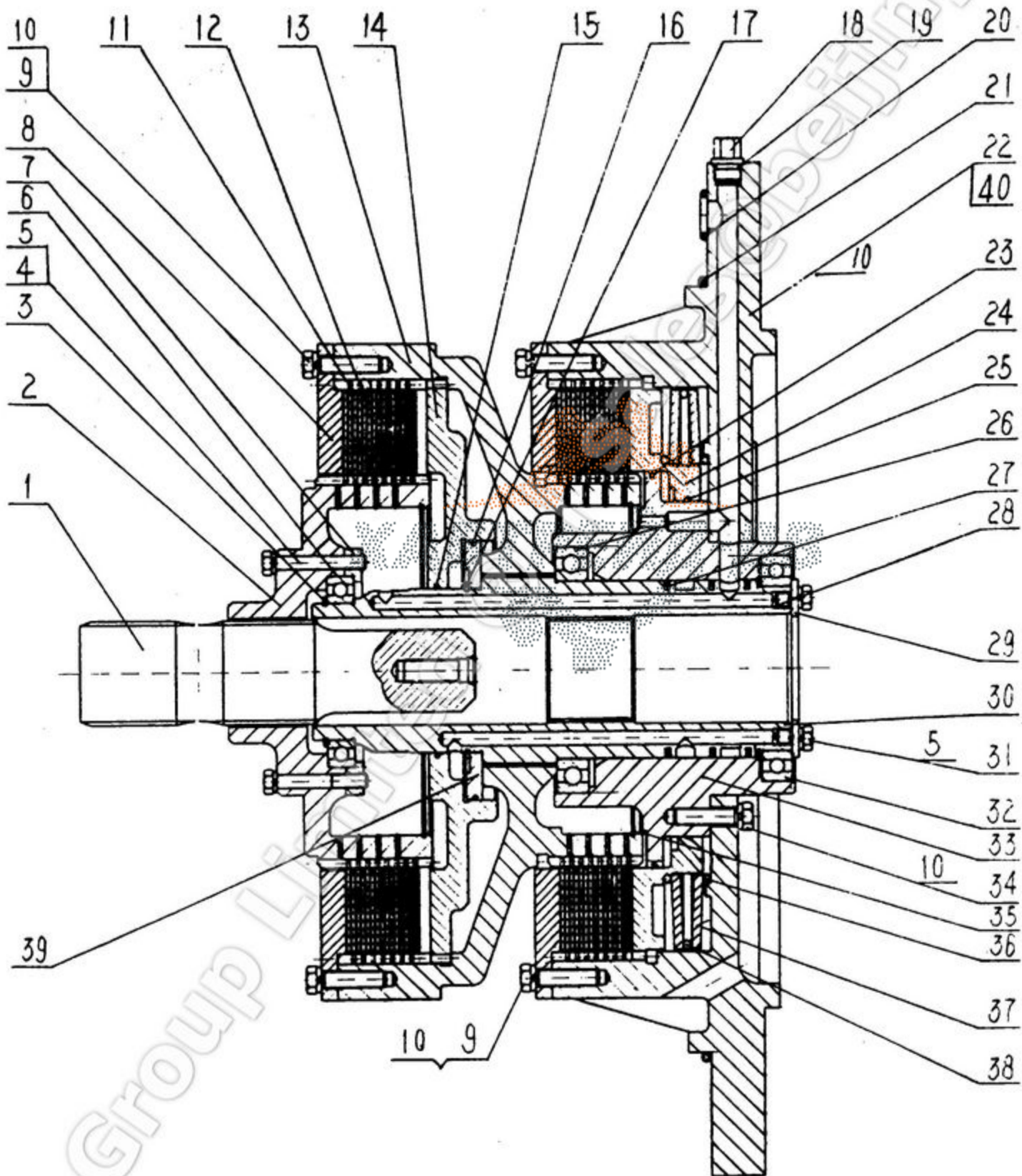

1T04000 转向与制动离合器 STEERING & BRAKE CLUTCH

序号 NO.	代号 PART NO.	名 称 NAME	数量 Q'TY	备注 REMARK
1	1T04029	输入轴	1	
2	1T04002	主动毂	1	
3	GB894.1-86	挡圈 100	1	
4	GB5782—86	螺栓 M10×70	4	
5	GB93—87	垫圈 10	8	
6	GB276—89	轴承 1000920	1	
7	1T04003	轴承挡环	1	
8	1T04004	压盘	2	
9	GB5783-86	螺栓 M12×45	24	
10	GB97.1—85	垫圈 12-200HV	38	
11	1T04005	外齿片	14	
12	1T04025	内齿摩擦片	16	
13	1T04006	从动毂	1	
14	1T04007	转向活塞	1	
15	0T04008	密封圈	1	
16	0T04009	密封圈	1	
17	GB894.1-86	挡圈 120	1	
18	0T04018	油塞	3	
19	GB3452.1-92	O形圈 15×2.65	5	
20	GB3452.1-92	O形圈 33.5×5.3	3	
21	GB3452.1-92	O形圈 560×7	1	
22	1T04028	制动毂	1	
23	0T04022	密封圈	1	
24	1T04012	制动活塞	1	
25	1T04018	密封圈	1	

1T04000 转向与制动离合器 STEERING & BRAKE CLUTCH

序号 NO.	代号 PART NO.	名 称 NAME	数量 Q'TY	备注 REMARK
26	GB276—89	轴承 1000926	1	
27	0T04027	密封环	3	
28	0T04025	油堵	2	
29	0T04026	挡环	1	
30	1T04026	输出轴	1	
31	GB5783-86	螺栓 M10×30	4	
32	GB276-89	轴承 1000924	1	
33	1T04031	轴承座	1	
34	GB5783—86	螺栓 M12×50	11	
35	1T04019	挡油环	2	
36	1T04016	钢丝圈	2	
37	1T04015	碟形弹簧	2	
38	1T04014	钢丝圈	1	
39	0T04024	挡盘	1	
40	GB5782—86	螺栓 M12×65	3	

1T05000 终传动 FINAL DRIVE

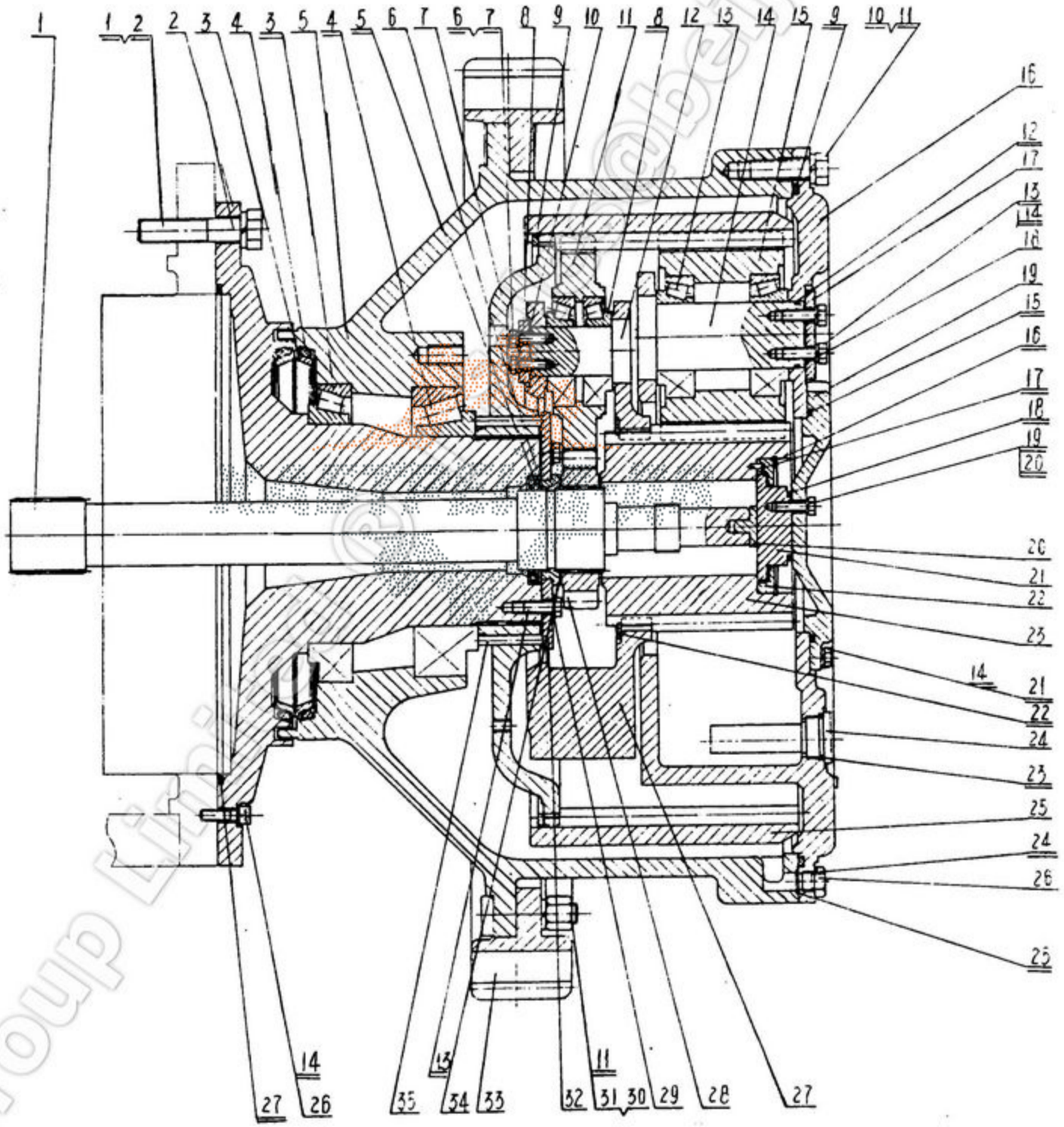

1T05000 终 传 动 FINAL DRIVE

序号 NO.	代 号 PART NO.	名 称 NAME	数量 Q' TY	备注 REMARK
1	1T05001	终传动轴	1	
2	1T05002	支承盘	1	
3	0A21038	大油封环 \varnothing 370	2	
4	0A21037	大密封圈	2	
5	1T05005	链轮毂	1	
6	1T05006	调整垫	1 组	
7	1T05007	联接盘	1	
8	1T05008	小轴盖	3	
9	1T05009	挡圈	1	
10	0T05017	调整垫	3 组	
11	1T05010	前排行星轮	3	
12	1T05011	前排行星轮轴	3	
13	1B01283	圆锥滚子轴承	6	7K0394
13	1B01257	轴承外壳	6	6H3588
14	1T05012	后排行星轮轴	3	
15	1T05013	后排行星轮	3	
16	1T05014	后排行星架	1	
17	1T05015	大轴盖	3	
18	1T05016	调整垫	1	
19	1T05017	后盖	1	
20	0T05001	轴端垫	1	
21	1T05018	定位座	1	
22	1T05019	压环	1	
23	1T05020	后排太阳轮	1	
24	0T05022	加油堵	1	
25	1T05021	齿圈	1	
26	0T05028	放油螺堵	1	
27	1T05022	前排行星架	1	
28	1T05023	前排太阳轮	1	
29	1T05024	止动垫圈	6	
30	1T05025	螺栓	25	
31	0T05032	螺母	25	
32	1T05026	压板	1	

1T05000 终 传 动 FINAL DRIVE

序号 NO.	代 号 PART NO.	名 称 NAME	数量 Q'TY	备注 REMARK
33	1T05027	链齿	5	
34	1T05028	端垫	1	
35	1T05029	园柱销	12	
1	GB5782-86	螺栓 M24×110-10.9	30	
2	GB93-87	垫圈 24	30	
3	GB297-84	轴承 2007944E	1	
4	GB297-84	轴承 2007138E	1	
5	GB9877.3-88	油封 80×110×10	1	
6	GB5783-86	螺栓 M10×25	6	
7	GB97.1-85	垫圈 10	6	
8	GB297-84	轴承 7310E	6	
9	GB3452.1-82	O 形圈 670×7	1	
10	GB5783-86	螺栓 M20×65-10.9	35	
11	GB93-87	垫圈 20	60	
12	GB3452.1-82	O 形圈 60×3.55	3	
13	GB5783-86	螺栓 M12×30-10.9	18	
14	GB93-87	垫圈 12	12	
15	GB3452.1-82	O 形圈 224×5.3	1	
16	GB893.1-86	挡圈 135	1	
17	GB119-86	销 D5×12	1	
18	GB3452.1-82	O 形圈 60×5.3	1	
19	GB5783-86	螺栓 M10×35	3	
20	GB93-87	垫圈	3	
21	GB5783-86	螺栓 M12×30	3	
22	GB894.1-86	挡圈 195	1	
23	GB3452.1-82	O 形圈 38.7×3.55	1	
24	GB3452.1-82	O 形圈 17×2.65	1	
25	GB3452.1-82	O 形圈 20×2.65	1	
26	GB70-85	螺钉 M12×40	3	
27	GB3452.1-82	O 形圈 500×7	1	

1T06000 顶罩前保护板
 TOP COVER—FRONT GUARD

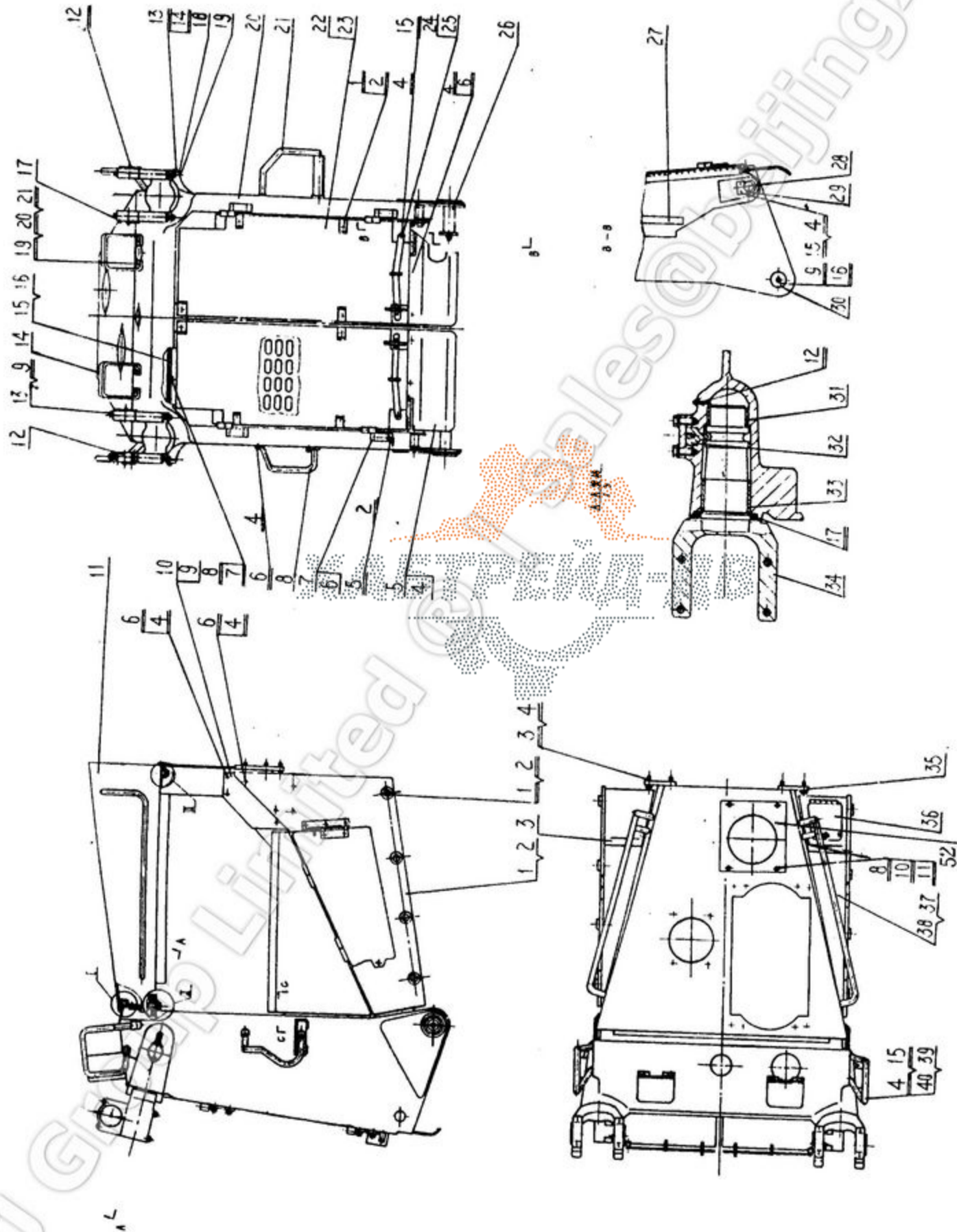

1T06000 顶罩前保护板
 TOP COVER—FRONT GUARD

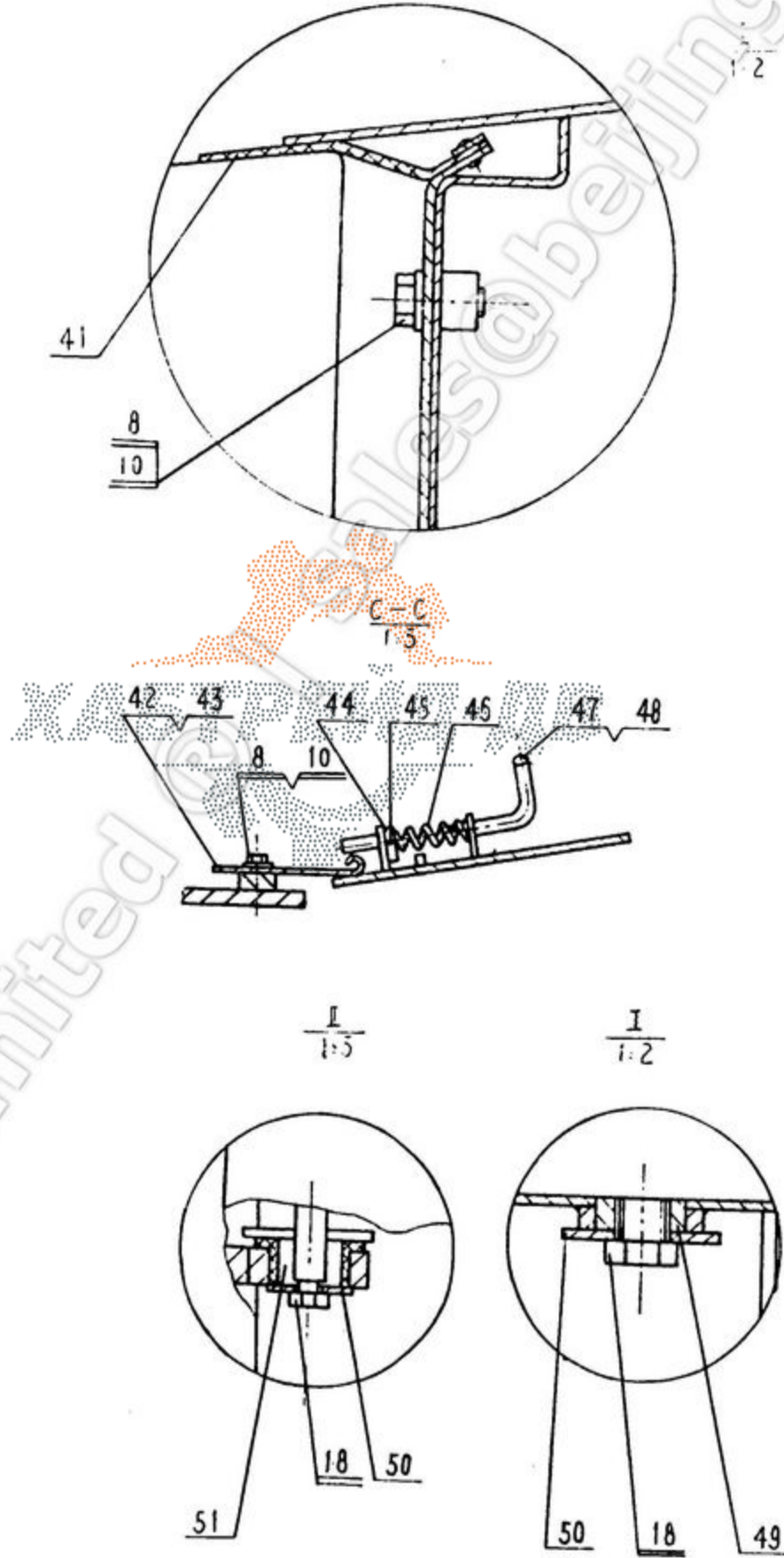

1T06000 顶罩前保护板
TOP COVER—FRONT GUARD

序号 NO.	代 号 PART NO.	名 称 NAME	数量 Q'TY	备注 REMARK
1	1T06030	左侧挡板组件 PLATE GROUP,LEFT	1	
2	1T06048	右侧挡板组件 PLATE GROUP,RIGHT	1	
3	1T06053	右小护板组件 SMALL GUARD PLATES,RIGHT	1	
4	1T06001	左护板 LEFT GUARD PLATE	1	
5	1T06002	右护板 RIGHT GUARD PLATE	1	
6	1T06056	左铲接轴 JOINT SHAFT,LEFT	2	
7	1T06059	右铰接轴 JOINT SHAFT,RIGHT	2	
8	1T06060	把手组件 HANDLE GROUP	1	
9	1T06003	左斜拉板 PLATE	1	
10	1T06004	右斜拉板 PLATE	1	
11	1T06063	大顶罩 TOP COVER	1	
12	1T06005	套 BUSH	4	
13	1T06006	螺栓 BOLT	8	
14	0T21015	灯罩 LAMP HOUSING	2	
15	1T06090	左挡板组件 RETAINER PLATE GROUP,LEFT	1	
16	1T06094	右挡板组件 RETAINER PLATE GROUP,RIGHT	1	
17	1T06096	油缸座 CYLINDER BRACKET	4	
18	1T06008	压盖 PRESSURE COVER	2	
19	1T06009	垫 GASKET	2	
20	1T06099	前保护板焊接 GUARD WELD	1	
21	0T06057	脚蹬组件 PEDAL	1	
22	1T06125	左散热门组件 COKLER DOOR GROUP,LEFT	1	
23	1T06144	右散热门组件 CODLER DOOR GROUP,RIGHT	1	
24	1T06145	左挡板 LEFT RETAIN PLATE	1	
25	1T06146	右挡板 RIGHT RETAIN PLATE	1	
26	1T06010	后销 REAR PIN	2	
27	1T06011	密封条 SEAL STREP	2	
28	1T06012	前销 FRONT PIN	2	
29	1T06013	卡板 PLATE	2	
30	1T06014	压板 PRESSURE PLATE	4	
31	1T06015	小衬套 BUSH	2	
32	1T06016	定位销 PIN,DETENT	2	

1T06000 顶罩前保护板
TOP COVER—FRONT GUARD

序号 NO.	代 号 PART NO.	名 称 NAME	数量 Q'TY	备注 REMARK
33	1T06017	大衬套	BUSH	2
34	1T06018	叉头	YOKE	2
35	1T06149	支撑板组件	SUPPORT PLATE GROUP	1
36	1T06158	左小门组件	LEFT DOOR GROUP	1
37	1T06170	左侧门组件	LEFT SIDE DOOR GROUP	1
38	1T06175	右侧门组件	RIGHT SIDE DOOR GROUP	1
39	1T06019	左上把手	HANDLE, LEFT	1
40	1T06020	右上把手	HANDLE, RIGHT	1
41	1T06176	前挡板组件	RETAINER PLATE GROUP, FRONT	1
42	1T06021	左板	PLATE, LEFT	1
43	1T06022	右板	PLATE, RIGHT	1
44	1T06023	孔板	PLATE	2
45	1B38416	销	PIN	2
46	1T06024	弹簧	SPRING	2
47	1T06025	左把手	HANDLE, LEFT	1
48	1T06026	右把手	HANDIE, RIGHT	1
49	1T06027	套	SLEEVE	2
50	1T06028	压板	PRESS PLATE	4
51	1T06029	衬套	BUSH	2
52	1T06191	盖板	PLATE	2
1	GB5783-86	螺栓 M16×40—10.9	BOLT M16×40—10.9	16
2	GB97.1-85	垫圈 16	WASHER 16	24
3	GB5782-86	螺栓 M12×40—10.9	BOLT M12×40—10.9	10
4	GB97.1-85	垫圈 12	WASHER 12	43
5	GB5782-86	螺栓 M16×50	BOLT M16×50	10
6	GB5783-86	螺栓 M12×30	BOLT M12×30	17
7	GB5783-86	螺栓 M10×25	BOLT M10×25	6
8	GB97.1-85	垫圈 10	WASHER 10	16
9	GB6170-86	螺母 M20—8	NUT M20—8	10
10	GB5783-86	螺栓 M10×20	BOLT M10×20	16
11	GB93-87	垫圈 10	WASHER 10	6

1T06000 顶罩前保护板
TOP COVER—FRONT GUARD

序号 NO.	代 号 PART NO.	名 称 NAME	数量 Q' TY	备注 REMARK
12	GB1152-89	油杯 M10×1 OIL CUP M10×1	6	
13	GB5783-86	螺栓 M20×45 BOLT M20×45	4	
14	GB97.1-85	垫圈 20 WASHER 20	4	
15	GB5783-86	螺栓 M12×25 BOLT M12×25	10	
16	GB5782-86	螺栓 M20×200—10.9 BOLT M20×200—10.9	4	
17	HG4-338-66	油封 140×170×16 OIL SEAL 140×170×16	2	
18	GB5783-86	螺栓 M20×55—10.9 BOLT M20×55—10.9	4	
19	GB5783—86	螺栓 M8×20 BOLT M8×20	8	
20	GB93—87	垫圈 8 WASHER 8	8	
21	GB97.1—85	垫圈 8 WASHER 8	8	

1T07000 机架—后桥箱
FRAME—BEVEL GEAR CASE

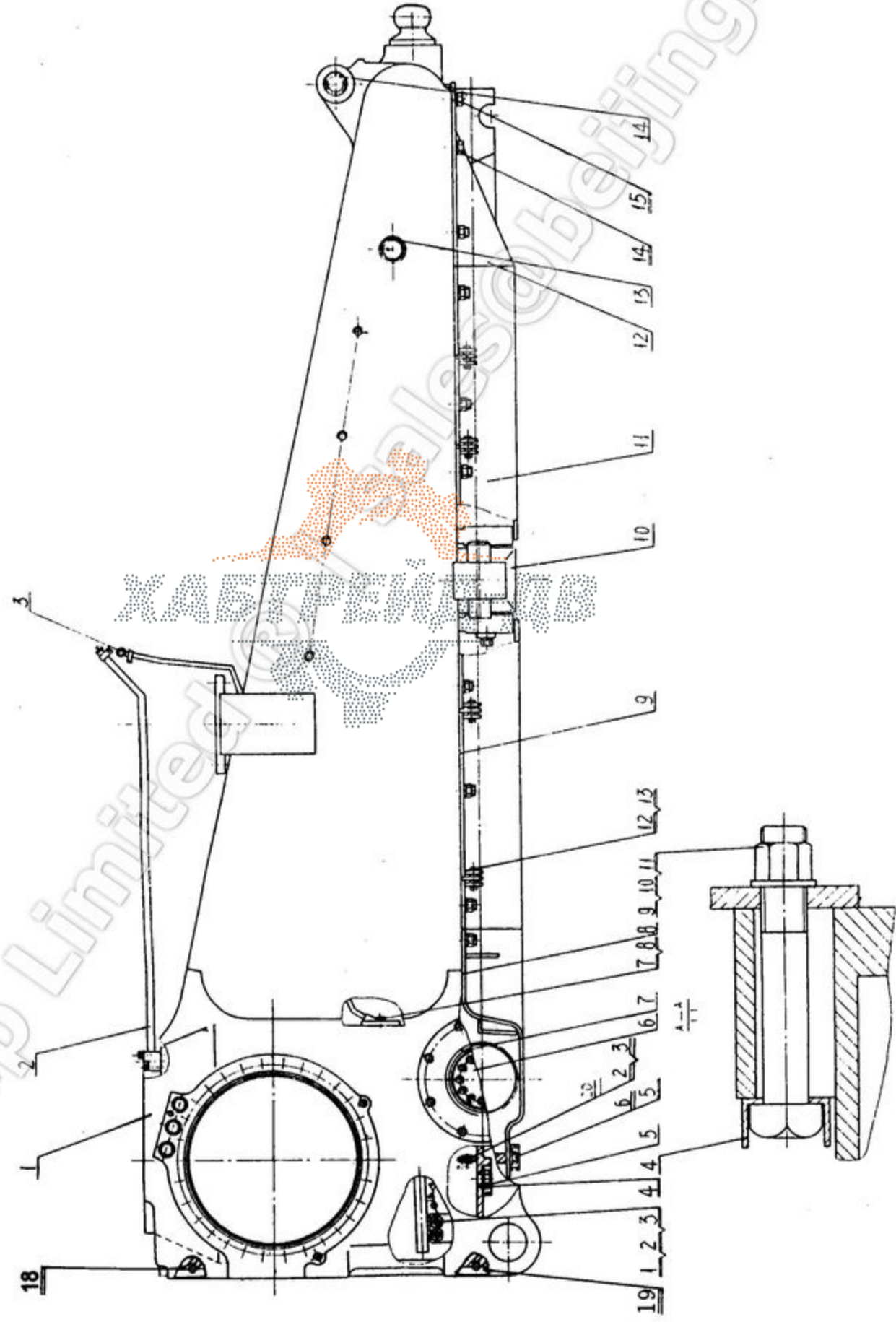

7-1

1T07000 机架—后桥箱
FRAME—BEVEL GEAR CASE

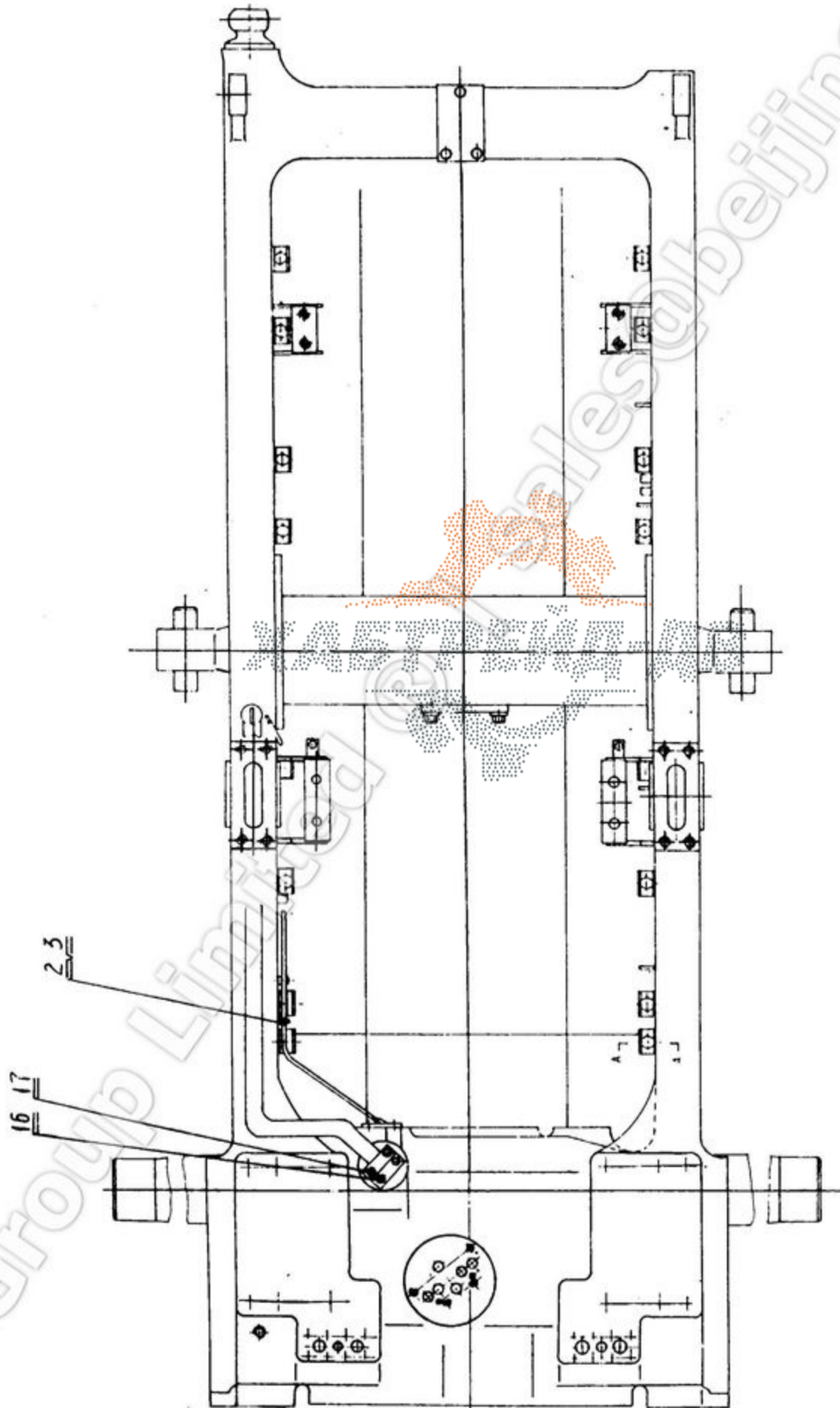

1T07000 机架—后桥箱
FRAME—BEVEL GEAR CASE

序号 NO.	代 号 PART NO.	名 称 NAME	数量 Q' TY	备注 REMARK
1	1T07001	机架—后桥箱焊接	1	
2	1T07049	加油管总成	1	
3	1T07057	油尺总成	1	
4	1T07068	限位块	16	
5	0A10112	磁油塞	1	
6	1T07069	枢轴	1	
7	1T07070	轴套	2	
8	1T07071	后底板	1	
9	1T07080	中后底板	1	
10	1T07092	平衡梁总成	1	
11	1T07110	中前底板	1	
12	1T07120	前底板	1	
13	1T07043	长套	2	
14	1T07044	短套	2	
1	GB5783-86	螺栓 M10×35	4	
2	GB6171-86	螺母 M10	11	
3	GB93-87	弹簧垫圈 10	11	
4	GB1235-76	O形密封圈 42×3.5	1	
5	GB1230-84	垫圈 20	4	
6	GB5783-86	螺栓 M20×40	4	
7	GB5783-86	螺栓 M12×35	2	
8	GB93-87	弹簧垫圈 12	6	
9	GB5782-86	螺栓 M24×150	16	
10	GB6170-86	螺母 M24	16	
11	GB1230-84	垫圈 24	24	
12	GB91-86	开口销 6.3×40	4	
13	GB882-86	销轴 32×70	4	
14	GB5782-86	螺栓 M24×90	6	
15	GB5783-86	螺栓 M24×50	2	
16	GB5782-86	螺栓 M12×65	2	
17	GB5782-86	螺栓 M12×85	2	
18	GB3452.1-82	O型密封圈 40×3.55	3	
19	GB3452.1-82	O型密封圈 54.5×3.55	1	
20	GB97—85	垫圈 10	1	

1T07049 加油管总成 FILLER LINE

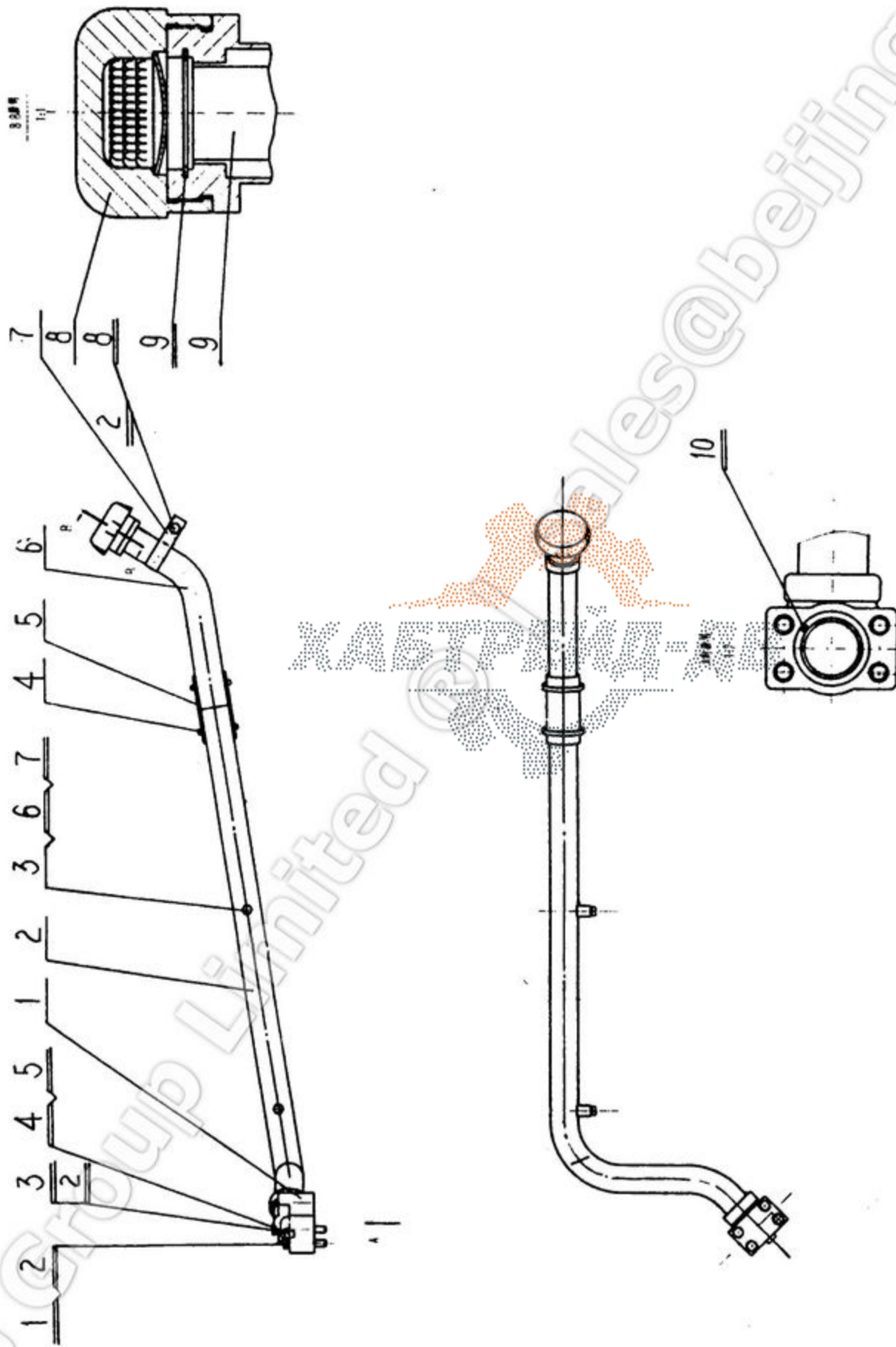

1T07049 加油管总成 FILLER LINE

序号 NO.	代 号 PART NO.	名 称 NAME	数量 Q' TY	备注 REMARK
1	1T07050	管座	1	
2	1T07052	管(一)	1	
3	1T07051	螺纹座	2	
4	1T07137	不锈钢喉箍 3(51-70)	2	
5	1T07053	软管	1	
6	1T07054	加油管焊接	1	
7	1T07055	管夹子	1	
8	0A20089	加油口盖	1	
9	0A20093	滤网	1	
1	GB5783—86	螺栓 M12×60	2	
2	GB93—87	垫圈 12	5	
3	GB5783—86	螺栓 M12×80	2	
4	JB/ZQ444—86	螺塞 M16×1.5	1	
5	JB/ZQ4454-86	密封垫 16×20	1	
6	GB5783-86	螺栓 M10×20	2	
7	GB93—87	垫圈 10	2	
8	GB5783-86	螺栓 M12×30	1	
9	GB893-76	挡圈 42	1	
10	GB3452.1-82	O形圈 45×3.55	1	

1T07057 油尺总成 OIL DIPSTICK ASSEM

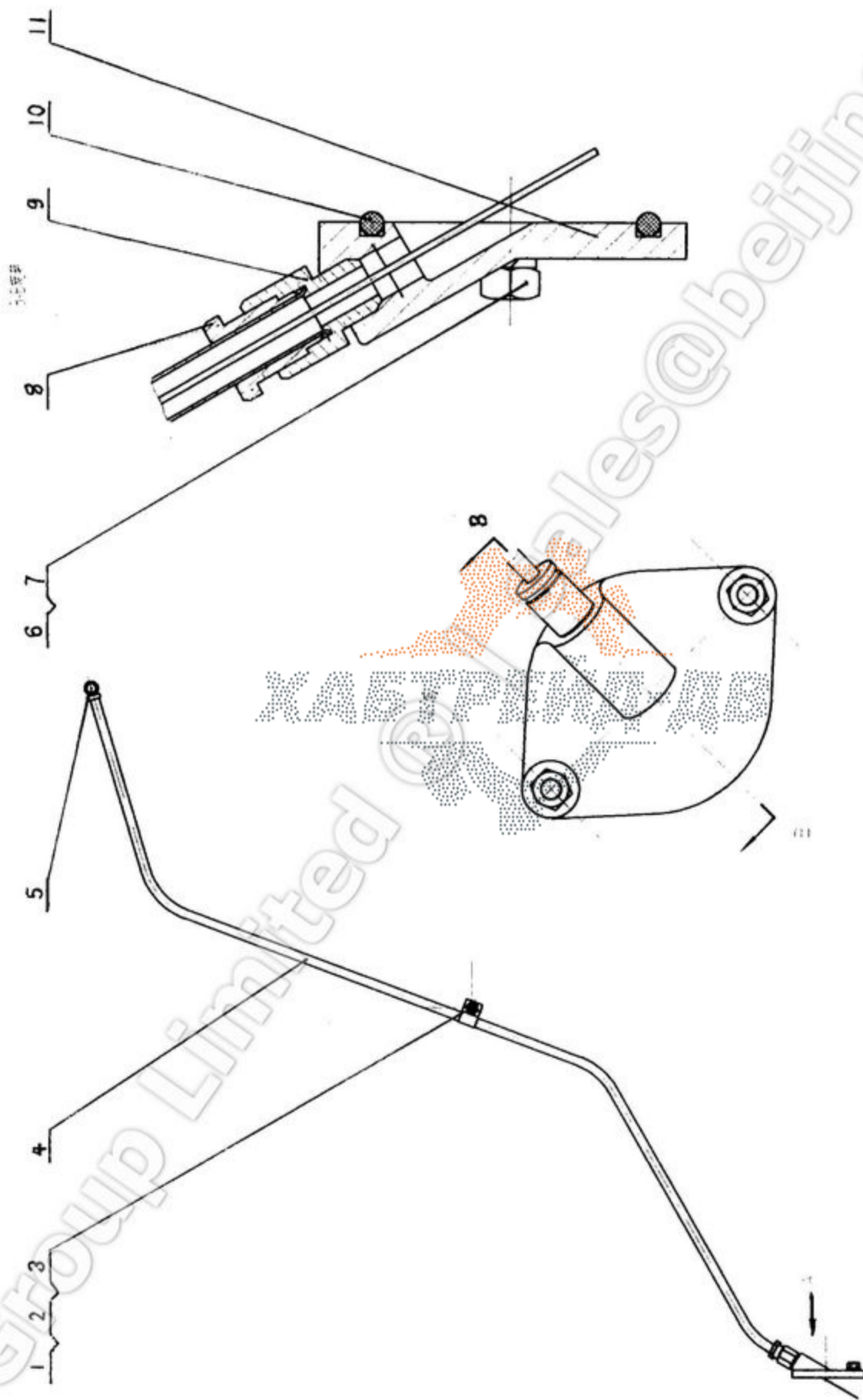

1T07057 油尺总成 OIL DIPSTICK ASSEM

序号 NO.	代 号 PART NO.	名 称 NAME	数量 Q' TY	备注 REMARK
1	1T07067	线夹子 CLIP	1	
2	GB93-87	垫圈 10 WASHER 10	1	
3	GB5783-86	螺栓 M10×20 BOLT M10×20	1	
4	1T07062	油尺外管 EXTERNAL LINE	1	
5	1T07058	油尺组件 OIL DIPSTICK	1	
6	GB93-87	垫圈 12 WASHER 12	2	
7	GB5783-86	螺栓 M12×40 BOLT M12×40	2	
8	1T07063	小螺纹套 SLEEVE	1	
9	1T07064	大螺纹套 SLEEVE	1	
10	GB3452.1-92	O 形圈 80×5.3 O-RING	1	
11	1T07065	油尺座 SEAT, DIPSTICK	1	

1T07092 平衡梁总成 EQUALIZER BAR ASSEM

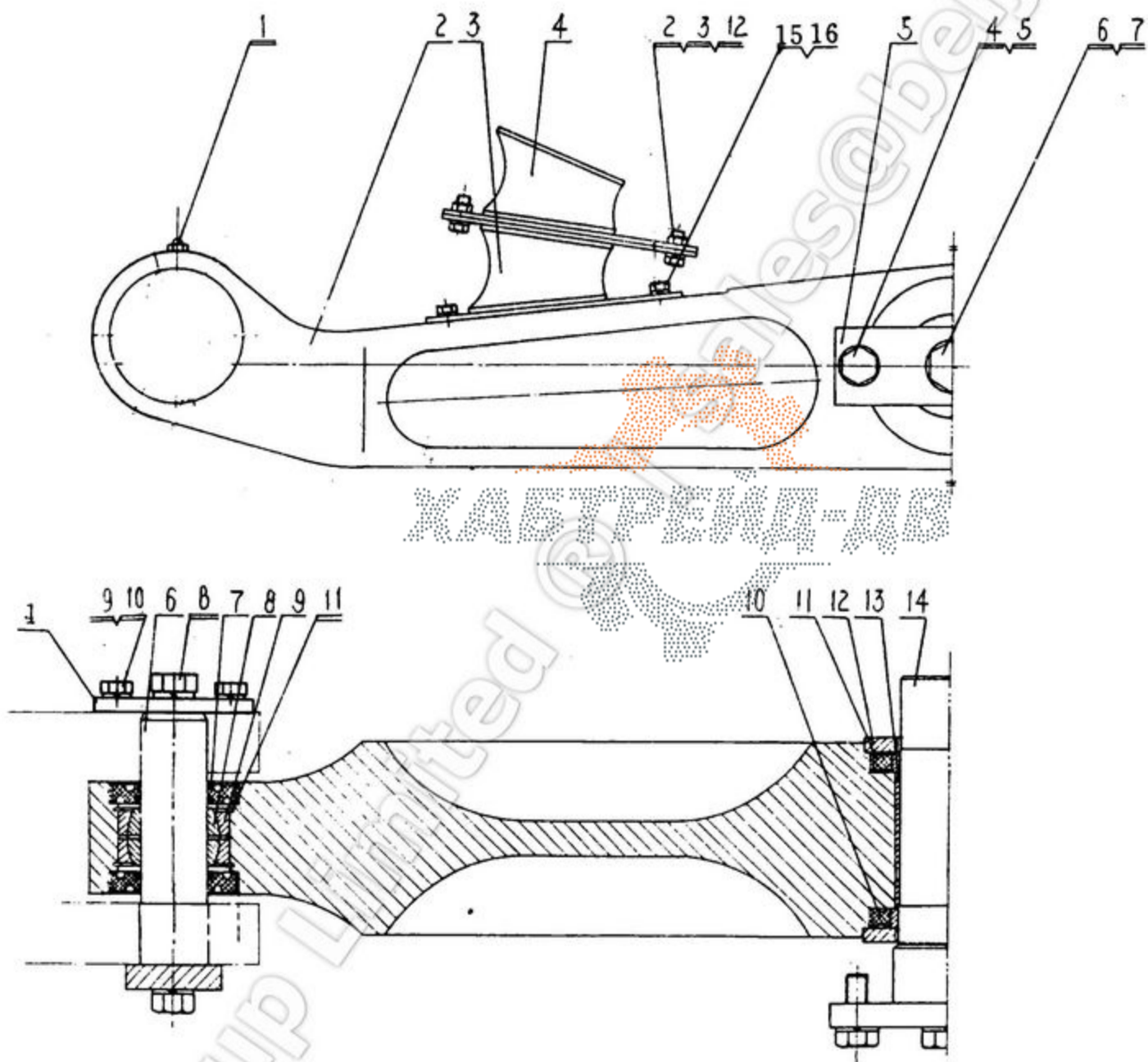

1T07092 平衡梁总成 EQUALIZER BAR ASSEM

序号 NO.	代 号 PART NO.	名 称 NAME	数量 Q'TY	备注 REMARK
1	1T07093	法兰板	2	
2	1T07094	平衡梁体	1	
3	1T07095	下橡胶块	2	
4	1T07099	上橡胶块	2	
5	0T07142	挡板	1	
6	1T07101	销轴	2	
7	0T07112	密封垫	4	
8	0T07092	球铰	2	
9	0T07091	铰套	4	
10	1T07106	防尘圈(二)	1	
11	1T07102	防尘圈(一)	1	
12	1T07135	挡环	2	
13	1T07108	衬套	1	
14	1T07109	大销轴	1	
15	1T07140	垫	4	
16	1T07141	垫	4	
1	GB1172—79	油杯 M10×1	2	
2	GB5783—86	螺栓 M12×25	16	
3	GB93—87	垫圈 12	16	
4	GB5782—86	螺栓 M24×60	2	
5	GB93—87	垫圈 24	4	
6	GB5782—86	螺栓 M30×70	1	
7	GB93—87	垫圈 30	1	
8	GB5782—86	螺栓 M24×50	2	
9	GB93—87	垫圈 M16	4	
10	GB5782—86	螺栓 M16×35	4	
11	GB893.1—86	挡圈 115	4	
12	GB6170—86	螺母 M12—8	8	

1T08000 左右弯板组件
LEFT & RIGHT ELBOW PLATE GROUP

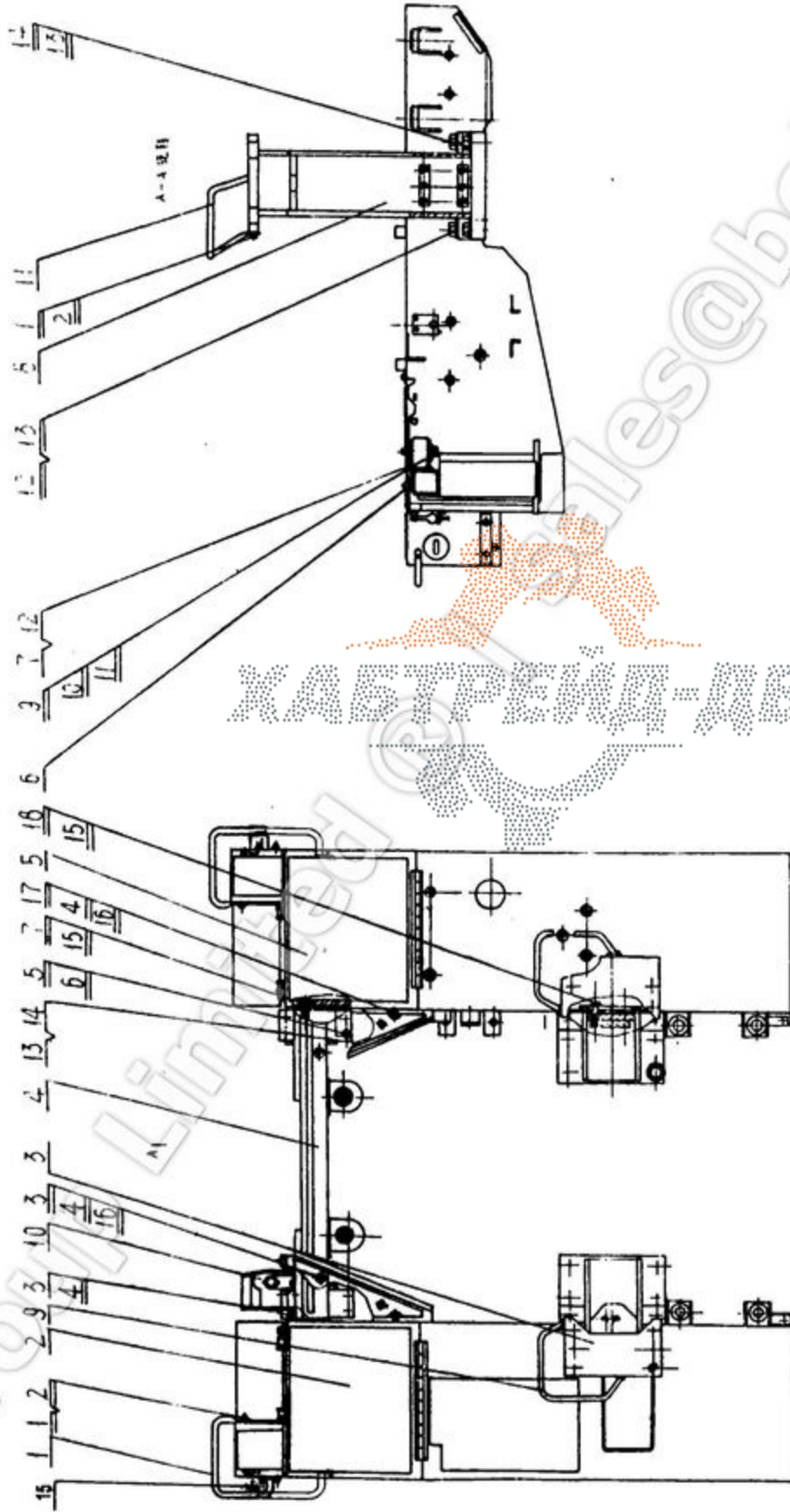

1T08000 左右弯板组件
LEFT & RIGHT ELBOW PIATE GROUP

序号 NO.	代 号 PART NO.	名 称 NAME	数量 Q' TY	备注 REMARK
1	1T08001	扶手组件	2	
2	1T08004	左弯座	1	
3	1T08057	左支腿	1	
4	1T08067	横梁	1	
5	1T08086	右弯座	1	
6	1T08097	密封条	1	
7	1T15022	缓冲垫	4	
8	1T08098	右支腿	1	
9	1T08099	左扶手	1	
10	1T08100	枢轴润滑系	1	
11	1T08122	右扶手	1	
12	1T15011	盖	2	
13	1T08123	右角板组件	1	
14	1T08127	左角板组件	1	
15	1T08130	扶手组件	2	
1	GB5783-86	螺栓 M12×25	14	
2	GB97.1-85	垫圈 12	14	
3	GB5783-86	螺栓 M10×25	6	
4	GB97.1-85	垫圈 10	8	
5	GB5782-86	螺栓 M24×50-10.9	8	
6	GB97.1-85	垫圈 24	8	
7	GB5783-86	螺栓 M16×35-10.9	12	
8	GB5782-86	螺栓 M16×70	12	
9	GB5782-86	螺栓 M20×130	2	
10	GB93-87	垫圈 20	2	
11	GB5287-85	垫圈 20	2	
12	GB5782-86	螺栓 M36×160-10.9	4	
13	GB97.2-85	垫圈 36	12	
14	GB5782-86	螺栓 M36×110-10.9	8	
15	GB97.1-85	垫圈 16	24	
16	GB93-87	垫圈 10	4	
17	GB5782-86	螺栓 M10×50	2	

1T09000 变速阀操纵
TRANSMISSION VALVE CONTROL

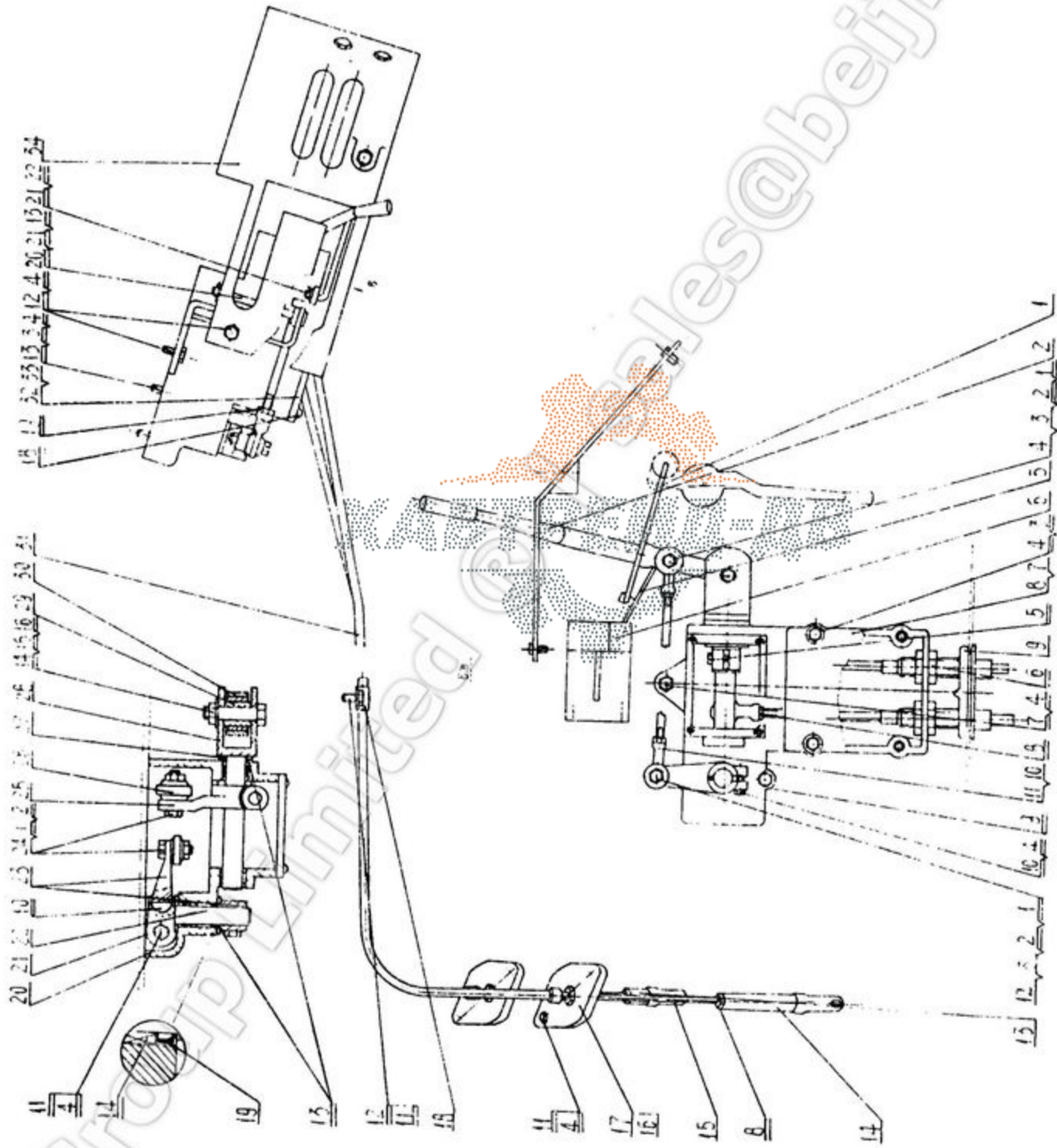

1T09000 变速阀操纵
TRANSMISSION VALVE CONTROL

序号 NO.	代 号 PART NO.	名 称 NAME	数量 Q'TY	备注 REMARK
1	1T09001	拉杆	ROD	1
2	0T09025	变速杆	SPEED CONTROL LEVER	1
3	0T09053	挡圈	SPACER RING	4
4	0T09054	螺栓轴	SHAFT BOLT	1
5	0T09003	限位板	DETENT PLATE	1
6	0T09031	支座	SUPPORT	1
7	0T09004	盖板	COVER PLATE	1
8	0T09005	垫	GASKET	1
9	0T09006	防尘皮碗	DUST PROOF BOWL	1
10	0T09007	拉杆	ROD	1
11	0T09035	关节轴承组件	BEARING GROUP	2
12	0T09002	螺栓轴	BOLT SHAFT	1
13	0T09009	叉头	YOKE	1
14	0T09040	叉头焊接体	WELD	1
15	0T09037	销轴组件	PIN SHAFT GROUP	2
16	0T09010	压板	PERSS PLATE	2
17	0T09011	垫	GASKET	2
18	0T09012	卡子	CLIP	1
19	0T09043	防尘环	DUST PROOF RING	3
20	0T09013	操纵盒	CONTROL BOX	1
21	0T09014	垫	GASKET	1
22	0T09015	短轴	SHAFT	1
23	0T09016	摇臂	ROCKER	2
24	0T09008	螺栓轴	SHAFT,BOLT	2
25	0T09017	摇臂	ROCKER	1
26	0T09046	关节轴承组件	BEARING SET	2
27	0T09018	隔垫	SPACER	1
28	0T09048	叉轴	SHAFT	1
29	0T09019	隔套	BAFFLE	1
30	0T09020	铜套	COPPER SLEEVE	1
31	1T09002	软轴	CABLE SHAFT	2
32	0T09022	盖	COVER	1

1T09000 变速阀操纵
TRANSMISSION VALVE CONTROL

序号 NO.	代 号 PART NO.	名 称 NAME	数量 Q'TY	备注 REMARK
33	0T09023	垫	1	
34	1T09003	标志面板	1	
1	GB6178-86	螺母 M10	4	
2	GB91-86	销 2×20	4	
3	GB5782-86	螺栓 M10×90	6	
4	GB93-76	垫圈 10	21	
5	GB5783-86	螺栓 M10×25	1	
6	GB6176-86	螺母 M12×1.25	6	
7	GB5782-86	螺栓 M10×45	1	
8	GB6174-86	螺母 M16	4	
9	GB1099-79	键 3×16	3	
10	GB5783-86	螺栓 M10×30	3	
11	GB5783-86	螺栓 M10×20	12	
12	GB95-85	垫 10	9	
13	GB95-85	垫 20	4	
14	GB290-89	滚针轴承 HK202612	4	
15	GB5782-86	螺栓 M12×50	1	
16	GB6170-86	螺母 M12	1	
17	GB93-76	垫 12	1	
18	GB5783-86	螺栓 M6×12	4	
19	GB6170-86	螺母 M10-8	2	
20	GB882-86	销 B10×95	1	
21	GB91-86	销 3.2×16	3	
22	GB95-85	垫 8	2	

1T10000 转向制动操纵
STEERING BRAKE CONTROL

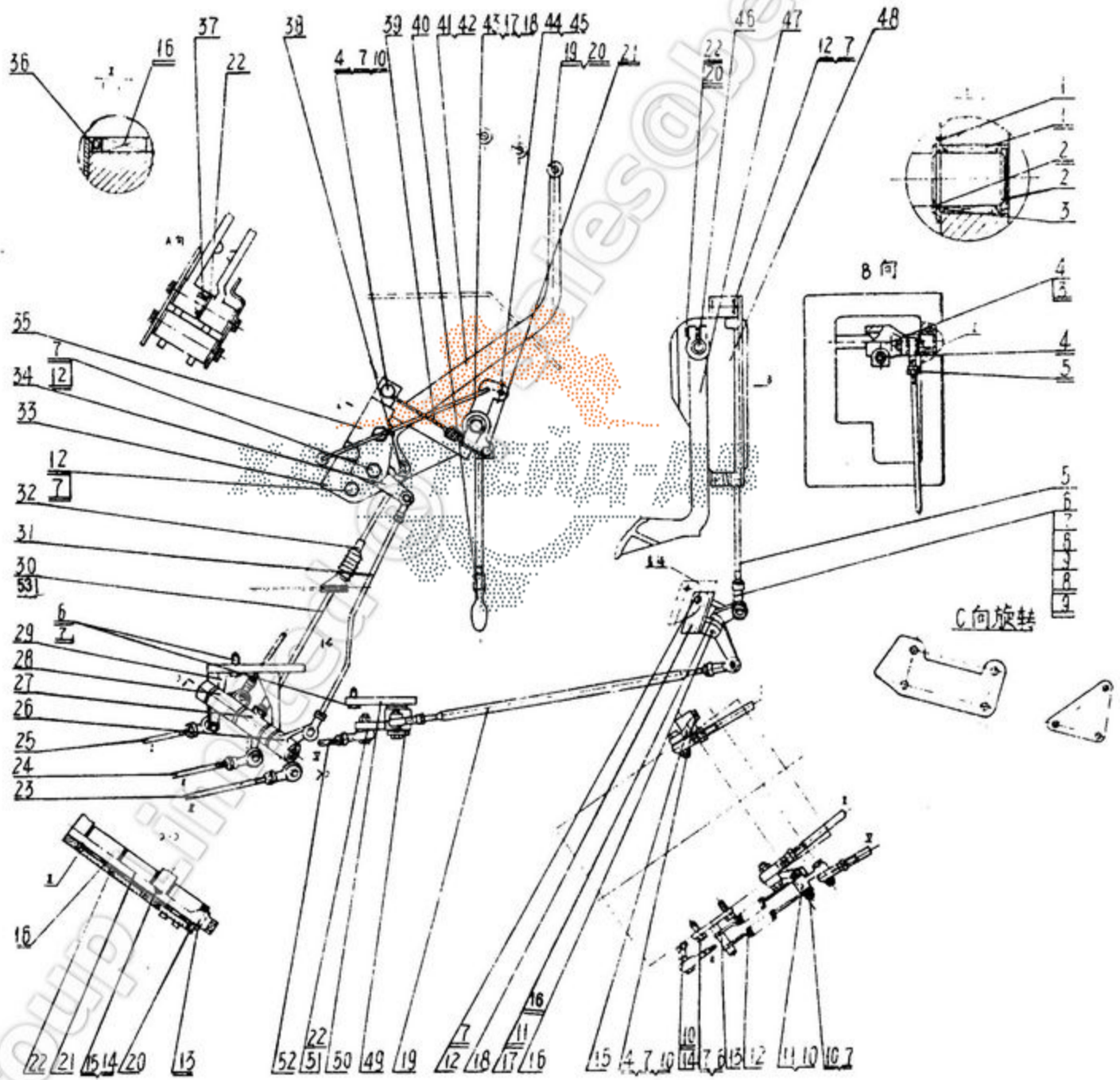

1T10000 转向制动操纵
STEERING BRAKE CONTROL

序号 NO.	代 号 PART NO.	名 称 NAME	数量 Q' TY	备注 REMARK
1	0T10006	隔圈	1	
2	0T10092	轴承座	1	
3	0A03050	密封件	3	
4	1T10002	摆动体	1	
5	1T10007	脚别动拉杆	1	
6	1T10008	拉杆头	18	
7	0T10017	护套	18	
8	0T10063	轴套	36	
9	0T10009	转轴	16	
10	0T10028	拉簧套	2	
11	0T10027	摇臂	1	
12	0T10032	拉簧	2	
13	0T10029	拉簧座	1	
14	0T10033	摇臂	1	
15	0T10026	摇臂	2	
16	1T10009	轴	1	
17	1T10010	曲拐	1	
18	1T10011	脚别动座	1	
19	1T10012	大拉杆	1	
20	1T10023	隔套	1	
21	1T10024	斜轴	1	
22	0T10035	隔片	16	
23	1T10025	制动杆	1	
24	1T10026	右拉杆	1	
25	1T10027	左拉杆	1	
26	1T10028	曲拐 1	1	
27	1T10029	曲拐 2	1	
28	1T10030	曲拐 3	1	
29	1T10031	斜轴座	1	
30	1T10032	拉杆	1	
31	1T10033	拉杆	1	
32	1T10034	防尘套	3	

1T10000 转向制动操纵
STEERING BRAKE CONTROL

序号 NO.	代 号 PART NO.	名 称 NAME	数量 Q'TY	备注 REMARK
33	0T10046	侧连板	CONNECTING PLATE	1
34	0T10045	摇臂	ROCKER	1
35	0T10072	轴支架	SUPPORT, SHAFT	1
36	0T09043	防尘环	DUST PROOF RING	20
37	0T10047	轴	SHAFT	2
38	0T10016	螺栓轴	SHAFT BOLT	2
39	0T10071	簧	SPRING	1
40	0A11030	手柄	HANDLE	3
41	1T10036	左操纵杆	CONTROL LEVER, LEFT	1
42	1T10038	右操纵杆	CONTROL LEVER, RIGHT	1
43	1T10039	连杆	ROD	1
44	0T10085	锁车制动手柄	HANDLE BRAKE	1
45	0T10060	轴	SHAFT	1
46	1T10040	花键轴	SHAFT, SPLINE	1
47	1T10041	脚踏板	PEDAL	1
48	1T10042	壳体	HOUSING	1
49	0T10080	压板	PRESS PLATE	1
50	0T10081	制动后支座	SUPPORT	1
51	1T10043	摇臂	ROCKER	1
52	1T10044	拉杆	ROD	1
53	1T10051	拉杆	ROD	1
1	GB290-89	滚针轴承 HK253220	NEEDLE BEARRNG HK253220	2
2	GB894.1-86	挡圈 25	BAFFLE 25	1
3	GB1089-79	半元键 6×10×25	KEY 6.0×10×25	1
4	GB5782-86	螺栓 M10×40	BOLT M10×40	6
5	GB6170-86	螺母 M12-8	NUT M12-8	18
6	GB5782-86	螺栓 M10×25	BOLT M10×25	11
7	GB93-87	垫 10	WASHER 10	35
8	GB6178-86	螺母 M12	NUT M12	16
9	GB91-86	销 2.5×25	PIN 2.5×25	18
10	GB6170-86	螺母 M10-8	NUT M10-8	6

1T10000 转向制动操纵
STEERING BRAKE CONTROL

序号 NO.	代 号 PART NO.	名 称 NAME	数量 Q' TY	备注 REMARK
11	GB879-86	弹簧销 5×35	1	
12	GB5782—86	螺栓 M10×30	18	
13	GB894.1-86	挡圈 20	1	
14	GB5782-86	螺栓 M8×45	1	
15	GB93-87	垫圈 8	1	
16	GB290-89	滚针轴承 HK201616	18	
17	GB95-86	垫圈 10	2	
18	GB91-86	销 3×20	2	
19	GB5782-86	螺栓 M12×35	2	
20	GB93-86	垫圈 10	2	
21	GB5782-86	螺栓 M8×20	1	
22	GB5782-86	螺栓 M10×50	1	

1T11000 油门操纵 GOVERNOR CONTROL

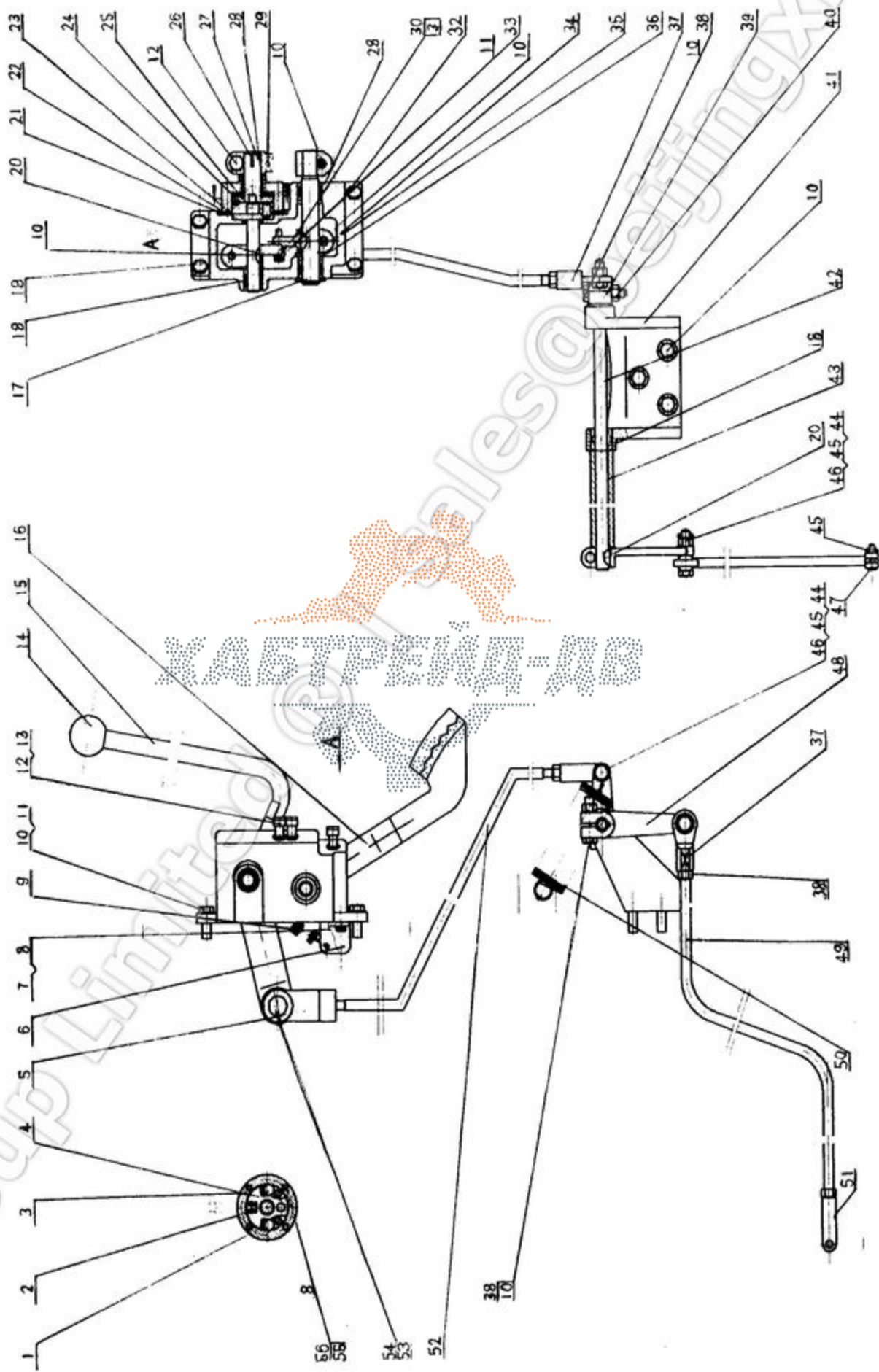

1T11000 油门操纵 GOVER NOR GONTROL

序号 NO.	代 号 PART NO.	名 称 NAME	数量 Q' TY	备注 REMARK
1	1B03021	弹簧	2	
2	1B03019	弹簧	1	
3	1B03025	滚柱	2	
4	0T11026	锁定板组件	1	
5	1T11004	叉头	1	
6	1T11003	小弯座	1	
7	GB5781-85	螺栓 M6×15	2	
8	GB93-87	垫圈 6	6	
9	1T11005	弹簧	1	
10	GB5783-86	螺栓 M10×30	9	
11	GB93-87	垫圈 10	12	
12	GB5783-86	螺栓 M10×40	4	
13	GB6172-82	螺母 10	3	
14	0A03042	操纵手柄	1	
15	1T11006	手拉杆	1	
16	1T11010	脚踏板	1	
17	GB894.1-86	挡圈 20	1	
18	GB290-82	轴承 943/15	3	
19	1T11013	小摇臂	1	
20	GB1099-79	键 4×19	3	
21	1B03023	唇式密封圈	1	
22	0T11012	隔环	1	
23	1T11014	垫片	2	
24	1T11016	自锁壳体	1	
25	1T11017	驱动轴	1	
26	GB1099-79	键 5×19	2	
27	1T11020	主动轴组件	1	
28	GB290-82	轴承 70941/20	3	
29	0T11013	碟簧	1	
30	1T11036	套	1	

1T11000 油门操纵 GOVER NOR GONTROL

序号 NO.	代 号 PART NO.	名 称 NAME	数量 Q' TY	备注 REMARK
31	1T11037	套	1	
32	1T11023	操纵盒	1	
33	GB27-88	螺栓 M10×25	1	
34	1T11024	摇臂块	1	
35	1T11025	轴	1	
36	GB97.1-85	垫圈 20	2	
37	0T09035	关节轴承组件	2	
38	GB6170-87	螺母 M10	7	
39	1T11026	右摇臂	1	
40	GB93-87	垫圈 16	1	
41	1T11027	支座	1	
42	1T11028	摇臂轴	1	
43	1T11029	隔套	1	
44	GB6178-86	螺母 M10-8	2	
45	GB91-86	销 2×20	3	
46	0T09008	螺栓轴	2	
47	GB882-86	销 6×25	1	
48	1T11034	左摇臂	1	
49	1T11030	拉杆	1	
50	1B03027	拉簧	1	
51	1T11033	叉头	1	
52	1T11035	竖拉杆	1	
53	GB882-86	销 8×40	1	
54	GB91-86	销 3.2×50	1	
55	GB5783-86	螺栓 M6×50	4	
56	GB95-85	垫圈 6	4	

1T12000 底盘液压系统
HYDRAULIC SYSTEM

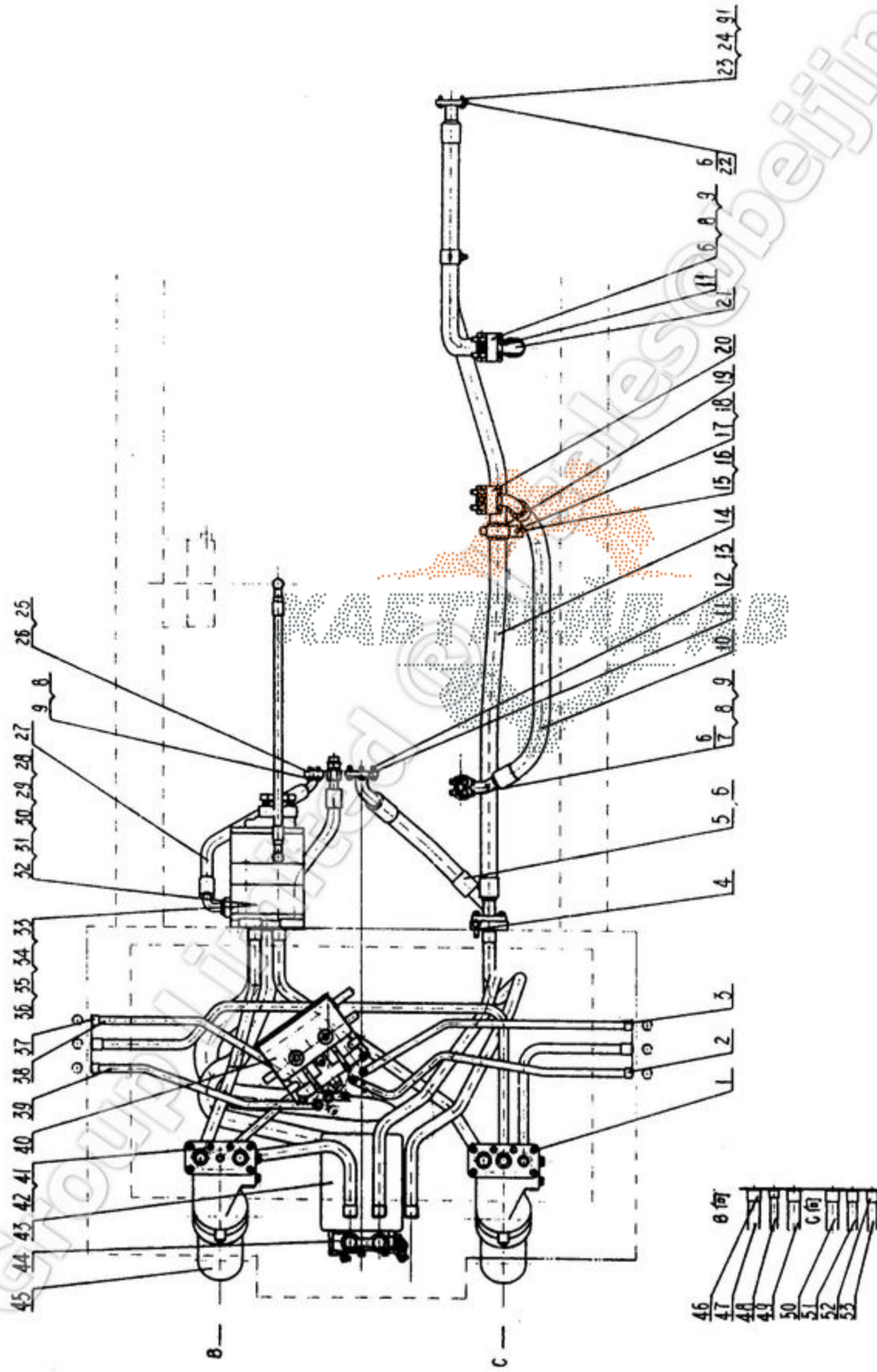

1T12000 底盘液压系统
HYDRAULIC SYSTEM

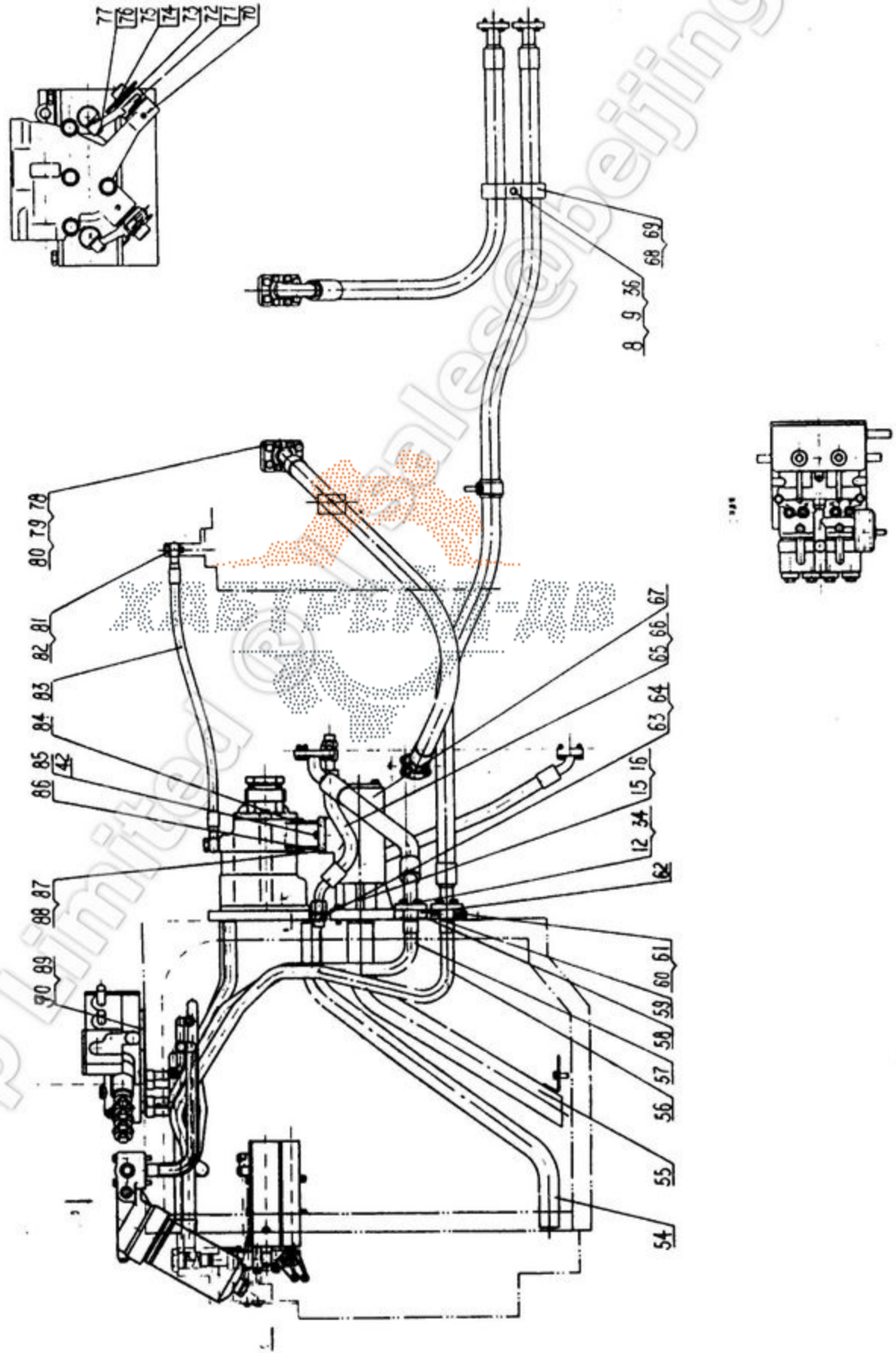

1T12000 底盘液压系统
HYDRAULIC SYSTEM

序号 NO.	代 号 PART NO.	名 称 NAME	数量 Q' TY	备注 REMARK	
1	GB5782-86	螺栓 M10×95	BOLT M10×95	2	
2	1T12073	右制动硬管	BRAKE PIPE,RIGHT	1	
3	1T12072	右转向硬管	STEERING PIPE,RIGHT	1	
4	GB70-85	螺钉 M12×30	SCREW M12×30	1	
5	1T12074	变矩器进油管	INLET OIL PIPE,CONVERTER	1	
6	GB3452.1-92	O形圈 37.5×3.55	O-SEAL RING 37.5×3.55	8	
7	0K28004	压盖	PRESS COVER	6	
8	GB93-87	垫圈 10	WASHER 10	42	
9	GB5783-86	螺栓 M10×30	BOLT M10×30	25	
10	1T12111	变矩器出油管	OUTLET OIL PIPE,CONVERTER	1	
11	1T12012	压盖(半)	PRESS COVER(HALF)	6	
12	GB93-87	垫圈 12	WASHER 12	20	
13	GB5783-86	螺栓 M12×30	BOLT M12×30	4	
14	1T12112	冷却回油软管	HOSE,COOLING RETURN OIL	1	
15	GB5782-86	螺栓 M12×40	BOLT M12×40	8	
16	GB97.1-85	垫圈 12	WASHER 12	12	
17	1T12078	管夹(半)	CLAMP(HALF)	1	
18	1T12079	管夹(半)	CLAMP(HALF)	1	
19	1T12011	护套	GUARD SLEEVE	1	
20	1T12109	连接板	PLATE	2	
21	1T12113	冷却中油管	OIL PIPE,COOLER	1	
22	1T12001	压盖(半)	PRESS COVER(HALF)	4	
23	GB5783-86	螺栓 M8×30	BOLT M8×30	8	
24	GB93-87	垫圈 8	WASHER 8	8	
25	1B06072	法兰	FLANGE	4	
26	GB3452.1-92	O形圈 25×3.55	O-SEAL RING 25×3.55	2	
27	1T12013	变矩器吸油管	SUCTION PIPE,CONVERTER	1	
28	1T12018	底盘泵总成	PUMP ASSEM.	1	
29	GB3452.1-92	O形圈 40×2.65	O-RING 40×2.65	1	
30	GB3452.1-92	O形圈 54.5×2.65	O-RING 54.5×2.65	1	
31	GB3452.1-92	O形圈 63×2.65	O-RING 63×2.65	1	
32	GB3452.1-92	O形圈 145×2.65	O-RING 145×2.65	1	

1T12000 底盘液压系统
HYDRAULIC SYSTEM

序号 NO.	代 号 PART NO.	名 称 NAME	数量 Q'TY	备注 REMARK	
33	GB5782-86	螺栓 M12×100	BOLT M12×100	2	
34	GB5782-86	螺栓 M12×55	BOLT M12×55	10	
35	GB897-88	螺柱 M10×25	BOLT M10×25	3	
36	GB6170-86	螺母 M10	NUT M10	4	
37	0T12019	套(1)	SLEEVE(1)	10	
38	1T12054	左制动硬管	BRAKE PIPE,LEFT	1	
39	1T12053	左转向硬管	STEERING PIPE,LEFT	1	
40	0T12200	转向制动阀	STEERING BRAKE VALVE	1	
41	GB5782-86	螺栓 M10×90	BOLT M10×90	10	
42	GB97.1-85	垫圈 10	WASHER 10	14	
43	1T12100	变速箱控制阀总成	CONTROL VALVE ASSEM	1	
44	0T12192	顺序阀	SEQUENCE VALVE	1	
45	1T12055	细滤器总成	SECONDARY FILTER	2	
46	1T12066	套(1)	SLEEVE(1)	10	
47	1T12067	泵油硬管	OIL PIPE	1	
48	1T12068	去转向制动阀硬管	PIPE TO STEERING BRAKE VALVE	1	
49	1T12069	去变速阀组硬管	PIPE TO TRANSMISSION VALVE GROUP	1	
50	1T12070	润滑泵油硬管	PIPE,LUBE	1	
51	1T12052	左润滑硬管	PIPE LUBRICANT,LEFT	1	
52	1T12051	套(—1)	SLEEVE(1)	4	
53	1T12071	右润滑硬管	PIPE LUBRICANT,RIGHT	1	
54	1T12093	变速箱排油硬管	DRAIN PIPE,TRANSMISSION	1	
55	1T12092	泵吸油硬管焊接	OIL PIPE WELD	1	
56	1T12090	变速箱润滑硬管	PIPE LVBRICANT,TRANSMISSZON	1	
57	1T12091	变矩器进油硬管	INLET OIL PIPE,CONVERTER	1	
58	GB3452.1-92	O形圈 21.2×3.55	O-RING 21.2×3.55	1	
59	GB3452.1-92	O形圈 46.2×3.55	O-RING 46.2×3.55	2	
60	JB1000-77	螺塞 M10×1	SCREW PIUG M10×1	1	
61	JB982-77	密封垫 10	SEAL GASKET 10	1	
62	1T12089	分油板	OIL SPLITTING PLATE	1	
63	JB982-77	密封垫 27	GASKET 27	2	
64	1T12088	螺纹接头	THREAD JOINT	2	

1T12000 底盘液压系统
HYDRAULIC SYSTEM

序号 NO.	代 号 PART NO.	名 称 NAME	数量 Q' TY	备注 REMARK
65	1T12082	通气管	1	
66	GB3452.1-92	O形圈 15×2.65	2	
67	1T12080	粗滤器总成	1	
68	0T12010	管夹(半)	2	
69	0T12011	管夹(半)	2	
70	GB879-86	销 6×35	2	
71	0T12032	摇臂	2	
72	GB290—82	轴承 40941/20	2	
73	0T12037	隔环	4	
74	0T12033	枢轴	2	
75	0T12031	弹性挡销	2	
76	0T12034	销	2	
77	GB894.1-86	挡圈 8	4	
78	1B01271	螺栓	8	
79	1B01253	垫圈	8	
80	GB3452.1-92	O形圈 58×3.55	2	
81	0A09020	油塞	2	
82	0A09021	垫	4	
83	1T12096	分动箱润滑管	1	
84	GB3452.1-92	O形圈 65×2.65	2	
85	GB5782-86	螺栓 M10×40	2	
86	1T12095	接管	1	
87	1T12094	法兰	1	
88	GB3452.1-92	O形圈 77.5×3.55	1	
89	GB3452.1-92	O形圈 28×2.65	12	
90	0T12102	垫板	1	
91	GB97.1-85	垫圈 8	4	

0T12200 转向制动阀 STEERING BRAKE VALVE

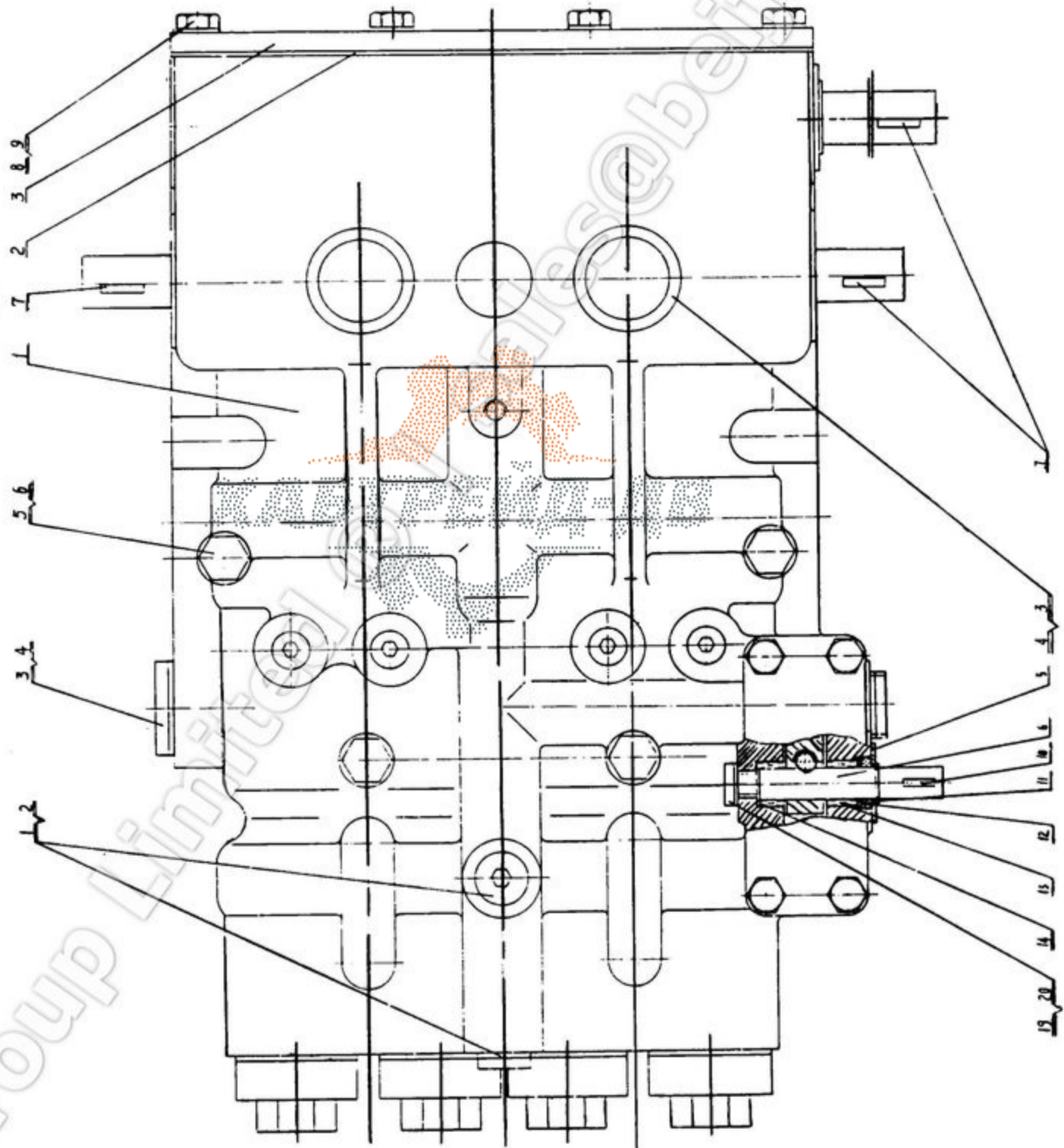

0T12200 转向制动阀 STEERING BRAKE VALVE

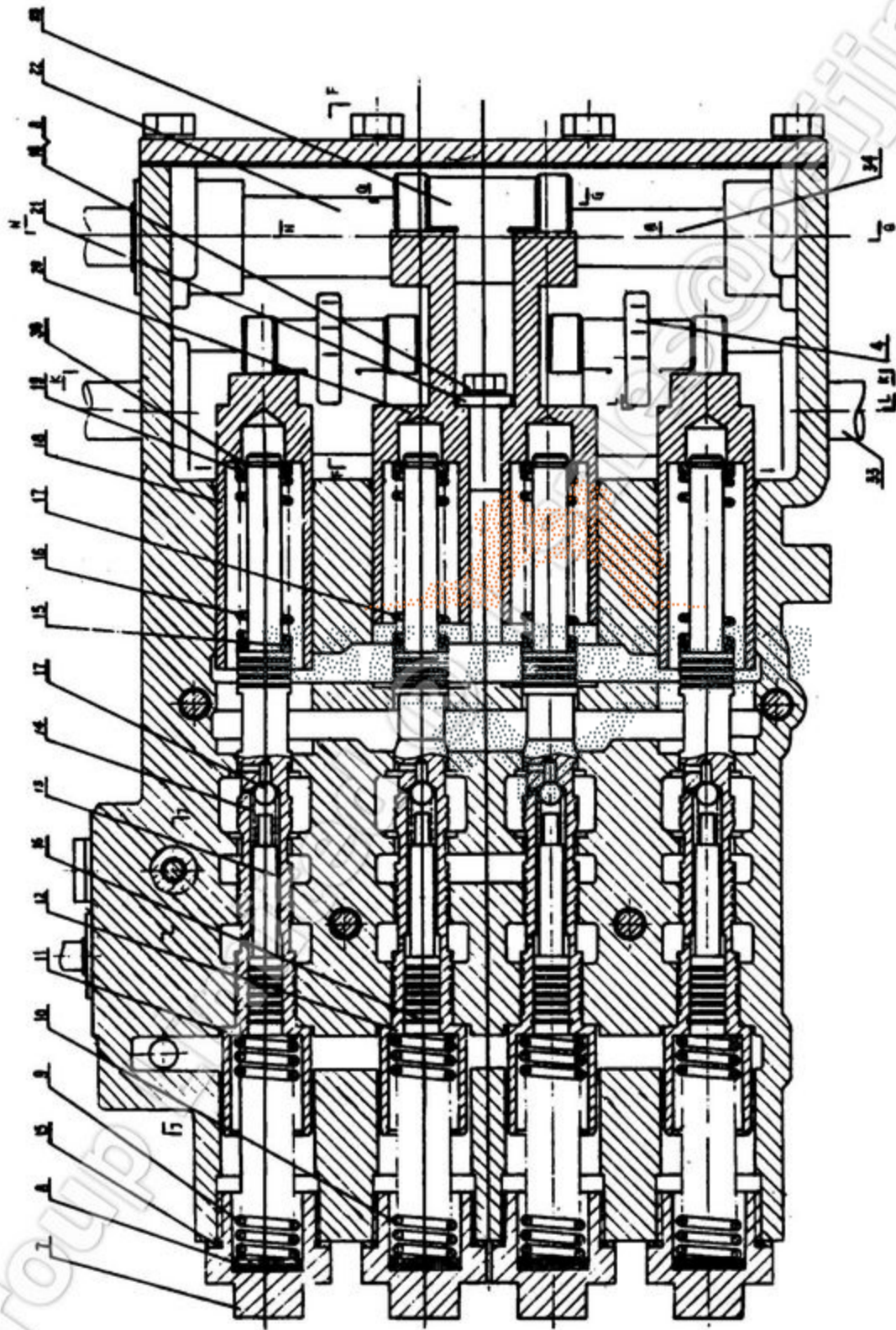

0T12200

转向制动阀

STEERING BRAKE VALVE

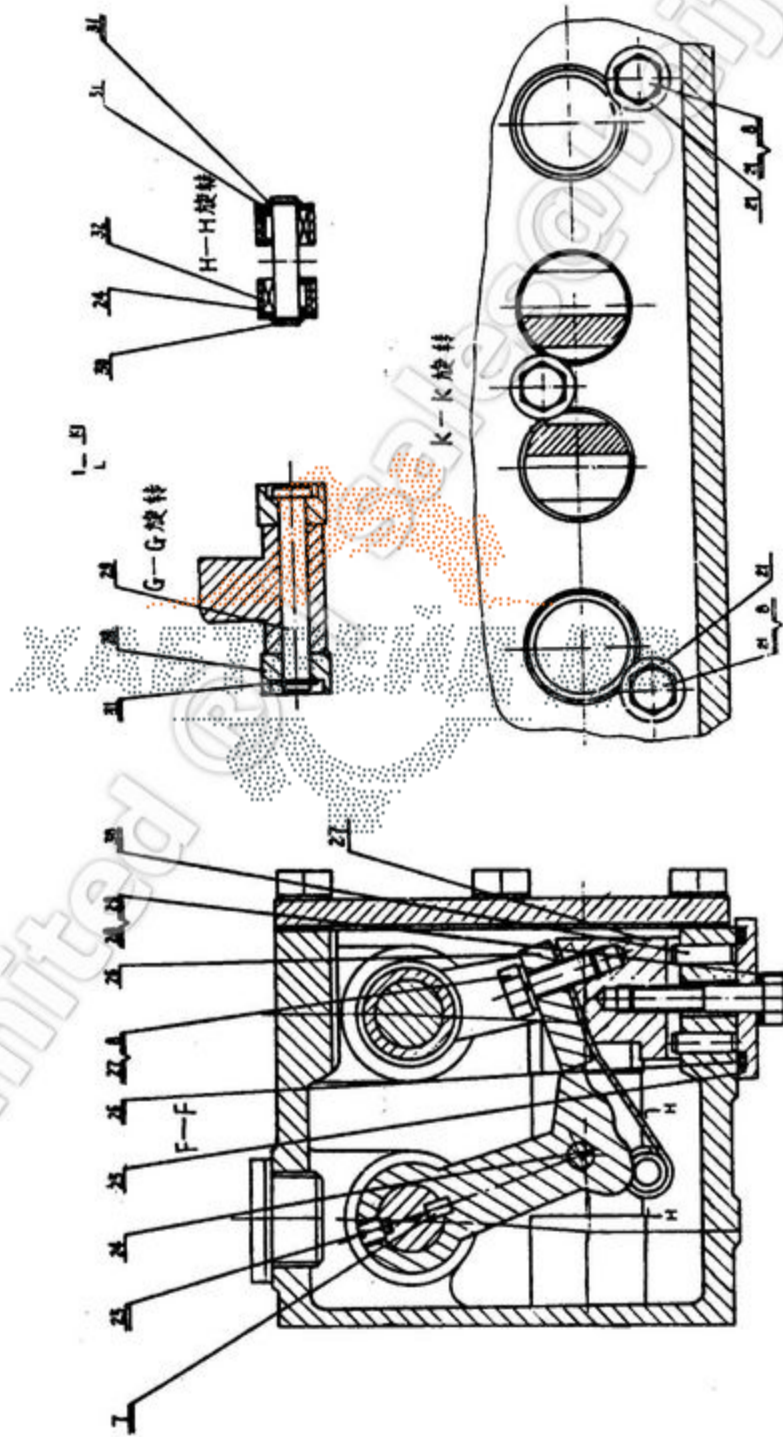

0T12200 转向制动阀 STEERING BRAKE VALVE

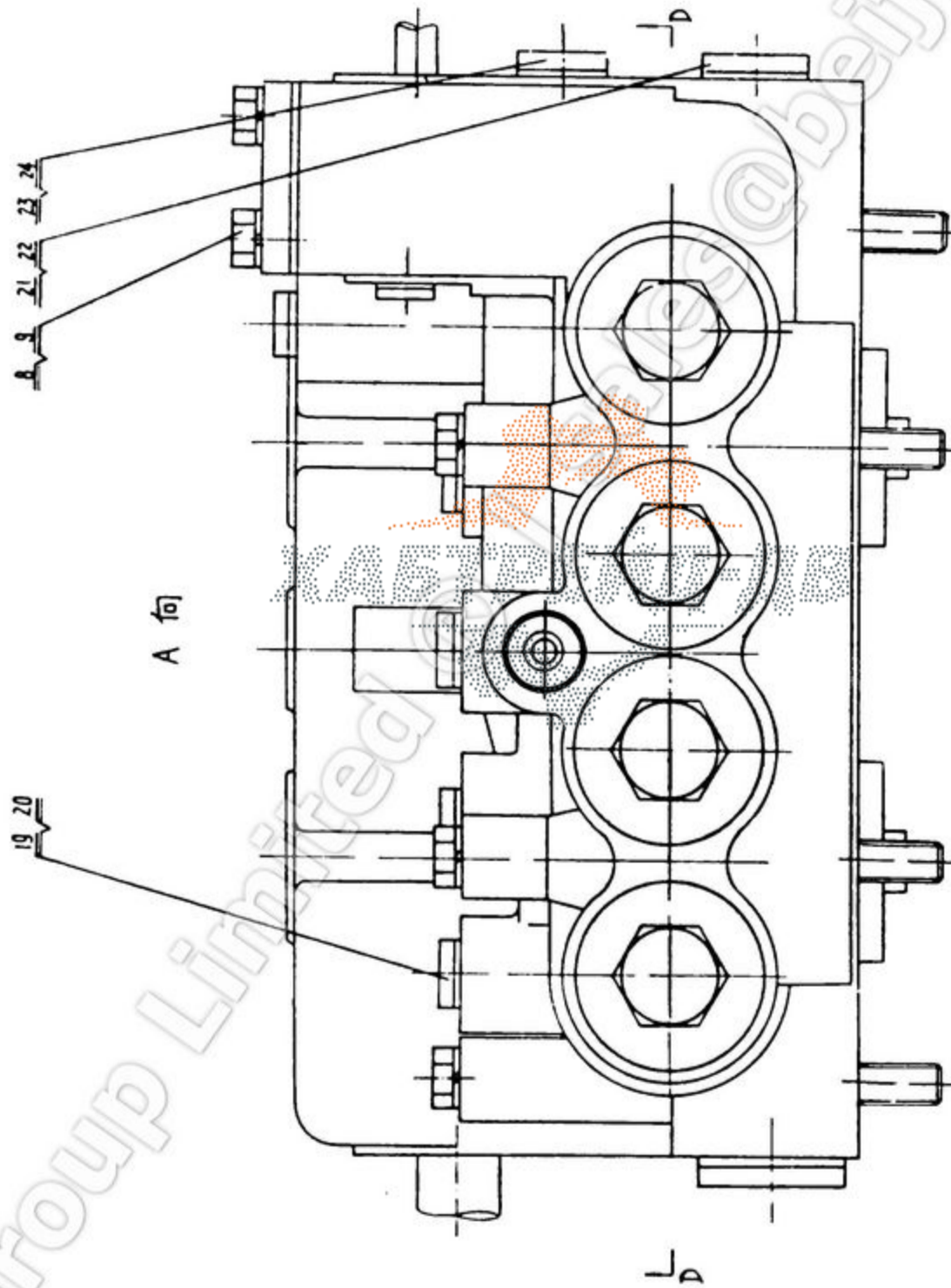

0T12200 转向制动阀 STEERING BRAKE VALVE

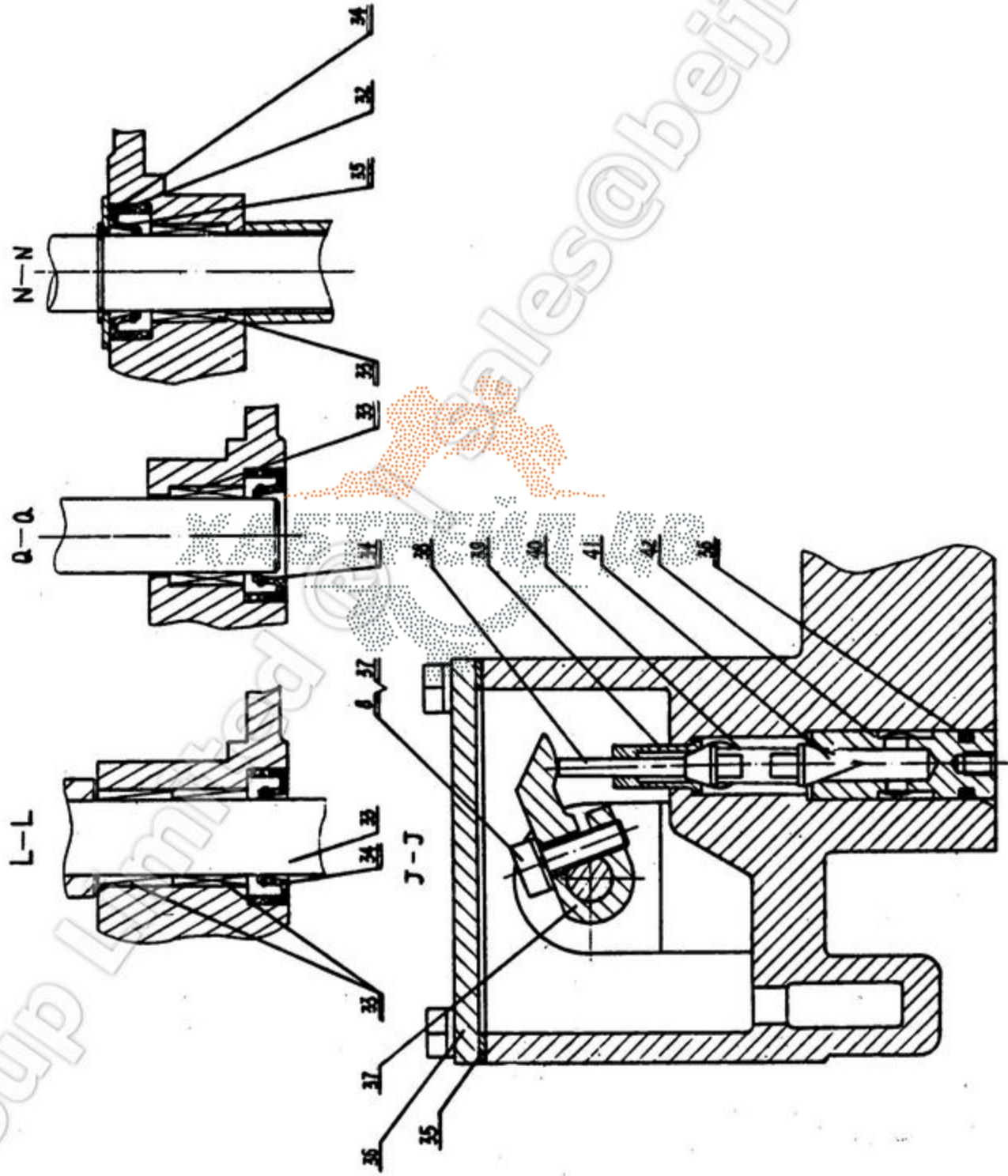

0T12200 转向制动阀
STEERING BRAKE VALVE

序号 NO.	代 号 PART NO.	名 称 NAME	数量 Q' TY	备注 REMARK
1	0T12201	阀体	1	
2	0T12202	密封垫	1	
3	0T12203	盖板	1	
4	0T12204	转向压头	2	
5	0T12205	挡板	1	
6	0T12206	停车制动施力轴	1	
7	0T12207	弹簧座	4	
8	0T12208	调整垫	4 组	
9	0T12209	转向调压弹簧	2	
10	0T12210	制动调压弹簧	2	
11	0T12211	转向阀杆	2	
12	0T12212	制动阀杆	2	
13	0T12213	柱塞座	4	
14	0T12214	弹簧	4	
15	0T12215	调整垫	4 组	
16	0T12216	转向操纵弹簧	2	
17	0T12217	制动操纵弹簧	2	
18	0T12218	转向操纵套	2	
19	0T12219	挡板	4	
20	0T12220	制动操纵套	2	
21	0T12286	螺栓	1	
22	0T12222	隔套	1	
23	0T12277	制动压头	1	
24	0T12279	板簧	2	
25	0T12225	压板	2	
26	0T12226	压板	2	
27	0T12227	板簧座	2	
28	0T12228	滚轮	6	
29	0T12229	销轴	3	
30	0T12282	销轴	2	
31	0T12288	紧固铁丝 $\varnothing 1.5 \times 60$	3	
32	0T12232	隔板	1	

0T12200 转向制动阀
STEERING BRAKE VALVE

序号 NO.	代 号 PART NO.	名 称 NAME	数量 Q'TY	备注 REMARK
33	0T12285	转向轴	2	
34	0T12284	制动轴	1	
35	0T12235	密封垫	1	
36	0T12236	盖板	1	
37	0T12237	压头	1	
38	0T12238	上锥阀芯	1	
39	0T12239	上锥阀座	1	
40	0T12240	弹簧	1	
41	0T12241	下锥阀芯	1	
42	0T12242	下锥阀座	1	
43	0T12287	紧定螺钉	3	
1	JB1001—77	螺塞 M14×1.5	2	
2	JB982—77	垫圈 14	2	
3	JB1001—77	螺塞 M27×2	3	
4	JB982—77	垫圈 27	3	
5	GB5782—86	螺栓 M12×120	4	
6	GB93—87	垫圈 12	4	
7	GB1099—79	键 5×19	6	
8	GB93—87	垫圈 8	18	
9	GB5782—86	螺栓 M8×20	14	
10	GB1099—79	键 3×16	1	
11	GB894.2—86	挡圈 12	1	
12	HG4-335-66	Y形密封圈 12×20	1	
13	GB290—89	轴承 HK121610	1	
14	GB290—89	轴承 BK121610	1	
15	JB982—77	垫圈 36	4	
16	GB893.2—86	挡圈 12	4	
17	GB308—77	钢球 Ø8	4	
18				
19	JB1000—77	螺塞 10×1	5	
20	JB982—77	垫圈 10	5	

0T12200 转向制动阀
STEERING BRAKE VALVE

序号 NO.	代 号 PART NO.	名 称 NAME	数量 Q' TY	备注 REMARK
21	JB1001-77	螺塞 M18×1.5	1	SCREW M18×1.5
22	JB982-77	垫圈 18	1	WASHER 18
23	JB1001-77	螺塞 16×1.5	1	SCREW PLUG 16×1.5
24	GB982-77	垫圈 16	1	WASHER 16
26	GB3452.1-82	O形密封圈 33.5×3.55	2	O-SEAL RING 33.5×3.55
27	GB5782-86	螺栓 M18×25	2	BOLT M18×25
28	GB5782-86	螺栓 M8×40	2	BOLT M8×40
29	JB982-77	垫圈 8	2	WASHER 8
30	GB119-86	销 B6×20	4	PIN B6×20
31	GB894.2-86	挡圈 8	5	RETAINER 8
33	GB290-89	滚针轴承 HK202614	6	NEEDLE HK202614
34	HG4-692-67	油封 PD20×35×10	4	OIL-SEAL PD20×35×10
35	GB894.2-86	挡圈 20	1	RETAINER 20
36	GB3452.1-82	O形密封圈 13.2×2.65	1	O-SEAL RING 13.2×2.65
38	GB895.2-86	挡圈 10	4	RETAINER 10

1T12100 变速箱控制阀总成
 TRANSMISSION CONTROL VALVE ASSEM.

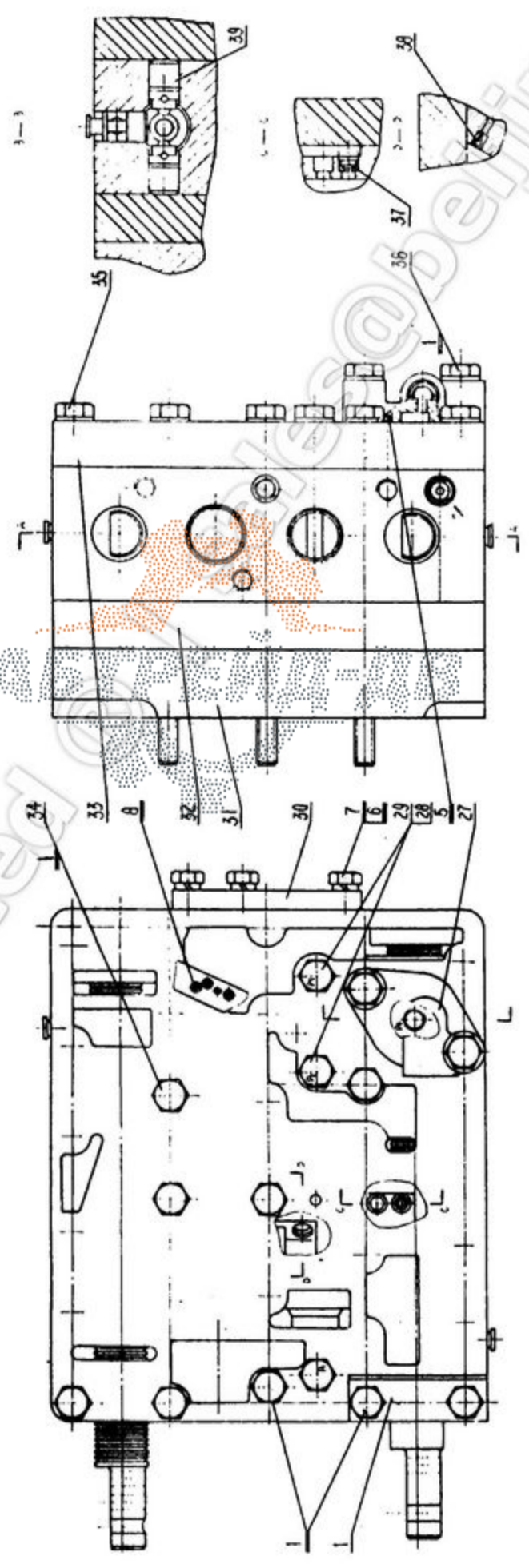

1T12100 变速箱控制阀总成
TRANSMISSION CONTROL VALVE ASSEM.

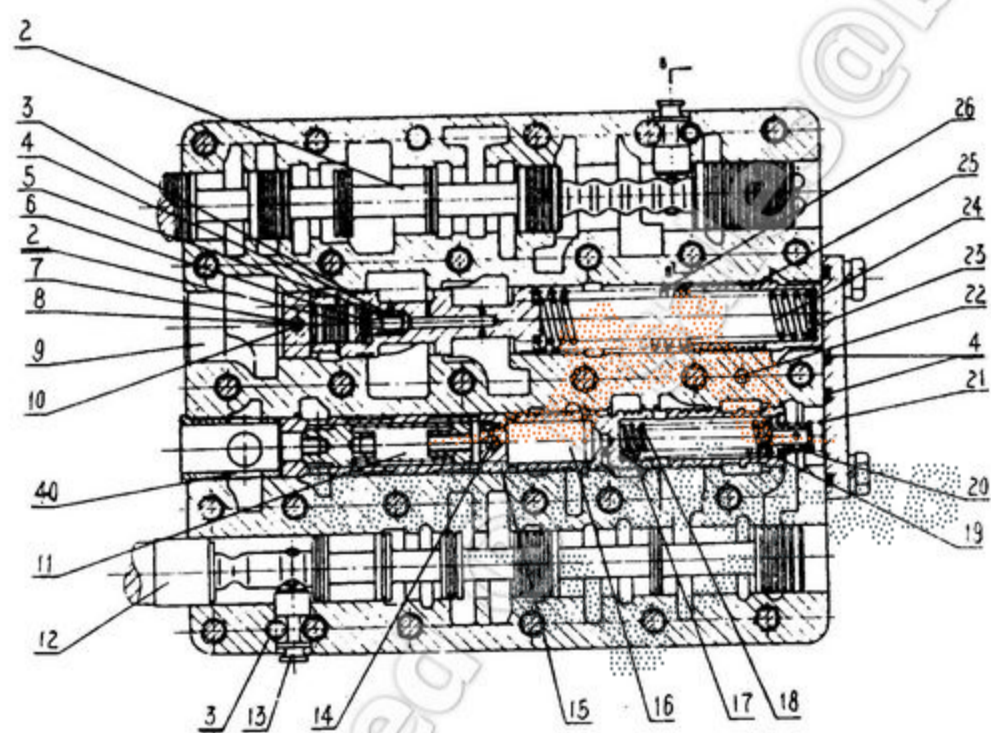

1T12100 变速箱控制阀总成

TRANSMISSION CONTROL VALVE ASSEM.

序号 NO.	代 号 PART NO.	名 称 NAME	数量 Q' TY	备注 REMARK
1	0T12151	测压管支板	1	
2	0T12152	变速杆	1	
3	0T12153	调压阀杆	1	
4	0T12154	单向阀堵	1	
5	0T12155	小弹簧	1	
6	0T12156	弹簧座	1	
7	0T12157	柱塞	1	
8	0T12158	挡块	1	
9	0T12159	变速阀体	1	
10	0T12160	销	1	
11	0T12290	溢流阀	1	
12	0T12162	换向杆	1	
13	0T12163	限位器	2	
14	0T12164	销	1	
15	0T12165	隔块	1	
16	0T12166	保险阀杆	1	
17	0T12167	保险阀细弹簧	1	
18	0T12168	保险阀粗弹簧	1	
19	0T12169	孔用卡环	1	
20	0T12170	弹簧座	1	
21	0T12171	保险小弹簧	1	
22	0T12172	节流元件	1	
23	0T12176	调整垫	1 组	
24	0T12177	调压细弹簧	1	
25	0T12178	调压套	1	
26	0T12179	调压粗弹簧	1	
27	0T12180	测压弯头	1	
28	0A10053	油塞	3	
29	0A09017	密封垫	3	
30	0T12181	端盖	1	
31	1T12101	分油座	1	
32	1T12102	中隔板	1	

1T12100 变速箱控制阀总成
TRANSMISSION CONTROL VALVE ASSEM.

序号 NO.	代 号 PART NO.	名 称 NAME	数量 Q' TY	备注 REMARK
33	1T12103	上盖板	1	
34	1T12104	螺栓	4	
35	1T12105	螺栓	24	
36	1T12106	螺栓	2	
37	0T12185	节流套	1	
38	0T12191	节流套	1	
39	0T12186	定位器	4	
40	0T12295	顶套	1	
1	GB97.1-85	垫圈 10	30	
2	GB893.1-86	挡圈 16	1	
3	GB897-86	销 8×65	2	
4	GB3452.1-82	O 型密封圈 32.5×3.55	2	
5	GB3452.1-82	O 型密封圈 28×3.55	1	
6	GB5783-86	螺栓 M8×25	3	
7	GB93-87	垫圈 8	3	
8	GB77-85	螺钉 M4×8	3	

0T12192 顺序阀 SEQUENCE VALVE

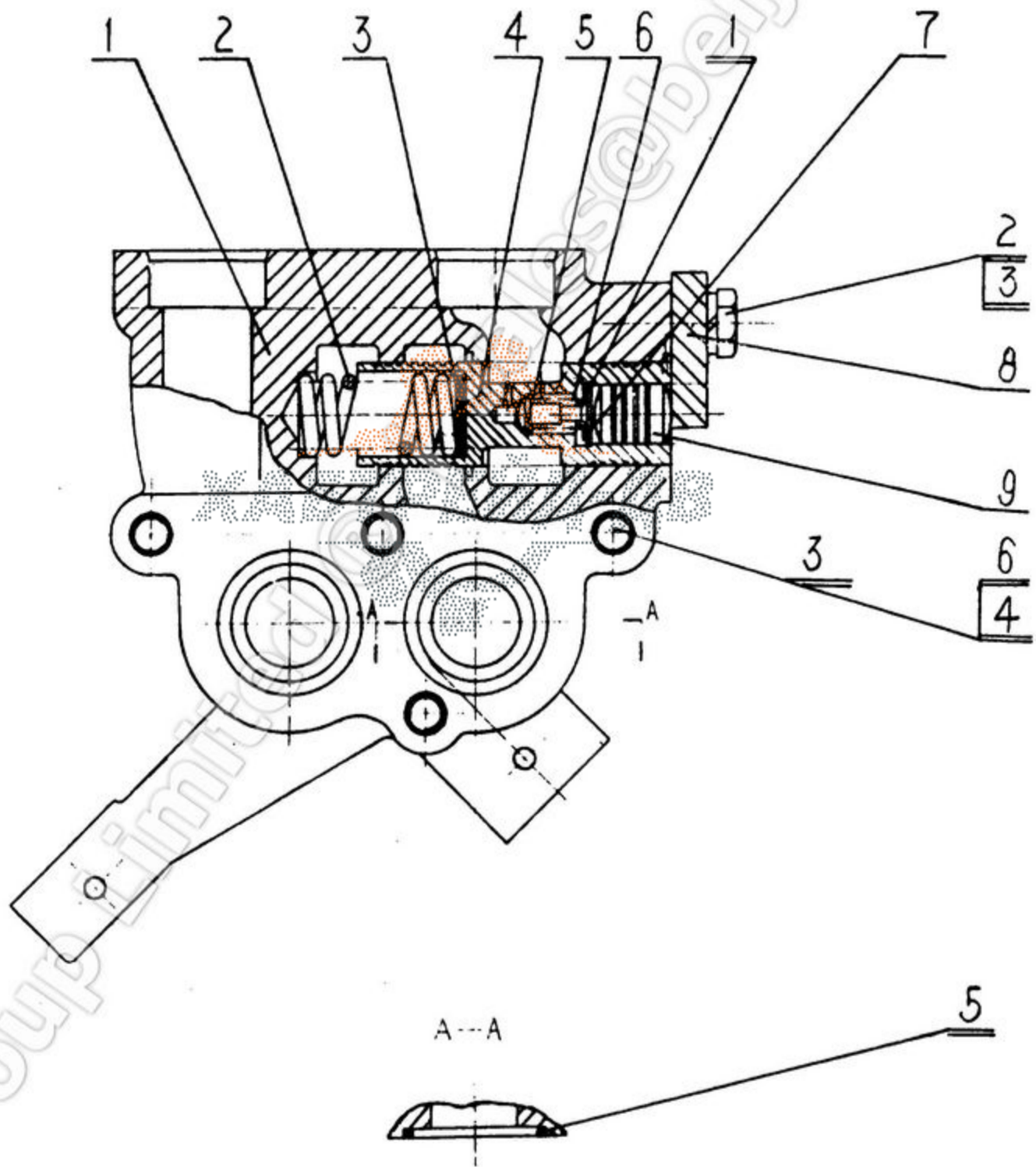

0T12192 顺序阀 SEQUENCE VALVE

序号 NO.	代 号 PART NO.	名 称 NAME	数量 Q' TY	备注 REMARK
1	0T12193	顺序阀体	1	
2	0T12194	弹簧	1	
3	0T12176	调整垫	1组	
4	0T12195	顺序阀杆	1	
5	0T12154	单向阀堵	1	
6	0T12155	小弹簧	1	
7	0T12156	弹簧座	1	
8	0T12196	挡板	1	
9	0T12157	柱塞	1	
1	GB893.1-86	挡圈 16	1	
2	GB5783-86	螺栓 M10×30	2	
3	GB93-87	垫圈 10	2	
4	GB5782-86	螺栓 M10×75	4	
5	GB3452.1-82	O型密封圈 32.5×3.55	2	
6	GB97.1-85	垫圈 10	1	

1T12055 细滤器总成 SECONDARY FILTER

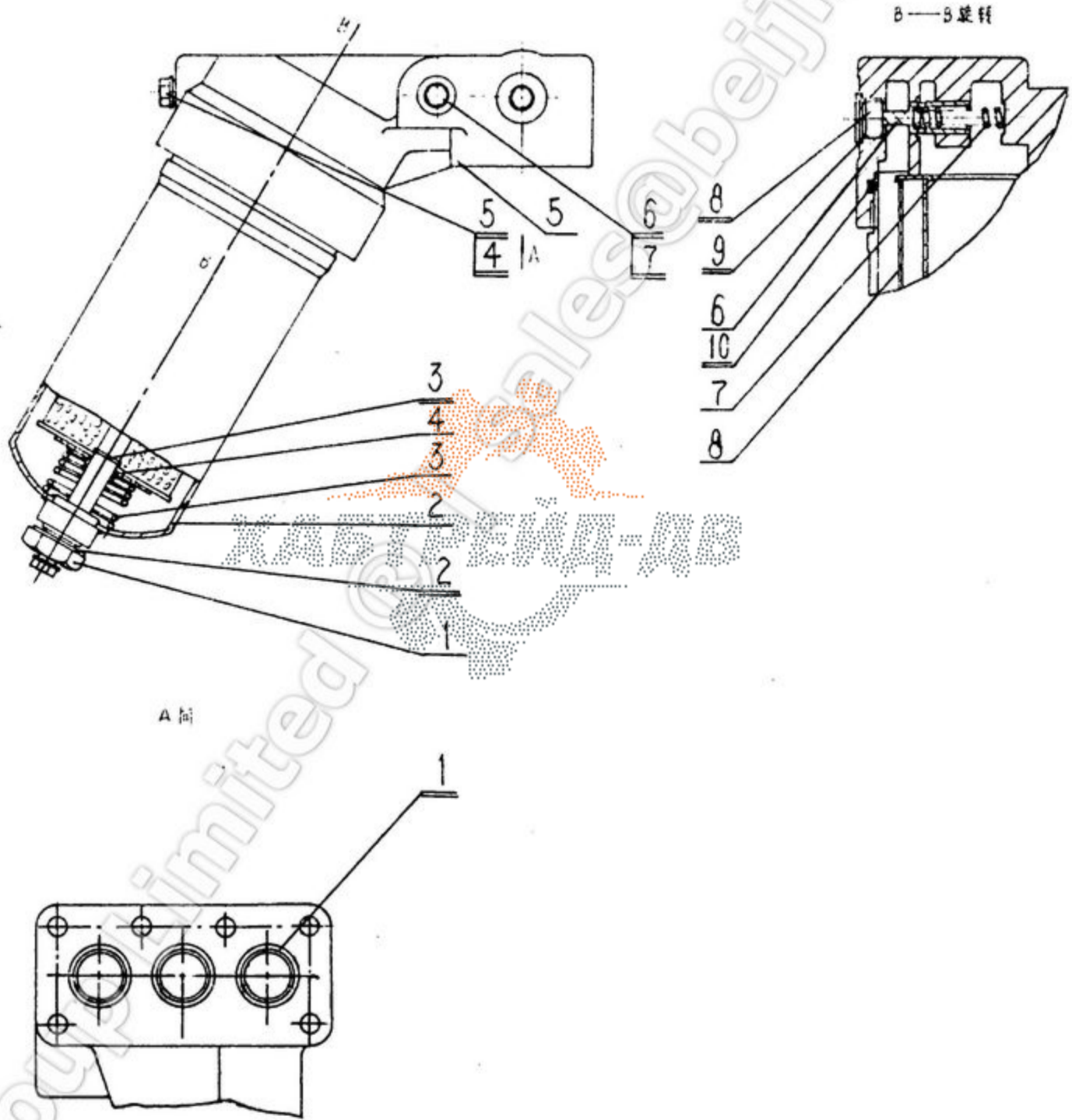

1T12055 细滤器总成 SECONDARY FILTER

序号 NO.	代 号 PART NO.	名 称 NAME	数量 Q' TY	备注 REMARK
1	1T12056	支杆	1	
2	1T12057	滤油器筒	1	
3	0A19076	大弹簧	1	
4	1T12061	弹簧座	1	
5	1T12062	底座	1	
6	1T12063	安全阀杆	1	
7	1T12064	安全阀弹簧	1	
8	1T12065	滤芯 YLX—89	1	
		YLX—819		
1	GB3452. 1-82	O 形圈 33.5×3.55	3	
2	JB982—77	垫圈 24	1	
3	GB894. 1—86	挡圈 18	1	
4	JB1000—77	螺塞 M10×1	2	
5	JB982—77	垫圈 10	2	
6	JB1000—77	螺塞 M20×1.5	1	
7	JB982—77	垫圈 20	1	
8	JB1000—77	螺塞 M27×2	2	
9	JB982—77	垫圈 27	2	
10	GB3452. 1-82	O 形圈 122×7	1	

1T12080 粗滤器总成 PRIMARY FILTER

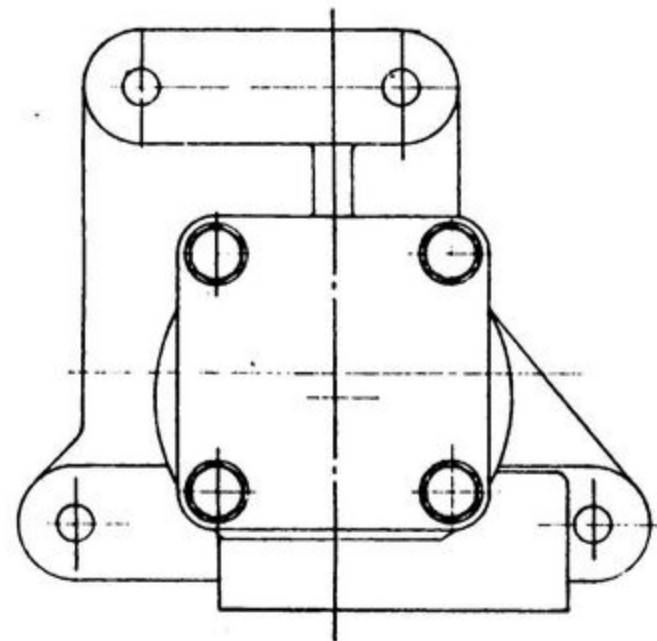
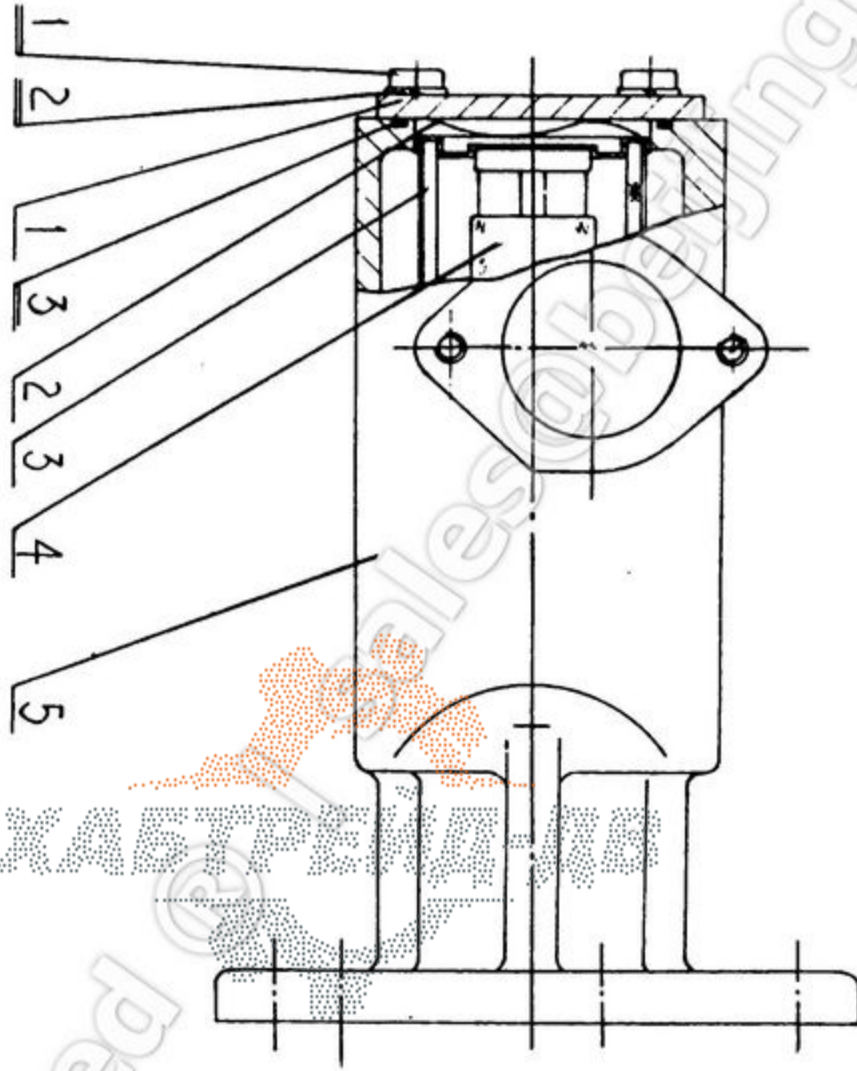

1T12080 粗滤器总成 PRIMARY FILTER

序号 NO.	代 号 PART NO.	名 称 NAME	数量 Q' TY	备注 REMARK
1	1T12114	顶盖 TOP COVER	1	
2	1B01506	波形垫 GASKET	1	
3	1B01514	进口滤芯 FILTER ELEMENT , INLET	1	
4	1B01509	磁滤芯管 PIPE, MAGNET ELEMENT	1	
5	1T12081	滤筒 FILTER CYLINDER	1	
1	GB5783—86	螺栓 M10×30 BOLT M10×30	4	
2	GB93—87	垫圈 10 WASHER 10	4	
3	GB3452. 1-82	O 形圈 95×3. 55 O—RING 95×3. 55	2	

1T13000 铲刀液压控制系统
IMPLEMENT HYDRAULIC SYSTEM

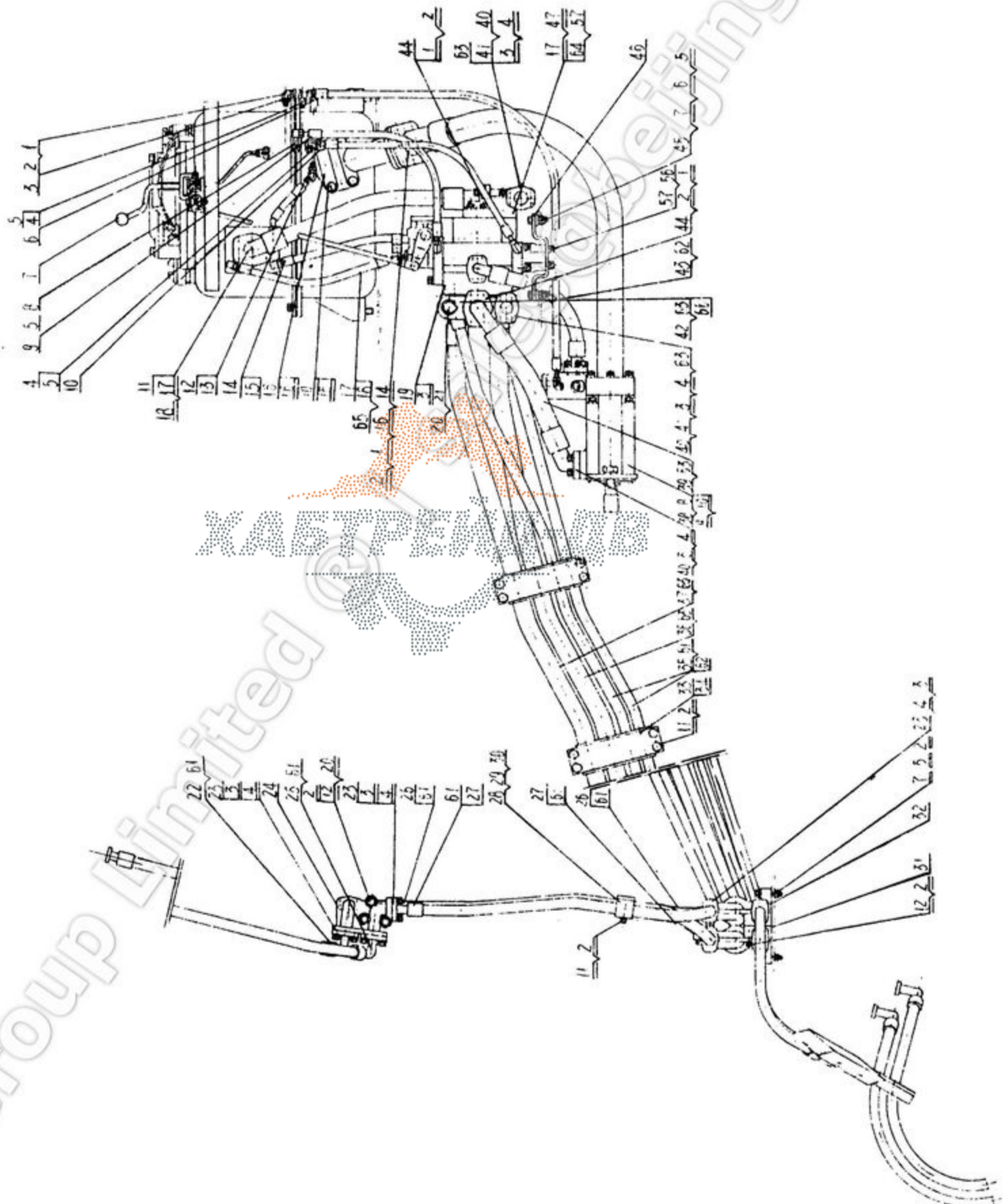

1T13000 铲刀液压控制系统
IMPLEMENT HYDRAULIC SYSTEM

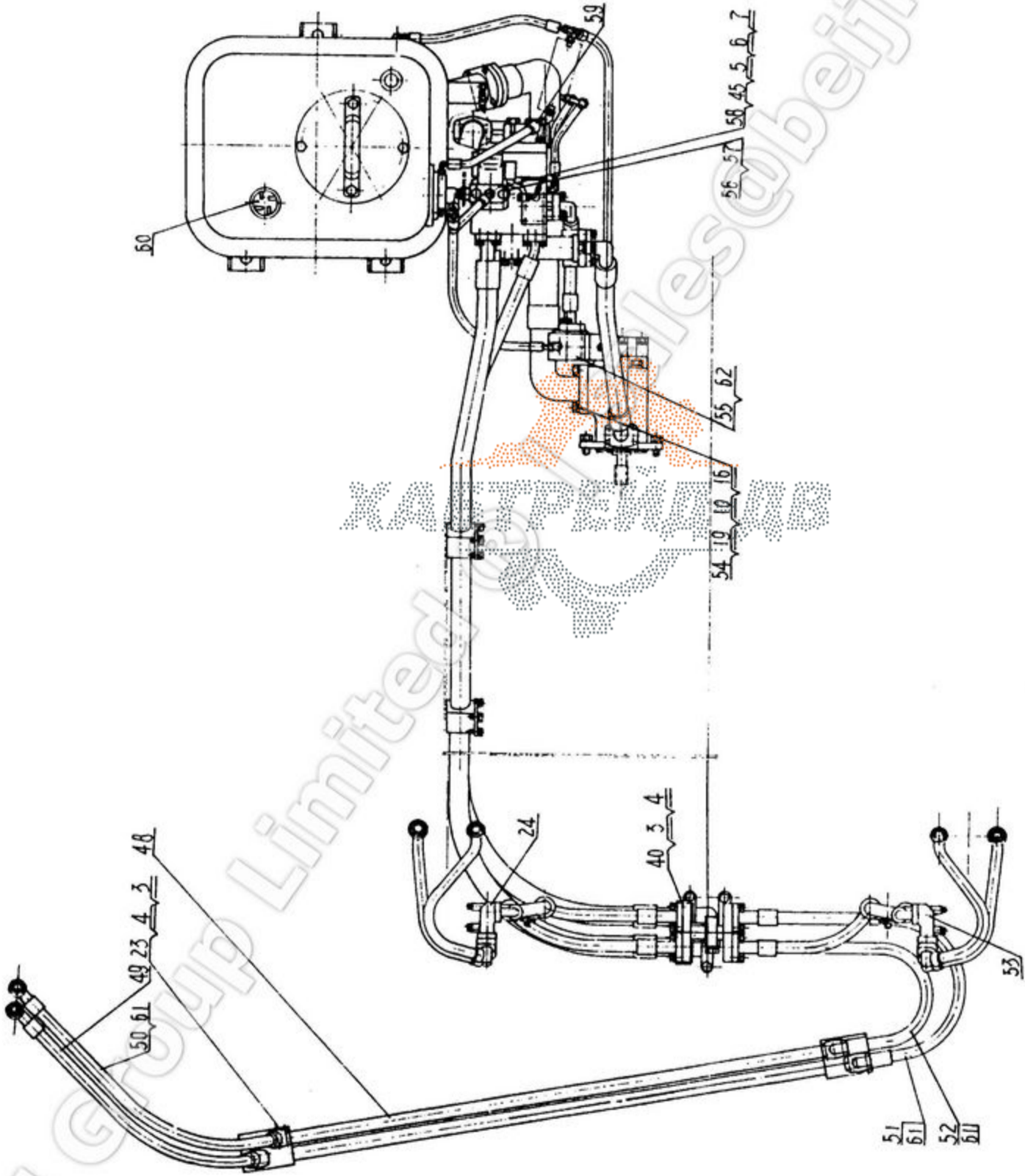

1T13000 铲刀液压控制系统
IMPLEMENT HYDRAULIC SYSTEM

序号 NO.	代 号 PART NO.	名 称 NAME	数量 Q' TY	备注 REMARK
1	1T13030	直角弯头组件	1	
2	1B10106	O形密封圈	1	
3	1T13047	液控泄油软管	1	
4	1B01524	直角弯头组件	2	
5	1B01382	O形圈	4	
6	1T13045	液控泵油软管	4	
7	1T13100	铲刀操纵组件	1	
8	1T13034	长直角弯头组件	1	
9	1T13036	阀上液控软管	1	
10	1T13038	阀下液控软管	1	
11	1T13040	回油软管	1	
12	1B01328	O形圈	1	
13	1B24041	弯头组件	1	
14	1B01406	夹子	1	
15	1T13051	顺序阀泄油软管	1	
16	1T13001	吸油弯头	1	
17	1T13053	主阀泄油软管	1	
18	1T13059	吸油管	1	
19	1T13160	铲刀控制阀	1	
20	1T13098	测压接头	2	
21	1T13002	接头座	1	
22	1T13069	杆腔软管	1	
23	0T13027	压盖	40	
24	1T13003	右分油座	1	
25	1T13073	底腔软管	2	
26	1T13075	中油管(一)	2	
27	1T13077	中油管(二)	2	
28	0T12010	管夹	4	

1T13000 铲刀液压控制系统
IMPLEMENT HYDRAVLEC SYSTEM

序号 NO.	代 号 PART NO.	名 称 NAME	数量 Q' TY	备注 REMARK
29	0T12011	管夹	4	
30	1T13004	胶套	4	
31	1T13005	前分油座	1	
32	1T13006	后分油座	1	
33	1T13007	压板	2	
34	1T13008	四孔胶套	2	
35	1T13079	侧倾油管	2	
36	1T13082	杆腔油管	1	
37	1T13120	底腔油管	1	
38	1T13150	双联叶片泵 YBVQ—125/63	1	
39	1T13085	大泵油管	1	
40	1B01405	压盖	10	
41	1T13010	堵板	2	
42	1T13011	泵油四通	1	
43	1T13028	小泵油管	1	
44	0T13032	压盖	2	
45	0T13253	缓冲块	3	
46	1T13012	托板	1	
47	1T13013	回油三通	1	
48	1T13056	硬管组件	1	
49	1T13089	侧倾杆腔前软管	1	
50	1T13092	侧倾底腔前软管	1	
51	1T13094	侧倾杆腔后软管	1	
52	1T13096	侧倾底腔后软管	1	
53	1T13014	左分油座	1	
54	1T13015	压盖	2	
55	1T13130	顺序阀组件	1	
56	1B12005	螺栓	2	
57	1B01253	垫圈	2	
58	1T13016	弯板	1	

1T13000 铲刀液压控制系统
IMPLEMENT HYDRAVLEC SYSTEM

序号 NO.	代 号 PART NO.	名 称 NAME	数量 Q'TY	备注 REMARK
59	1T13064	液控回油管	1	
60	1T13300	油箱	1	
61	1B01415	O形圈	26	
62	1B08057	O形圈	5	
63	1B01418	O形圈	9	
64	1B03637	螺栓	2	
65	1T13017	压盖	2	
66	1T13099	螺栓	4	
1	GB5282—86	螺栓 M12×40	12	
2	GB97.1—85	垫圈 12	35	
3	GB5782—86	螺栓 M10×35	100	
4	GB97.1—85	垫圈 10	100	
5	GB5782—86	螺栓 M12×50	6	
6	GB96—85	垫圈 12	3	
7	GB6170—86	螺母 M12	6	
8	GB3452.1-82	O形圈 128×3.55	1	
9	GB5782—86	螺栓 M16×45	2	
10	GB97.1—85	垫圈 16	10	
11	GB5783—86	螺栓 M12×25	10	
12	GB5782—86	螺栓 M12×60	6	
13	JB982—77	垫圈 36	1	
14	GB3452.1-86	O形圈 67×3.55	1	
15	GB5782—86	螺栓 M16×110	4	
16	GB3452.1-82	O形圈 82.5×3.55	2	
17	GB3452.1-82	O形圈 47.5×3.55	2	
18	GB3452.1-82	O形圈 58×3.55	1	
19	GB5782—86	螺栓 M16×50	4	
20	GB5782—86	螺栓 M12×80	2	

1T13100 工作装置操纵 IMPLEMENT CONTROL

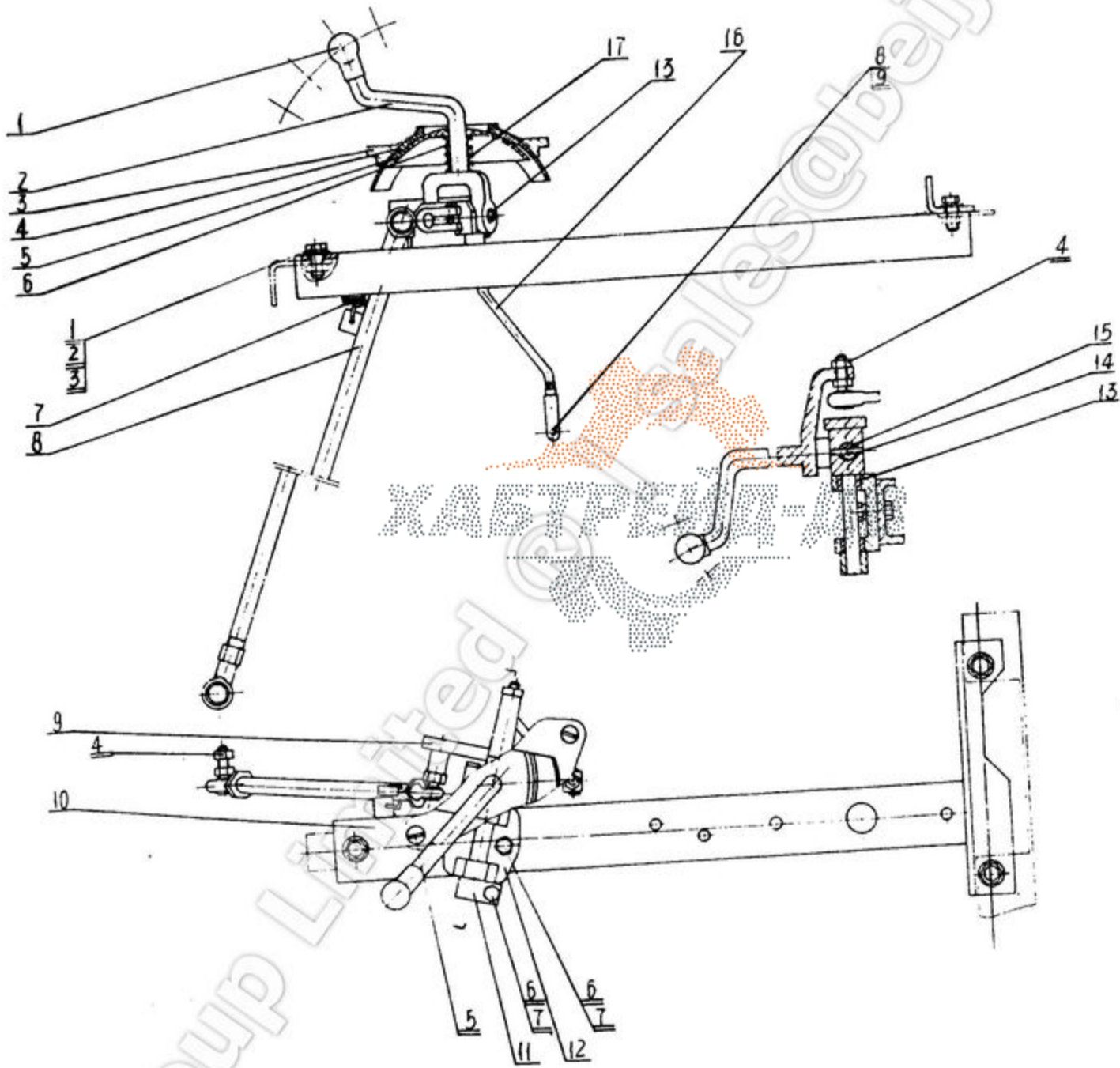

1T13100 工作装置操纵 IMPLEMENT CONTROL

序号 NO.	代 号 PART NO.	名 称 NAME	数量 Q/TY	备注 REMARK
1	0A03042	手柄	1	
2	1T13103	摆架组件	1	
3	0F23003	盖	1	
4	0F23004	外罩	1	
5	0F23005	内罩	1	
6	1B09059	弹簧(一)	1	
7	1T13101	弹簧(二)	1	
8	1T13106	连杆(一)组件	1	
9	1T13111	联板组件	1	
10	1T13115	固定架	1	
11	0T31084	挡块	1	
12	0T13141	转轴座	1	
13	0A14035	小套	4	
14	0F23018	铁丝 $\varnothing 3 \times 35$	1	
15	0F23017	销轴	1	
16	1T13118	连杆(二)组件	1	
17	1T13102	护套	1	
1	GB5782—86	螺栓 M12×30	3	
2	GB93—87	垫圈 12	3	
3	GB97.1—85	垫圈 12	3	
4	GB6171—86	螺母 M10×1.25	2	
5	GB818—85	螺钉 M8×20	4	
6	GB5782—86	螺栓 M10×35	3	
7	GB93—87	垫圈 10	3	
8	GB882—86	销轴 6×22	1	
9	GB91—86	销 2×20	1	

1T13130 顺序阀组件 SEQUENCE VALVE GROUP

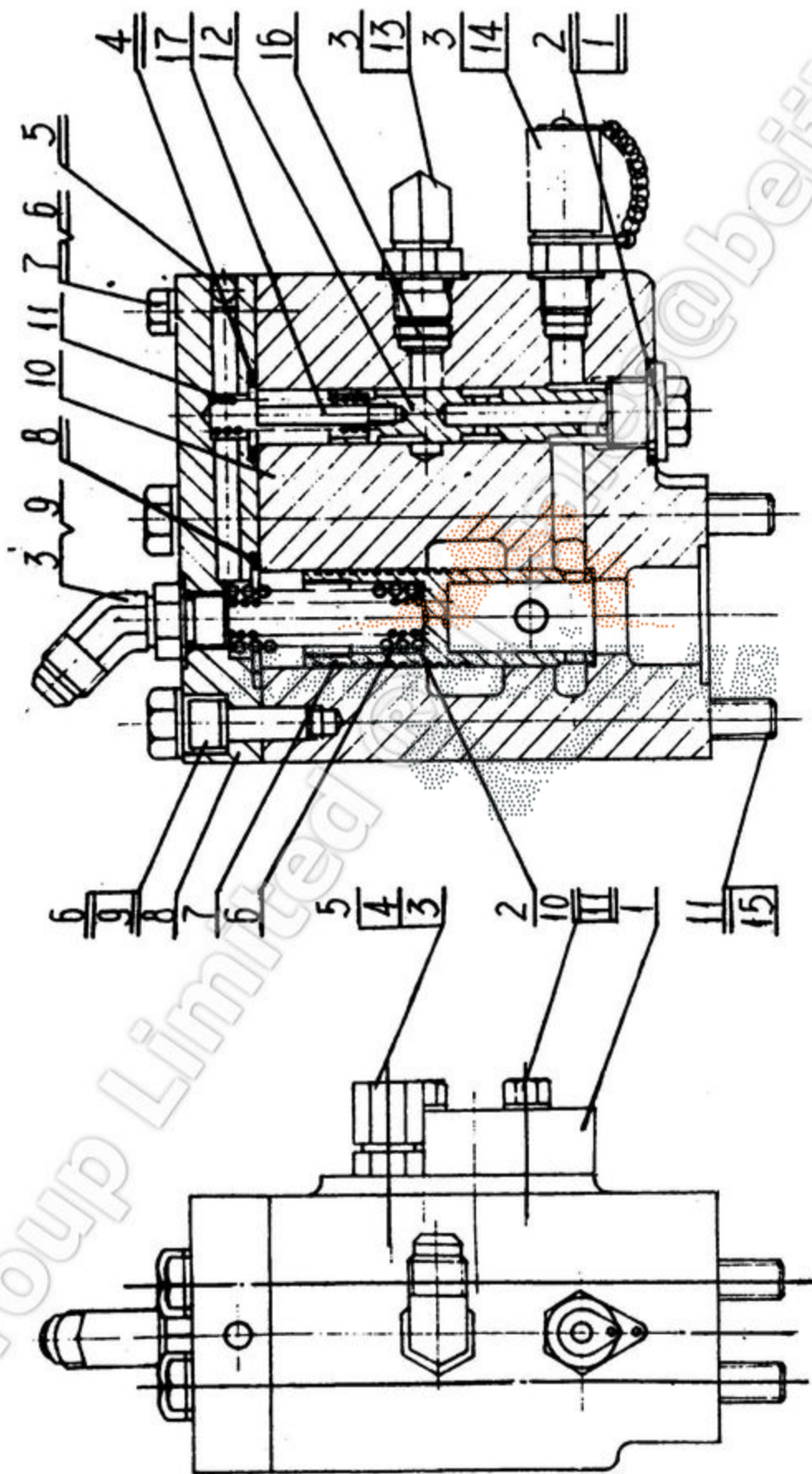

1T13130 顺序阀组件 SEQUENCE VALVE GROUP

序号 NO.	代 号 PART NO.	名 称 NAME	数量 Q'TY	备注 REMARK
1	0T13027	压盖	2	
2	1T13131	外簧	1	
3	1B01382	O形密封圈	3	
4	1T20103	直接头	1	
5	1B24033	堵盖	1	
6	1T13132	内簧	1	
7	1T13133	大阀杆	1	
8	1T13134	盖板	1	
9	1B01528	弯头组件	1	
10	1T13135	阀体	1	
11	1T13136	小弹簧	1	
12	1T13137	小阀杆	1	
13	1B01524	直角弯头组件	1	
14	1T13098	测压接头组件	1	
15	1T13138	螺栓 M10×150	4	
16	1T13139	节流堵	1	
17	1T13140	顶杆	1	
1	JB1000—77	螺塞 M18×1.5	1	
2	JB982—77	垫圈 18	1	
3	JB982—7	垫圈 12	1	
4	GB3452.1-82	O形圈 18×2.65	1	
5	GB308—77	钢球 6	1	
6	GB93—86	垫圈 6	3	
7	GB5782—86	螺栓 M6×35	2	
8	GB3452.1-82	O形密封圈 30×2.65	1	
9	GB70—85	螺钉 M6×20	1	
10	GB5782—86	螺栓 M10×30	4	
11	GB93—86	垫圈 10	8	

1T13160 铲刀控制阀 BULLDOZER CONTROL VALVE

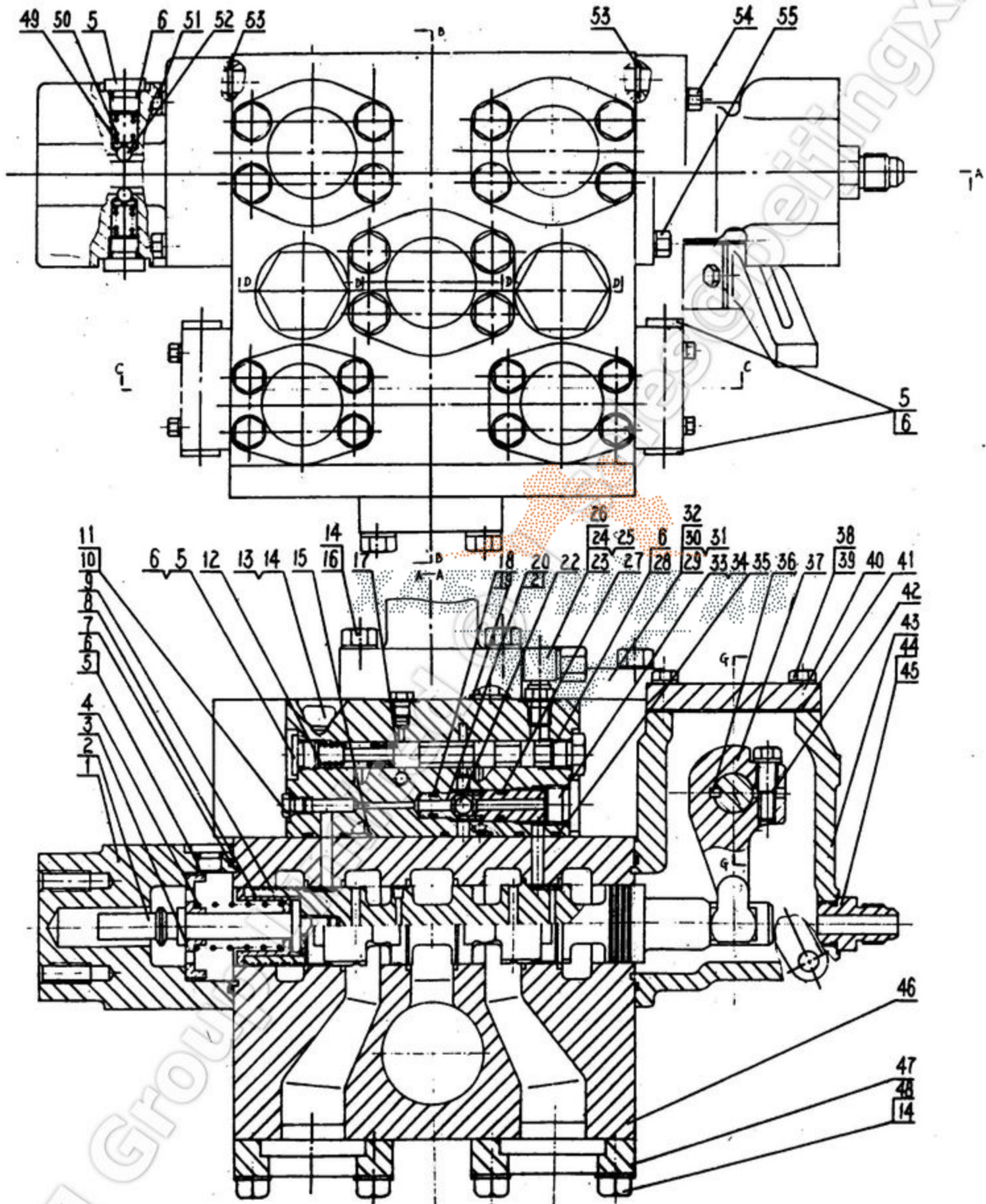

1T13160 铲刀控制阀 BULLDOZER CONTROL VALVE

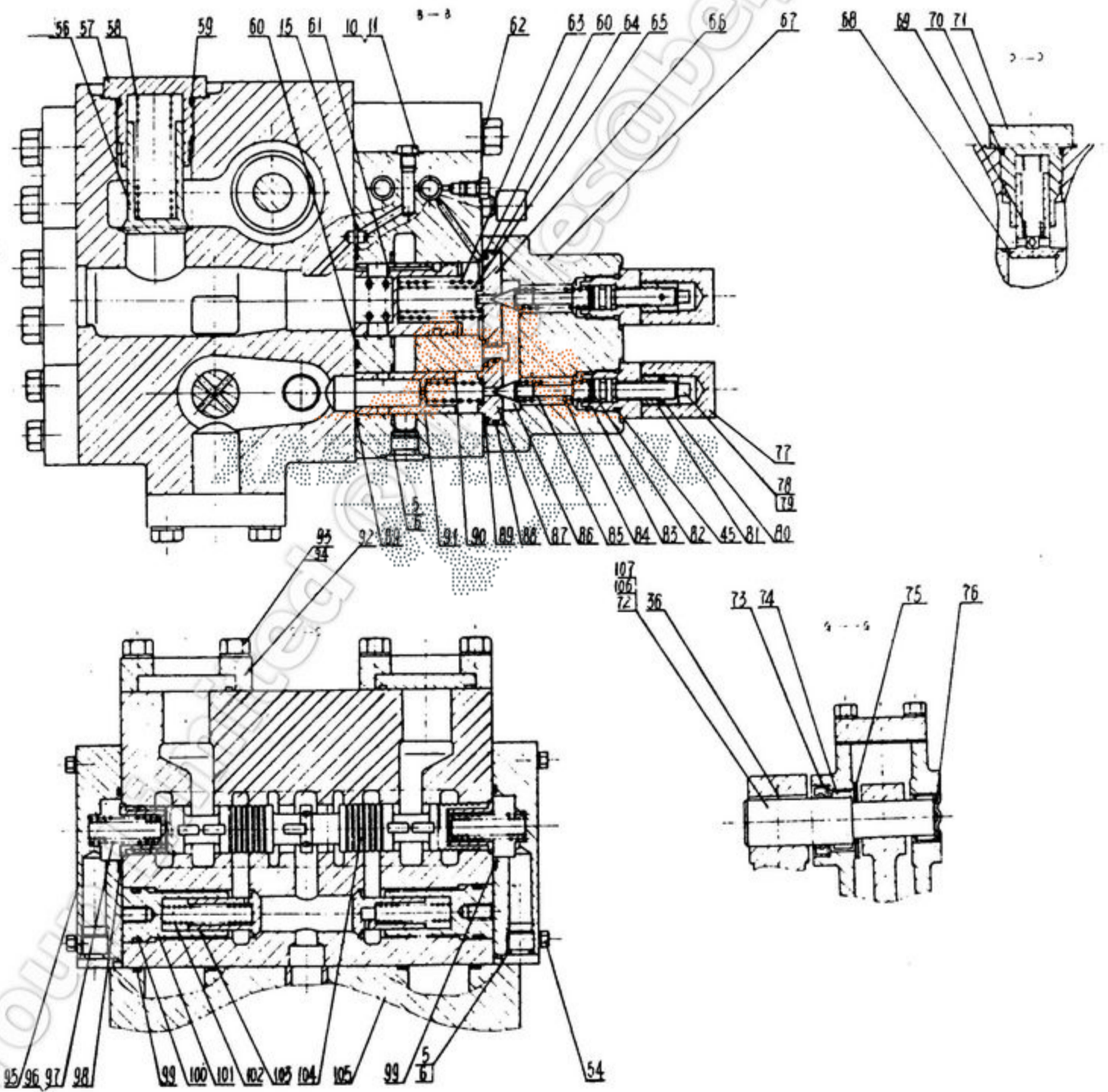

1T13160 铲刀控制阀 BULLDOZER CONTROL VALVE

序号 NO.	代 号 PART NO.	名 称 NAME	数量 Q' TY	备注 REMARK
1	1T13161	定位罩	1	
2	1T13162	定位杆	1	
3	1T13163	限位座	2	
4	1T13164	回位弹簧	1	
5	1B09153	油塞	13	
6	1B01382	O 形圈	13	
7	1T13165	O 形圈	4	
8	1T13166	弹簧座	1	
9	1T13167	提升阀杆	1	
10	1T13168	螺塞	3	
11	1T13169	O 形圈	3	
12	1T13170	控制弹簧	1	
13	1T13171	螺栓	1	
14	1B01407	垫圈	13	
15	1T13172	O 形圈	3	
14	1B01407	垫圈	13	
15	1T13172	O 形圈	3	
16	1B01412	螺栓	5	
17	1T13173	选择阀杆	1	
18	1T13174	O 形圈	1	
19	1T13175	O 形圈	1	
20	1T13176	小棱阀体	1	
21	1T13177	大棱阀体	1	
22	GB308—77	钢球 3/8"	1	
23	1B24033	堵盖	1	

1T13160 铲刀控制阀 BULLDOZER CONTROL VALVE

序号 NO.	代 号 PART NO.	名 称 NAME	数量 Q'TY	备注 REMARK
24	1T13178	接头体	1	
25	1B01429	O 形圈	1	
26	1B27033	弯头组件	1	
27	1T13179	O 形圈	1	
28	1T13180	油塞	1	
29	1T13181	盖板	1	
30	1B03358	螺栓	4	
31	1B01253	垫圈	4	
32	1B03570	O 形圈	2	
33	1B01327	油塞	1	
34	1B01328	O 形圈	1	
35	1T13182	O 形圈	3	
36	1T13183	半圆键	1	
37	1T13184	拔杆	1	
38	1B03033	螺栓	4	
39	1B03596	垫圈	4	
40	1T13185	盖板	1	
41	1T13186	垫	1	
42	1T13187	螺栓	1	
43	1T13188	护罩	1	
44	1T13189	接头体	1	
45	1B01393	O 形圈	3	
46	1T13190	阀体	1	
47	1B01405	压盖	6	

1T13160 铲刀控制阀 BULLDOZER CONTROL VALVE

序号 NO.	代 号 PART NO.	名 称 NAME	数量 Q' TY	备注 REMARK
48	1B09105	螺栓	12	
49	1T13191	压板	2	
50	1T13192	定位弹簧	2	
51	1B01409	螺栓	4	
52	GB308—77	钢球 9/32	2	
53	1T13193	O形圈	2	
54	1B24039	螺栓	9	
55	1B01064	螺栓	3	
56	1T13194	大锥阀芯	1	
57	1T13195	大锥阀体	1	
58	1T13196	弹簧	1	
59	1B09045	O形密封圈	1	
60	1T13197	O形密封圈	2	
61	1T13198	大工作阀芯	1	
62	1B09021	螺栓	4	
63	1T13199	外簧	1	
64	1T13200	O形密封圈	1	
65	1T13201	内簧	1	
66	1T13202	大锥阀座	1	
67	1T13203	先导阀体	1	
68	1T13204	补油锥阀芯	2	
69	1T13205	补油弹簧	2	
70	1B09197	O形密封圈	2	
71	1T13206	补油锥阀体	2	

1T13160 铲刀控制阀 BULLDOZER CONTROL VALVE

序号 NO.	代 号 PART NO.	名 称 NAME	数量 Q' TY	备注 REMARK
72	1T13207	操纵轴	1	
73	1B10088	油封	1	
74	1T13208	轴承	1	
75	1T13209	轴承	1	
76	1T13210	轴承	1	
77	1T13211	护套	2	
78	1T13212	调节杆	2	
79	1T13213	O形密封圈	2	
80	1T13214	开口弹簧销	2	
81	1T13215	背母	2	
82	1T13216	调整垫	2组	
83	1T13217	接头座	2	
84	1T13218	先导弹簧	2	
85	1T13219	支承柱	2	
86	1T13220	锥阀芯	2	
87	1T13221	小锥阀座	1	
88	1T13222	O形密封圈	1	
89	1B09197	O形密封圈	2	
90	1T13223	小工作弹簧	1	
91	1T13224	小工作阀芯	1	
92	1B01378	压盖	4	
93	1B01410	螺栓	8	
94	1B03003	垫圈	8	
95	1T13225	油板	2	
96	1T13226	外簧	2	

1T13160 铲刀控制阀 BULLDOZER CONTROL VALVE

序号 NO.	代 号 PART NO.	名 称 NAME	数量 Q' TY	备注 REMARK
97	1T13227	内簧	2	
98	1T13228	弹簧座	2	
99	1B01418	O形密封圈	4	
100	1T13229	O形密封圈	2	
101	1T13230	锥阀座	2	
102	1T13231	弹簧	2	
103	1T13232	小截止锥阀芯	2	
104	1T13233	侧倾阀杆	1	
105	1T13234	压力阀体	1	
106	1T13235	摇臂	1	
107	1B09012	螺栓	1	

1U1819—XG 推土铲控制阀 (外配套件)
 BULLDOZER CONTROL VALVE (PURCHASED PARTS)

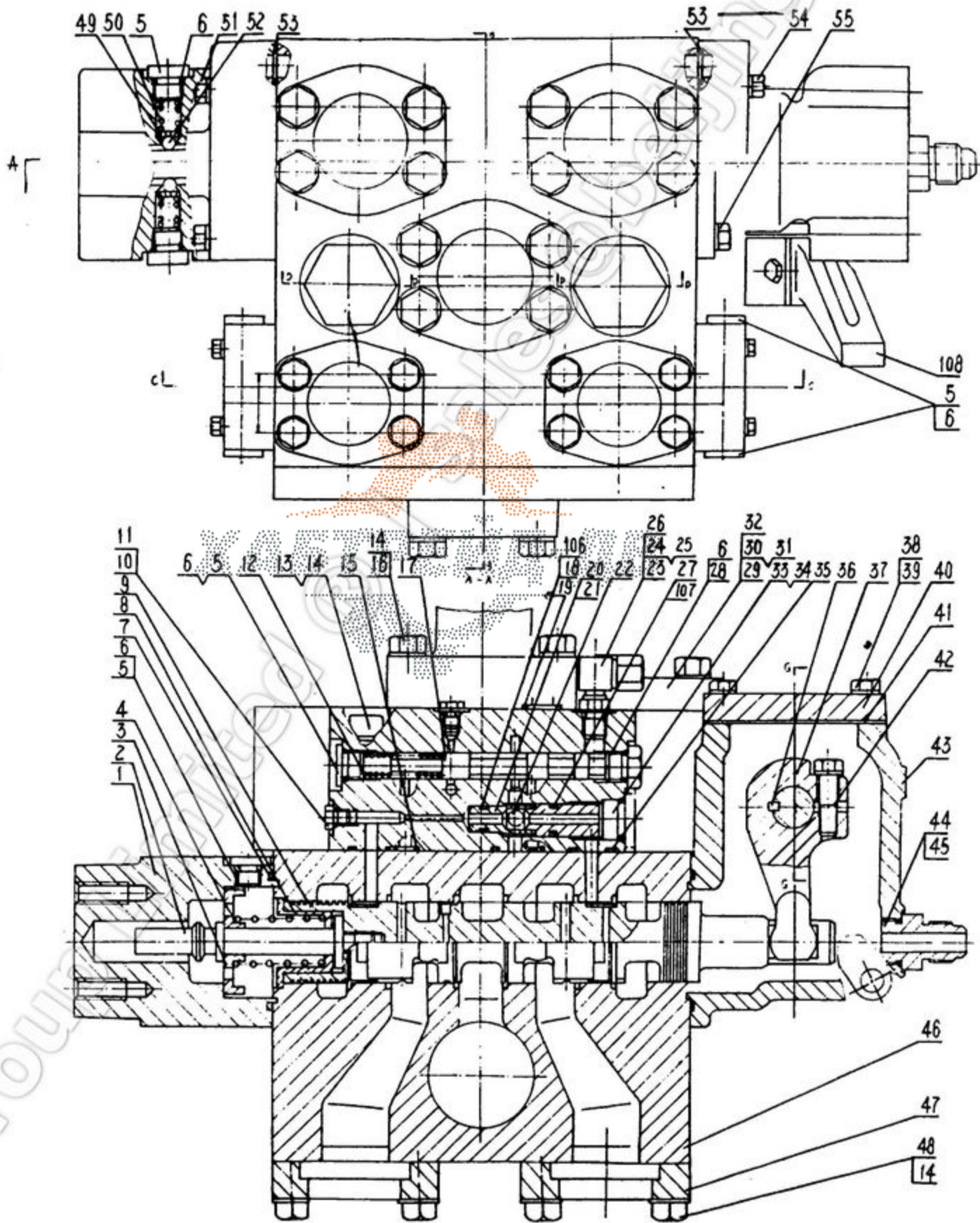

1U1819—XG 推土铲控制阀 (外配套件)
 BULLDOZER CONTROL VALVE (PURCHASED PARTS)

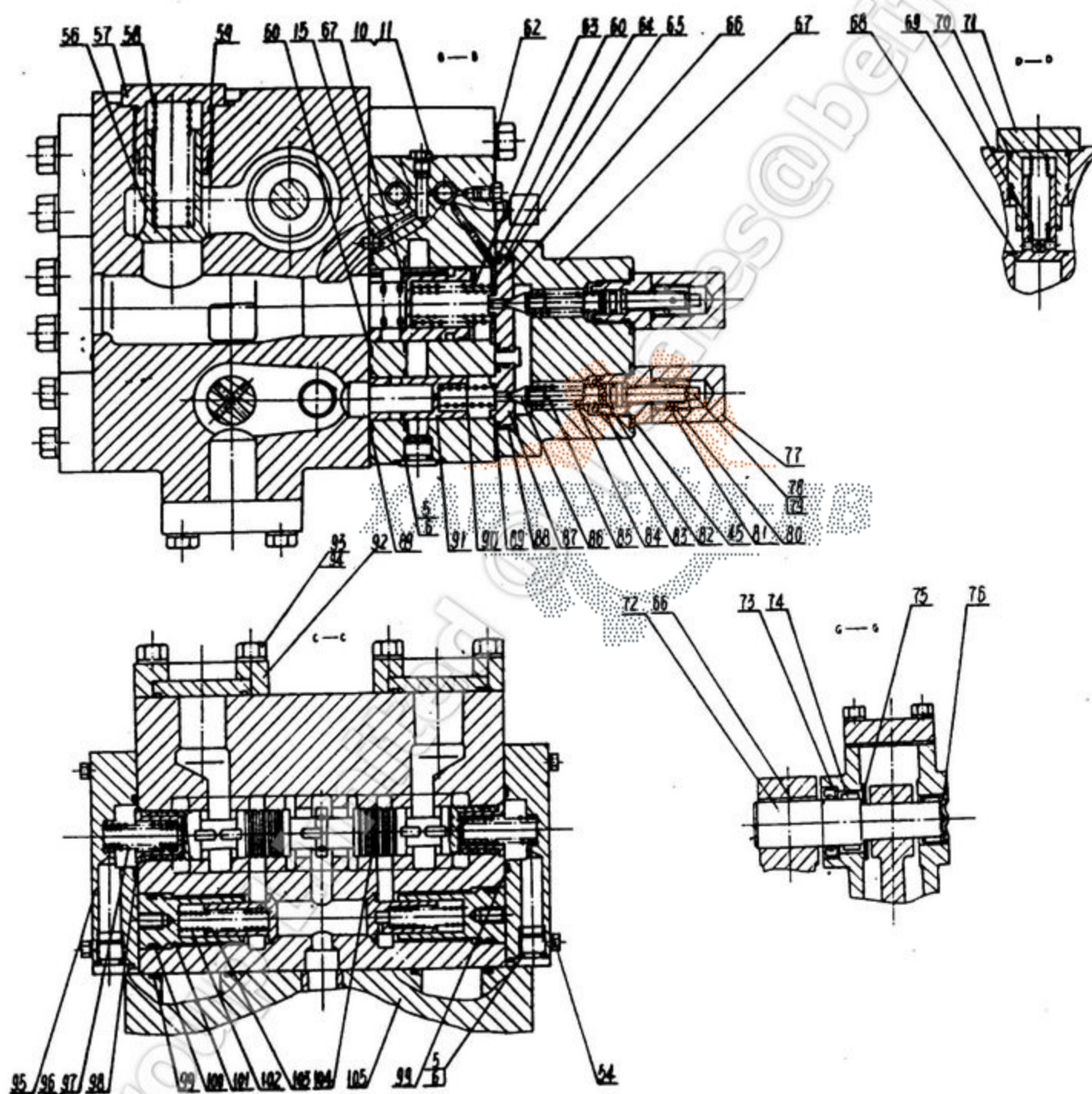

1U1819—XG 推土铲控制阀 (外配套件)

BULLDOZER CONTROL VALVE (PURCHASED PARTS)

序号 NO.	代 号 PART NO.	名 称 NAME	数量 Q' TY	备注 REMARK
1	8J7467	连接体	1	
2	3G5766	螺栓	1	
3	3G8148	定位套	2	
4	3G9182	弹簧	1	
5	9S8004	螺塞	13	
6	3J1907	O形圈	13	
7	1H8720	O形圈	4	
8	3G8149	定位套	1	
9	9T4360	滑阀	1	
10	9S4191	螺塞	3	
11	4J7533	O形圈	3	
12	9J5756	弹簧	1	
13	5P7892	螺栓	1	
14	5P8244	垫圈	13	
15	9J6491	密封圈	3	
16	0T0768	螺栓	5	
17	8J7430	阀杆	1	
18	336039	密封圈	1	
19	2M4453	O形圈	1	
20	IU2640	阀座套	1	
21	IU2641	阀座套	1	
22	GB308—77	钢球 3/8"	1	
24	3D3978	管接头	1	
25	3J7354	O形圈	1	

1U1819—XG 推土铲控制阀 (外配套件)

BULLDOZER CONTROL VALVE (PURCHASED PARTS)

序号 NO.	代 号 PART NO.	名 称 NAME	数量 Q' TY	备注 REMARK
26	6K9194	弯管接头	1	
27	8L2777	密封圈	1	
28	5P6719	螺塞	1	
29	7J1592	盖板	2	
30	0S1621	螺栓	4	
31	5P8245	垫圈	4	
32	4J523	O 形圈	2	
33	9S8005	螺塞	1	
34	3K0360	O 形圈	1	
35	6J1038	O 形圈	3	
36	1B8707	半圆键	1	
37	3J7582	摇臂	1	
38	4B3388	螺栓	4	
39	9M1974	垫圈	4	
40	7J2596	盖	1	
41	3J5552	密封垫	1	
42	2A4996	螺栓	1	
43	9J0791	壳体	1	
44	5K3607	管接头	1	
45	5F1678	O 形圈	3	
46	9T1191	阀体	1	
47	1P4578	分离式法兰	6	
48	3H5368	螺栓	12	
49	9J1999	阀座	2	

1U1819—XG 推土铲控制阀 (外配套件)
BULLDOZER CONTROL VALVE (PURCHASED PARTS)

序号 NO.	代 号 PART NO.	名 称 NAME	数量 Q'TY	备注 REMARK
50	5J1389	弹簧	2	
51	0S1571	螺栓	4	
52	GB308—77	钢球 9/32"	2	
53	5H6005	O 形圈	2	
54	2A4639	螺栓	9	
55	0S1594	螺栓	3	
56	9T3746	阀芯	1	
57	8J7360	螺塞	1	
58	1L4418	弹簧	1	
59	2S4078	O 形圈	1	
60	4J0523	O 形圈	1	
61	3G1201	阀	1	
62	1D4566	螺栓	4	
63	9J5498	弹簧	1	
64	7D9749	O 形圈	1	
65	9J5499	弹簧	1	
66	8J7462	座盖	1	
67	8J7317—XG	阀体	1	
68	9T3748	阀芯	2	
69	3G3475	弹簧	2	
70	4J8997	O 形圈	2	
71	3G8710	螺塞	2	
72	9J1302	轴	1	
73	6V4253	油封	1	

1U1819—XG 推土铲控制阀 (外配套件)

BULLDOZER CONTROL VALVE (PURCHASED PARTS)

序号 NO.	代 号 PART NO.	名 称 NAME	数量 Q' TY	备注 REMARK
74	2K5830	滚针轴承 NEEDLE BEARING	1	
76	5J3241	滚针轴承 NEEDLE BEARING	1	
77	D813128—XG	护套 GUARD SLEEVE	2	
78	D813129—XG	调节杆 LEVER ADJVSTMENT	2	
79	336039	O 形圈 O—RING	2	
80	GB91—86	开口弹簧销 COTTER SPRING PIN 2×15	2	
81	D813130—XG	背母 NUT	2	
82	D813131—XG	调整垫 SHIM	2	
83	D813132—XG	杆座 LEVER SEAT	2	
84	2J6089	先导弹簧 SPRING	2	
85	6J1311	杆 LEVER	2	
86	1J8497	阀 VALVE	2	
87	8J7462	座盖 COVER	1	
88	3S9233	O 形圈 O—RING	1	
89	4J8997	O 形圈 O—RING	2	
90	5J4664	弹簧 SPRING	1	
91	9J4794	阀柱 VALVE SPOOL	1	
92	1P4577	分离式法兰 FLANGE	6	
93	0S1588	螺栓 BOLT	12	
94	5M2894	垫圈 WASHER	12	
95	3G8415	盖 COVER	2	
96	9J5754	弹簧 SPRING	2	
97	9J5753	弹簧 SPRING	2	
98	2G1258	定位套 DETENT SLEEVE	2	

1U1819—XG 推土铲控制阀 (外配套件)
BULLDOZER CONTROL VALVE (PURCHASED PARTS)

序号 NO.	代 号 PART NO.	名 称 NAME	数量 Q'TY	备注 REMARK
99	4J0522	O 形圈	4	
100	4J8996	O 形圈	2	
101	8J7366	螺塞	2	
102	2N7029	弹簧	2	
103	9T3741	阀芯	2	
104	1U368	阀芯	1	
105	9T5768	卸荷阀体	1	
106	300167	环	2	
107	8J2415	垫圈	2	
108	D13118—XG	摇臂	1	

1T13300 油 箱 OIL TANK

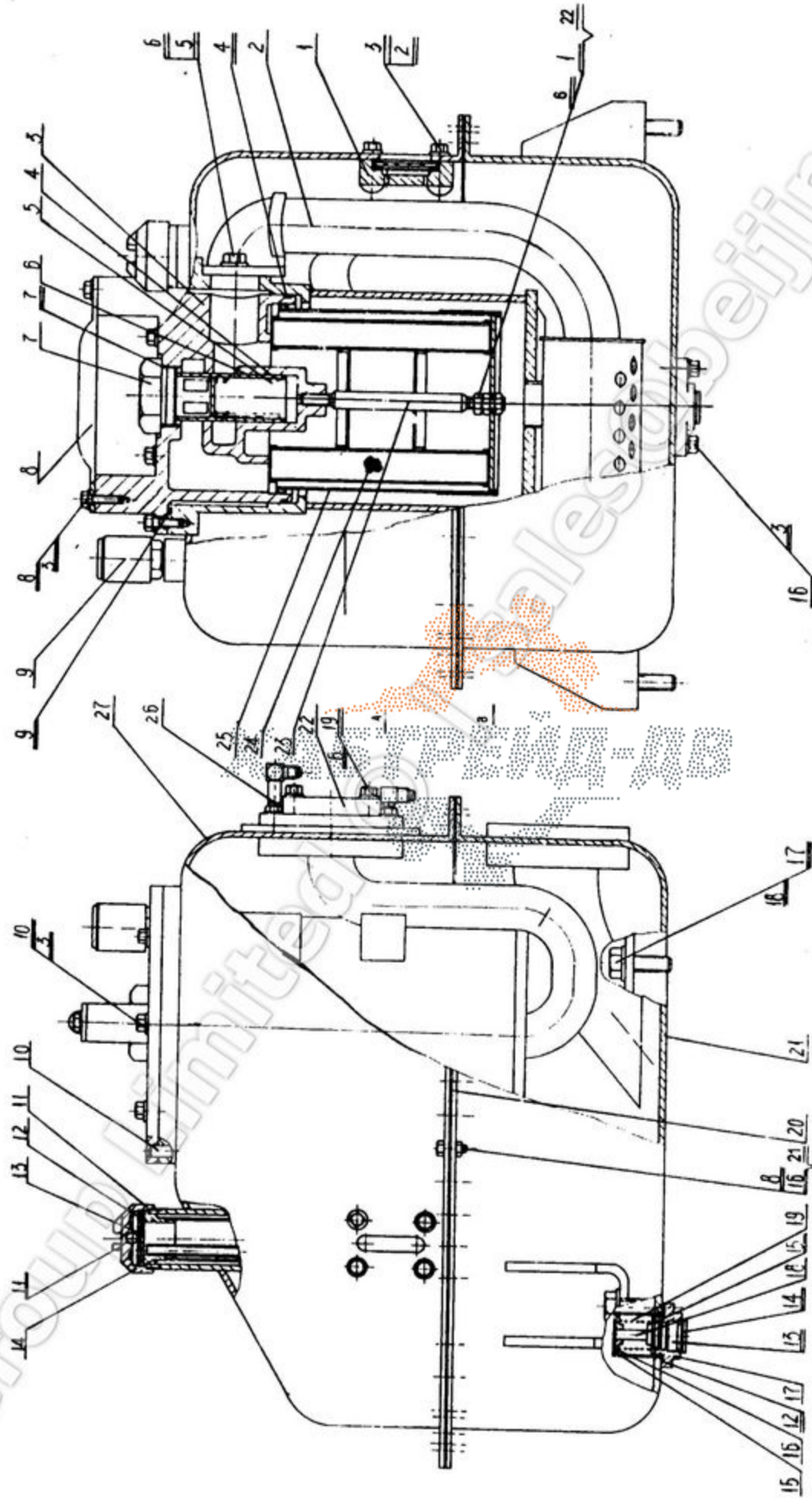

1T13300 油 箱 OIL TANK

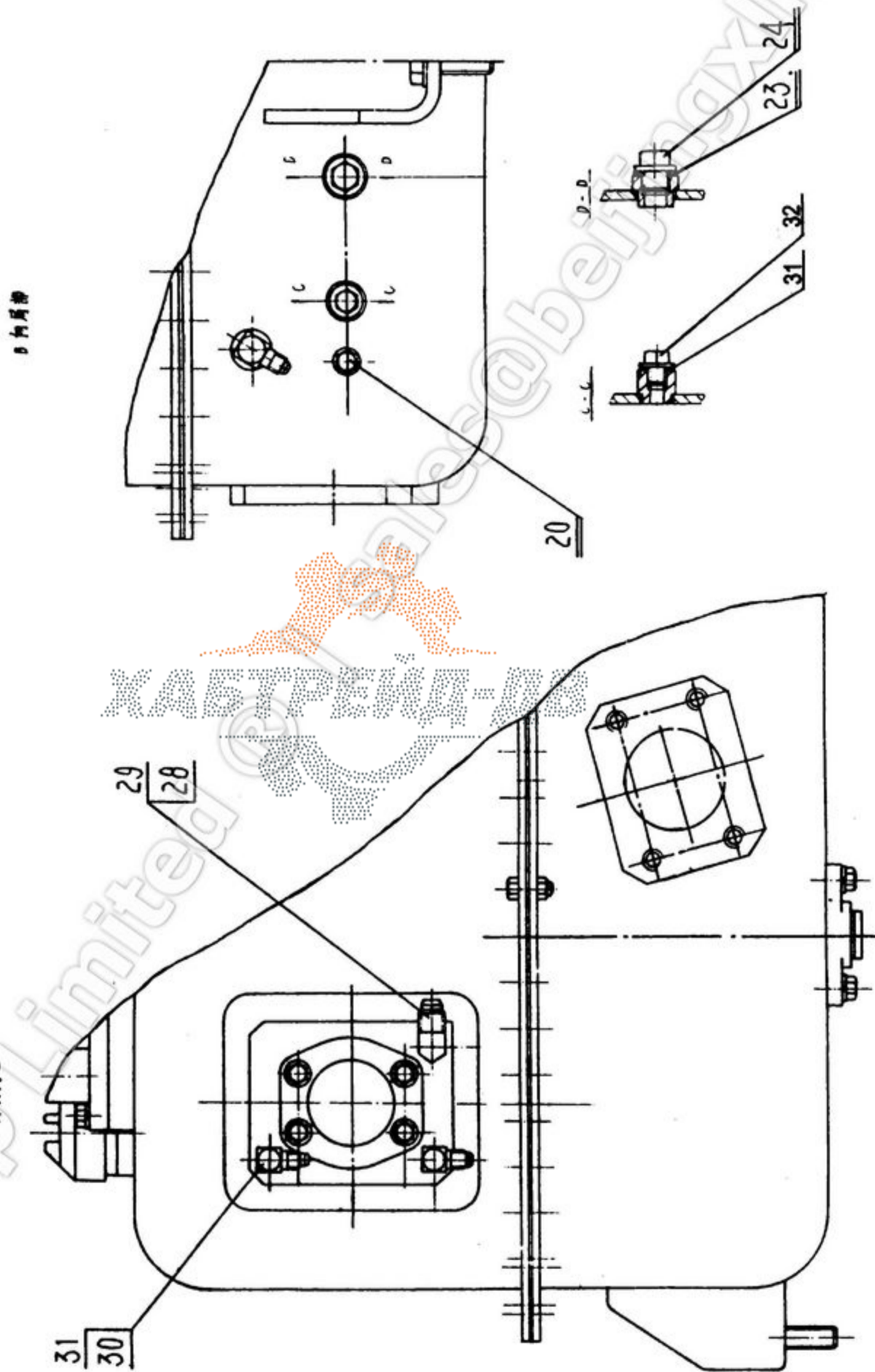

1T13300 油 箱 OIL TANK

序号 NO.	代 号 PART NO.	名 称 NAME	数量 Q' TY	备注 REMARK
1	1T13301	油标组件	1	
2	1T13303	网筒组件	1	
3	1T13309	分油座	1	
4	1T13310	外弹簧	1	
5	1T13311	内弹簧	1	
6	1T13312	阀芯	1	
7	1T13313	塞堵	1	
8	1T13314	扶手	1	
9	0T13165	进排气阀组件	1	
10	1T13315	圆柱销	1	
11	0A34006	螺盖	1	
12	0A34008	橡胶板	1	
13	0A34007	板	1	
14	1B09240	滤网组件	1	
15	0T13197	内筒	1	
16	0T13198	弹簧座	1	
17	0T13201	外座	1	
18	0T13200	阀芯	1	
19	0T13199	弹簧	1	
20	1T13316	密封垫	1	
21	1T13317	下箱体组件	1	
22	1T13347	压盖	2	
23	1T13328	双头螺栓	1	
24	1T13329	滤芯	1	
25	1T13330	粗滤筒组件	1	
26	1T13034	长直角弯头组件	1	
27	1T13334	上箱体组件	1	
28	1B01328	O 形圈	1	
29	1B38085	直角管接头	1	
30	1B01524	弯头	2	
31	1B01382	O 形圈	3	
32	1B09153	塞堵	1	

1T13300 油 箱 OIL TANK

序号 NO.	代 号 PART NO	名 称 NAME	数量 Q' TY	备注 REMARK
1	GB6170—86	螺母 M12	3	
2	GB5783—86	螺栓 M10×20	4	
3	GB95—85	垫圈 10	14	
4	GB3452.1-82	O 形圈 206×7	1	
5	GB5783—86	螺栓 M12×30	2	
6	GB95—85	垫圈 12	7	
7	GB3452.1-82	O 形圈 58×3.55	1	
8	GB5783—86	螺栓 M10×30	64	
9	GB3452.1-82	O 形圈 236×5.3	1	
10	GB5783—86	螺栓 M10×30	6	
11	GB308—77	钢球 Ø10.5	1	
12	GB3452.1-82	O 形圈 51.5×3.55	1	
13	JB1001—77	螺塞 M33×2	1	
14	JB982—77	垫圈 33	1	
15	GB3452.1-82	O 形圈 26.5×3.55	1	
16	GB6170—86	螺母 M10	64	
17	GB5783—86	螺栓 M16×35	3	
18	GB98—85	垫圈 16	3	
19	GB5783—86	螺栓 M12×40	4	
20	GB5783—86	螺栓 M10×15	1	
21	JB982—77	垫圈 10	64	
22	JB1000—77	垫圈 12	1	
23	JB982—77	垫圈 20	1	
24	JB1000—77	螺塞 M20×1.5	1	

1T14000 推土装置 IMPLEMENT

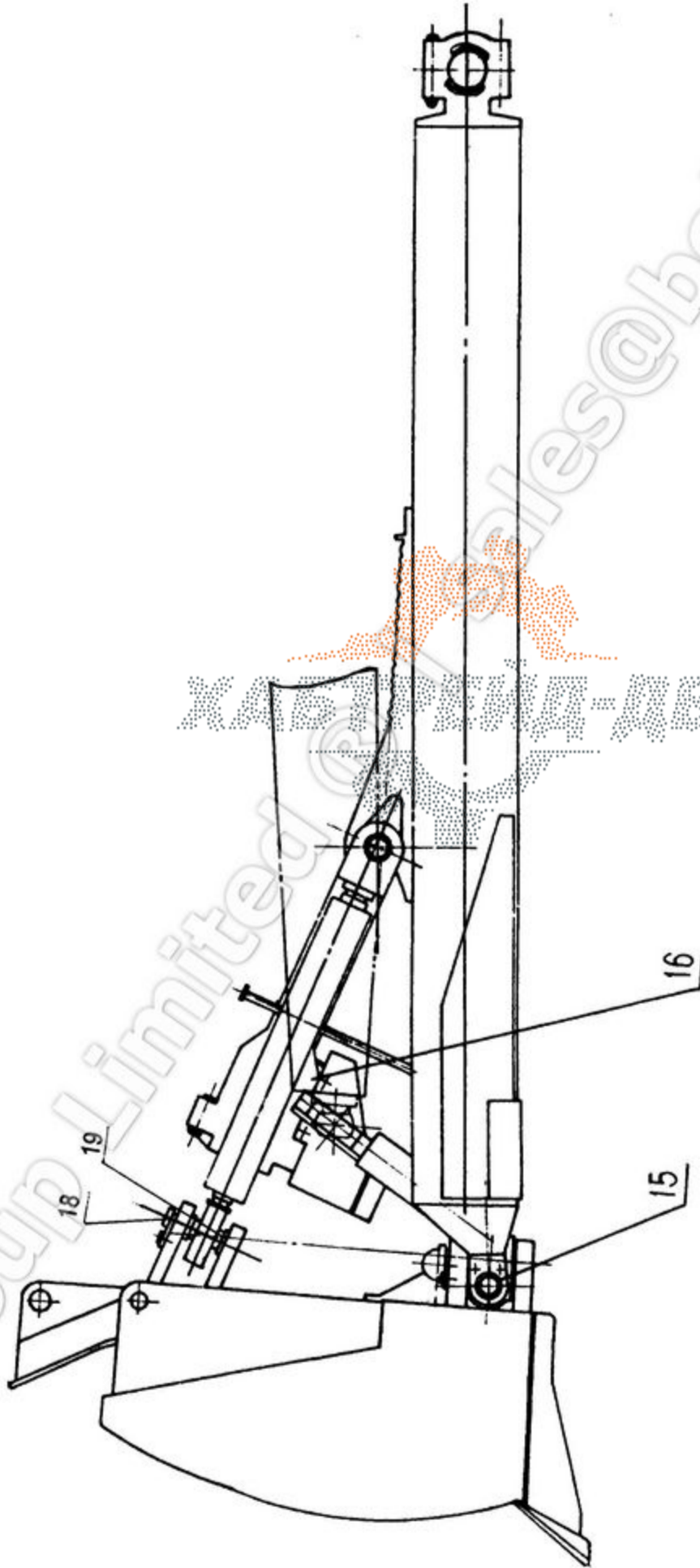

0T14000 推土装置 IMPLEMENT

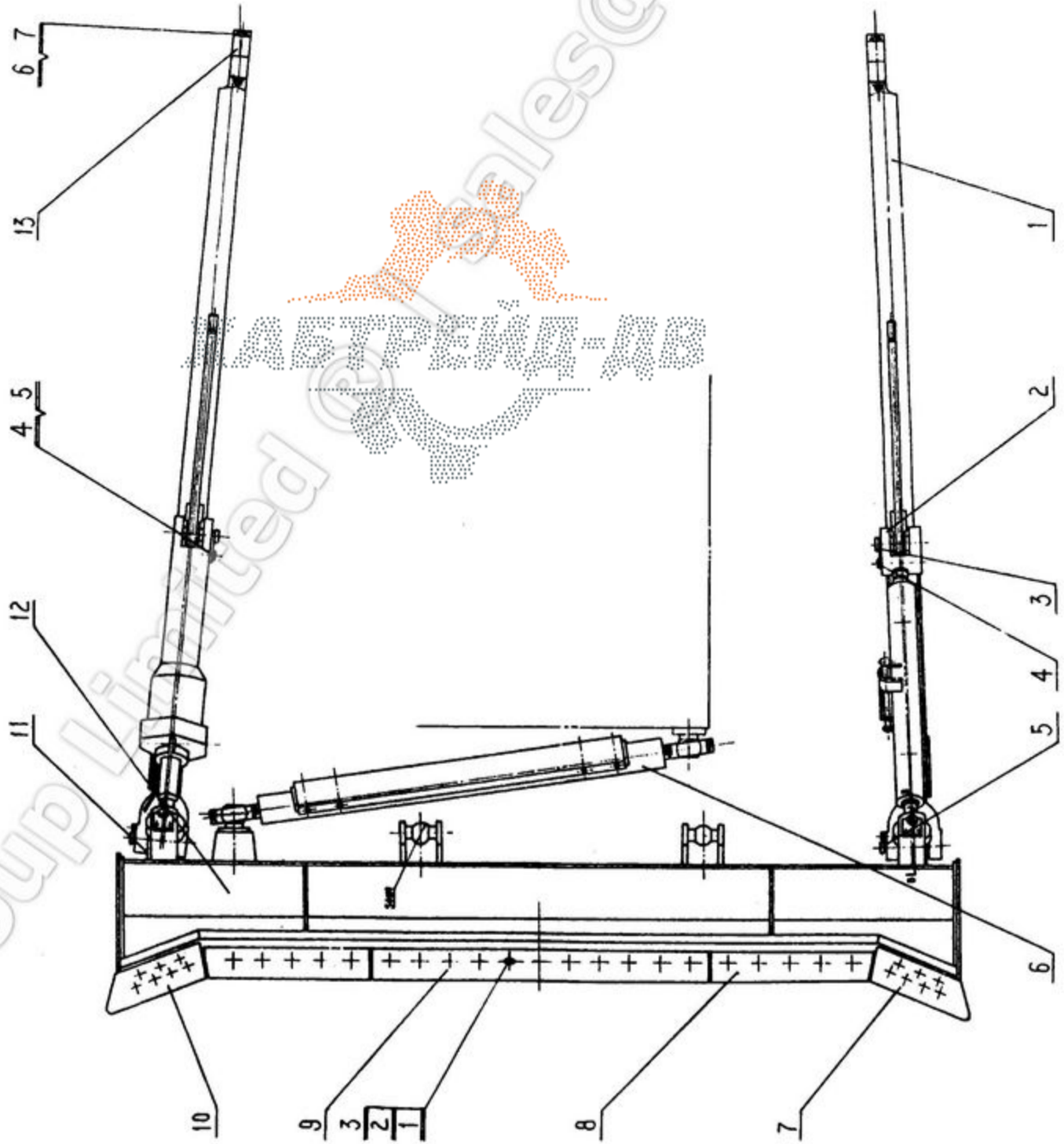
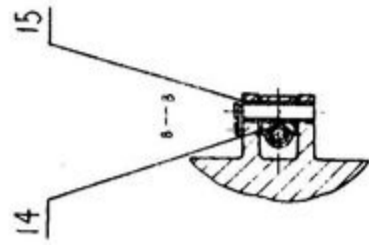

14-2

1T14000 推土装置 IMPLEMENT

序号 NO.	代 号 PART NO.	名 称 NAME	数量 Q' TY	备注 REMARK
1	1T14001	左顶推梁	BRACE LEFT	1
2	1T14011	支臂	ARM	1
3	1T14022	销轴 I	PIN I	2
4	1T14023	挡板	BAFFLE	6
5	1T14024	销轴 II	PIN II	4
6	1T14025	斜支撑	LEAN BRACE	1
7	1T14033	左刀角	BIT (L. H)	1
8	1T14034	左右刀片	EDGE, LEFT	2
9	1T14035	中间刀片	MIDDLE EDGE	1
10	1T14036	右刀角	BIT (R. H)	1
11	1T14037	右顶推梁	BRACE, RIGHT	1
12	1T14040	铲刀	BLADE	1
13	1T14072	支承球盖	COVER	2
14	1T14073	十字叉头	YOKE	2
15	1T14074	套	SLEEVE	16
16	1T14100	侧倾油缸	TILT CYLINDER	1
18	1T14078	销轴 III	PIN III	2
19	1T14080	隔垫	SPACER	4
1	JB/T2648. 3-95	螺栓 M24×90	BOLT M24×90	35
2	GB/T1229-91	螺母 M24	NUT M24	35
3	GB/T1230—91	垫圈 24	WASHER M24	35
4	GB5783—86	螺栓 M20×50	BOLT M20×50	12
5	GB95—85	垫圈 20	WASHER 20	12
6	GB5782—86	螺栓 M36×240	BOLT M36×240	4
7	GB6170—86	螺母 M36	NUT M36	4

1T14011 支 臂 ARM

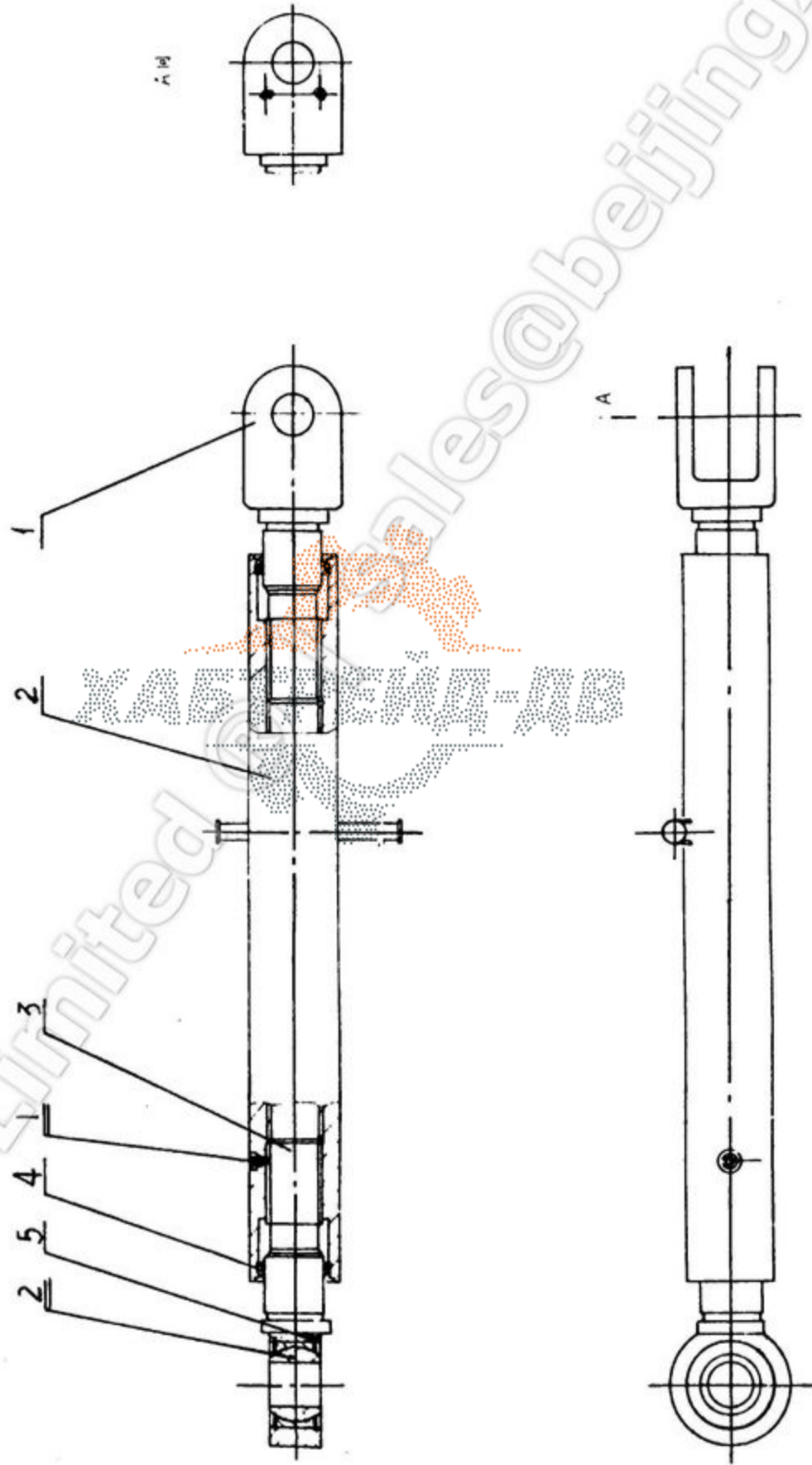

1T14011 支 臂

序号 NO.	代 号 PART NO.	名 称 NAME	数量 Q' TY	备注 REMARK
1	1T14012	螺纹调节叉臂 YOKE ARM	1	
2	1T14013	支臂焊接件 ARM WELD	1	
3	1T14019	螺纹拉杆 ROD	1	
4	1T14020	防尘圈 DUST PROOF RING	2	
5	1T14021	卡环 CLIP RING	2	
1	GB1152—89	油杯 M10×1 OIL CUP M10×1	3	
2	304.5—81	关节轴承 GEG70ES BEARING, SPHERICAL PLAIN GEG70ES	1	

1T14025 斜支撑 LEAN BRACE

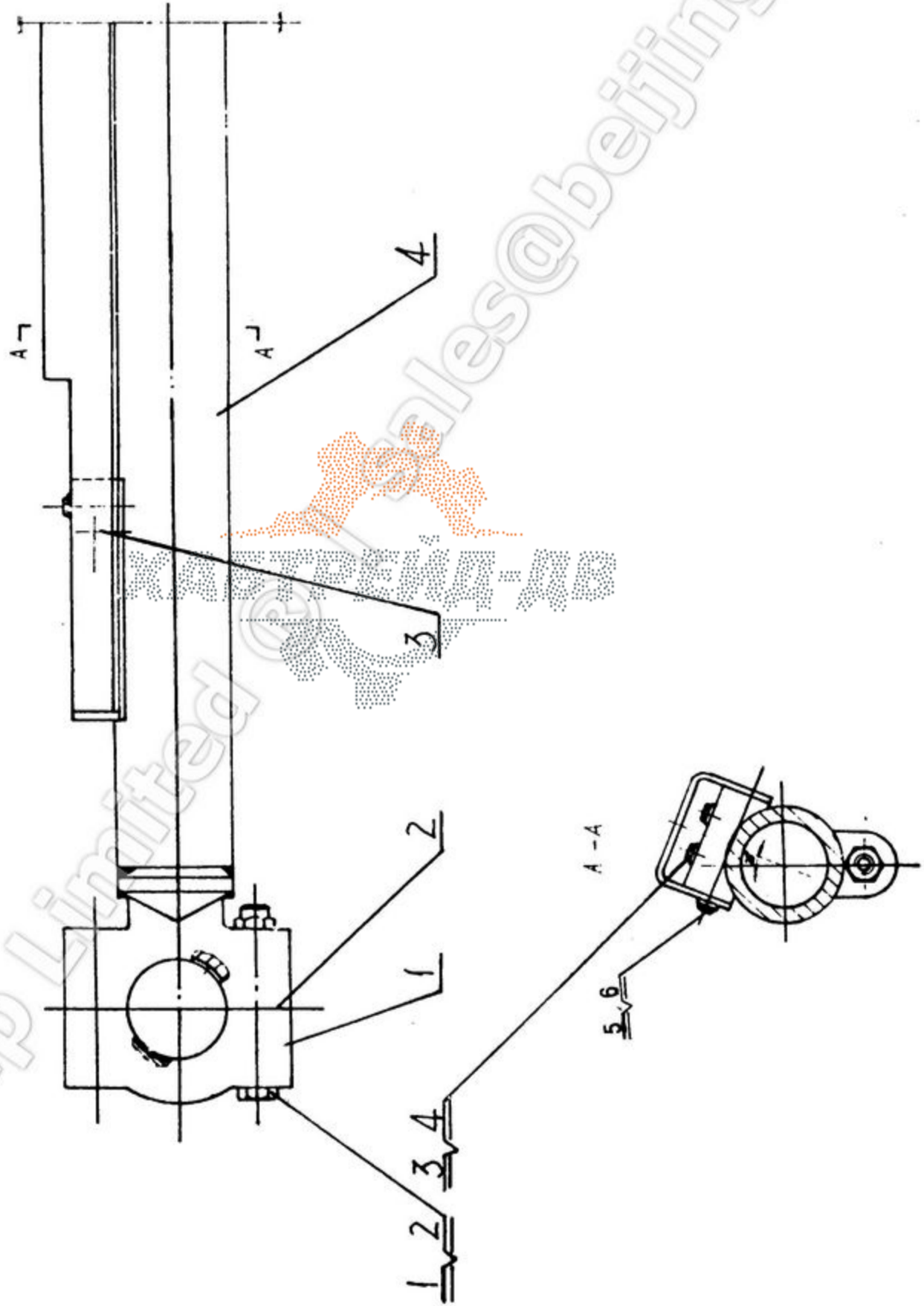

1T14025 斜支撑 LEAN BRCE

序号 NO.	代 号 PART NO.	名 称 NAME	数量 Q' TY	备注 REMARK
1	1T14026	球盖	2	
2	1T14027	调整垫片	24	
3	1T14028	护罩	1	
4	1T14029	支撑焊接件	1	
1	GB5782—86	螺栓 M36×220	4	
2	GB6170—86	螺母 M36	4	
3	GB5783—86	螺栓 M16×50	4	
4	GB95—85	垫圈 16	4	
5	GB5783—86	螺栓 M12×30	4	
6	GB95—85	垫圈 12	4	

1T14100 侧倾缸总成 TILT CYLINDER ASSEM

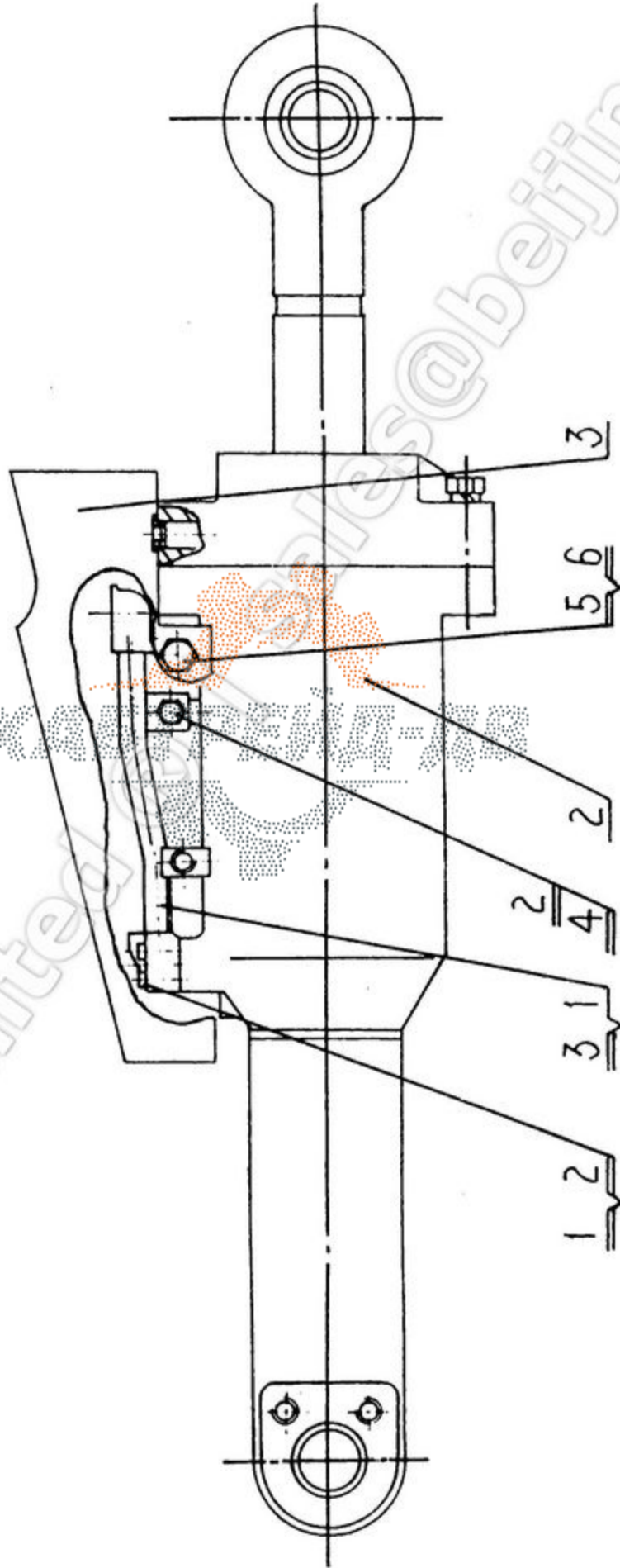

1T14100 侧倾缸总成 TILT CYLINDER ASSEM

序号 NO.	代 号 PART NO.	名 称 NAME	数量 Q' TY	备注 REMARK
1	1T14102	侧倾硬管 PIPE	1	
2	1T14107	侧倾油缸 CYLINDER	1	
3	1T14101	护罩 GUARD HOUSING	1	
1	GB5782—86	螺栓 M10×50 BOLT M10×50	4	
2	GB93—87	垫圈 10 WASHER 10	5	
3	GB3452. 1-82	O 形圈 O—RING 25×3. 55 25×3. 55	1	
4	GB5782—86	螺栓 M10×40 BOLT M10×40	1	
5	GB93—87	垫圈 20 WASHER 20	4	
6	GB5783—86	螺栓 M20×35 BOLT M2×35	4	

1T14107 侧倾油缸 TILT CYLINDER

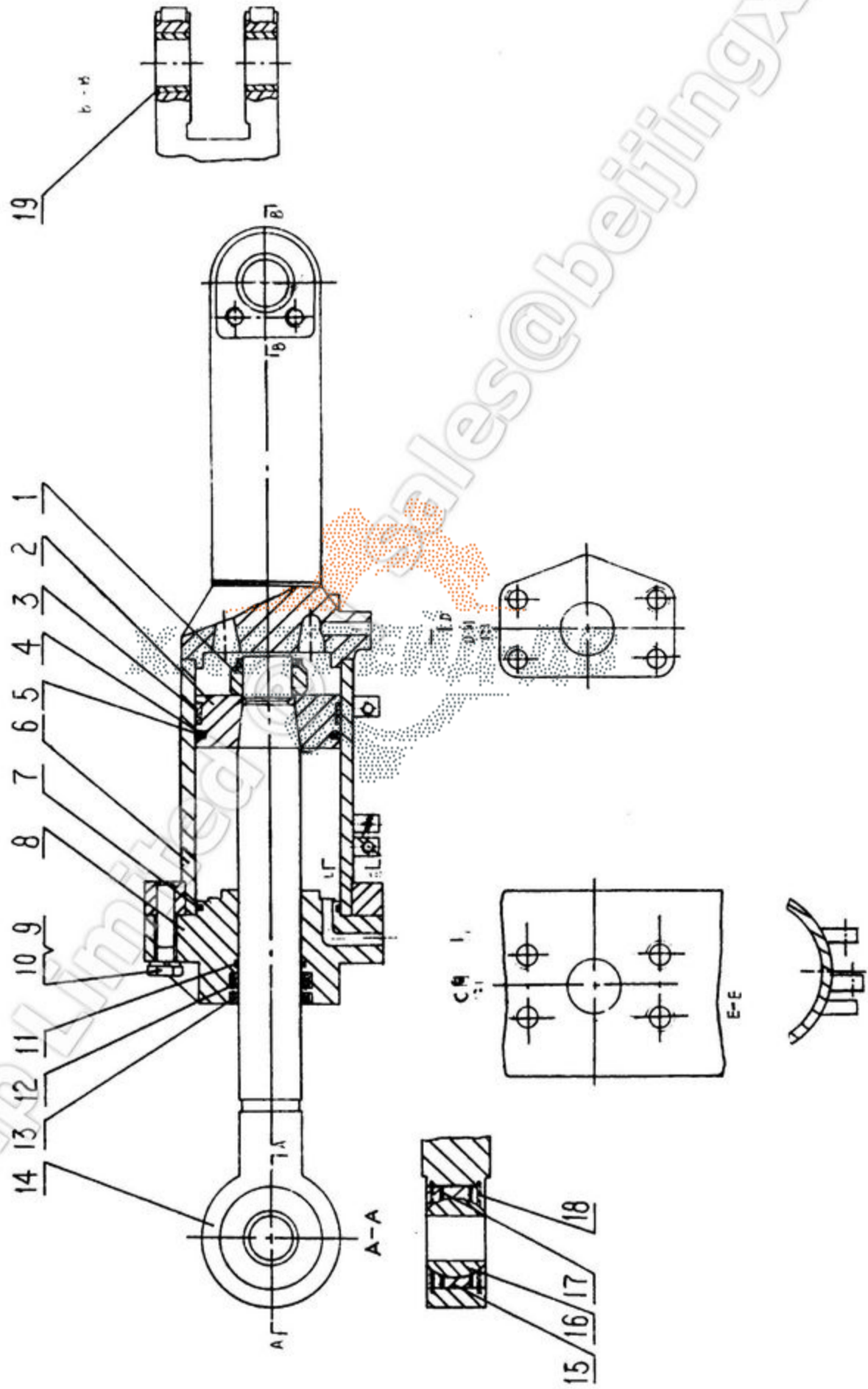

1T14107 侧倾油缸 TILT CYLINDER

序号 NO.	代 号 PART NO.	名 称 NAME	数量 Q' TY	备注 REMARK
1	1T14108	防松螺母	1	
2	1T14109	活塞	1	
3	1T14110	衬环	1	
4	1T14111	橡胶环	1	
5	1T14112	密封圈	1	
6	1T14113	缸筒焊接体	1	
7	1T14115	密封组件	1	
8	1T14116	缸头	1	
9	1T117	螺栓	6	
10	1T14118	垫圈	6	
11	1T14119	矩形密封圈	1	
12	1T14120	密封圈	1	
13	1T14121	防尘圈	1	
14	1T14122	活塞杆	1	
15	1T14123	球瓦	2	
16	1T14124	球套	2	
17	1T14125	弹簧	2	
18	1T14126	卡环	2	
19	1T14127	衬套	2	

HSGF—200×178/80E 侧倾油缸 (外配套件)
TILT CYLINDER (PURCHASED PARTS)

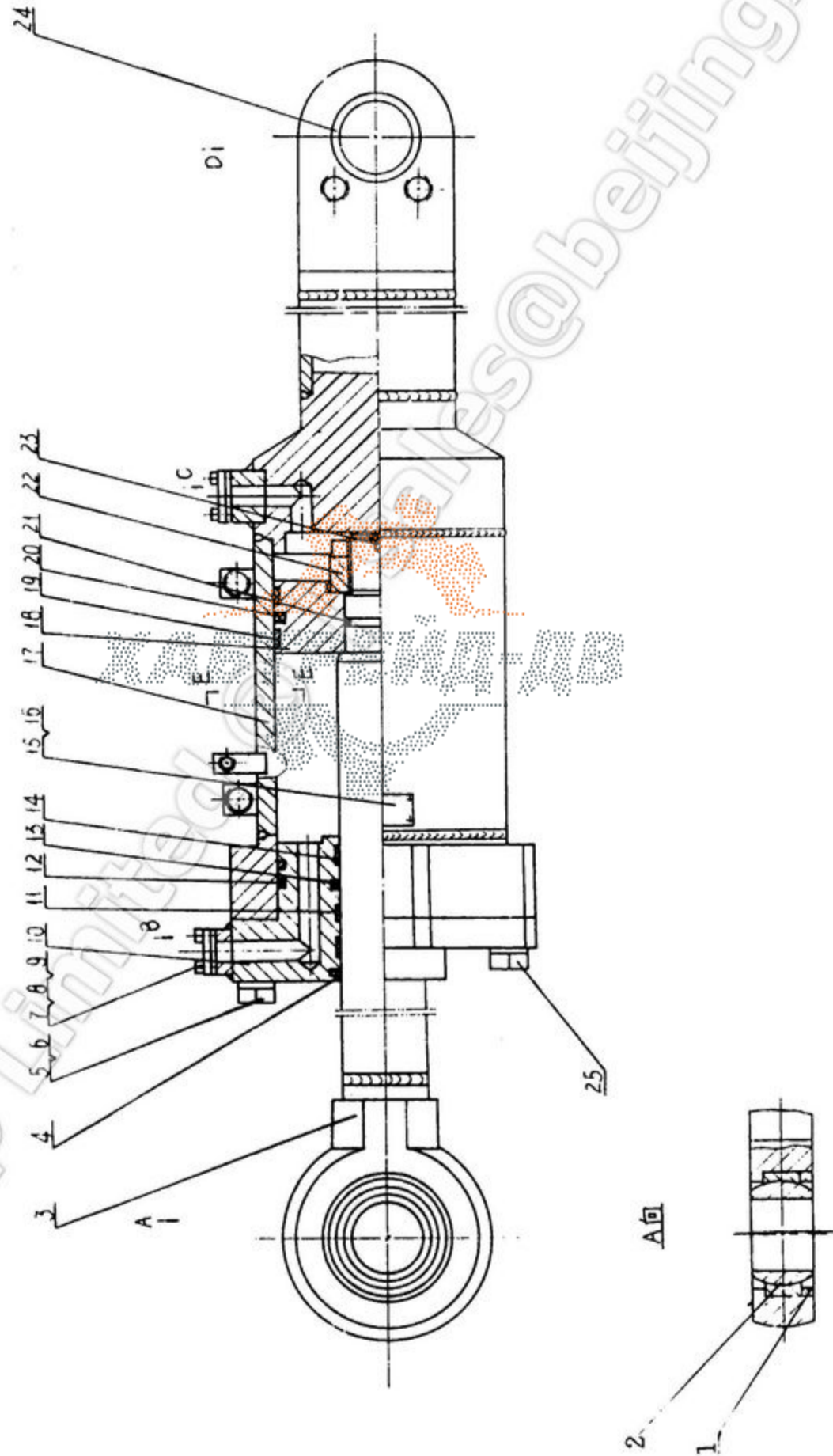

HSGF—200×178/80E 侧倾油缸 (外配套件)

TILT CYLINDER (PURCHASED PARTS)

序号 NO.	代 号 PART NO.	名 称 NAME	数量 Q' TY	备注 REMARK
1	XH08—1	挡套	1	
2	GB304.9—81	关节轴承	1	
3	XH0801	活塞杆组件	1	
4	CK80	防尘圈 K80	1	
5	GB5782—86	螺栓 M24×130	2	
6	GB97.1—85	垫圈 24 200HV	8	
7	GB5783—86	六角螺栓 M10×20	4	
8	XH08—2	垫板	2	
9	XH01—6	护垫	2	
10	XH0803	导向套组件	1	
11	Yxd (80 × 92 × 14)	Yx 型轴用密封圈	1	
12	GB3452.1-82	O 型圈 70018500	2	
13	CKS—0800	斯特封	1	
14	ZL5001—7	导向环	2	
15	XH08—3	铭牌	1	
16	GB827—86	铆钉 3×3	4	
17	XH0802	缸体组件	1	
18	XH08—17	活塞	1	
19	ZL50E02—8	导向环	2	
20	CKW2000	CKW 孔用组合密封	1	
21	GB3452.1-82	O 型圈 35505800	1	
22	XH05—2	螺母	1	
23	GB91—86	开口销 Ø5×70	1	
24	XH08—4	轴套	2	
25	GB5783—86	螺栓 M24×90	6	

1T15000 仪表盘司机座总成
DASH—OPERATOR SEAT GROUP

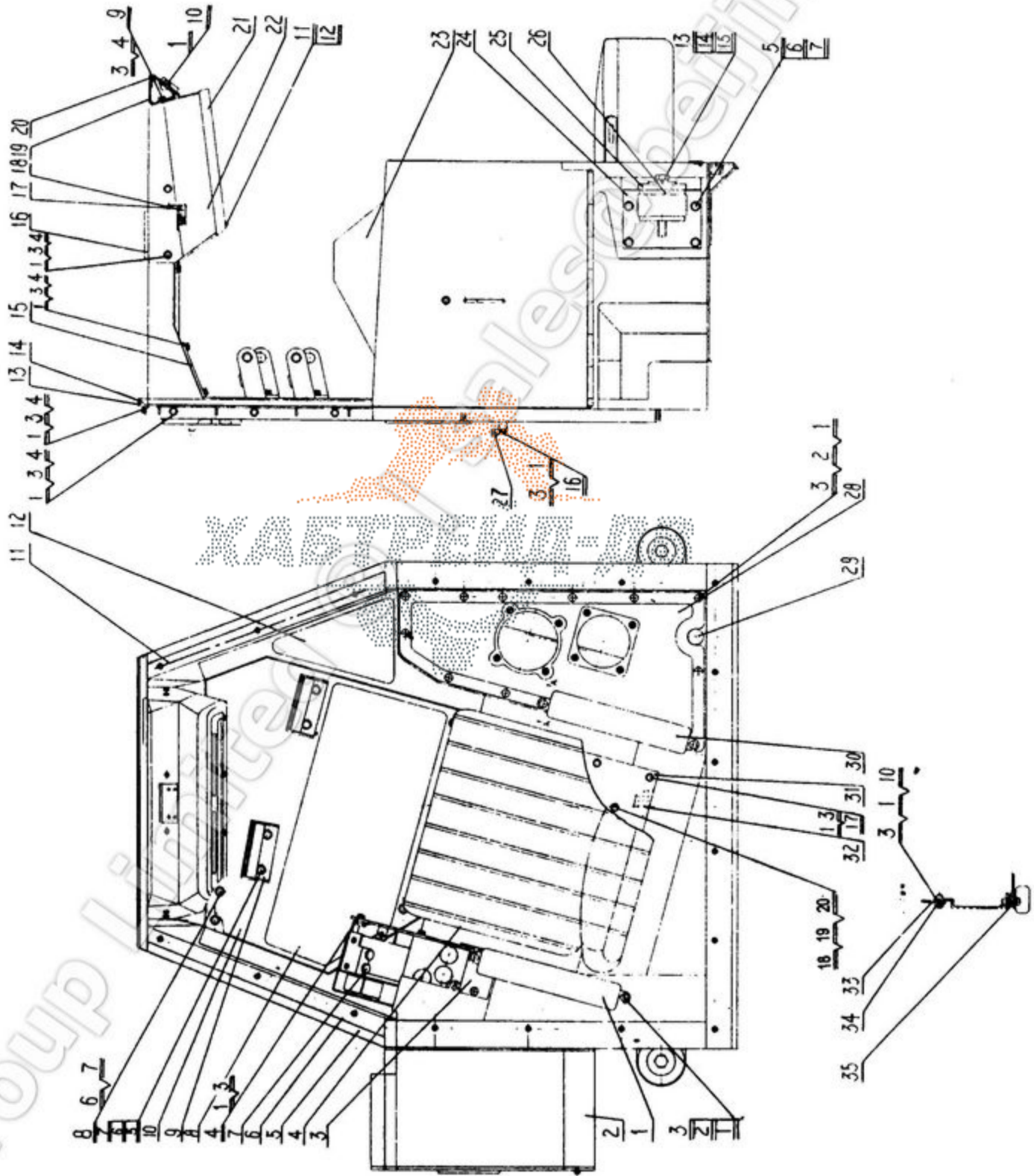

1T15000 仪表盘司机座总成
DASH—OPERATOR SEAT GROUP

序号 NO.	代 号 PART NO.	名 称 NAME	数量 Q' TY	备注 REMARK
1	0T15181	左扶手	1	
2	1T15156	空调器箱体	1	
3	1T15038	左内侧板	1	
4	1T15200	推土机座椅	1	
5	1T15001	密封条	2	
6	1T15042	地板左边板组件	1	
7	1T15018	橡胶块	2	
8	1T15002	踏板	1	
9	0T15137	脚支架	2	
10	1T15049	地板	1	
11	1T15056	地板右边板组件	1	
12	1T15003	踏板	1	
13	1T15004	前护框	1	
14	1T15005	密封条	1	
15	1T15006	转向机构固定板	1	
16	1T15007	盖	1	
17	1T15008	护线套压盖	1	
18	1T15009	护线套	1	
19	1T15058	连接座组件	1	
20	1T15061	面板组件	1	
21	1T15010	仪表盘面	1	
22	1T15064	仪表盘架	1	
23	1T15073	仪表盘司机座焊接 体	1	
24	1T15019	后连接座	2	
25	1T15011	盖	2	
26	1T15022	缓冲垫	4	

1T15000 仪表盘司机座总成
DASH—OPERATOR SEAT GROUP

序号 NO.	代 号 PART NO.	名 称 NAME	数量 Q'TY	备注 REMARK
27	1T15012	线夹	1	
28	1T15025	右上面板	1	
29	1T15013	堵	1	
30	0T15186	右扶手	1	
31	1T15031	座椅底板	1	
32	1T15014	密封条	1	
33	1T15015	盖板	1	
34	1T15016	密封垫	1	
35	1T15017	垫板	1	
1	GB97.1—85	垫圈 10	57	
2	GB818—85	螺钉 M10×30	14	
3	GB93—87	垫圈 10	57	
4	GB5783—86	螺栓 M10×25	24	
5	GB5780—86	螺栓 M12×45	12	
6	GB93—87	垫圈 12	12	
7	GB95—85	垫圈 12	12	
8	GB5780—86	螺栓 M12×55	4	
9	GB96—85	垫圈 10	2	
10	GB818—85	螺钉 M10×25	10	
11	GB818—85	螺钉 M6×20	8	
12	GB97.1—85	垫圈 6	8	
13	GB5780—86	螺栓 M20×120	2	
14	GB93—87	垫圈 20	2	
15	GB5287—85	垫圈 20	2	
16	GB5783—86	螺栓 M10×15	1	
17	GB5783—86	螺栓 M10×35	10	
18	GB5783—86	螺栓 M8×25	4	
19	GB97.1—85	垫圈 8	4	
20	GB41—86	螺母 M8	4	

1T16000 左行走系统 LEFT UNDERCARRIAGE SYSTEM

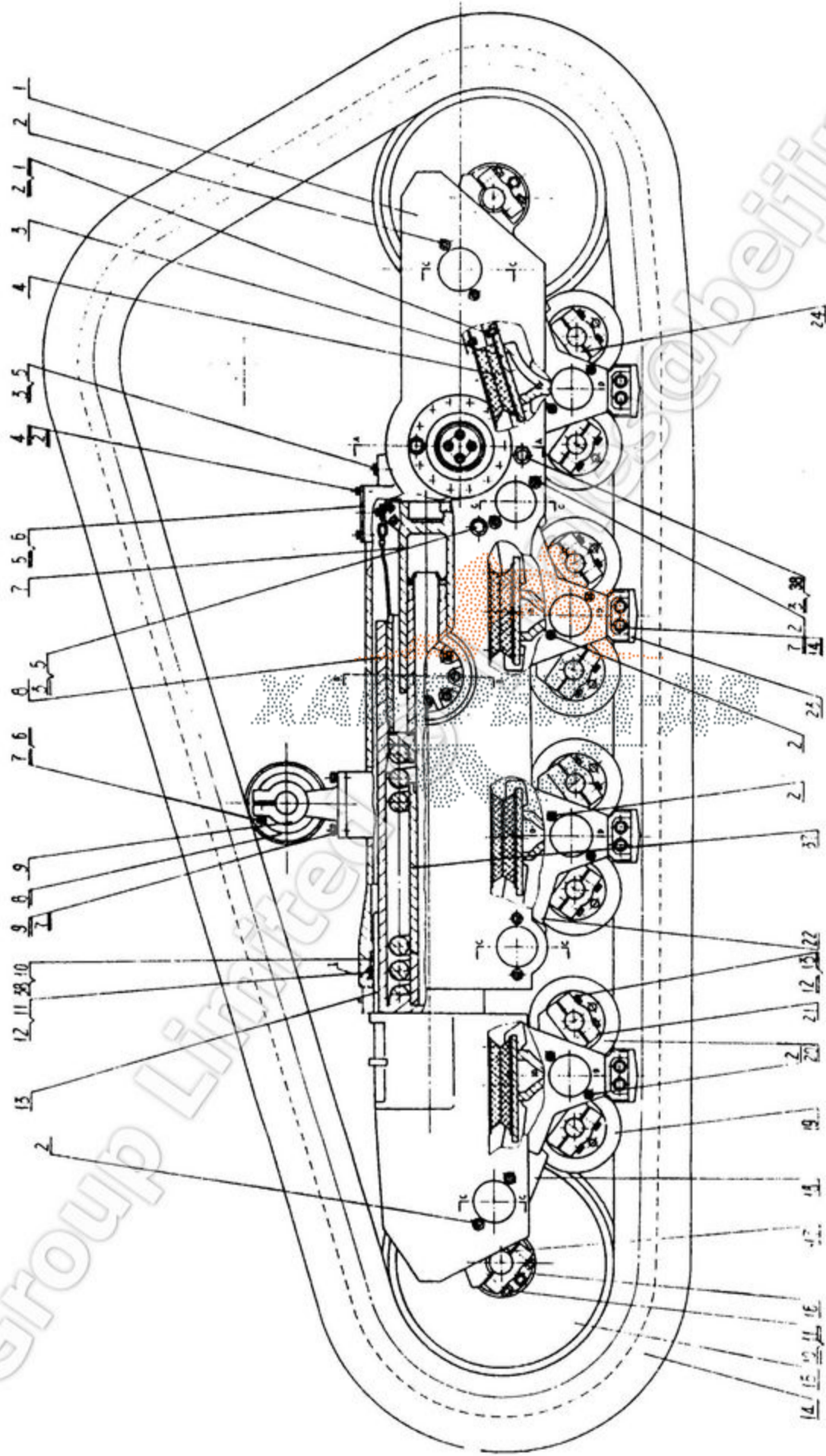

1T16000 左行走系统 LEFT UNDERCARRIAGE SYSTEM

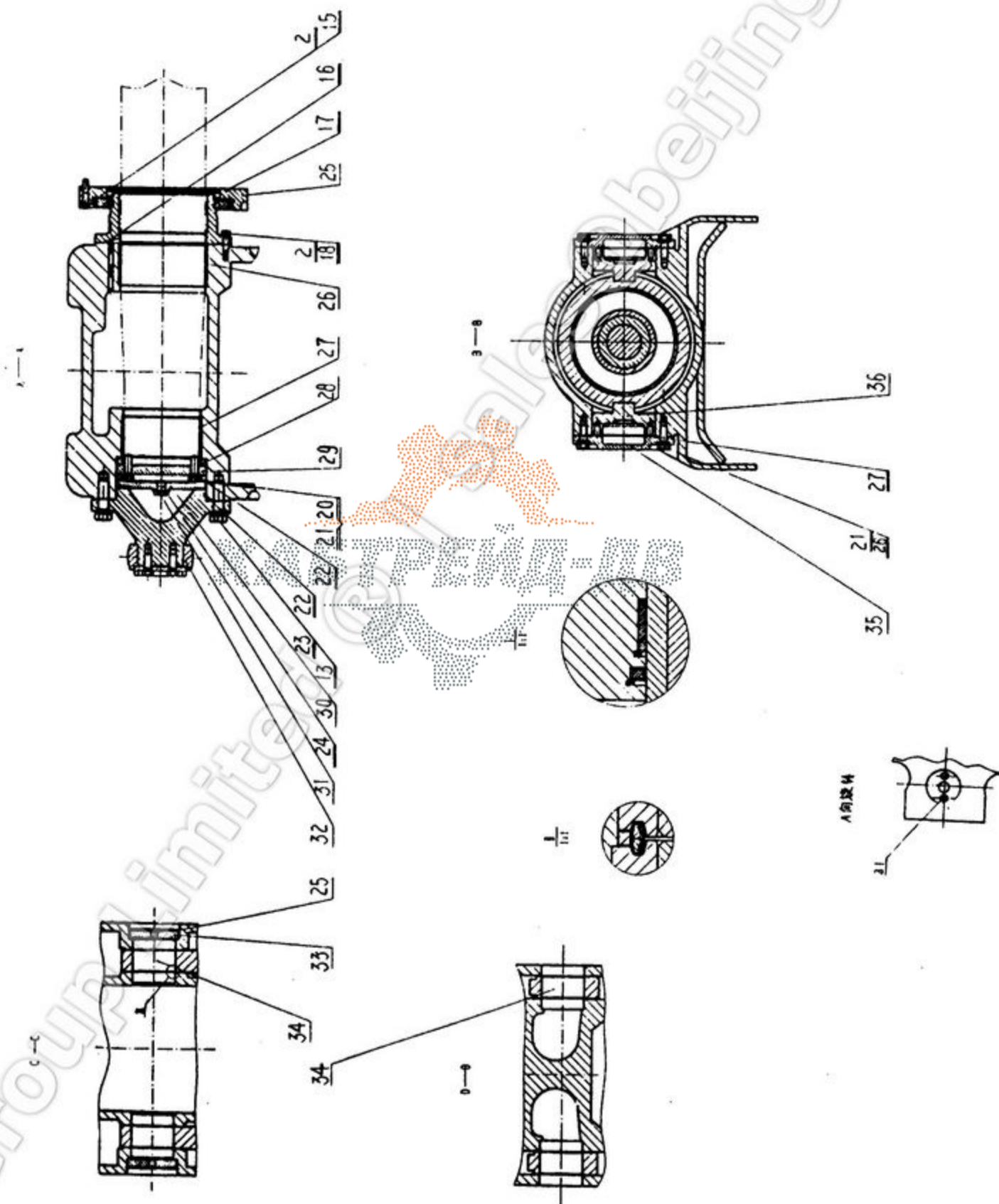

1T16000 左行走系统 LEFT UNDERCARRIAGE SYSTEM

序号 NO.	代 号 PART NO.	名 称 NAME	数量 Q' TY	备注 REMARK
1	1T16001	左行走架焊接	1	
2	1T17163	螺堵	32	
3	1T17036	后摆架	1	
4	1T17127	橡胶减振组件	8	
5	1T17162	油塞	2	
6	1T17124	盖组件	1	
7	1T16004	左履带涨紧装置	1	
8	1T17001	叉头	1	
9	1T17130	托轮座	1	
10	1T17180	大衬套	1	
11	1T17181	密封组件	1	
12	1T17179	外挡环	1	
13	1T17073	导向套	1	
14	1T17165	履带总成 228.6—560—43	1	
15	1T17096	引导轮	2	
16	1T17038	引导轮压盖组件	4	
17	1T17041	半衬套	4	
18	1T17026	前摆架	1	
19	1T17084	单边支重轮总成	4	
20	1T17092	双边支重轮总成	4	
21	1T17035	支重轮压盖组件	16	
22	1T17032	中摆架	2	

1T16000 左行走系统 LEFT UNDERCARRIAGE SYSTEM

序号 NO.	代 号 PART NO.	名 称 NAME	数量 Q'TY	备注 REMARK
23	1T17164	护块	8	
24	1T17034	小摆架	8	
25	1T17064	连接盘组件	1	
26	1T17160	大衬套	1	
27	1T17161	小衬套	1	
28	1T17114	隔环	1	
29	1T17115	压盘	1	
30	1T17116	盖	1	
31	1T17117	螺塞	1	
32	1T17118	球座组件	1	
33	1T17113	堵盖	8	
34	1T17074	润滑销轴	16	
35	1T17122	盖	2	
36	1T17123	定位键	2	
37	1T17178	内挡环	1	
38	1T17201	油塞	1	
1	GB5783—86	螺栓 M12×25	32	
2	GB93—87	垫圈 12	52	
3	GB3452.1-82	O 形圈 33.5×3.55	3	
4	GB5783—86	螺栓 M12×30	4	
5	GB3452.1-82	O 形圈 145×5.3	1	
6	GB5782—86	螺栓 M20×80	2	
7	GB93—87	垫圈 20	21	

1T16000 左行走系统 LEFT UNDERCARRIAGE SYSTEM

序号 NO.	代 号 PART NO.	名 称 NAME	数量 Q' TY	备注 REMARK
8	JB2984—81	托链轮 228.5×200	1	
9	GB5783—86	螺栓 M20×50	4	
10	GB5782—86	螺栓 M30×120—10.9	32	
11	GB93—87	垫圈 30	9	
12	GB5782—86	螺栓 M24×90—10.9	8	
13	GB93—87	垫圈 24	46	
14	GB5783—86	螺栓 M20×55	16	
15	GB5782—86	螺栓 M12×60	8	
16	GB3452.1-82	O 形圈 250×5.3	1	
17	GB3452.1-82	O 形圈 300×5.3	1	
18	GB5783—86	螺栓 M12×40	8	
20	GB5783—86	螺栓 M16×50	12	
21	GB93—87	垫圈 16	24	
22	GB3452.1-82	O 形圈 200×5.3	2	
23	GB5783—86	螺栓 M24×80—10.9	14	
24	GB3452.1-82	O 形圈 20×3.55	1	
25	GB893.2—86	挡圈 120	8	
26	GB5783—86	螺栓 M16×45	12	
27	GB3452.1-82	O 形圈 155×3.55	2	

1T16004 左履带张紧装置
 TRACK RECOIL SPRING CYLINDER ADJUSTER, LEFT

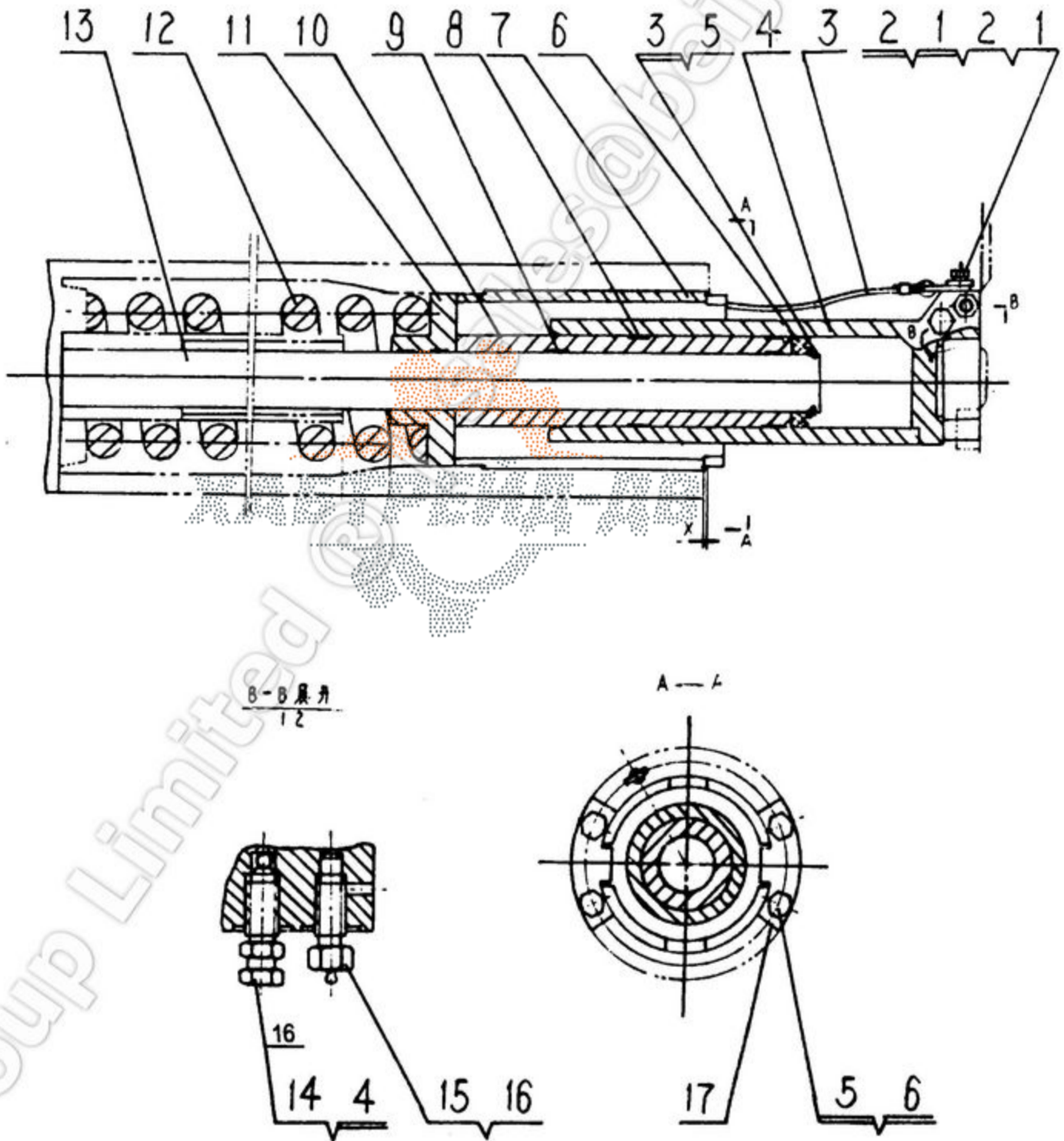

1T16004 左履带张紧装置

TRACK RECOIL SPRING CYLINDER ADJUSTER, LEFT

序号 NO.	代 号 PART NO.	名 称 NAME	数量 Q' TY	备注 REMARK
1	1T17043	套筒	1	
2	1T17044	压板	1	
3	1T17045	钢丝绳组件	1	
4	1T16005	左张紧缸筒	1	
5	1T17051	压环	1	
6	1T17052	油缸密封组件	1	
7	1T17056	螺纹套	1	
8	1T17057	外导向套	2	
9	1T17058	内导向套	4	
10	1T17059	活塞套	1	
11	1T17060	弹簧座	1	
12	1T17061	张紧弹簧	1	
13	1T17062	活塞	1	
14	0T16084	放油塞	1	
15	0A23109	油咀	1	
16	0A23093	密封垫	2	
17	1T17063	锁板	2	
1	GB5783—86	螺栓 M10×35	1	
2	GB93—87	垫圈 10	1	
3	GB894.1—86	挡圈 10	1	
4	GB308—77	钢球 12	1	
5	GB5783—86	螺栓 M20×50	4	
6	GB93—87	垫圈 20	4	

1T17000 右行走系统 RIGHT UNDERCARRIAGE SYSTEM

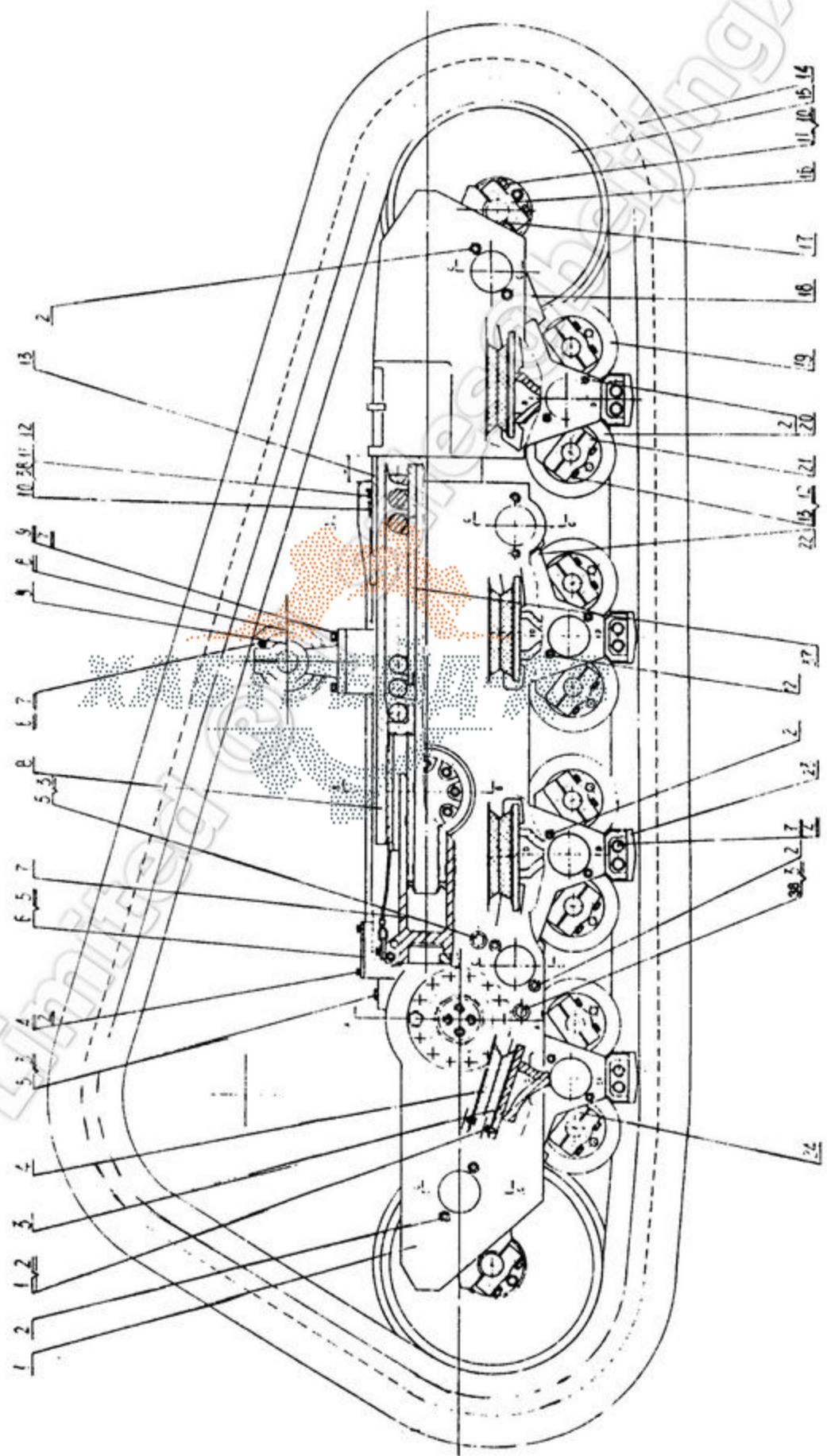

1T17000 右行走系统 RIGHT UNDERCARRIAGE SYSTEM

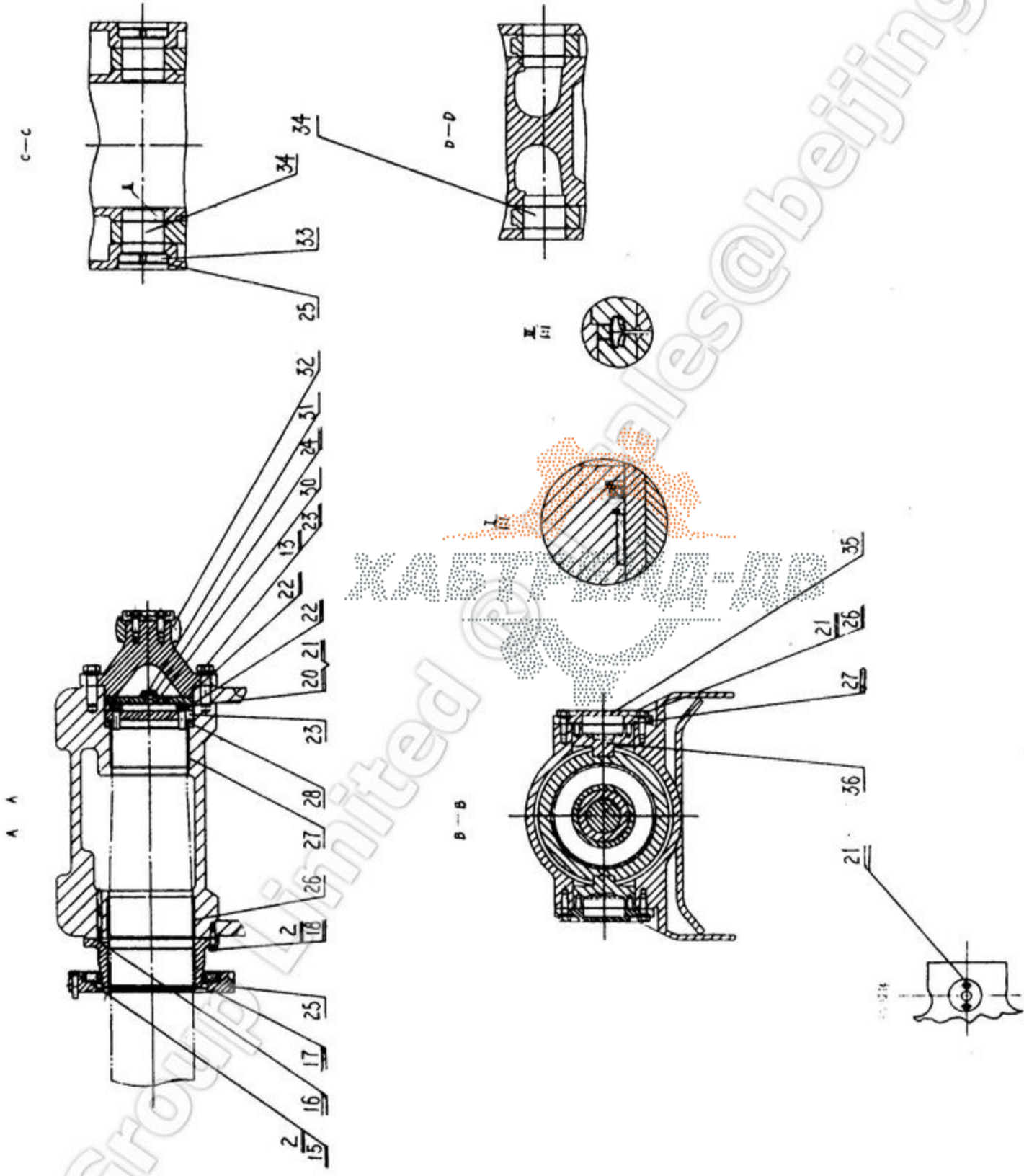

1T17000 右行走系统 RIGHT UNDERCARRIAGE SYSTEM

序号 NO.	代 号 PART NO.	名 称 NAME	数量 Q'TY	备注 REMARK
1	1T17136	右行走架焊接	1	
2	1T17163	螺堵	32	
3	1T17036	后摆架	1	
4	1T17127	橡胶减振组件	8	
5	1T17162	油塞	2	
6	1T17124	盖组件	1	
7	1T17042	右履带张紧装置	1	
8	1T17001	叉头	1	
9	1T17130	托轮座	1	
10	1T17180	大衬套	1	
11	1T17181	密封组件	1	
12	1T17179	外挡环	1	
13	1T17073	导向套	1	
14	1T17165	履带总成 228.6—560—43	1	
15	1T17096	引导轮	2	
16	1T17038	引导轮压盖组件	4	
17	1T17041	半衬套	4	
18	1T17026	前摆架	1	
19	1T17084	单边支重轮总成	4	
20	1T17092	双边支重轮总成	4	
21	1T17035	支重轮压盖组件	16	

1T17000 右行走系统 RIGHT UNDERCARRIAGE SYSTEM

序号 NO.	代 号 PART NO.	名 称 NAME	数量 Q' TY	备注 REMARK
22	1T17032	中摆架	MOVING CARRIER MIDDLE	2
23	1T17164	护块	BLOCK	8
24	1T17034	小摆架	MOVING CARRIER	8
25	1T17064	连接盘组件	CONNECTING PLATE GROUP	1
26	1T17160	大衬套	BUSH	1
27	1T17161	小衬套	BUSH	1
28	1T17114	隔环	SPACER	1
29	1T17115	压盘	PRESS PLATE	1
30	1T17116	盖	COVER	1
31	1T17117	螺塞	SCREW PLUG	1
32	1T17118	球座组件	BALL BRACKET GROUP	1
33	1T17113	堵盖	PLUG	8
34	1T17074	润滑销轴	LUBRICANT PIN	16
35	1T17122	盖	COVER	2
36	1T17123	定位键	DETENT KEY	2
37	1T17178	内挡环	RETAINER	1
38	1T17201	油塞	OIL PLUG	1
1	GB5783—86	螺栓 M12×25	BOLT M12×25	32
2	GB93—87	垫圈 12	WASHER 12	52
3	GB3452.1-82	O 形圈 33.5×3.55	O—RING 33.5×3.55	3
4	GB5783—86	螺栓 M12×30	BOLT M12×30	4
5	GB3452.1-82	O 形圈 145×5.3	O—RING 145×5.3	1
6	GB5782—86	螺栓 M20×80	BOLT M20×80	2
7	GB93—87	垫圈 20	WASHER 20	21

1T17000 右行走系统 RIGHT VNDERCARRIAGE SYSTEM

序号 NO.	代 号 PART NO.	名 称 NAME	数量 Q'TY	备注 REMARK
8	JB2984—81	托链轮	1	
9	GB5783—86	螺栓 M20×50	4	
10	GB5782—86	螺栓 M30×120—10.9	8	
11	GB93—87	垫圈 30	9	
12	GB5782—86	螺栓 M24×90—10.9	32	
13	GB93—87	垫圈 24	46	
14	GB5783—86	螺栓 M20×55	16	
15	GB5782—86	螺栓 M12×60	8	
16	GB3452.1-82	O 形圈 250×5.3	1	
17	GB3452.1-82	O 形圈 300×5.3	1	
18	GB5783—86	螺栓 M12×40	8	
20	GB5783—86	螺栓 M16×50	12	
21	GB93—87	垫圈 16	24	
22	GB3452.1-82	O 形圈 200×5.3	2	
23	GB5783—86	螺栓 M24×80—10.9	14	
24	GB3452.1-82	O 形圈 20×3.55	1	
25	GB893.2—86	挡圈 120	8	
26	GB5783—86	螺栓 M16×45	12	
27	GB3452.1-82	O 形圈 155×3.55	2	

1T17042 右履带张紧装置

TRACK RECOIL SPRING CYLINDER ADJUSTER, RIGHT

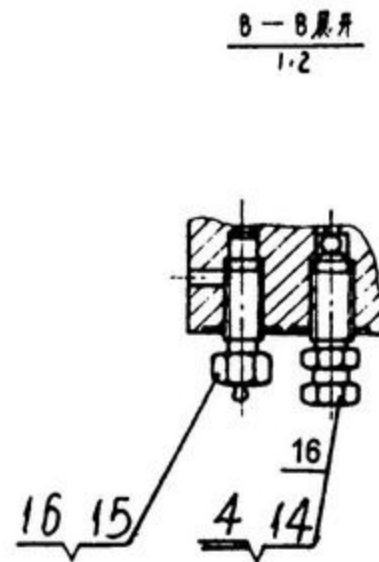
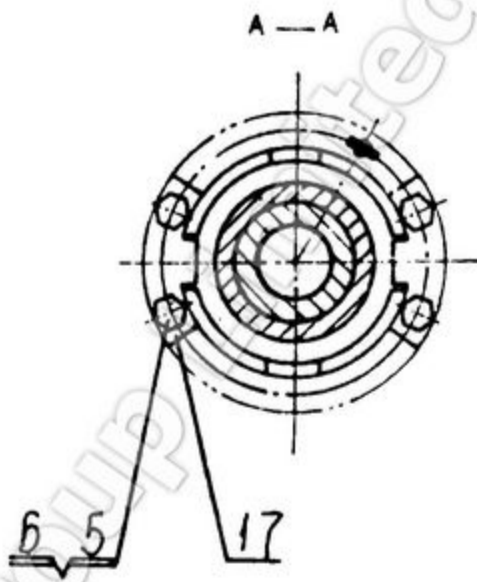
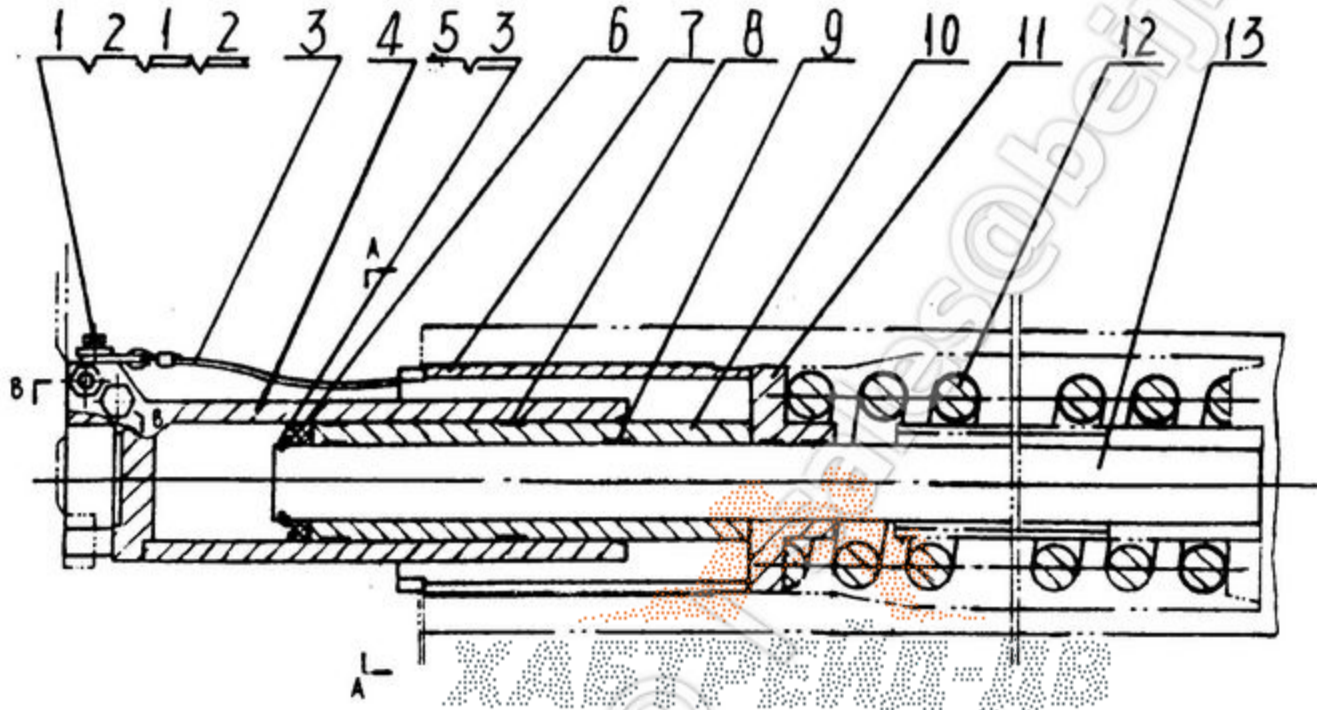

1T17042 右履带张紧装置

TRACK RECOIL SPRING CYLINDER ADJUSTER, RIGHT

序号 NO.	代 号 PART NO.	名 称 NAME	数量 Q'TY	备注 REMARK
1	1T17043	套筒	1	
2	1T17044	压板	1	
3	1T17045	钢丝绳组件	1	
4	1T17048	右张紧缸筒	1	
5	1T17051	压环	1	
6	1T17052	油缸密封组件	1	
7	1T17056	螺纹套	1	
8	1T17057	外导向套	2	
9	1T17058	内导向套	4	
10	1T17059	活塞套	1	
11	1T17060	弹簧座	1	
12	1T17061	张紧弹簧	1	
13	1T17062	活塞	1	
14	0T16084	放油塞	1	
15	0A23109	油咀	1	
16	0A23093	密封垫	2	
17	1T178063	锁板	2	
1	GB5783—86	螺栓 M10×35	1	
2	GB93—87	垫圈 10	1	
3	GB894.1—86	挡圈 75	1	
4	GB308—77	钢球 12	1	
5	GB5783—86	螺栓 20×50	4	
6	GB93—87	垫圈 20	4	

1T17064 连接盘组件 CONNECTING PLATE GROUP

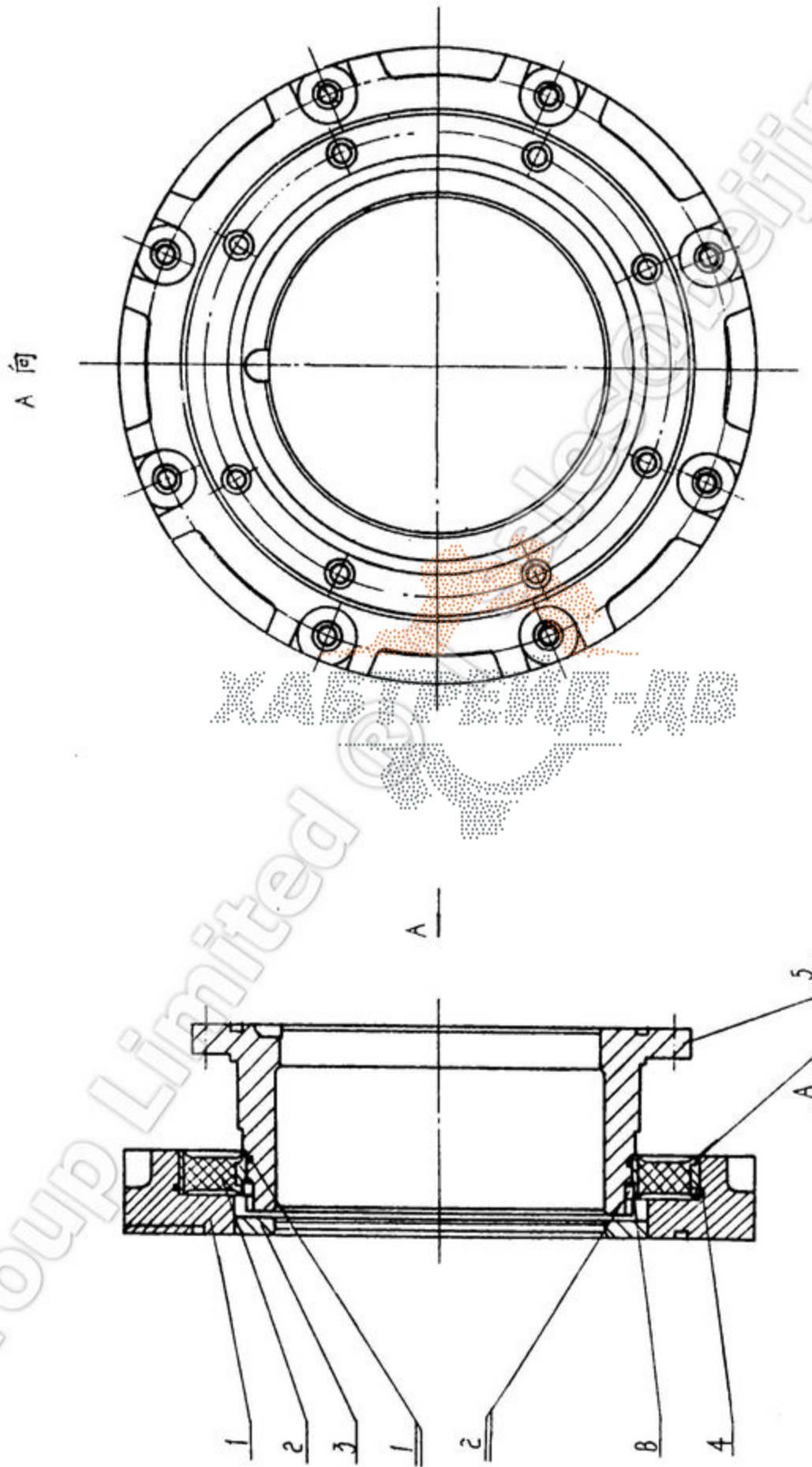

1T17064 连接盘组件 CONNECTING PLATE GROUP

序号 NO.	代 号 PART NO.	名 称 NAME	数量 Q'TY	备注 REMARK
1	1T17065	外套 OUTER SLEEVE	1	
2	1T17066	橡胶组件 RUBBER GROUP	1	
3	1T17070	隔板 BAFFLE	1	
4	1T17071	O 形圈 O-RING	1	
		328×5.3 328×5.3		
5	1T17072	内套 INNER SLEEVE	1	
1	GB3452.1-82	O 形圈 O-RING	1	
		237×5.3 237×5.3		
2	GB119-86	销 A6×8 PIN A6×8	4	

1T17084 单边支重轮总成
SINGLE FLANGE TRACK ROLLER

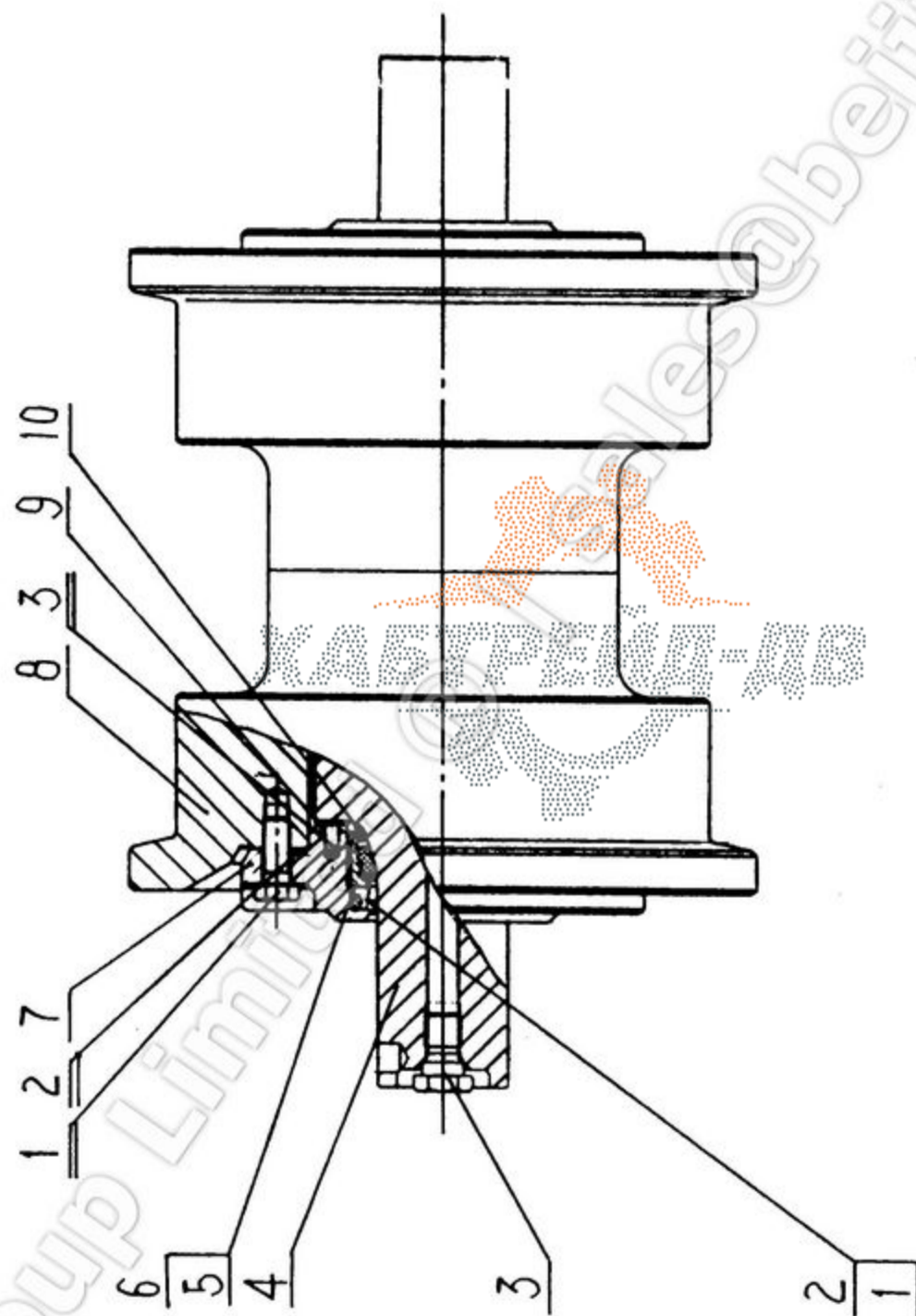

1T17084 单边支重轮总成
SINGLE FLANGE TRACK ROLLER

序号 NO.	代 号 PART NO.	名 称 NAME	数量 Q'TY	备注 REMARK
1	0T16205	外浮封环	2	
2	0T16206	外浮密封胶圈	2	
3	0A23135	螺塞	1	
4	1T17085	支重轮轴	1	
5	0T16204	内浮封环	2	
6	0T16203	内浮密封胶圈	2	
7	1T17086	支重轮端盖	2	
8	1T17087	单边支重轮组合件	1	
9	0T16209	端垫	2	
10	1T17166	衬环	2	
1	GB5783—86	螺栓 M12×30—10.9	12	
2	GB3452.1-82	O形密封圈 125×3.55	2	
3	GB119—86	销 D6×14	8	

1T17092 双边支重轮总成
DOUBLE FLANGE TRACK ROLLER

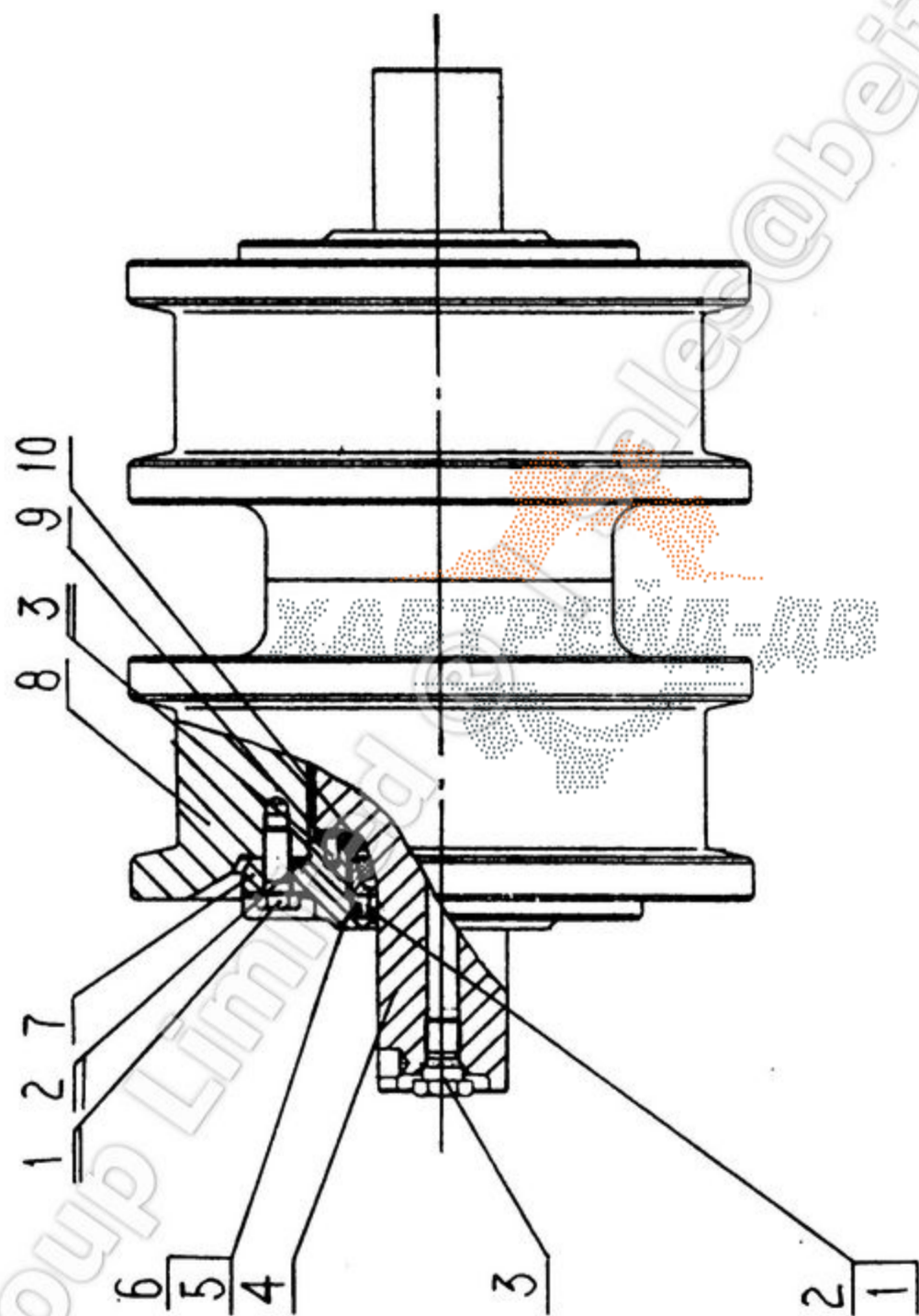

1T17092 双边支重轮总成
DOUBLE FLANGE TRACK ROLLER

序号 NO.	代 号 PART NO.	名 称 NAME	数量 Q' TY	备注 REMARK
1	0T16205	外浮封环 FLOAT SEAL RING	2	
2	0T16206	外浮密封胶圈 FLOAT RUBBER SEAL RING	2	
3	0A23135	螺塞 SCREW PLUG	1	
4	1T17085	支重轮轴 SHAFT, TRACK ROLLER	1	
5	0T16204	内浮封环 FLOAT SEAL RING	2	
6	0T16203	内浮密封胶圈 FLOAT RUBBER SEAL RING	2	
7	1T17086	支重轮端盖 END COVER	2	
8	1T17093	双边支重轮组合 件 DOUBLE FLANGE TRACK ROLLER GROUP	1	
9	0T16209	端垫 END GASKET	2	
10	1T17167	衬环 RING	2	
1	GB5783—86	螺栓 M12×30—10.9 BOLT M12×30—10.9	12	
2	GB3452.1-82	O形密封圈 125×3.55 O—SEAL RING 125×3.55	2	
3	GB119—86	销 D6×14 PIN D6×14	8	

1T17096 引导轮总成 TRACK IDLER ASSEM

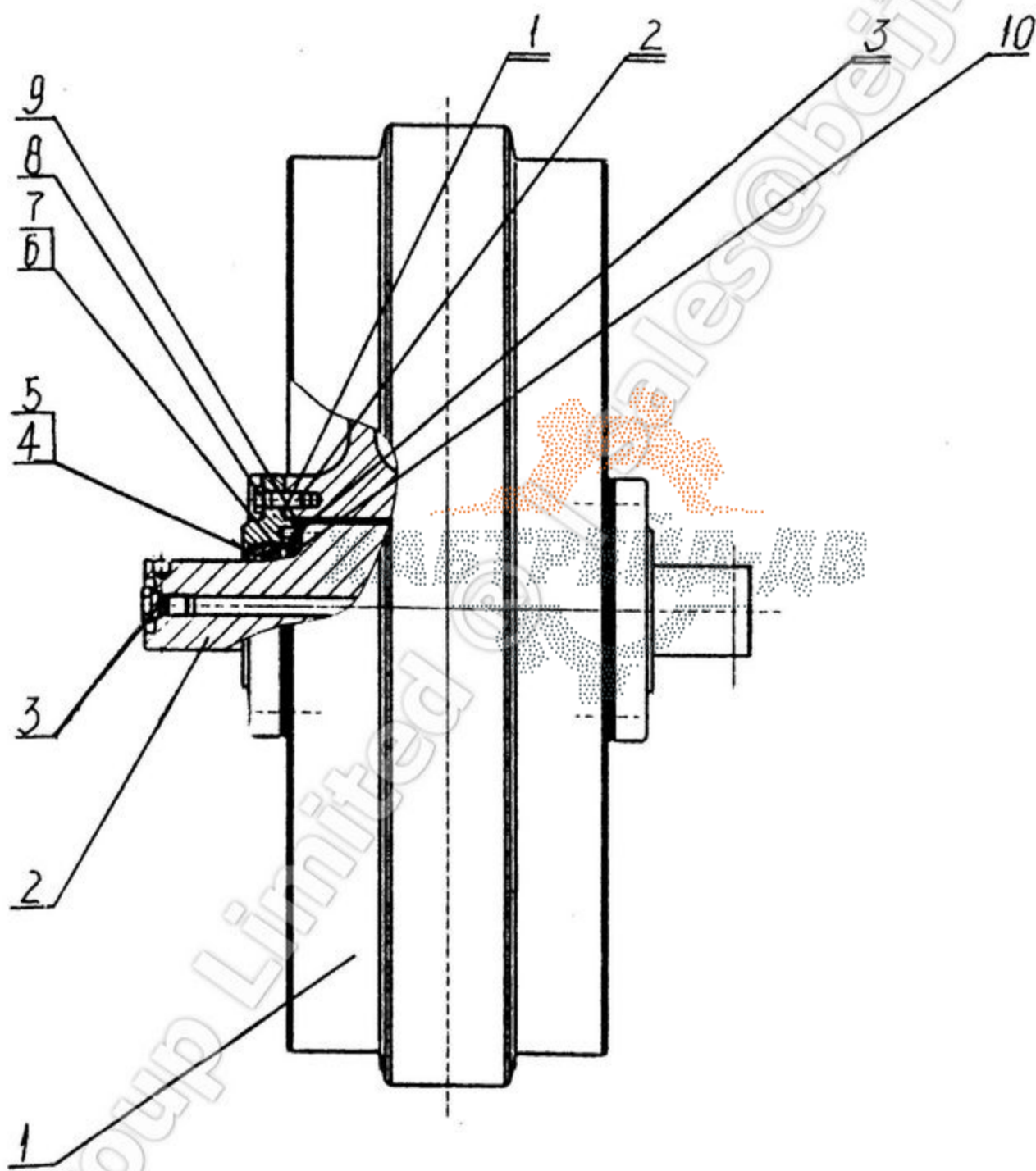

1T17096 引导轮总成 TRACK IDLER ASSEM

序号 NO.	代 号 PART NO.	名 称 NAME	数量 Q'TY	备注 REMARK
1	1T17097	引导轮组合体	1	
2	1T17104	引导轮轴	1	
3	0A23135	螺塞	1	
4	1T17105	外浮封环	2	
5	1T17106	外浮密封胶圈	2	
6	1T17107	内浮封环	2	
7	1T17108	内浮密封胶圈	2	
8	1T17109	引导轮端盖	2	
9	0T17110	端垫	2	
10	1T17167	衬环	2	
1	GB5783—86	螺栓 M12×30—10.9	12	
2	GB3452.1-82	O形密封圈 140×3.55	2	
3	GB119—86	销 D6×14	8	

1T18000 驾驶室 CAB

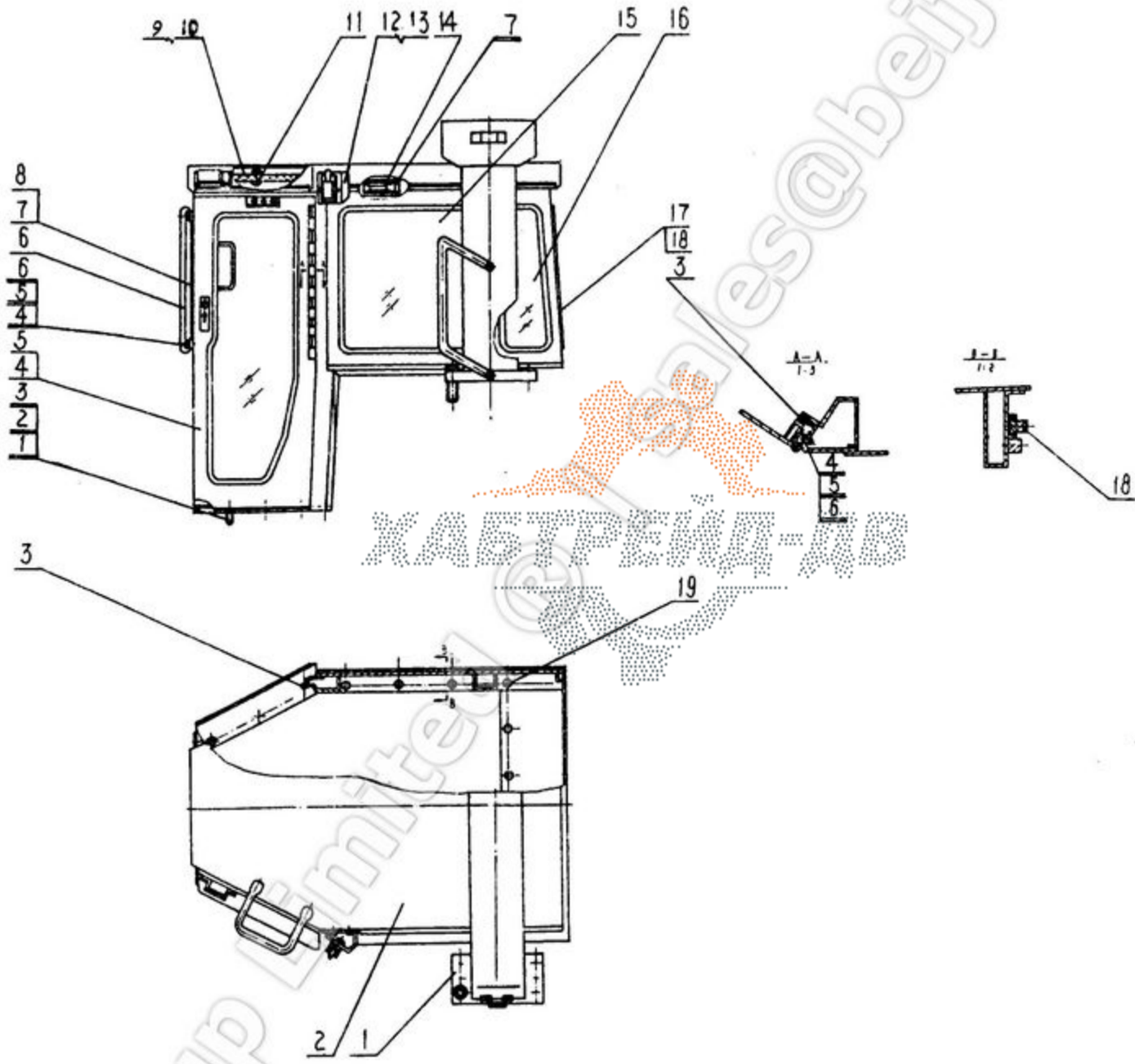

1T18000 驾驶室 CAB

序号 NO.	代 号 PART NO.	名 称 NAME	数量 Q' TY	备注 REMARK
1	1T18001	保护架	1	
2	1T18012	驾驶室体	1	
3	1T18067	门框密封条	2	
4	1T18068	左门	1	
5	1T18089	右门	1	
6	1T18093	前把手	2	
7	1T18094	前玻璃	1	
8	1T18088	玻璃密封条	1	
9	1T18095	前吸音层	1	
10	1T18096	后吸音层	1	
11	1B11315	圆螺母	11	
12	1T18097	左门固定件	1	
13	1T18115	右门固定件	1	
14	0A95060	棚灯	1	
15	1T18107	侧壁玻璃(一)	2	
16	1T18108	侧壁玻璃(二)	2	
17	0T36139	滑窗总成	1	
18	1T18110	底座密封条	1	
19	1T18113	端盖	12	
1	GB5782—86	螺栓 M10×50	18	
2	GB97.1—85	垫圈 10—200HV	18	
3	GB93—87	垫圈 10	18	
4	GB5783—86	螺栓 M12×20	16	
5	GB97.1—85	垫圈 12—200HV	16	
6	GB93—87	垫圈 12	16	
7	GB67—85	螺钉 M5×12	4	

1T19000 燃油系统 FUEL SYSTEM

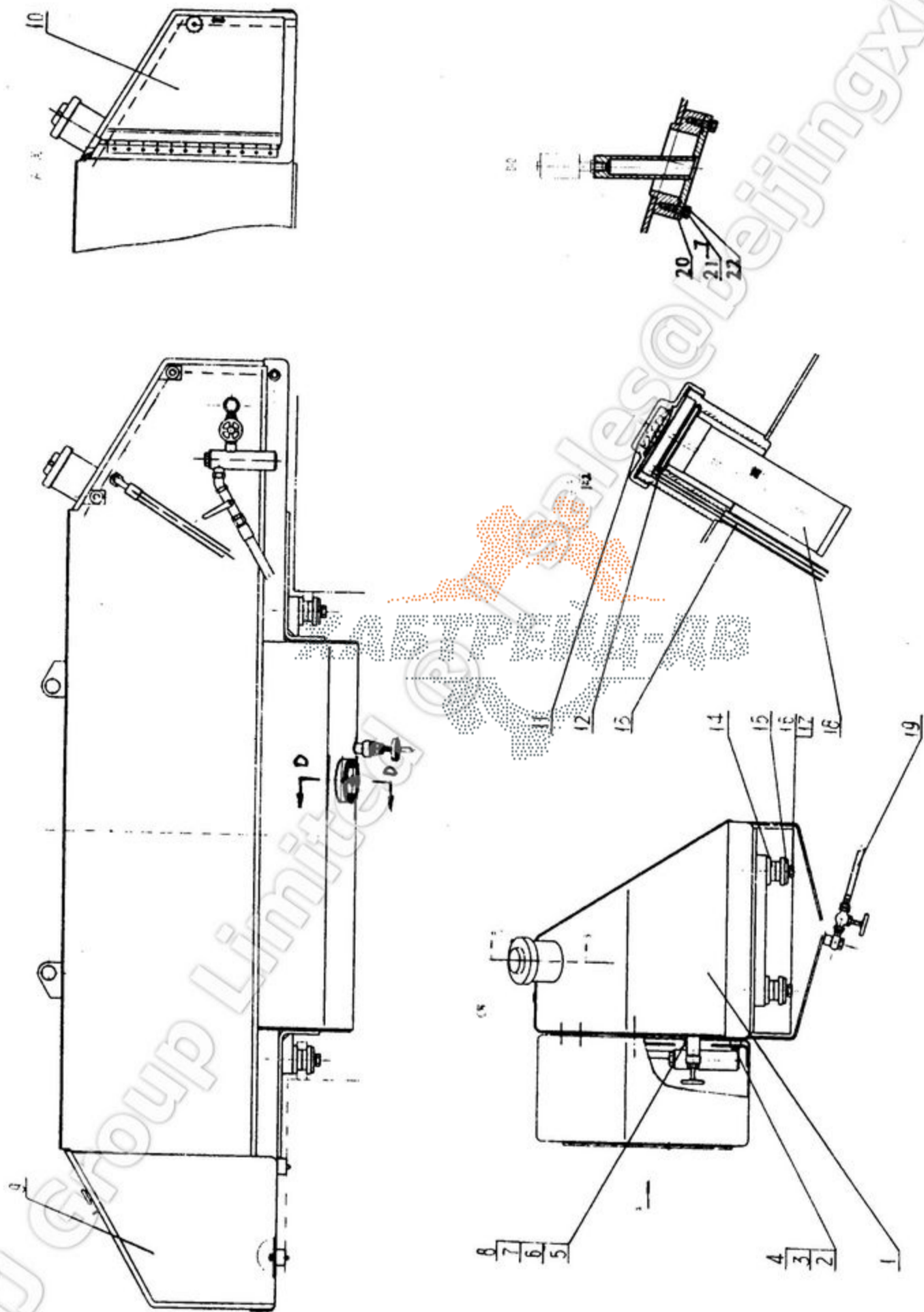

1T19000 燃油系统 FUEL SYSTEM

序号 NO.	代 号 PART NO.	名 称 NAME	数量 Q' TY	备注 REMARK
1	1T19001	箱体 HOUSING	1	
2	GB5783—86	螺栓 M10×25 BOLT M10×25	8	
3	GB93—87	垫圈 10 WASHER 10	8	
4	GB97.1—85	垫圈 10 WASHER 10	8	
5	GB5783—86	螺栓 M8×25 BOLT M8×25	2	
6	GB6170—86	螺母 M8—8 NUT M8—8	2	
7	GB93—87	垫圈 8 WASHER 8	8	
8	GB97.1—85	垫圈 8 WASHER 8	2	
9	1T19062	工具箱 TOOLBOX	1	
10	1T19031	护罩 GUARD HOUSING	1	
11	0A25011	加油盖 FILLER CAP	1	
12	0A25001	卡环 JAM RING	1	
13	1T19042	油尺 DIPSTICK	1	
14	0T19041	减震块 BUMPER BLOCK	8	
15	0T19001	垫圈 WASHER	4	
16	GB5782—86	螺栓 M20×85 BOLT M20×85	4	
17	GB93—87	垫圈 20 WASHER 20	4	
18	0A25038	滤管装配 FILTER LINE ASSEM.	1	
19	1T19043	燃油管路 FVEL LINES	1	
20	1T19078	堵盖组件 COVER	1	
21	GB5783—86	螺栓 M8×20 BOLT M8×20	6	
22	GB3452.1-92	O形圈 Ø90×3.55 O—SEAL RING	1	

1T19043 燃油管路 FUEL LINES

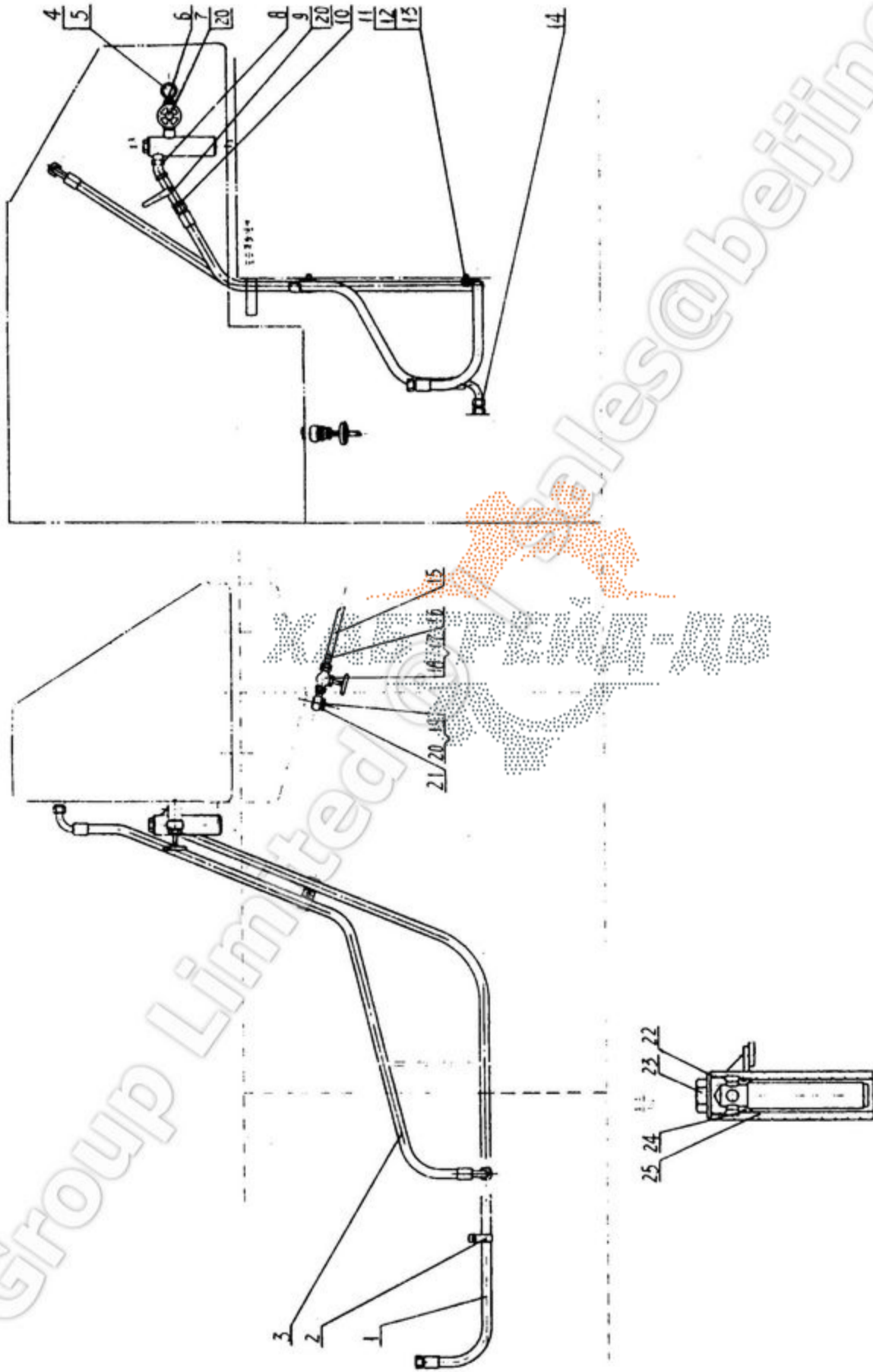

1T19043 燃油管路 FUEL LINES

序号 NO.	代 号 PART NO.	名 称 NAME	数量 Q'TY	备注 REMARK
1	0T46004	进油管	1	
2	0T46033	夹子	1	
3	0T46009	回油管	1	
4	0T46002	油塞	1	
5	0T46003	铝垫	2	
6	0T46001	接头	1	
7	0T46034	手轮式节门 1/2	1	
8	1T19060	进油管接头	1	
9	0T46037	球节门 1/2	1	
10	0T46036	接头	1	
11	GB5783—86	螺栓 M10×20	2	
12	GB93—87	垫圈 10	2	
13	1B27009	夹子	1	
14	1T19058	回油管接头	1	
15	0A25010	放油管	1	
16	0A25006	放油管接头	1	
17	0A25046	手轮式节门 3/8"	2	
18	0A01010	垫片	2	
19	0A25004	接头	1	
20	0A09021	垫片	6	
21	0A09020	油塞	1	
22	GB3452.1-92	O形密封圈 37.5×3.55	1	
23	0T46030	粗滤器	1	
24	GB3452.1-92	O形密封圈 31.5×3.55	1	
25	1T19076	滤筒焊接	1	

1T20000 松土装置 RIPPER ASS'Y

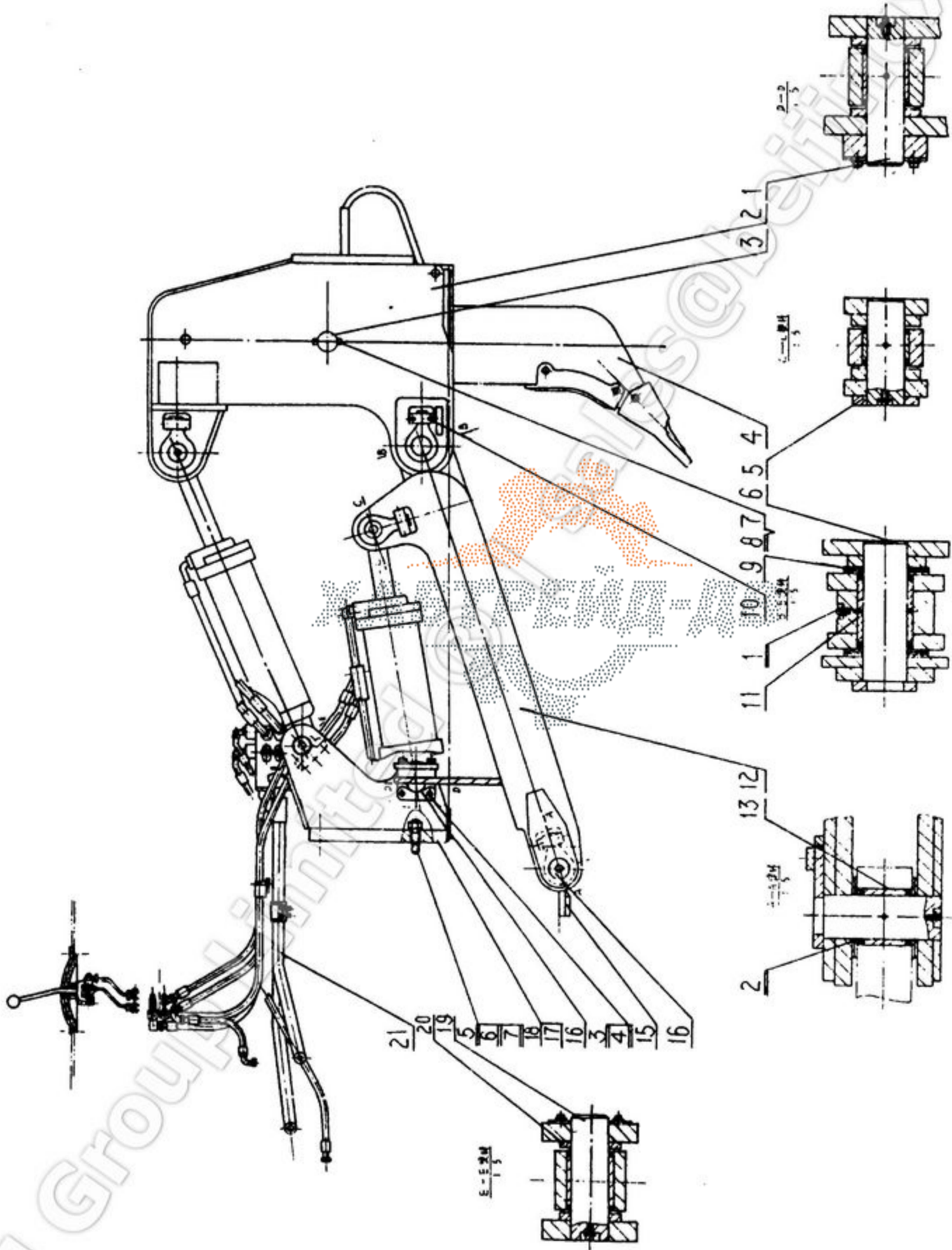

1T20000 松土装置 RIPPER ASS'Y

序号 NO.	代 号 PART NO.	名 称 NAME	数量 Q' TY	备注 REMARK	
1	1T20001	销轴	PIN	2	
2	1T20002	松土架	RIPPER SUPPORT	1	
3	1T20035	销轴	PIN	1	
4	1T20036	松土铲	RIPPER BLADE	1	
5	1T20043	板轴(一)	SHAFT(一)	4	
6	1T20046	板轴(二)	SHAFT(二)	2	
7	1T20048	销	PIN	2	
9	1T20050	调整垫	SHIM	20	
10	0T31025	压板	PLATE	8	
11	1T20051	轴套	SLEEVE	2	
12	1T20052	下连接架	LINKAGE, LOWER	1	
13	1T20070	轴套	SLEEVE	2	
14	1T20071	板轴(三)	SHAFT(三)	2	
15	1T20073	护板组件	PLATE GROUP	1	
16	1T20085	卡板	PLATE	4	
17	1T20086	左支座	SUPPORT, LEFT	1	
18	1T20093	右支座	SUPPORT, RIGHT	1	
19	1T20097	销轴	PIN	2	
20	1T20098	隔套	BAFFLE	8	
21	1T20100	松土液压操纵系 统	RIPPING HYDRAULIC CONTROL SYSTEM	1	
1	GB1152—89	油杯 M10×1	OIL CUP M10×1	14	
2	JB/ZQ3788-86	密封圈 C—1—95	SEAL RING SEAL RING C—1—95	8	
3	GB5782—86	螺栓 M16×40	BOLT M16×40	24	
4	GB93—87	垫圈 16	WASHER 16	24	
5	GB898—88	螺柱 AM36×95 —8.8—ZnD	BOLT AM36×95—8.8—ZnD	20	
6	GB6170—86	螺母 36	NUT 36	20	
7	GB93—87	垫圈 36	WASHER 36	20	
8	GB91—86	销 6.3×35	PIN 6.3×35	2	

1T20100 松土液压操纵系统
 RIPPING HYDRAULIC CONTROL SYSTEM

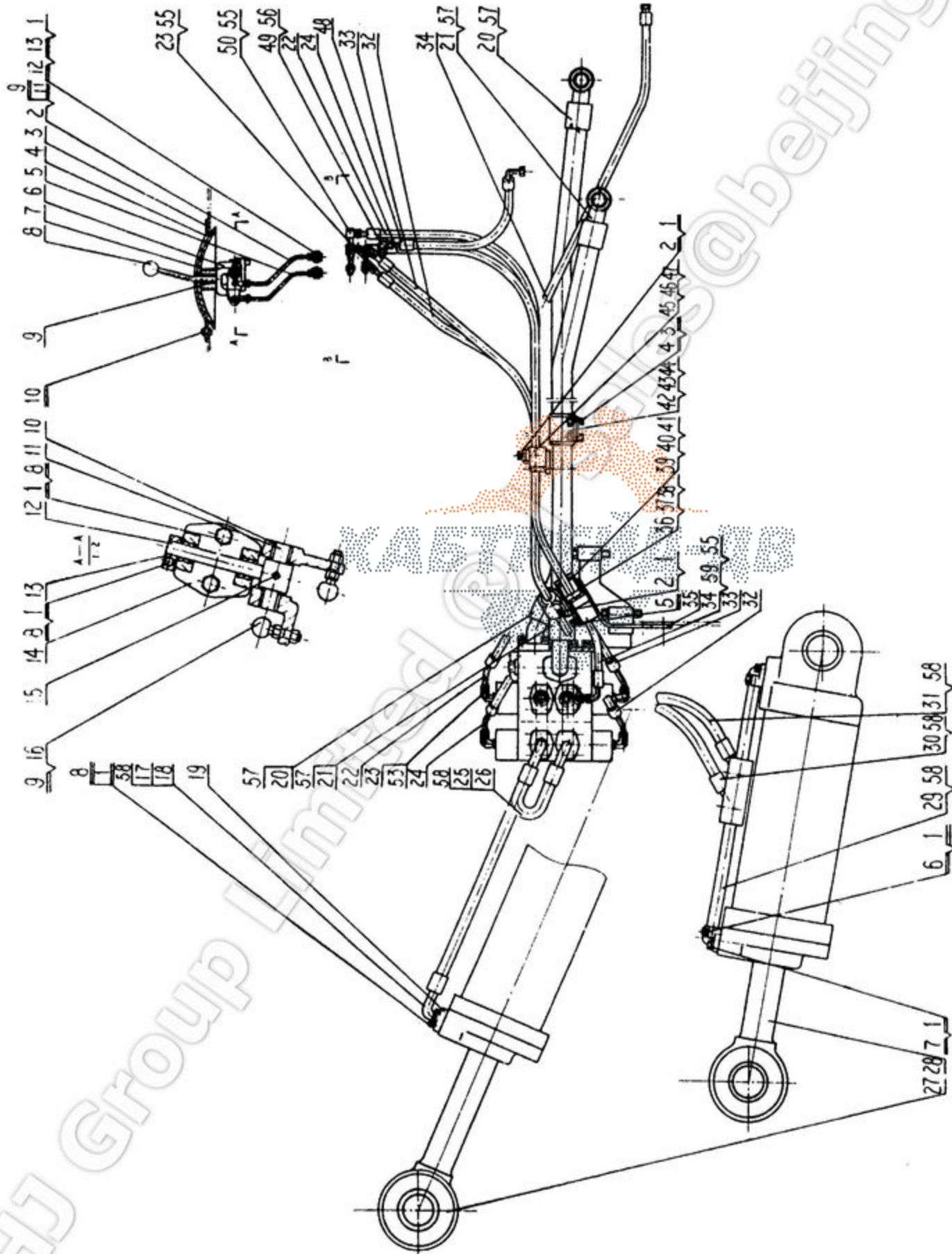

1T20100 松土液压操纵系统
RIPPING HYDRAULIC CONTROL SYSTEM

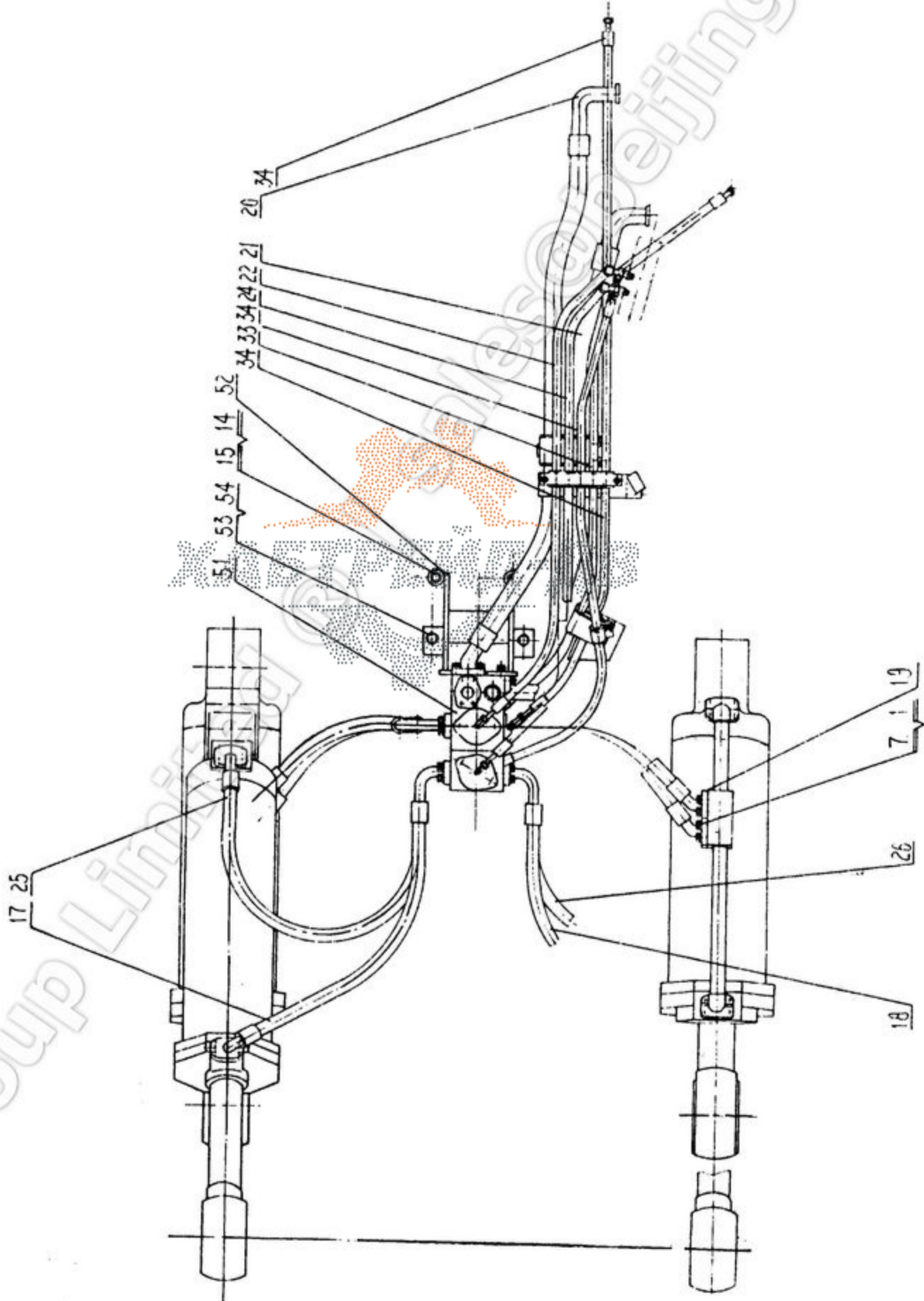

1T20100 松土液压操纵系统
RIPPING HYDRAULIC CONTROL SYSTEM

序号 NO.	代 号 PART NO.	名 称 NAME	数量 Q' TY	备注 REMARK
1	0A03001	叉头	2	
2	1T13119	连杆(二)	1	
3	1T20101	罩盖	1	
4	0F23005	内罩	1	
5	1T20102	转角连杆	1	
6	1T20120	摆架组件	1	
7	1B09059	弹簧	1	
8	0A03042	手柄	1	
9	1T13102	护套	1	
10	0A14035	小套	4	
11	0F23017	销轴	1	
13	0T31076	转轴	1	
13	0T31084	挡块	1	
14	0T13141	转轴座	1	
15	0F23018	铁丝 $\varnothing 3 \times 3.5$	1	
16	1T13107	关节轴承组件	2	
17	1T20123	左转角杆腔软管	1	
18	1T20127	右转角杆腔软管	1	
19	0T31110	压盖	16	
20	1T20128	泵油管	1	
21	1T20133	回油管	1	
22	1T20137	提升阀上控制软管	1	
23	1B01524	直角弯头组件	6	
24	1T20143	转角阀上控制软管	1	

1T20100 松土液压操纵系统
RIPPING HYDRAULIC CONTROL SYSTEM

序号 NO.	代 号 PART NO.	名 称 NAME	数量 Q'TY	备注 REMARK
25	1T20145	左转角底腔软管	1	
26	1T20147	右转角底腔软管	1	
27	1T20200	转角油缸	2	
28	1T20250	提升油缸	2	
29	1T20162	硬管组件	2	
30	1T20148	提升杆腔软管	2	
31	1T20151	提升底腔软管	2	
32	1T20153	转角阀下控制软管	1	
33	1T20155	提升阀下控制软管	1	
34	1T20157	辅助液控软管	1	
35	1T20166	弯支架	1	
36	1B10007	上夹板	1	
37	1B10008	下夹板	1	
38	1T20104	胶套	1	
39	1T20105	双管上夹板	1	
40	1T20106	双管下夹板	1	
41	1T20107	双管胶套	1	
42	1T20108	大双管上夹板	1	
43	1T20109	大双管下夹板	1	
44	1T20110	大双管胶套	1	
45	1T20169	支座	1	
46	1T20111	压板	1	
47	1T20112	五管胶套	1	
48	1T20160	压力控制软管	1	

1T20100 松土液压操纵系统
RIPPING HYDRAULIC CONTROL SYSTEM

序号 NO.	代 号 PART NO.	名 称 NAME	数量 Q' TY	备注 REMARK
49	1T20172	直角弯头组件	1	
50	1T13034	长直角弯头组件	2	
51	1T20300	松土操纵阀	1	
52	1T20176	松土阀支架	1	
53	1B09023	螺栓	4	
54	1B01407	垫圈	4	
55	1B01382	O形密封圈	9	
56	1B01429	O形密封圈	1	
57	1B01418	O形密封圈	4	
58	1B08057	O形密封圈	20	
59	1T20103	接头体	1	
1	GB97.1—85	垫圈 10	55	
2	GB5783—86	螺栓 M10×25	3	
3	GB97.1—85	垫圈 12	2	
4	GB5783—86	螺栓 M12×25	2	
5	GB5783—86	螺栓 M10×20	1	
6	GB5782—86	螺栓 M10×45	8	
7	GB5782—86	螺栓 M10×30	24	
8	GB5782—86	螺栓 M10×35	19	
9	GB6170—86	螺母 M10×1.25	4	
10	GB818—85	螺钉 M8×16	4	
11	GB6170—86	螺母 M8	2	
12	GB882—86	销 6×22	2	
13	GB91—86	销 2×10	2	
14	GB5782—86	螺栓 M16×90	4	
15	GB97.1—85	垫圈 16	4	

1T20200 转角油缸 TIP CYLINDER

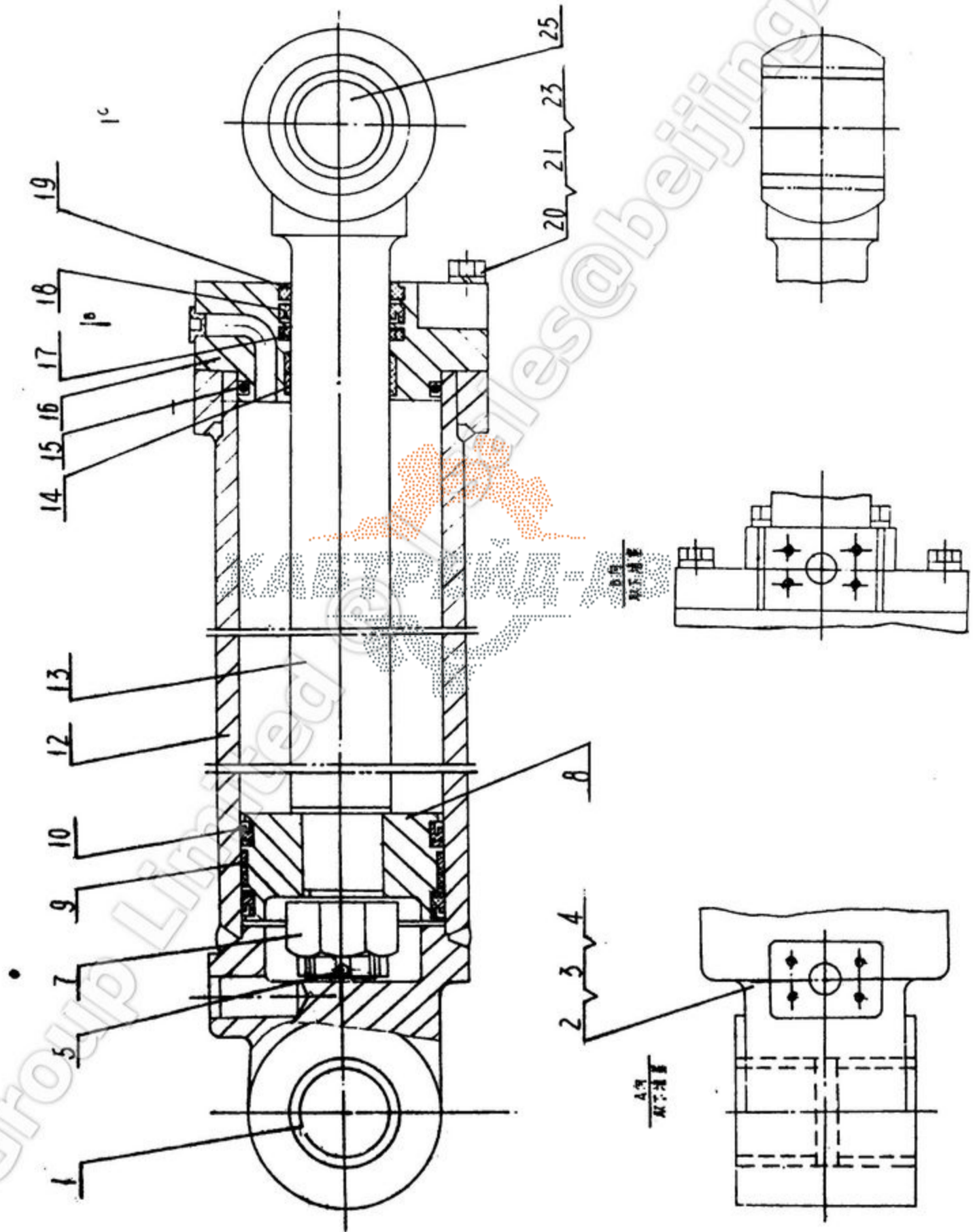

1T20200 转角油缸 TIP CYLINDER

序号 NO.	代 号 PART NO.	名 称 NAME	数量 Q' TY	备注 REMARK
1	X05—1	轴套	1	
2	X01—6	护垫	2	
3	SGA01—9	垫板	2	
4	GB5783—86	六角头螺钉 M10	4	
5	GB91—86	开口销 $\varnothing 5 \times 70$	1	
7	XH05—2	螺母	1	
8	XH07—2	活塞	1	
9	CKW1800	格来圈	1	
10	HG24—2	导向环	2	
11	GB3452.1-82	O 形圈 35505800	1	
12	XH0701	缸体组件	1	本部件为
13	XH0702	活塞杆组件	1	外配套件
14	TGB302—8	导向环	2	图号名称
15	GB3452.1-82	O 形圈 70016500	1	以配套厂
16	XH07—3	导向套	1	为准
17	CKS—0800	斯特封	1	
18	yxd (80 × 92 × 14)	yx 型轴用密封圈	1	
19	CK80	CK 型防尘圈	1	
20	GB97.1—85	垫圈 24 200V	6	
21	GB5782—86	螺栓 M24 × 120	2	
23	GB5783—86	螺栓 M24 × 80	4	
25	XH05—8	轴套	1	

HSG—F180×597/80E 转角油缸(外配套件)
TIP CYLINDER(PURCHASED PARTS)

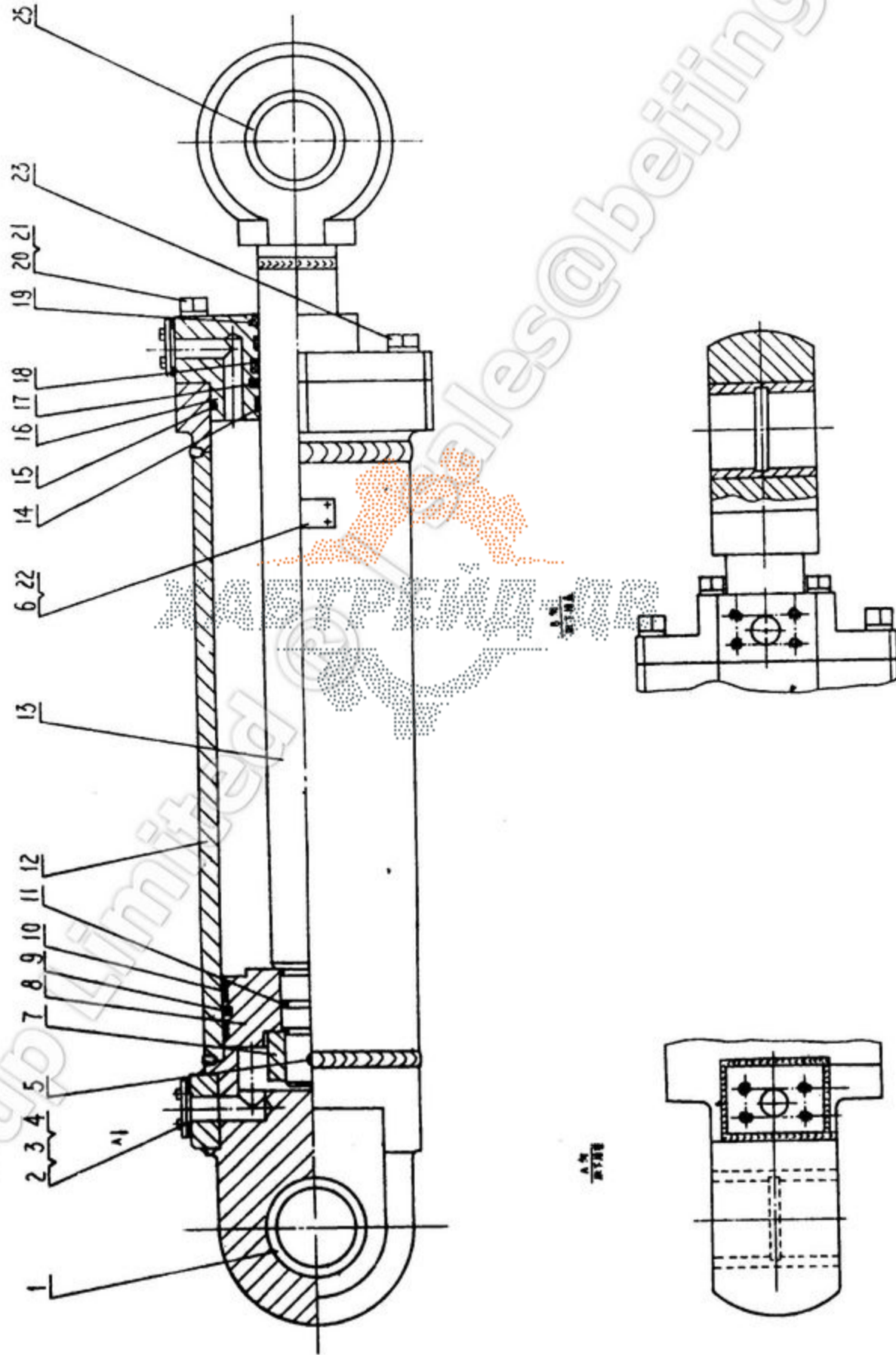

HSG—F180×597/80E 转角油缸(外配套件)

TIP CYLINDER(PURCHASED PARTS)

序号 NO.	代 号 PART NO.	名 称 NAME	数量 Q' TY	备注 REMARK
1	X05—1	轴套	1	
2	X01—6	护垫	2	
3	SGA01—9	垫板	2	
4	GB5783—86	六角头螺钉 M10	4	
5	GB91—86	开口销 $\varnothing 5 \times 70$	1	
6	XH07—1	铭牌	1	
7	XH05—2	螺母	1	
8	XH07—2	活塞	1	
9	CKW1800	格来圈	1	
10	HG24—2	导向环	2	
11	GB3452.1-82	O形圈 35505800	1	O—RING 35505800
12	XH0701	缸体组件	1	
13	XH0702	活塞杆组件	1	
14	TGB302—8	导向环	2	
15	GB3452.1-82	O形圈 70016500	1	O—RING 70016500
16	XH07—3	导向套	1	
17	CKS—0800	斯特封	1	
18	yxd (80 × 92 ×14)	yx 型轴用密封圈	1	YX TYPE SEAL RING
19	CK80	CK 型防尘圈	1	CK TYPE DUST PROOF RING
20	GB97.1—85	垫圈 24 200V	6	WASHER 24 200V
21	GB5782—86	螺栓 M24×120	2	BOLT M24×120
22	GB827—86	铆钉 3×3	4	RIVET 3×3
23	GB5783—86	螺栓 M24×80	4	BOLT M24×80
25	XH05—8	轴套	1	

1T20250 提升油缸 LIFT CYLINDER

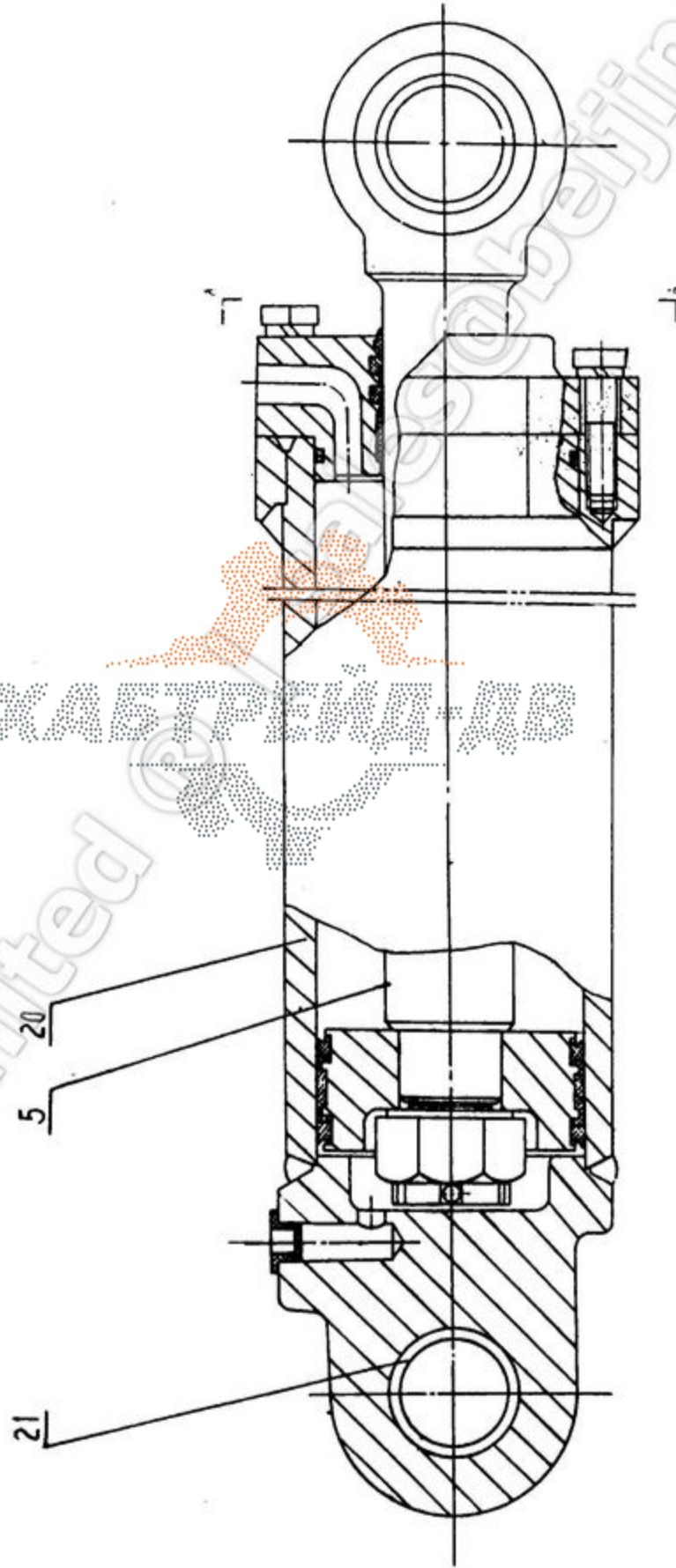

1T20250 提升油缸 LIFT CYLINDER

序号 NO.	代 号 PART NO.	名 称 NAME	数量 Q' TY	备注 REMARK	
1	GB6175—86	六角螺母 M24	NUT M24	4	
2	GB93—87	弹簧垫圈 24	SPRING 24	10	
3	XH06—1	轴承盖	COVER	1	
4	XH06—2	垫片	SHIM	18	
5	XH0601	活塞杆组件	PISTON ROD GRPUP	1	
6	GB97.2—85	平垫圈 24	WASHER 24	4	
7	GB5782—86	六角头螺栓	BOLT	4	
8	CK 75	防尘圈 d75	DUST PROOF RING d75	1	
9	XH06—3	导向环	GUIDE RING	2	
10	XH01—5	护盖	COVER	1	
11	XH01—6	护垫	GASKET	2	
12	GB5781—86	螺栓 M10×20	BOLT M10×20	2	本部件为
13	yxd75×87×14	yx 型轴用密封圈	YX TYPE SEAL RING	1	外配套件
15	GB5783—86	六角头螺栓	BOLT	4	图号名称
16	ZYS 75×6	轴用组合密封圈	SEAL RING GROUP	1	以配套厂
17	XH06—5	导向套	GUIDE SLEEVE	1	为准
18	GB3452.1-82	O 型密封圈 53011800	O—SEAL RING 53011800	1	
19	XH06—6	挡盘	PLATE	1	
20	XH0602	缸体组件	CYLINDER GROUP	1	
21	XH06—7	轴套	SLEEVE	2	
22	GB827—86	铆钉 3×3	RIVET 3×3	4	
23	XH06—8	铭牌	LABEL	1	
24	XH06—9	挡盘	PLATE	1	
25	XH01—11	滑阀	SLIDE VALVE	2	

1T20250 提升油缸 LIFT CYLINDER

序号 NO.	代 号 PART NO.	名 称 NAME	数量 Q'TY	备注 REMARK
26	XH06—10	导向环 GUIDE RING	2	
27	XH01—12	阀套 SLEEVE	4	
28	CKW 1300	孔用组合密封圈 SEAL RING	1	
29	GB3452.1-82	O 型密封圈 O—SEAL RING 35504870	1	
30	XH06—11	活塞 PISTON	1	
31	XH01—18	销轴 PIN SHAFT	2	
32	XH06—12	螺母 NUT	1	
33	GB91—86	开口销 $\varnothing 6 \times 75$ COTTER PIN $\varnothing 6 \times 75$	1	
34	GB5781—86	螺栓 M16 \times 35 BOLT M16 \times 35	2	
35	XH01—16	护盖 COVER	1	

HSG—F200×405/80E 提升油缸(外配套件)
LIFT CYLINDER(PURCHASED PARTS)

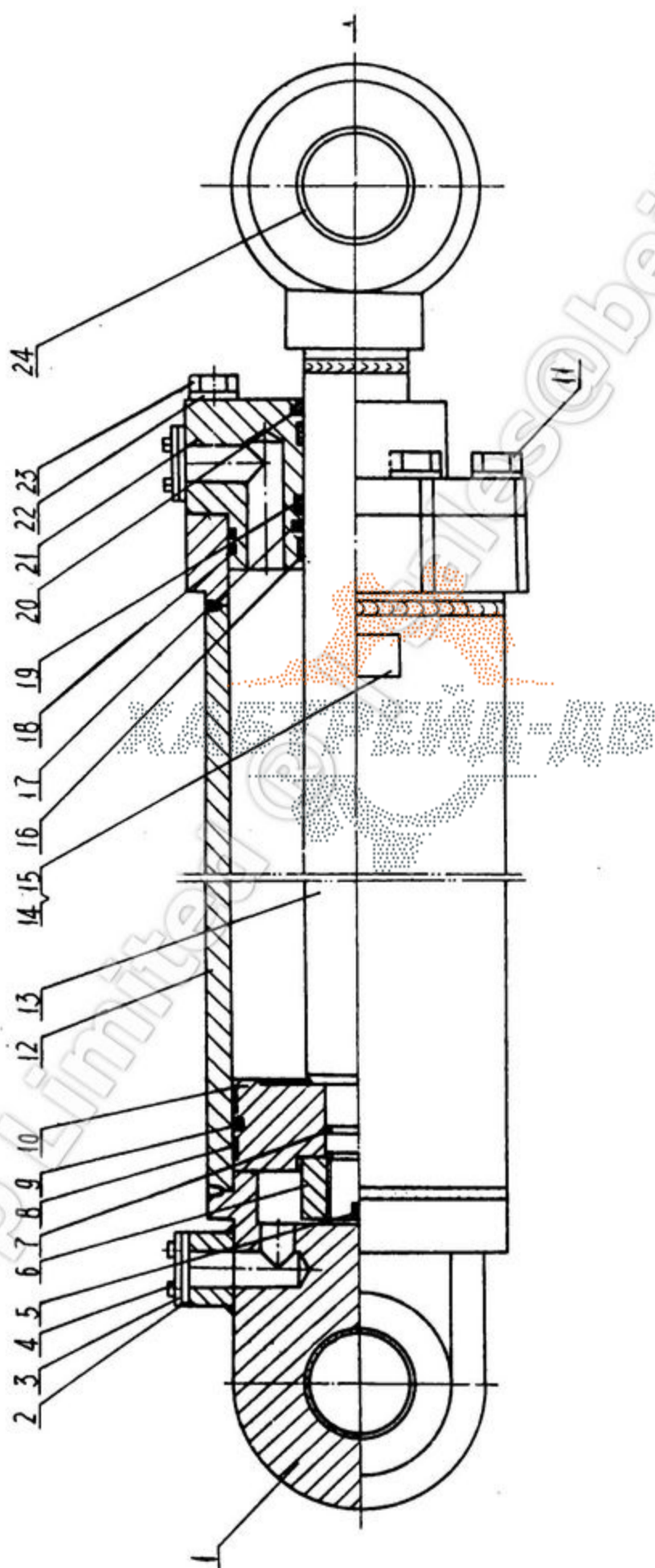

HSG—F200×405/80E 提升油缸(外配套件)

LIFT CYLINDER(PURCHASED PARTS)

序号 NO.	代 号 PART NO.	名 称 NAME	数量 Q'TY	备注 REMARK
1	XH05—1	轴套	1	
2	X01—6	护板	2	
3	XH01—5	垫板	2	
4	GB5783—86	六角头螺栓	4	
5	GB91—86	开口销 $\varnothing 6 \times 70$	1	
6	XH05—2	螺母	1	
7	GB3452.1-82	O形圈 35505800	1	
8	ZL50E02—8	导向环	2	
9	CKW2000	格来圈	1	
10	XH05—2	活塞	1	
11	GB5783—86	螺栓 M24×90	6	
12	XH0501	缸体组件	1	
13	XH0502	活塞杆组件	1	
14	XH05—6	铭牌	1	
15	GB827—86	铆钉 3×3	4	
16	ZL5001—7	导向环	2	
17	CKS—0800	轴用组合密封	1	
18	GB3452.1-82	O型密封圈 70018500	2	
19	yxd (80×92 ×14)	yx型轴用密封圈	1	
20	CK80	CK型防尘圈	1	
21	XH05—7	导向套	1	
22	GB97.2—85	垫圈 24	8	
23	GB5782—86	螺栓 M24×130	2	
24	XH05—8	轴套	1	

1T20300 松土操纵阀 RIPPER CONTROL VALVE

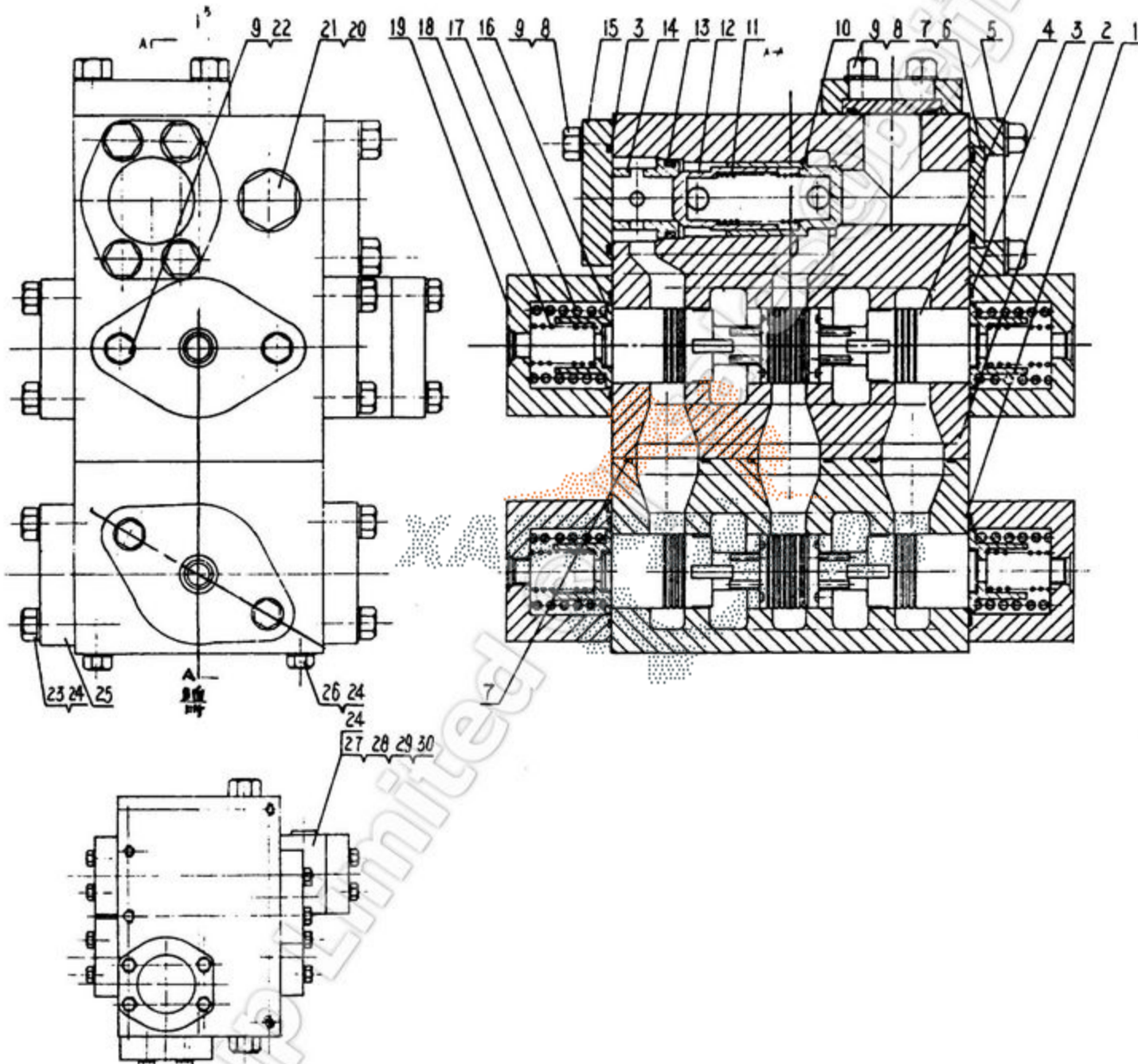

1T20300 松土操纵阀 RIPPER CONTROL VALVE

序号 NO.	代 号 PART NO.	名 称 NAME	数量 Q'TY	备注 REMARK
1	1T20301	小阀体	1	
2	1T20302	大阀体	1	
3	1T20303	O形密封圈	5	
4	1T20304	阀杆	2	
5	1B01405	压盖	6	
6	1T13010	堵板	3	
7	1B01418	O形密封圈	6	
8	1B09023	螺栓	10	
9	1B01407	垫圈	16	
10	1T20305	大锥阀芯	1	
11	1T20306	弹簧	1	
12	1T20307	小锥阀芯	1	
13	1T20316	O形密封圈	2	
14	1T20308	小锥阀座	1	
15	1T20309	盖板	1	
16	1T20310	弹簧座	4	
17	1T20311	外簧	4	
18	1T20312	内簧	4	
19	1T20313	罩盖	4	
20	1B38013	螺塞	2	
21	1B01393	O形密封圈	2	
22	1B03415	螺栓	8	
23	1B01410	螺栓	28	
24	1B03003	垫圈	36	
25	1B01378	压盖	16	
26	1T20314	螺栓	4	
27	1T20315	连接体	1	
28	1T20317	O形密封圈	1	
29	1B01424	螺塞	1	
30	1B01382	O形密封圈	1	

3G1773—XG 松土器主控阀(外配套件)
 RIPPER MAIN CONTROL VALVE(PURCHASED PARTS)

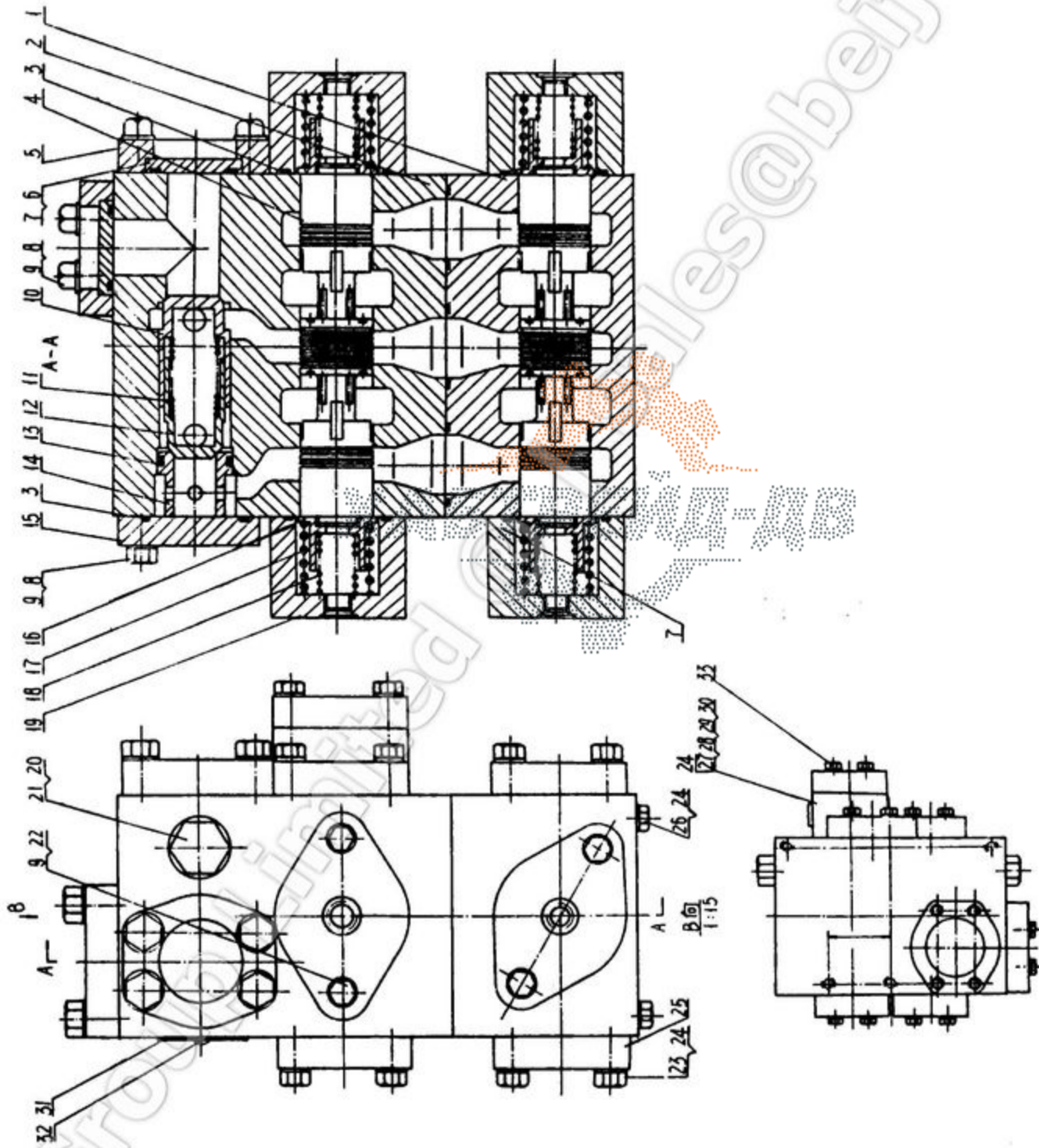

3G1773—XG 松土器主控阀(外配套件)

RIPPER MAIN CONTROL VALVE(PURCHASED PARTS)

序号 NO.	代 号 PART NO.	名 称 NAME	数量 Q'TY	备注 REMARK
1	8J8545—XG	下阀体	1	
2	9T5784—XG	阀体	1	
3	8T7268	O型密封圈	5	
4	3G1770	阀芯	2	
5	1P4578	半法兰	6	
6	5H4020—XG	盖板	3	
7	8T7212	O型密封圈	6	
8	0T0320	螺栓	14	
9	5P8244	垫圈	22	
10	8J8336	阀	1	
11	4H1718	弹簧	1	
12	8J8338	阀	1	
13	4J521	O型密封圈	1	
14	8J8497	阀座	1	
15	9J2915	盖板	1	
16	3G8439—XG	弹簧座	4	
17	1U2760	弹簧	4	
18	9J4800—XG	内簧	4	
19	9J2916	连接体	4	
20	9S4190	螺塞	2	
21	2M9780	O型密封圈	2	
22	1D4556	螺栓	8	
23	S1588	螺栓	28	
24	5M2894	垫圈	38	
25	1P4571	半法兰	16	
26	1A5964—XG	螺栓	6	
27	9J3866	连接件	1	
28	8T7211	O型密封圈	1	
29	9S4191	螺堵	1	
30	3J1907	O型密封圈	1	
31	920601	标牌	1	
32	GB827—76	标牌用钉 2×4	1	
33	L1143	螺栓	4	

1T21000 电器系统 ELECTRIC SYSTEM

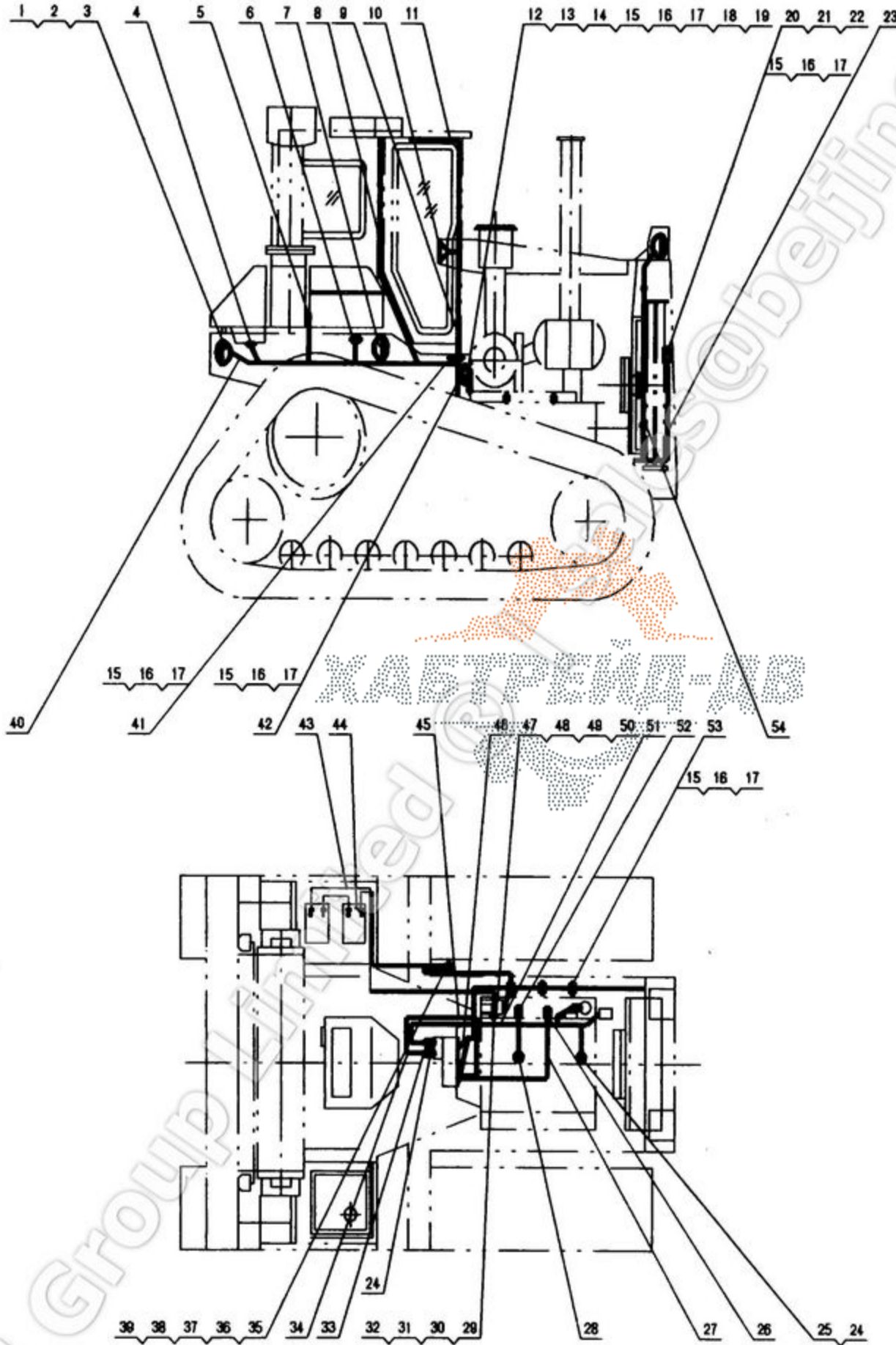

1T21000 电器系统 ELECTRIC SYSTEM

序号 NO.	代 号 PART NO.	名 称 NAME	数量 Q' TY	备注 REMARK
1	0L73004	左照明灯 (仿 CAT)	3	
2	073005	右照明灯 (仿 CAT)	3	
3	0L73007	接地线	2	
4	1T21029	燃油液位开关	1	
5	1T21030	液压油温开关	1	
6	1T21031	燃油压力开关	1	
7	1T21001	侧灯线	2	
8	1T21032	空调线束	1	
9	1T21023	仪表盘线束	1	
10	1T21033	仪表盘总成	1	
11	1T21057	棚灯线	1	
12	GB93-87	垫圈 6	2	
13	GB97.1-85	垫圈 6	2	
14	GB67-85	螺钉 M6×16	2	
15	GB93-87	垫圈 10	10	
16	GB97.1-85	垫圈 10	10	
17	GB5783-86	螺栓 M10×25	10	
18	1T21058	主继电器	1	
19	1T21059	主继电器连接板	1	
20	1T21060	喇叭	1	
21	1T21061	喇叭	1	
22	1T21062	喇叭	2	
23	1T21063	喇叭前灯线	1	
24	1T21064	接头	1	

1T21000 电器系统 ELECTRIC SYSTEM

序号 NO.	代 号 PART NO.	名 称 NAME	数量 Q' TY	备注 REMARK
25	1T21065	冷却温度开关 SWITCH	1	
26	1T21066	过渡接头 CONNECTOR	1	
27	1T21067	高压油管 2M PIPE	1	
28	1T21068	温度传感器 TEMP SENSOR	1	
29	GB67-85	螺钉 M5×20 SCREW	2	
30	GB93-87	垫圈 5 WASHER	2	
31	GB97.1-85	垫圈 5 WASHER	2	
32	GB6170-86	螺母 M5 NUT	2	
33	1T21069	传动温度开关 SWITCH	1	
34	1T21070	高压油管 2.3M PIPE	1	
35	1B03723	开关 SWITCH	1	
36	GB5783-86	螺栓 M8×25 BOLT	2	
37	GB93-87	垫圈 8 WASHER	2	
38	GB97.1-85	垫圈 8 WASHER	2	
39	GB96-85	螺母 M8 NUT	2	
40	1T21071	后线束 REAR HARNESS	1	
41	11T21072	夹子 CLIP	1	
42	1T21073	报警器 WARNING	1	
43	1T21074	电池线组 HARNESS BATTERY	1	
44	1T21081	蓄电池 680-25-MF BATTERY	2	
45	1T21082	传动油温连线 CONNECTED LINE	1	
46	1T21083	仪表线束 HARNESS	1	
47	GB93-87	垫圈 16 WASHER	1	
48	0T44030	螺栓 BOLT	1	
49	1T21084	起动继电器板 RELAY PLATE	1	

1T21000 电器系统 ELECTRIC SYSTEM

序号 NO.	代 号 PART NO.	名 称 NAME	数量 Q'TY	备注 REMARK
50	1T21085	起动继电器 RELAY STARTING	1	
51	1T21020	前线束 FRONT HARNESS	1	
52	1B03603	压力开关 PRESSURE SWITCH	1	
53	1B03632	线夹子 CLIP	3	
54	1F3003	扎带 ZD150×8 BELT	4	
55	0T22016	接头 CONNECTOR	1	
56	0T19047	垫圈 WASHER	1	
57	1T21087	接头 CONNECTOR	1	

1T21033 仪表盘总成 INSTRUMENT ASSEM.

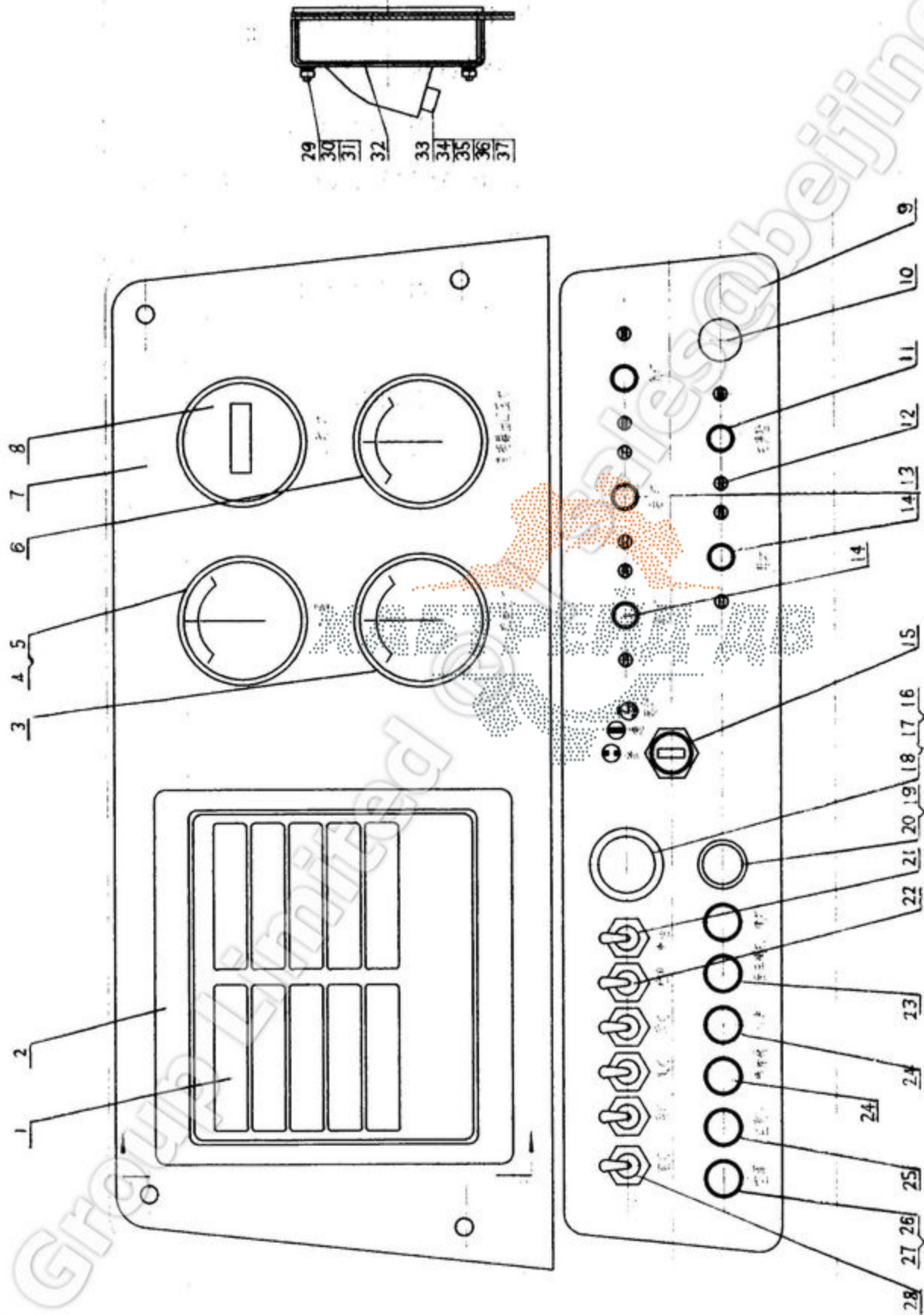

1T21033 仪表盘总成 INSTRUMENT ASSEM.

序号 NO.	代 号 PART NO.	名 称 NAME	数量 Q'TY	备注 REMARK
1	1T21034	PC 盘面 148×136	1	
2	1T21035	监控器	1	
3	1T21036	压力表 YY03004	1	
4	1T21037	冷却温度表	1	
5	1T21038	仪表灯	1	
6	1T21039	压力表 YY07004	1	
7	1T21040	盘面	1	
8	1T21041	计时器	1	
9	1T21042	PC 盘面 450×98	1	
10	1B04174	开关总成	1	
11	1B03700	断路器 60A	1	
12	1B03626	螺钉	10	
13	1T21043	断路器 10A	2	
14	1T21044	断路器 15A	2	
15	1A16028	起动开关 JK406B	1	
16	1T21045	灯座	1	
17	1T21046	盖	1	
18	1T21047	灯泡	1	
19	0H25003	指示灯(红)PL220	1	
20	0H25004	灯泡 24V-Ø4	1	
21	1T21047	开关	4	
22	1T21048	开关	1	
23	1T21049	保险芯 10A	2	
24	0T44029	保险芯 1A	2	
25	1B03624	保险芯 5A	1	

1T21033 仪表盘总成 INSTRUMENT ASSEM.

序号 NO.	代 号 PART NO.	名 称 NAME	数量 Q' TY	备注 REMARK
26	1B03625	保险芯 15A FUSE ELEMENT	1	
27	1B03688	保险丝螺塞 SCREW	6	
28	1T21050	开关 SWITCH	1	
29	1B03154	螺母 1/4-20 NUT	4	
30	GB97.1-85	垫圈 6 WASHER	4	
31	GB93-87	垫圈 6 WASHER	4	
32	1T21051	支架 SUPPORTER	2	
33	1T21052	组件 GRONP	1	
34	1T21053	套筒 SLEEVE	1	
35	1T21054	护盖 ERUARD	1	
36	1T21055	套筒 SLEEVE	1	
37	1T21056	套筒 SLEEVE	1	

1T22000 多路液控换向阀 PILOT OPERATED VALVES

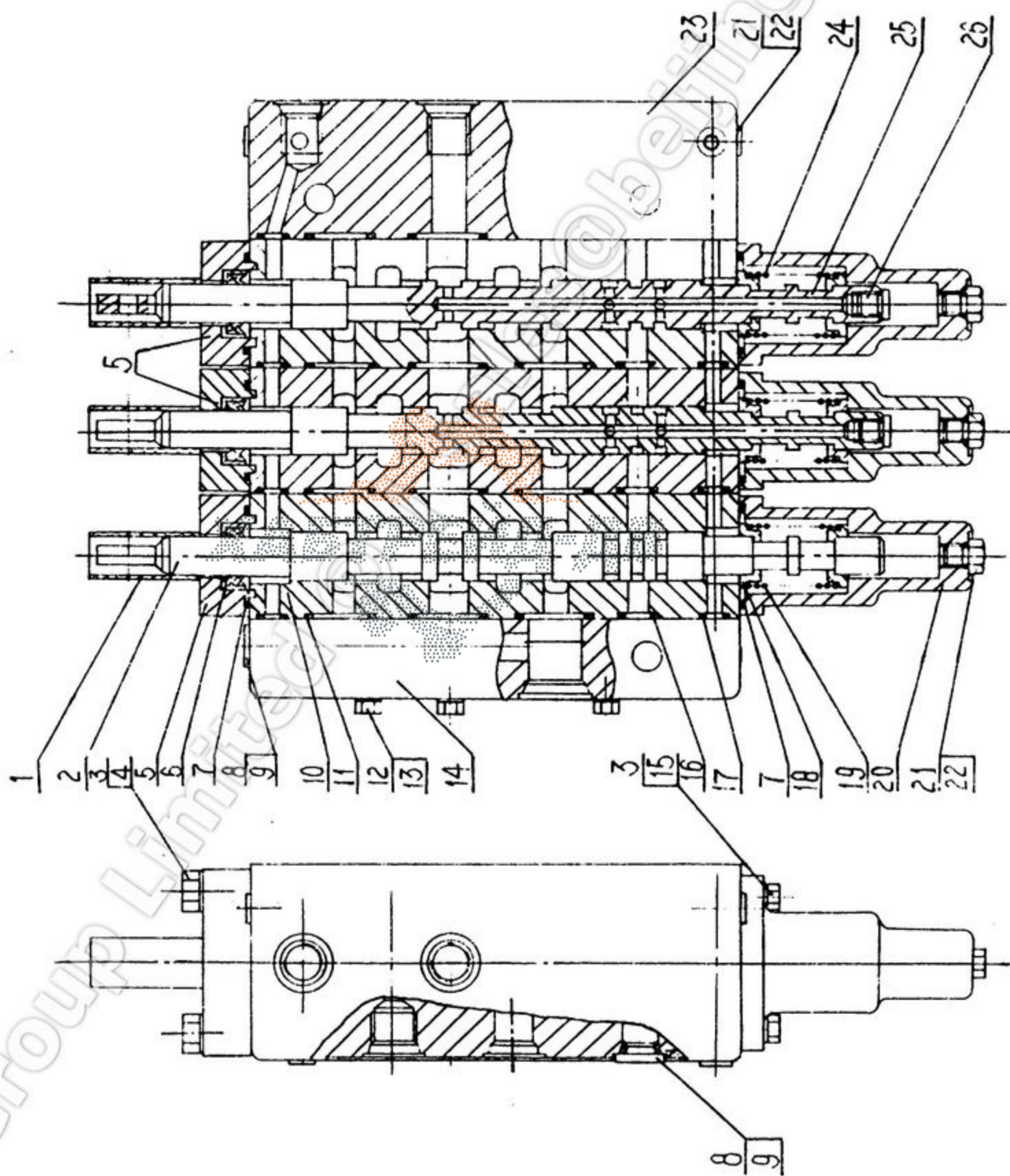

1T22000 多路液控换向阀 PILOT OPERATED VALVES

序号 NO.	代号 PART NO.	名 称 NAME	数量 Q'TY	备注 REMARK
1	1T22001	护套	3	
2	1T22002	侧倾阀杆	1	
3	1B03010	垫圈	12	
4	1B38326	螺栓	6	
5	1T22003	油封座	3	
6	1T22004	油封	3	
7	1T22005	O形圈	8	
8	1T22006	油塞	4	
9	1T22007	O形圈	4	
10	1T22008	阀体	3	
11	1T22009	O形圈	12	
12	1T22010	垫圈	3	
13	1T22011	螺栓	3	
14	1T22012	回油座	1	
15	1B03595	螺栓	6	
16	1T22013	O形圈	4	
17	1T22014	O形圈	8	
18	1T22015	弹簧座	6	
19	1T22016	侧倾回位弹簧	1	
20	1T22017	尾座	3	
21	1T22018	O形圈	7	
22	1T22019	油塞	7	
23	1T22020	进油座	1	
24	1T22021	松土回位弹簧	2	
25	1T22022	松土阀杆	2	
26	1T22023	锥堵	2	

8J7489—XG 多路换向先导阀(外配套件)
PILOT VALVE(PURCHASED PARTS)

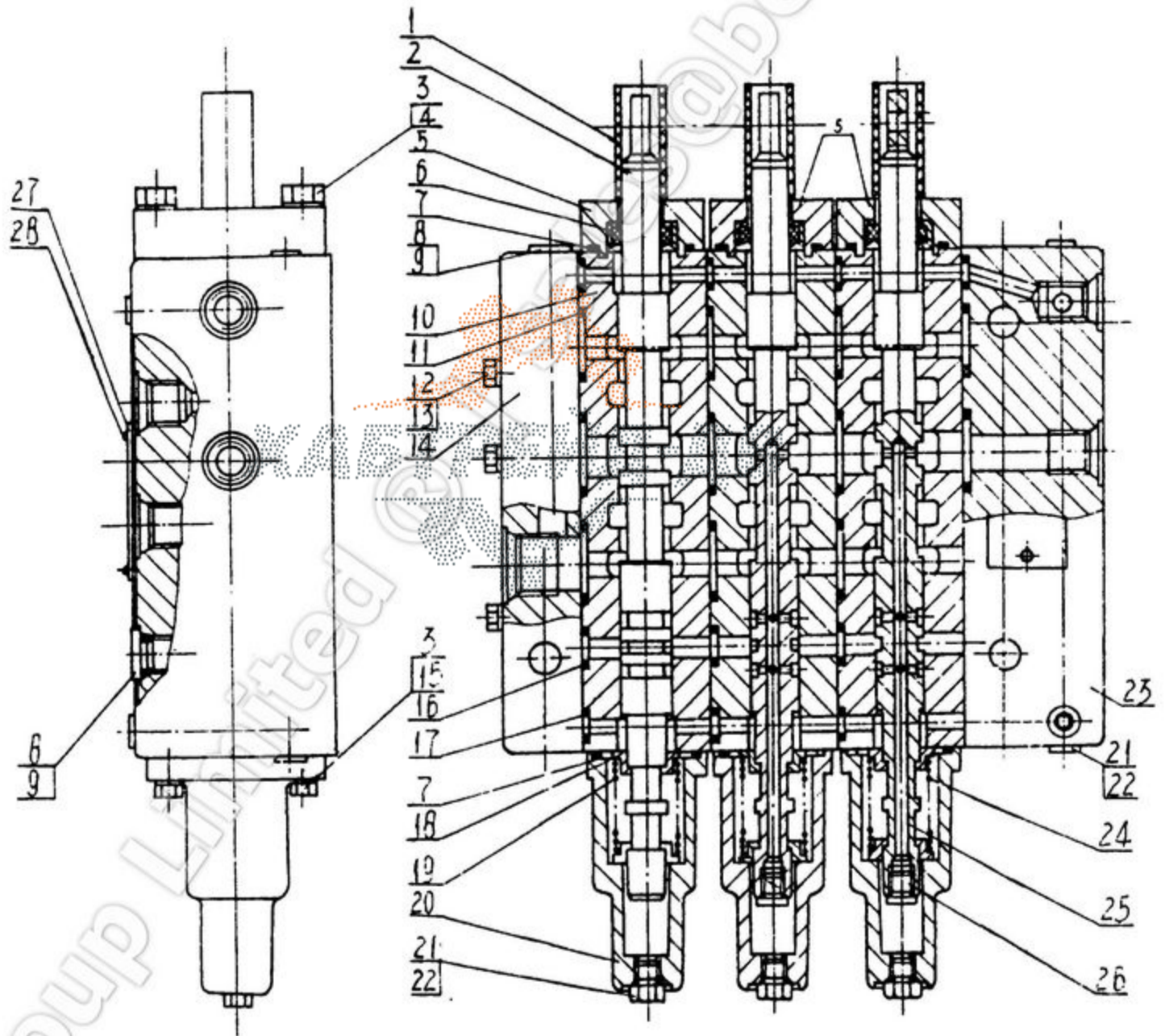

8J7489—XG 多路换向先导阀(外配套件)

PILOT VALVE(PURCHASED PARTS)

序号 NO.	代号 PART NO.	名 称 NAME	数量 Q'TY	备注 REMARK
1	3G730	管	3	
2	8J7491	倾斜阀芯	1	
3	5P0537	垫圈	12	
4	0S1616	六角头螺栓	6	
5	9J8714	压盖	3	
6	6V1949	骨架式橡胶油封	3	
7	8T9457	O形密封圈	6	
8	9S8002	螺塞	4	
9	3J7354	O型密封圈	4	
10	8J7490	阀体	3	
11	8T8978	O型密封圈	12	
12	GB93—76	弹簧垫圈 8	3	
13	3H3243—XG	螺栓	3	
14	8J7498	出口复式接头	1	
15	0S1615	六角头螺栓	6	
16	6J3134	O型密封圈	4	
17	8J1699	O型密封圈	8	
18	7J7844	定位环	6	
19	9J4800	倾斜阀芯弹簧	1	
20	9J4772	端盖	3	
21	4J7533	O型密封圈	7	
22	9S8001	螺塞	7	
23	8J7497	入口复式接头	1	
24	1U3243	松土阀芯弹簧	2	
25	8J7496	松土阀芯	2	
26	YE761-72	螺堵 Z $\frac{1}{16}$ "	2	
27	920601	标牌	1	
28	GB827-86	标牌用钉 2×4	1	

1T23000 左推土油缸总成
LEFT BULLDOZER CYLINDER ASSEM.

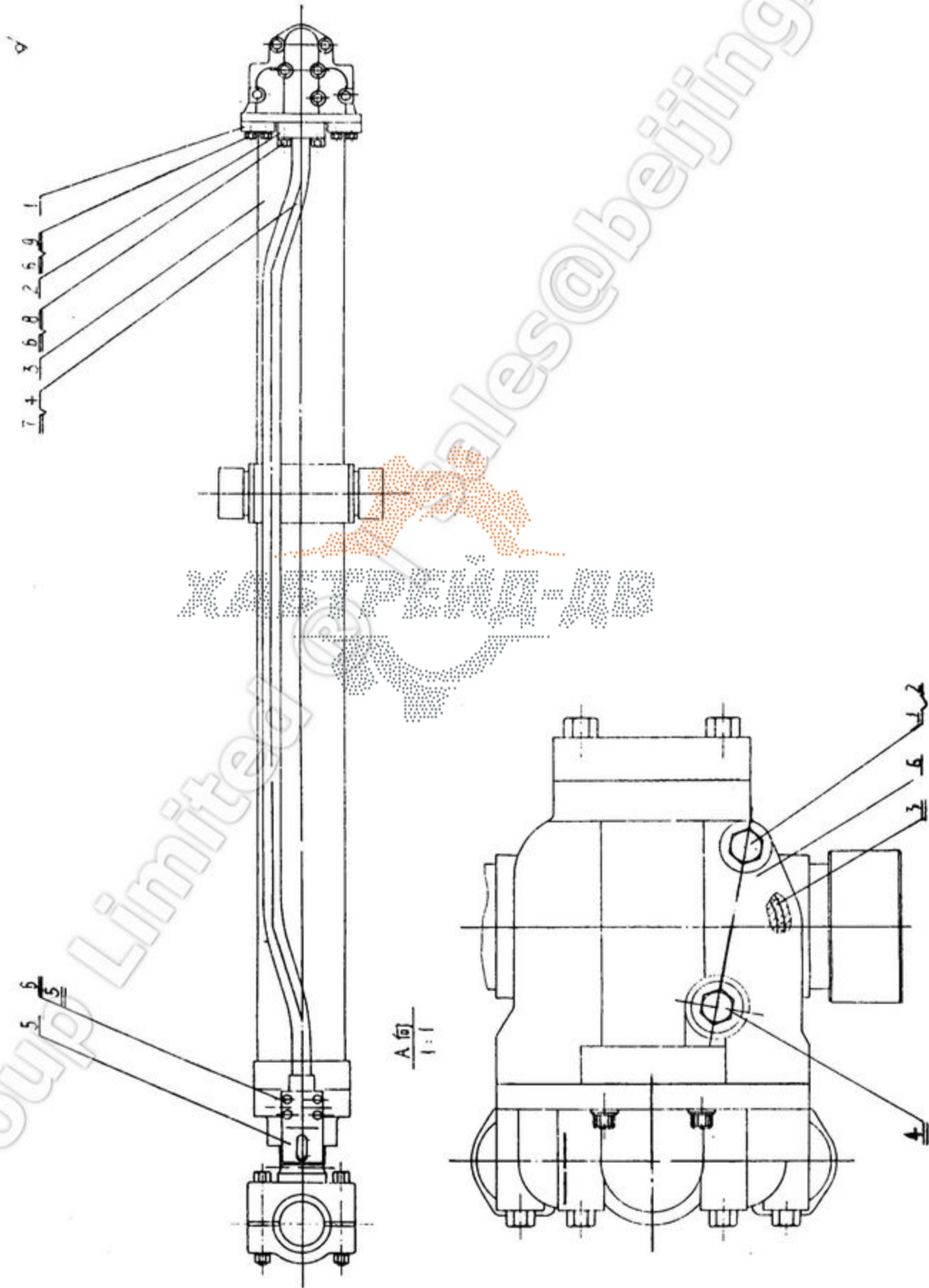

1T23000 左推土油缸总成
LIFT BULLDOZER CYLINDER ASSEM.

序号 NO.	代 号 PART NO.	名 称 NAME	数量 Q' TY	备注 REMARK
1	0T13027	油缸压盖	4	
2	0T13278	压盖	2	
3	1T23005	提升油缸	1	
4	1T23001	左油缸硬管	1	
5	0T13216	固定板	1	
6	1T23003	快降阀	1	
1	GB5782—86	螺栓 M16×100	1	
2	GB93—87	垫圈 16	2	
3	GB3452. 1-82	O 型圈 53×3. 55	1	
4	GB5782—86	螺栓 M16×140	1	
5	GB5782—86	螺栓 M10×80	4	
6	GB97. 1—86	垫圈 10	16	
7	GB3452. 2-82	O 形圈 36. 5×3. 55	2	
8	GB5782—86	螺栓 M10×35	4	
9	GB5782—86	螺栓 M10×30	8	

1T23003

快降阀

QUICK-DROP VALVE

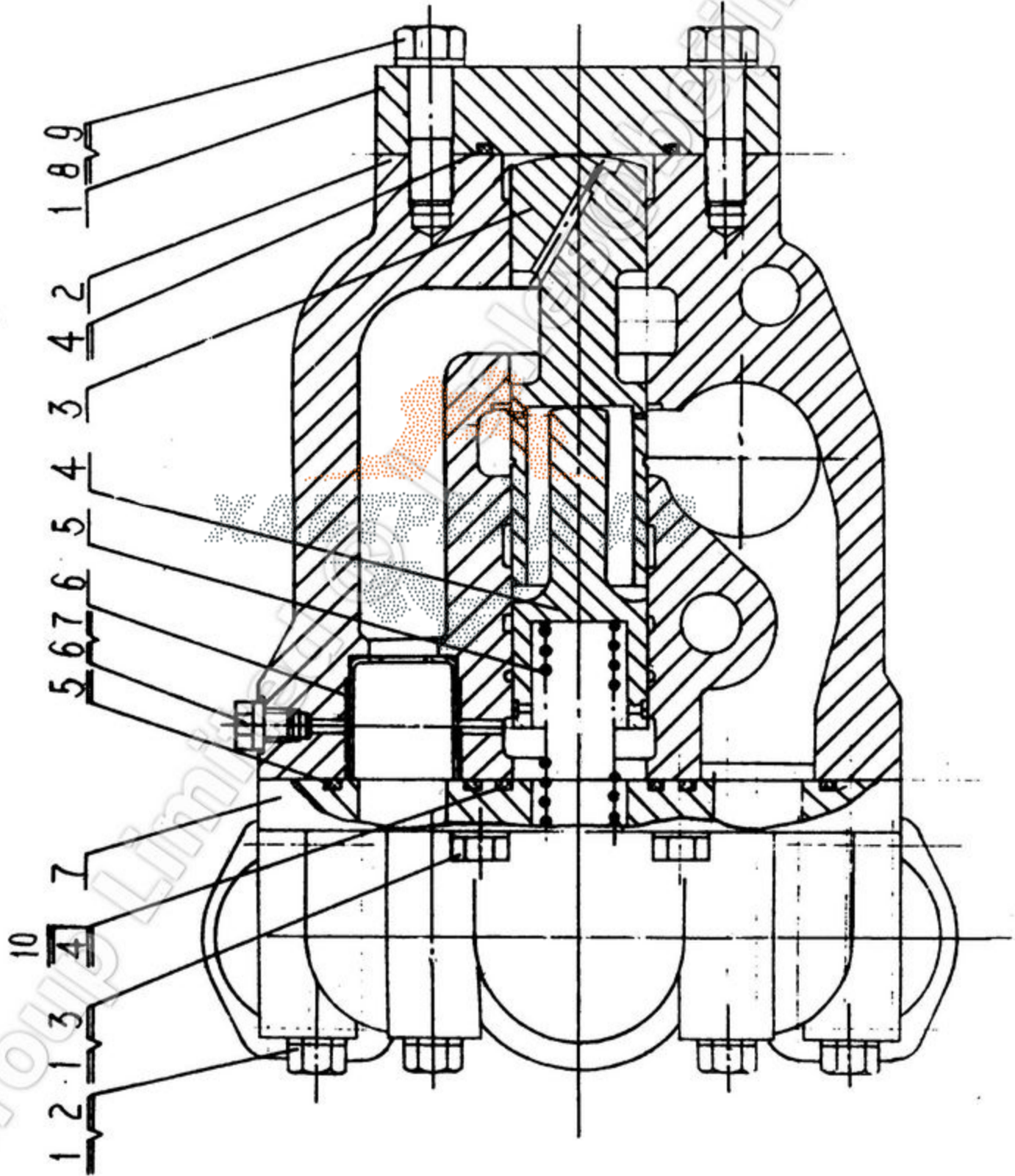

1T23003 快 降 阀 QUICK—DROP VALVE

序号 NO.	代 号 PART NO.	名 称 NAME	数量 Q' TY	备注 REMARK
1	0T13019	法兰盘	1	
2	0T13020	阀体	1	
3	0T13022	下阀芯	1	
4	0T13024	上阀芯	1	
5	0T13026	弹簧	1	
6	1T23004	节流套	1	
7	0T13018	法兰体	1	
1	GB97.1—85	垫圈 10	7	
2	GB5782—86	螺栓 M10×90	5	
3	GB5782—86	螺栓 M10×40	2	
4	GB3452.1-82	O 形圈 50×3.55	2	
5	GB3452.1-82	O 形圈 36.5×3.55	2	
6	JB1000—77	螺塞 M10×1	1	
7	JB982—77	垫圈 10	1	
8	GB93—87	垫圈 12	4	
9	GB5782—86	螺栓 M12×45	4	
10	GB3452.1-82	O 形圈 42.5×3.55	1	

1T23005 提升油缸 LIFT CYLINDER

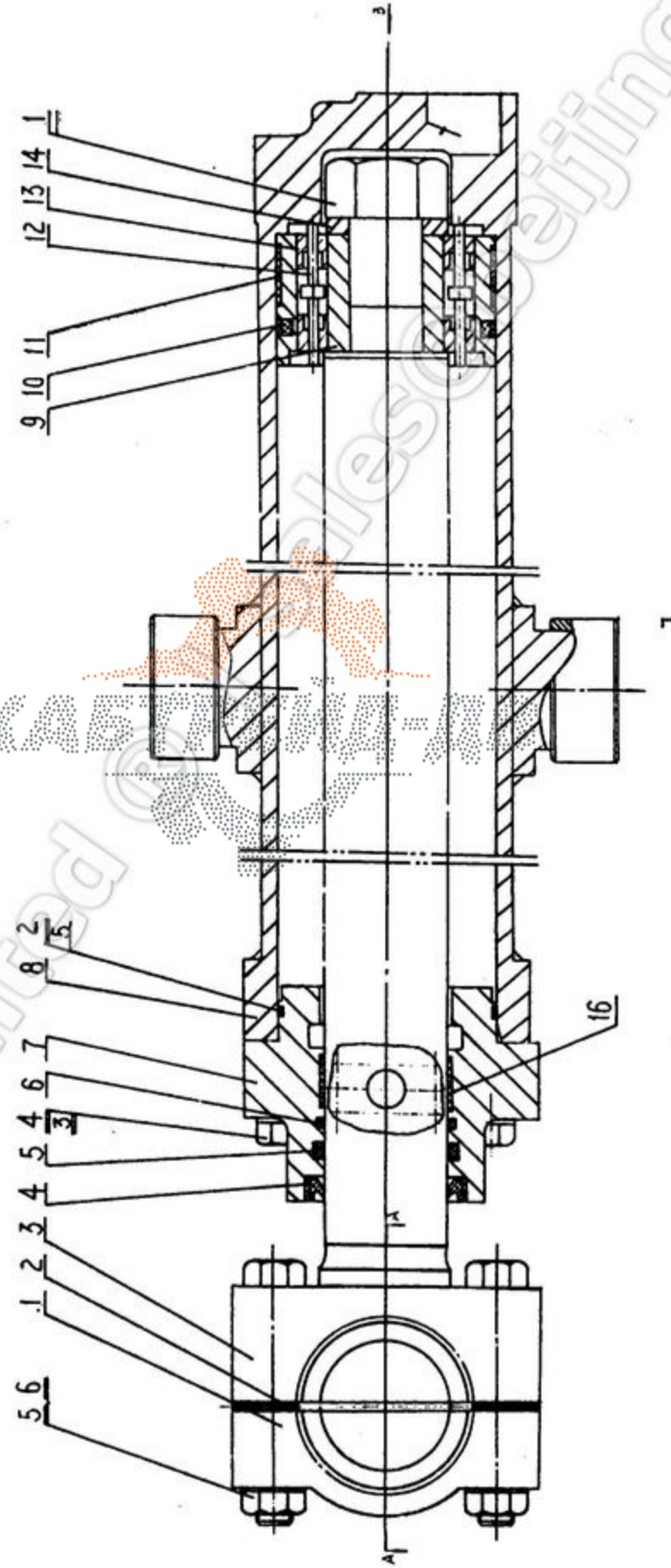

1T23005 提升油缸 LIFT CYLINDER

序号 NO.	代 号 PART NO.	名 称 NAME	数量 Q' TY	备注 REMARK
1	1T23006	半瓦	1	
2	1T23007	垫片	4	
3	1T23016	活塞杆组件	1	
4	1T23019	防尘组件	1	
5	1T23008	Y形密封圈	1	
6	1T23009	矩形密封圈	1	
7	1T23010	缸头	1	
8	1T23022	缸筒组件	1	
9	1T23011	活塞	1	
10	1T23026	密封组件	1	
11	1T23012	衬环	1	
12	0A33018	缓冲阀杆	2	
13	0A33019	阀套	4	
14	1T23013	垫圈	1	
15	1T23014	挡圈	1	
16	1T23015	支承环	1	
1	GB5785—86	螺栓 M48×3—200	1	
2	GB3452.1-82	O形圈 122×3.55	1	
3	GB93—87	垫圈 22	4	
4	GB5782—86	螺栓 M22×80	4	
5	GB97.1—85	垫圈 22—180HV	4	
6	GB6176—86	螺母 M22	4	

HSG—E130×1485/75ZQ 提升油缸(外配套件)
LIFT CYLINDER (PURCHASED PARTS)

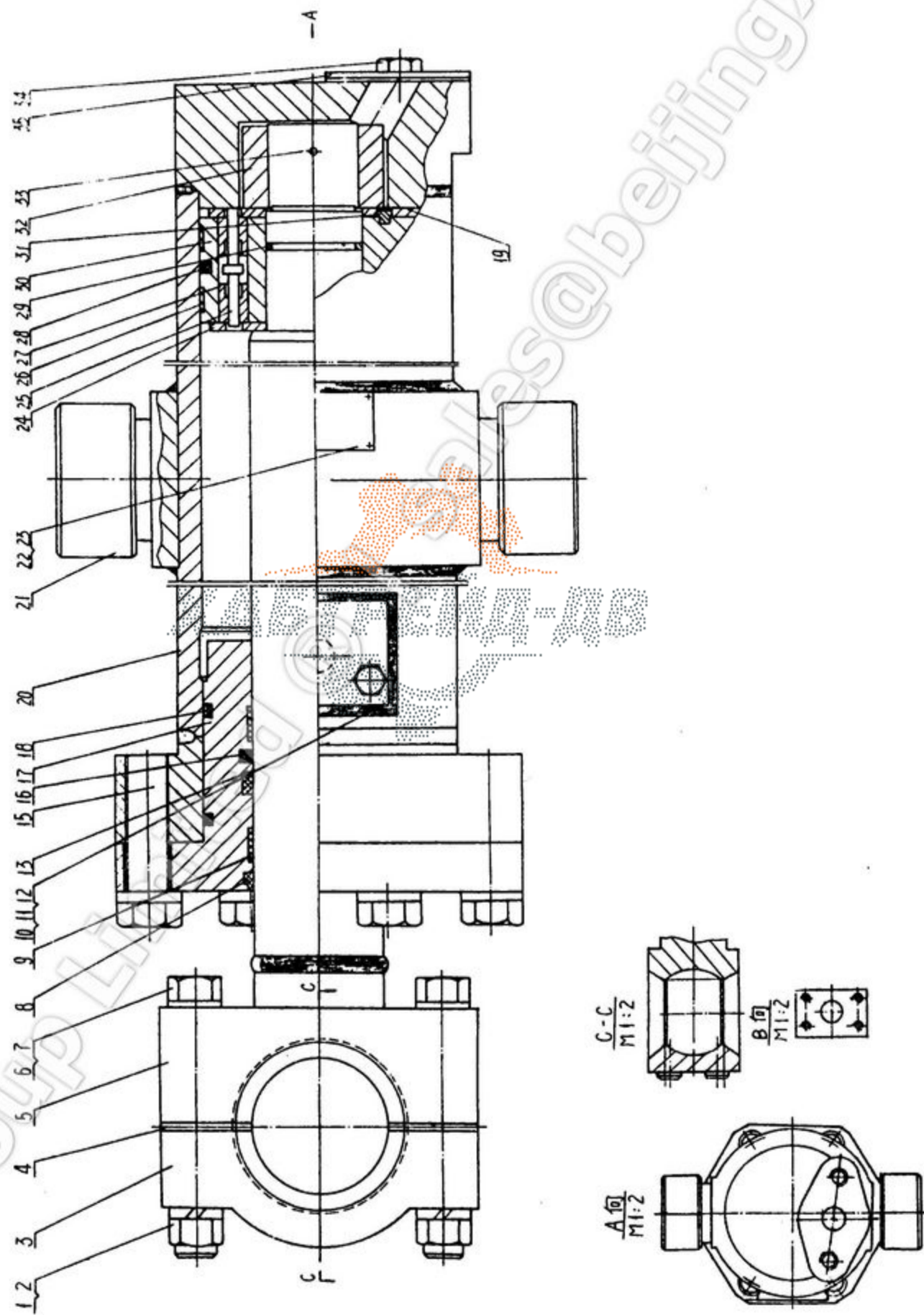

HSG—E130×1485/75ZQ 提升油缸(外配套件)

LIFT CYLINDER (PURCHASED PARTS)

序号 NO.	代号 PART NO.	名 称 NAME	数量 Q' TY	备 注 REMARK
1	GB6175—86	六角螺母 M24	NUT M24	4
2	GB93—87	弹簧垫圈 24	WASHER 24	10
3	XH06—1	轴承盖	FLANGE	1
4	XH06—2	垫片	WASHER	18
5	XH0601	活塞杆组件	PISTON ROD GROUP	1
6	GB97.2-85	平垫圈 24	WASHER 24	4
7	GB5782—86	六角头螺栓	BOLT	4
8	CK75	防尘圈 d75	DUST PROOF RING d75	1
9	XH06—3	导向环	GUIDE RING	2
10	XH01—5	护盖	COVER	1
11	XH01—6	护垫	GASKET	2
12	GB5781—86	螺栓 M10×20	BOLT M10×20	2
13	YXd75×87×14	YX 型轴向密封圈	YX—SEAL RING	1
15	GB5783—86	六角头螺栓	BOLT	4
16	ZYS75×6	轴用组合密封圈	SEAL RING GROUP	1
17	XH06—5	导向套	GUIDE SLEEVE	1
18	GB3452.1-82	O 型密封圈 53011800	O—SEALRING 53011800	2
19	XH06—6	挡盘	RETAINNING PLATE	1
20	XH0602	缸体组件	CYLINDER GROUP	1
21	XH06—7	轴套	SLEEVE	2
22	GB827—86	铆钉 3×3	RIVET 3×3	4
23	XH06—8	铭牌	LABEL	1
24	XH06—9	挡盘	RETAINNING PLATE	1
25	XH01—11	滑阀	SLIDE VALVE	2

HSG—E130×1485/75ZQ 提升油缸(外配套件)

LIFT CYLINDER (PURCHASED PARTS)

序号 NO.	代号 PART NO.	名称 NAME	数量 Q'TY	备注 REMARK
26	XH06—10	导向环 GUIDE RING	2	
27	XH01—12	阀套 SLEEVE	4	
28	CKW1300	孔用组合密封圈 SEAL RING GROUP	1	
29	GB3452.1-82	O型密封圈 35504870 O—SEAL RING 35504870	1	
30	XH06—11	活塞 PISTON	1	
31	XH01—18	销轴 PIN	2	
32	XH06—12	螺母 NUT	1	
33	GB91—86	开口销 $\varnothing 6 \times 75$ COTER PIN $\varnothing 6 \times 75$	1	
34	GB5781—86	螺栓 M16×35 BOLT M16×35	2	
35	XH01—16	护盖 COVER	1	

1T24000 右推土油缸总成
RIGHT BULLDOZER CYLINDER ASSEM.

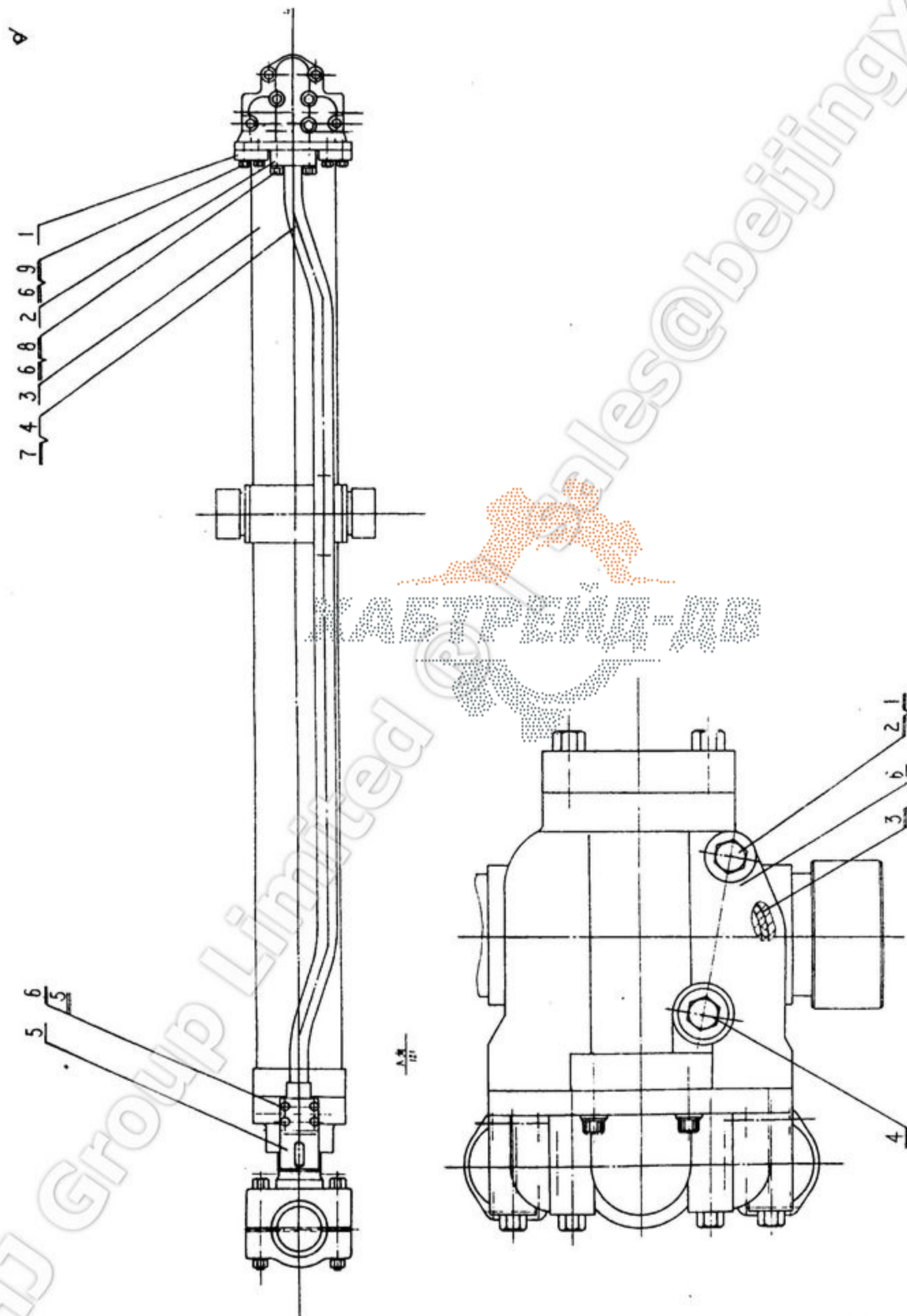

1T24000 右推土油缸总成
RIGHT BULLDOZER CYLINDER ASSEM.

序号 NO.	代 号 PART NO.	名 称 NAME	数量 Q' TY	备注 REMARK
1	0T13027	油缸压盖	4	
2	0T13278	压盖	2	
3	1T23005	提升油缸	1	
4	1T24001	右油缸硬管	1	
5	0T13216	固定板	1	
6	1T23003	快降阀	1	
1	GB5782—86	螺栓 M16×100	1	
2	GB97.1—85	垫圈 16	2	
3	GB3452.1-82	O形圈 53×3.55	1	
4	GB5782—86	螺栓 M16×140	1	
5	GB5782—86	螺栓 M10×80	4	
6	GB97.1—85	垫圈 10	16	
7	GB3452.1-82	O型圈 36.5×3.55	2	
8	GB5782—86	螺栓 M10×35	4	
9	GB5782—86	螺栓 M10×30	8	

1T25000 空调系统 CONDITIONOR SYSTEM

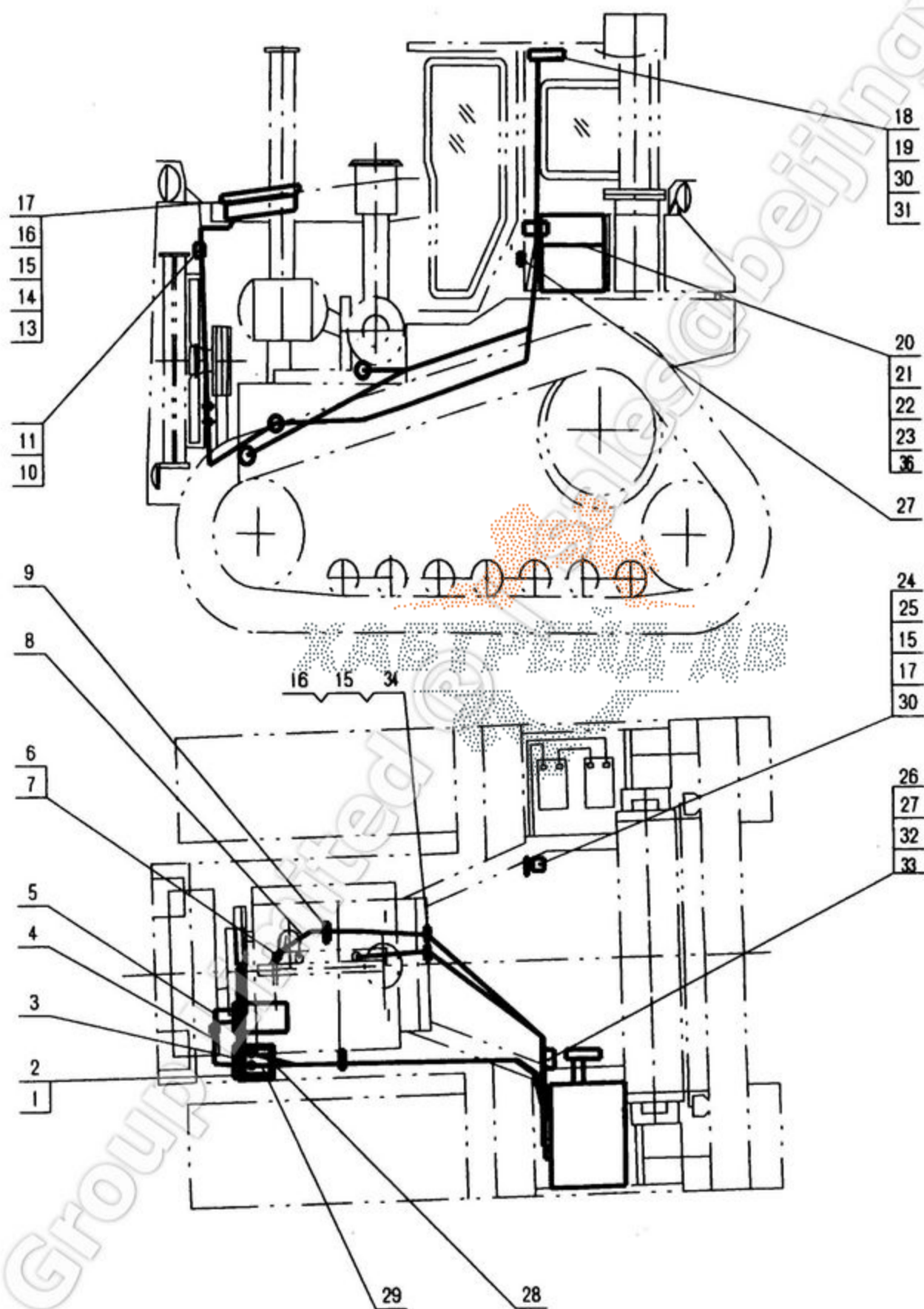

1T25000 空调系统 CONDITIONOR SYSTEM

序号 NO.	代 号 PART NO.	名 称 NAME	数量 Q' TY	备注 REMARK
1	1T25001	空调支架总成	1	
2	1T25007	压缩机 SD-7H15	1	
3	1T25008	V 型带 A1000	2	
4	1T25009	空调器软管(1)	1	
5	1T25010	空调器软管(2)	1	
6	1T25011	水管管接头	2	
7	1T25030	喉箍 0#	4	
8	1T25012	空调器水管	2	
9	1B01406	卡子	6	
10	GB5783-86	螺栓 M6×12	4	
11	1T25013	储液干燥器	1	
12	1T25014	冷凝器	1	
13	1T25015	冷凝器护罩	1	
14	GB5783-86	螺栓 M10×20	13	
15	GB97.1-86	垫圈 10-200HV	10	
16	GB93-87	垫圈 10	11	
17	1T25019	控制面板总成	1	
18	1T25020	支板总成	1	
19	1T25023	空调器蒸发器	1	
20	GB5783-86	螺栓 M12×20	5	
21	GB97.1-86	垫圈 12-200HV	5	
22	GB93-87	垫圈 12-200HV	5	
23	1T25024	右出风罩	1	
24	1T25025	风窗	1	
25	1T25026	左出风罩	1	

1T25000 空调系统 CONDITIONOR SYSTEM

序号 NO.	代 号 PART NO.	名 称 NAME	数量 Q' TY	备注 REMARK
26	1T25027	风窗 VENT WINDOW	3	
27	1T25028	空调器软管(3) HOSE(3)	1	
28	1T25029	空调器软管(4) HOSE(4)	1	
29	GB5783-86	螺栓 M5×10 BOLT	8	
30	GB5783-86	螺栓 M8×16 BOLT	4	
31	GB70-85	螺钉 M8×16 SCREW	1	
32	1B22088	夹子 CLIP	6	
33	1T25031	制冷剂 COOLANT	1	
34	1T25032	垫 SHIM	1	

1T26000 牵引机构 DRAWING MECHANISM

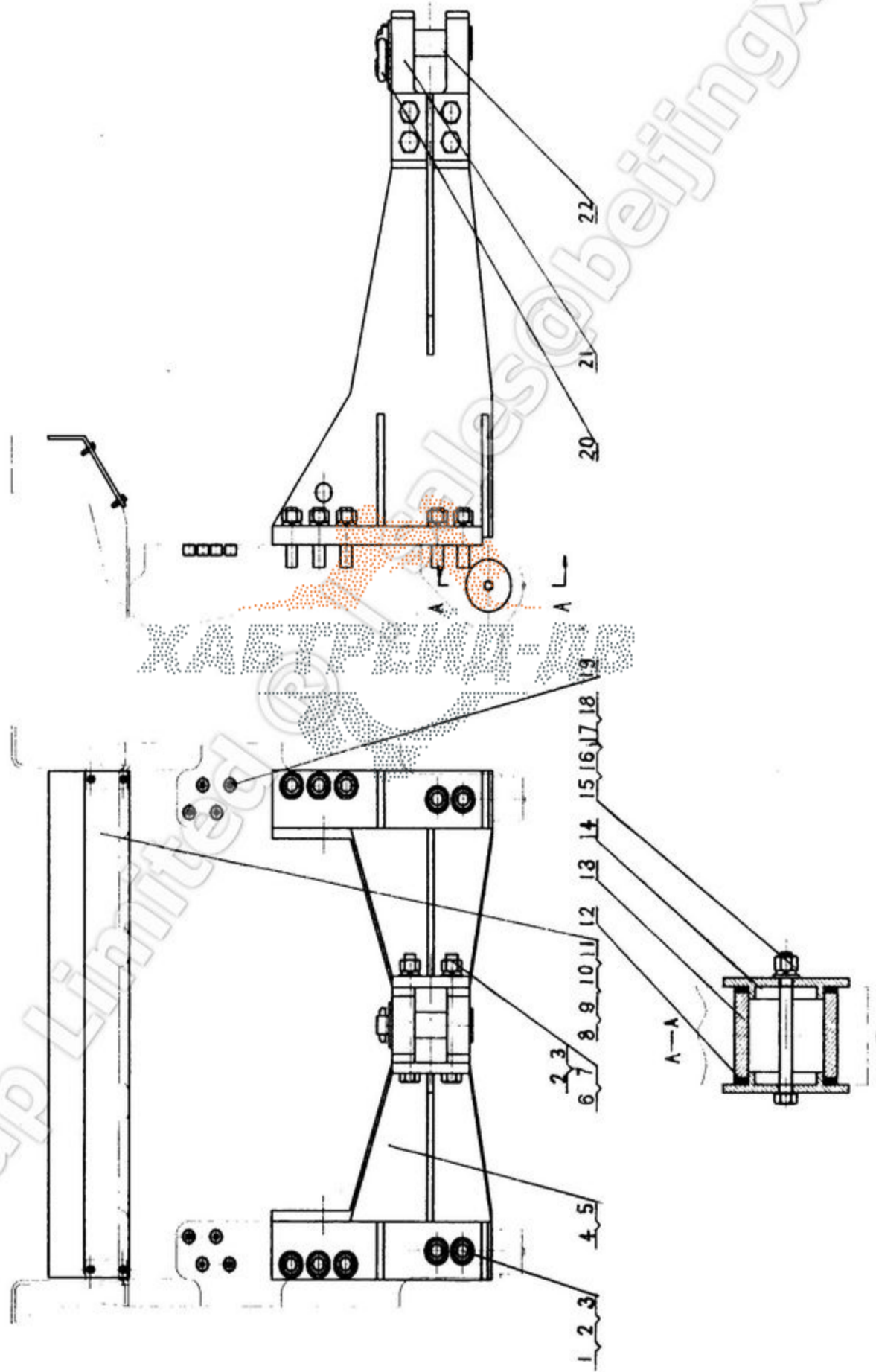

1T26000 牵引机构 DRAWING MECHANISM

序号 NO.	代 号 PART NO.	名 称 NAME	数量 Q' TY	备注 REMARK
1	GB898-88	螺柱 AM36×95-8.8	8	
2	GB6170-86	螺母 36	12	
3	GB93-87	垫圈 36	12	
4	1T26001	左牵引板	1	
5	1T26006	右牵引板	1	
6	GB5782-86	螺栓 M36×320-10.9	4	
7	GB97.1-85	垫圈 36	4	
8	1T26012	板	1	
9	GB5783-86	螺栓 M12×30	4	
10	GB97.1-85	垫圈 12	4	
11	GB93-87	垫圈 12	4	
12	JB/ZQ3788 -86	密封圈 C-1-95	4	
13	1T20070	轴套	2	
14	1T26014	堵盖	4	
15	GB5782-86	螺栓 M16×165	2	
16	GB93-87	垫圈 16	2	
17	GB97.1-85	垫圈 16	2	
18	GB6170-86	螺母 M16	2	
19	1T26013	堵	8	
20	0A30003	拉环	1	
21	1T26009	拉杆座	1	
22	1T26011	拉杆销	1	