

目 录

CONTENTS

1. 发动机及关联部件 Engine Related Parts

发动机附件及安装 -----101

Engine assembly

操纵系统 -----102

Control system

分动箱装配 -----103

Wheel box assembly

2. 传动及操纵部件 Drive and control assembly

传动系统 -----201

Transmission system

驱动桥 -----202

Drive bridge

制动器 -----203

Brake

主减速器-----204

Main speed reducer

手刹车装置 -----205

Hand brake

三速变速箱总成 -----206

Three-speed gear box

手刹车及变速操纵系统-----207

Hand brake and speed-control

脚刹车总成-----208

Foot brake

后轮总成-----209

Wheels Assembly

3. 主机架及工作装置 Main Frame and work equipment

前机架总成 (SR12、YZ12B)-----301

Drum Frame assembly

前机架总成 (SR12P、YZK12B)-----302

Drum Frame assembly

振动轮总成(1/2) ----- 303

Drum assembly

振动轮总成(2/2) ----- 304

Drum assembly

凸块轮 (SR12P、YZK12B)----- 305

Pad feet drum assembly

铰接总成-----306

Articulate Device Assembly	
后机架总成 -----	307
Rear frame assembly	
左踏板 -----	308
Left ladder	
右踏板 -----	309
Right ladder	
4. 防护装置 Guard equipment	
地板架总成 -----	401
Platform assembly	
驾驶室 -----	402
Cab assembly	
后机罩总成 -----	403
Engine hood assembly	
司机座 -----	404
Seat	
5. 液压系统 Hydraulic system	
液压油箱及安装 -----	501
Gasoline tank assembly	
行走液压系统-----	502
Hy-propulsion system	
振动液压系统-----	503
Hydraulic vibratory system	
转向液压系统-----	504
Hydraulic steering system	
连杆装配 -----	505
Link assembly	
转向油缸总成 (1/2) -----	506
Steering cylinder assembly	
转向油缸总成 (2/2) -----	507
Steering cylinder assembly	
6. 电气系统 Electrical	
电器系统 -----	601
Electrical System	
仪表柜总成 -----	602
Instrument case	
仪表盘总成 -----	603
Instrument box	
制冷系统(选装件)-----	604
Cool system (options)	

使用说明

本册零件目录供用户选购我厂生产的标准型或空调型 SR12、SR12P、YZ12B、YZK12B 振动压路机时参考使用。

本目录以压路机为主要叙述对象，对于各种配套件，如：发动机、液压油泵、液压马达、操纵阀、液压转向器等，见各配套厂家的说明书或零件目录。

本零件目录所包含的内容均为该机可更换的零部件，用户可以采购其中任何一种零部件。

采购零部件时，为避免发生错误，请务必注明以下各项详细资料：

- 1、 压路机的出厂编号。
- 2、 压路机的出厂日期。
- 3、 所采购的零部件的序号、代号、名称。
- 4、 所需数量。

另外，产品资料会因产品的不断改进而有所变更。采购时请向销售人员详细咨询，以便获得准确信息。

山推工程机械股份有限公司道路机械分公司

Instruction

This catalogue is only preferred for ordering of type SR12,SR12P,YZ12B,YZK12B and air-conditional vibratory roller.

It describes mainly the composition of the rollers. For more and detailed information regarding purchase components, such as engine、hydraulic pump、hydraulic motor、control valve and steering unit, please look the relevant instruction or spare parts catalogue from the sub-supplier accordingly.

All the contents of this parts catalog are exchangeable options, the user can order anyone of them.

To avoid wrong delivery, please clarify the following points correctly when you order:

1. Serial number of the roller.
2. Manufacture date.
3. Give clear indication of No., item number, name of the parts.
4. Quantity.

In addition, Our product' s information at any moment change by reason of our development. If it differ from this book., please contact with our sell-man, gain the correct and detailed information.

SHANTUI CONSTRUCTION MACHINERY CO., LTD

液压系统

HYDRAULIC SYSTEM



第 501 图 液压油箱及安装

FIG.501 GASOLINE TANK ASSEMBLY

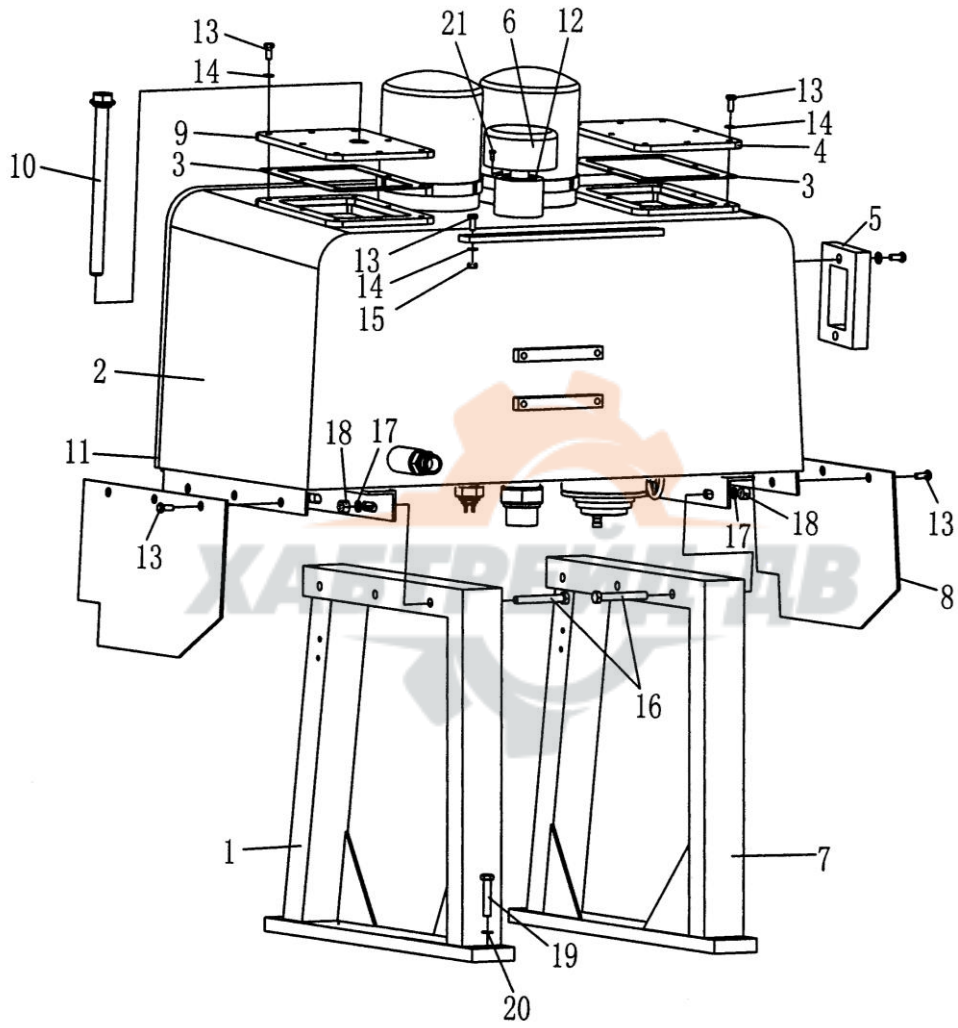

液压油箱及安装

GASOLINE TANK ASSEMBLY

序号 Index NO.	代 号 Par NO.	名 称 Name	数量 Q'ty
1	12ZB-14-01000	支架(1) Bracket	1
2	12ZB-14-02000	箱体 Gasoline tank	1
3	12ZB-14-00001	密封垫 Gasket	2
4	12ZB-14-00002	盖板(1) Cover	1
5	12ZB-14-03000	油位计 Gauge	1
6	12ZB-14-04000	空滤器 Aeration filter	1
7	12ZB-14-05000	支架(2) Bracket	1
8	12ZB-14-00003	板 Plate	2
9	12ZB-14-00004	盖板(2) Cover	1
10	16Z-05-50000	磁棒 Magnetic core	1
11	12ZB-15-00001	密封条 Gasket	1
12	12ZB-14-00005	密封垫 Gasket	1
13	01010-50820	螺栓 M8*20 Bolt	25
14	01643-30823	垫圈 8 Washer	16
15	01580-00806	螺母 M8 Nut	3
16	01010-51280	螺栓 M12*80 Bolt	6
17	01643-31232	垫圈 12 Washer	6
18	01580-01210	螺母 M12 Nut	6
19	01010-51260	螺栓 M12*60 Bolt	8
20	01235-40516	十字槽盘头螺钉 M5*16 Screw	4

第 502 图 行走液压系统

FIG.502 HYDRAULIC PROPULSION SYSTEM

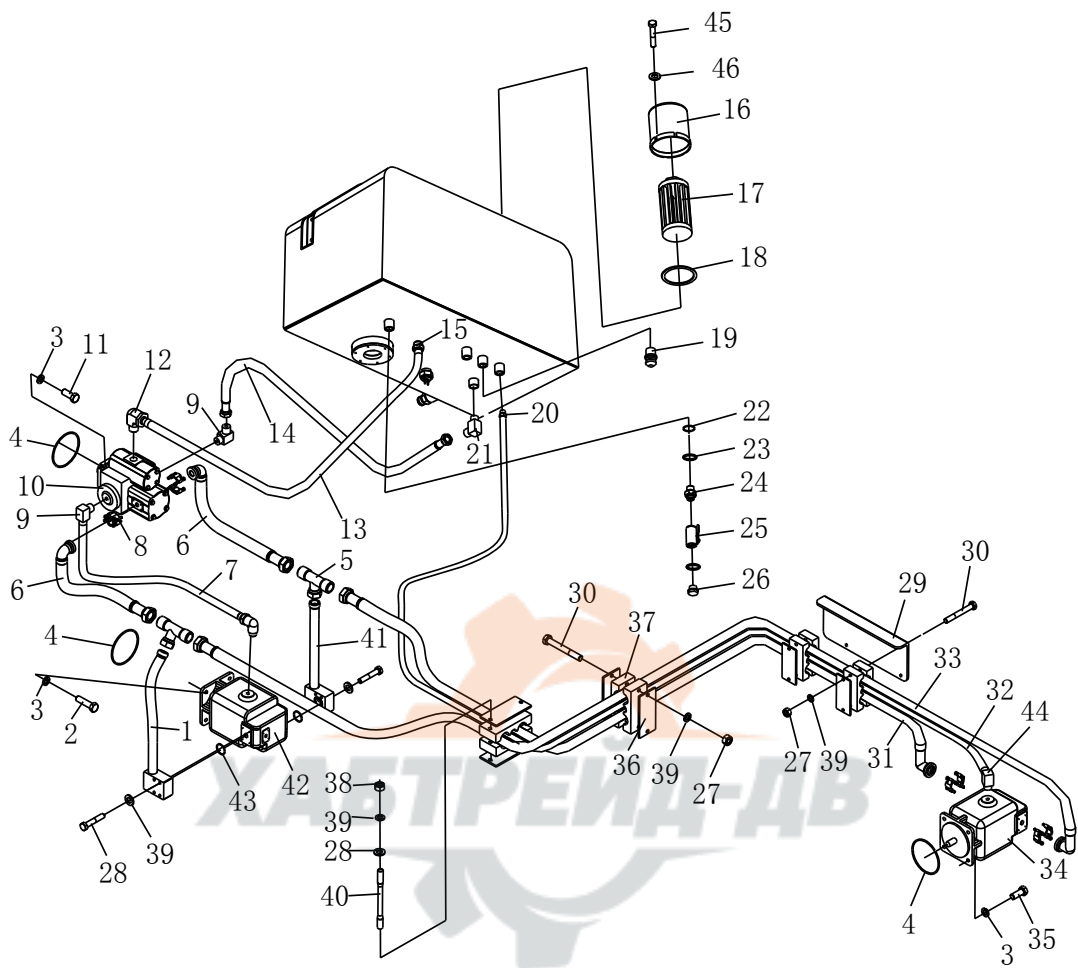

行走液压系统

HYDRAULIC PROPULSION SYSTEM

序号 Index NO.	代 号 Par NO.	名 称 Name	数量 Q'ty
1	12ZB-05-14000C	管 Hose	1
2	01010-51245	螺栓 Bolt	4
3	01643-31232	垫圈 Washer	12
4	07000-12125	O 型圈 O-ring	3
5	12ZB-05-21000A	接头 BD-36 Adapter	2
6	12ZB-05-01000B	软管总成 Hose	1
7	12ZB-05-18000A	软管总成 Hose	1
8	12ZB-05-15000A	分离法兰组件 FL-16 Half-flange	4
9	12ZB-05-05000A	接头 1CO9-30-12OG Adapter	3
10	12ZB-05-01000	行走泵 Pump	1
11	01010-51230	螺栓 Bolt	4
12	12ZB-05-00002A	接头 1CO9-36-16 Adapter	1
13	12ZB-05-10000A	软管总成 Hose	1
14	12ZB-05-19000A	软管总成 Hose	1
15	12ZB-05-17000A	接头 1CH-36-27 Adapter	1
16	12ZB-12-01000	滤罩 Cover	1
17	12ZB-12-02000	滤油器 Filter	1
18	07000-12120	O型圈 O-ring	1
19	12ZB-05-00006	液压油温发送器 sender	1
20	12ZB-05-16000A	接头 1CH-30-12OG Adapter	1
21	12ZB-05-00001A	接头 1CH9-30-27OG Adapter	1
22	07002-12434	O型圈 O-ring	1
23	12ZB-05-00005	垫圈 Washer	2
24	12ZB-05-00009	接头 Adapter	1
25	12ZB-05-09000	球阀 BKH-G3/4-1923 Valve	1
26	12ZB-05-00008	螺塞 Plug	1
27	01580-11008	螺母 Nut	6
28	02010-20657	螺栓 Bolt	8
29	16Z-14-00016	板 Plate	1
30	01010-51080	螺栓 Bolt	6

行走液压系统

HYDRAULIC PROPULSION SYSTEM

序号 Index NO.	代 号 Par NO.	名 称 Name	数量 Q'ty
31	12ZB-05-02000B	软管总成 Hose	1
32	12ZB-05-02000A	软管总成 Hose	1
33	12ZB-05-03000B	软管总成 Hose	1
34	12ZB-05-06000	前驱马达 Hydraulic motor	1
35	02010-20838	螺栓 Bolt	4
36	12ZB-05-00003	板 Plate	2
37	12ZB-05-00004	板 Plate	8
38	01582-11008	螺母 Nut	2
39	01643-31032	垫圈 Washer	18
40	01160-31075	双头螺柱 Bolt	2
41	12ZB-05-13000C	管 Hose	1
42	12ZB-05-07000	后驱马达 Hydraulic motor	1
43	07000-13032	O 型圈 O-ring	2
44	12ZB-05-20000A	接头 1C0-30-12 Adapter	1
45	01010-50825	螺栓 M8*25 Bolt	6
46	01643-30823	垫圈 washer	6

FIG.503 HYDRAULIC VIBRATORY SYSTEM

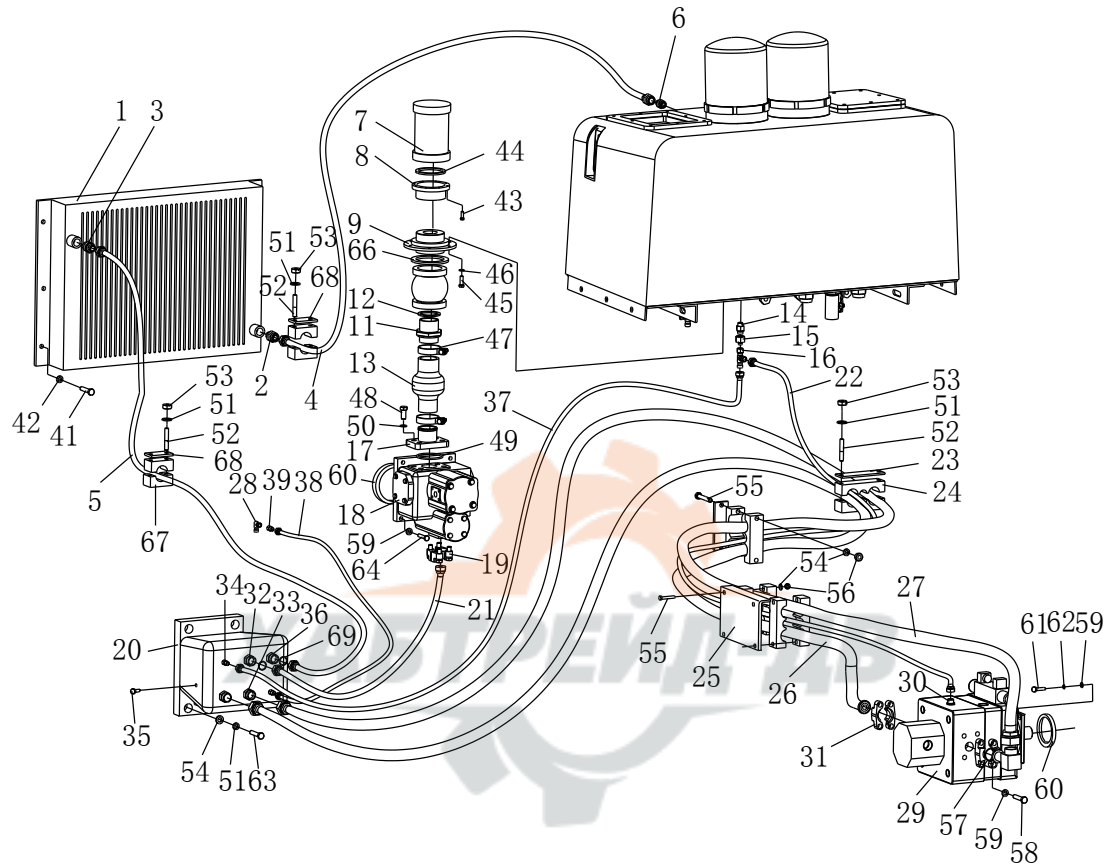

振动液压系统

HYDRAULIC VIBRATORY SYSTEM

序号 Index NO.	代 号 Par NO.	名 称 Name	数量 Q'ty
1	12ZB-10-01000A	油冷器 Oil cooler	1
2	12ZB-10-00010B	接头 1CH-36-33 Adapter	1
3	12ZB-10-17000B	接头 1CH9-36-33OG Adapter	1
4	12ZB-10-02000B	软管总成 Hose	1
5	12ZB-10-03000B	软管总成 Hose	1
6	12ZB-05-17000A	接头 1CH-36-27 Adapter	1
7	12ZB-10-04000	滤油器 Filter	1
8	16Z-13-00003	法兰 Flange	1
9	12ZB-10-06000	法兰 Flange	1
11	12ZB-10-08000	接头 Adapter	1
12	12ZB-10-00007	垫圈 Washer	2
13	12ZB-10-00001	鼓形管 Banjo	1
14	12ZB-10-09001A	接头 1CH-22 Adapter	1
15	12ZB-10-09002A	接头 2C-14-22 Adapter	1
16	12ZB-10-09003A	接头 CC-14 Adapter	1
17	12ZB-10-00003	法兰 Flange	1
18	12ZB-10-10000	双联泵 Double pump	1
19	12ZB-05-15000A	分离法兰组件 FL-16 Half flange	1
20	12ZB-10-11000	振动阀 Valve	1
21	12ZB-10-12000A	软管总成 Hose	1
22	12ZB-10-20000B	软管总成 Hose	1
23	12ZB-05-00003	板 Plate	2
24	12ZB-10-00002	板 Plate	8
25	16Z-13-00011	板 Plate	1
26	12ZB-10-21000B	软管总成 Hose	1
27	12ZB-10-22000B	软管总成 Hose	1
28	12ZB-10-25000A	接头 2C9-14 Adapter	1
29	12ZB-10-13000	振动马达 Hydraulic motor	1
30	12ZB-10-00004A	接头 1CT-14-04SP Adapter	1
31	12ZB-10-00015B	分离法兰 FL-20 Half flange	4

振动液压系统

HYDRAULIC VIBRATORY SYSTEM

序号 Index NO.	代 号 Par NO.	名 称 Name	数量 Q'ty
32	12ZB-10-00012A	接头 Adapter	2
33	12ZB-10-00005A	接头 1CH-36-30×1.5 Adapter	2
34	12ZB-10-00006A	接头 1CH-12-10 Adapter	2
35	CSH M10*1	堵塞 Plug	1
36	12ZB-10-14000A	接头 2C9-36 Adapter	1
37	12ZB-10-23000A	软管总成 Hose	1
38	12ZB-10-24000A	软管总成 Hose	1
39	12ZB-10-15000A	接头 1CO9-12-04OG Adapter	1
41	01010-30820	螺栓 Bolt	6
42	01643-50823	垫圈 Washer	6
43	01016-50616	螺栓 Bolt	4
44	07000-12082	O 型圈 O-ring	1
45	01010-50620	螺栓 Bolt	6
46	01643-20623	垫圈 Washer	6
47	07281-00509	喉箍 3×51-70 Hose clamp	2
48	02010-20832	螺栓 Bolt	4
49	07000-13050	O 型圈 O-ring	1
50	01643-31445	垫圈 Washer	4
51	01643-51032	垫圈 Washer	10
52	01160-31075	双头螺柱 Bolt	6
53	01582-11008	螺母 Nut	6
54	01643-31032	垫圈 Washer	16
55	01010-51080	螺栓 Bolt	6
56	01580-11008	螺母 Nut	6
57	07000-13040	O 型圈 O-ring	2
58	02010-20744	螺栓 Bolt	8
59	01643-31232	垫圈 Washer	16
60	07000-12125	O 型圈 O-ring	2
61	01010-51240	螺栓 Bolt	4
62	01643-31232	垫圈 Washer	4

振动液压系统

HYDRAULIC VIBRATORY SYSTEM

序号 Index NO.	代 号 Par NO.	名 称 Name	数量 Q'ty
63	01010-51035	螺栓 Bolt	4
64	01010-51235	螺栓 Bolt	4
66	07000-12120	O 型圈 O-ring	1
67	12ZB-10-00016	管夹 Clamp	4
68	12ZB-10-00017	板 Plate	2
69	07000-13034	O 型圈 O-ring	2



第 504 图 转向液压系统

FIG.504 STEERING CYLINDER ASSEMBLY

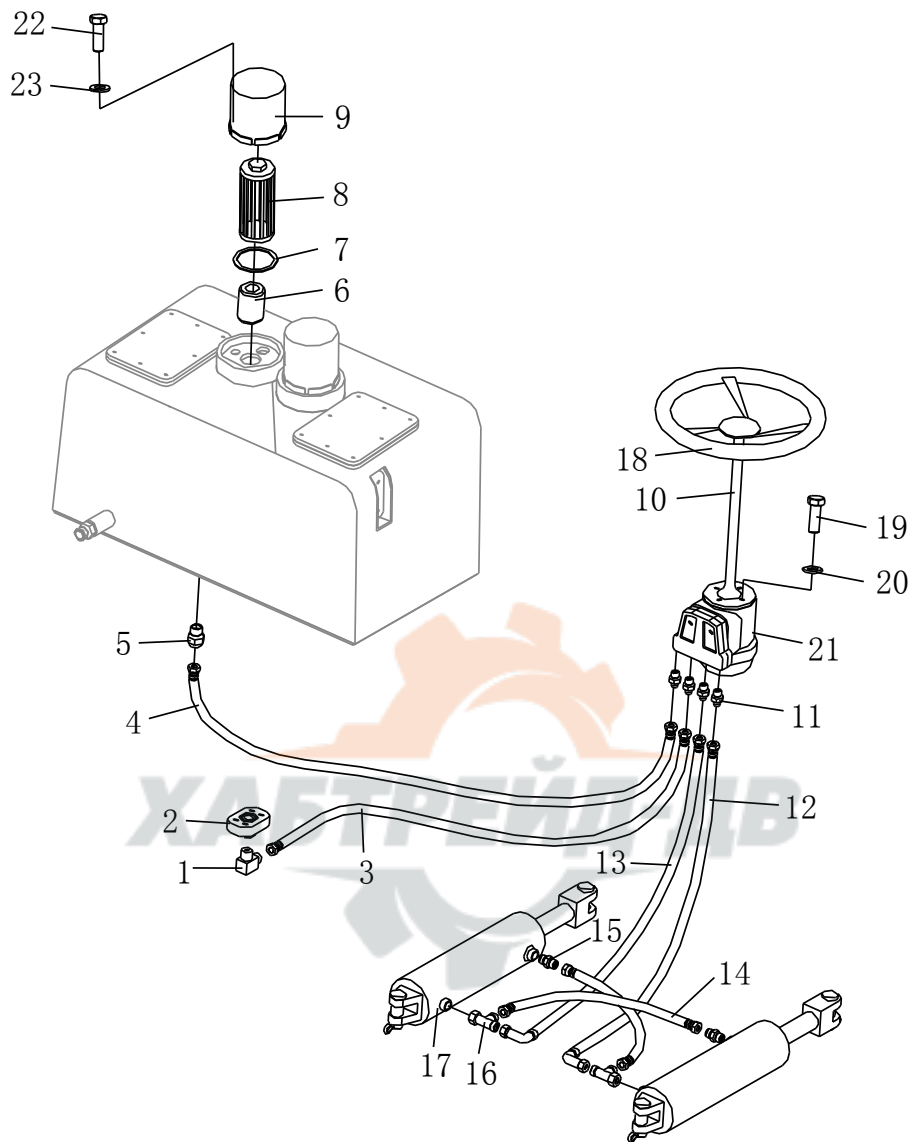

转向液压系统

STEERING CYLINDER ASSEMBLY

序号 Index NO.	代 号 Par NO.	名 称 Name	数量 Q'ty
1	12ZB-12-00001A	接头 1CFL9-26-12 Adapter	1
2	12ZB-12-00006A	法兰夹 FL-12 Clamp	1
3	12ZB-12-06000A	软管总成 Hose	1
4	12ZB-12-05000A	软管总成 Hose	1
5	12ZB-12-00002A	接头 1CH-22-20 Adapter	1
6	12ZB-12-05000	单向阀 DIF-L10H Slide	1
7	12ZB-12-00002	垫圈 Washer	1
8	12ZB-12-02000	滤油器 Return filter	1
9	12ZB-12-01000	滤油罩 Cover	1
10	16Z-15-03000	转向柱 Steering wheel	1
11	12ZB-12-00003A	接头 1CH-22-18 Adapter	4
12	12ZB-12-03000A	软管总成 Hose	1
13	12ZB-12-04000A	软管总成 Hose	1
14	16Z-15-10000	软管总成 Hose	2
15	12ZB-12-00004A	接头 1CH-22-18 Adapter	2
16	12ZB-12-00005A	接头 FL-12 Adapter	2
17	18J-16-20000	转向油缸 Steering cylinder	2
18	16Z-15-04000	方向盘 Steering shaft	1
19	01010-51025	螺栓 Bolt	4
20	01643-51032	垫圈 Washer	4
21	16Z-15-02000	转向器 Steering unit	1

第 506 图 连杆装配

FIG.506 LINK ASSEMBLY

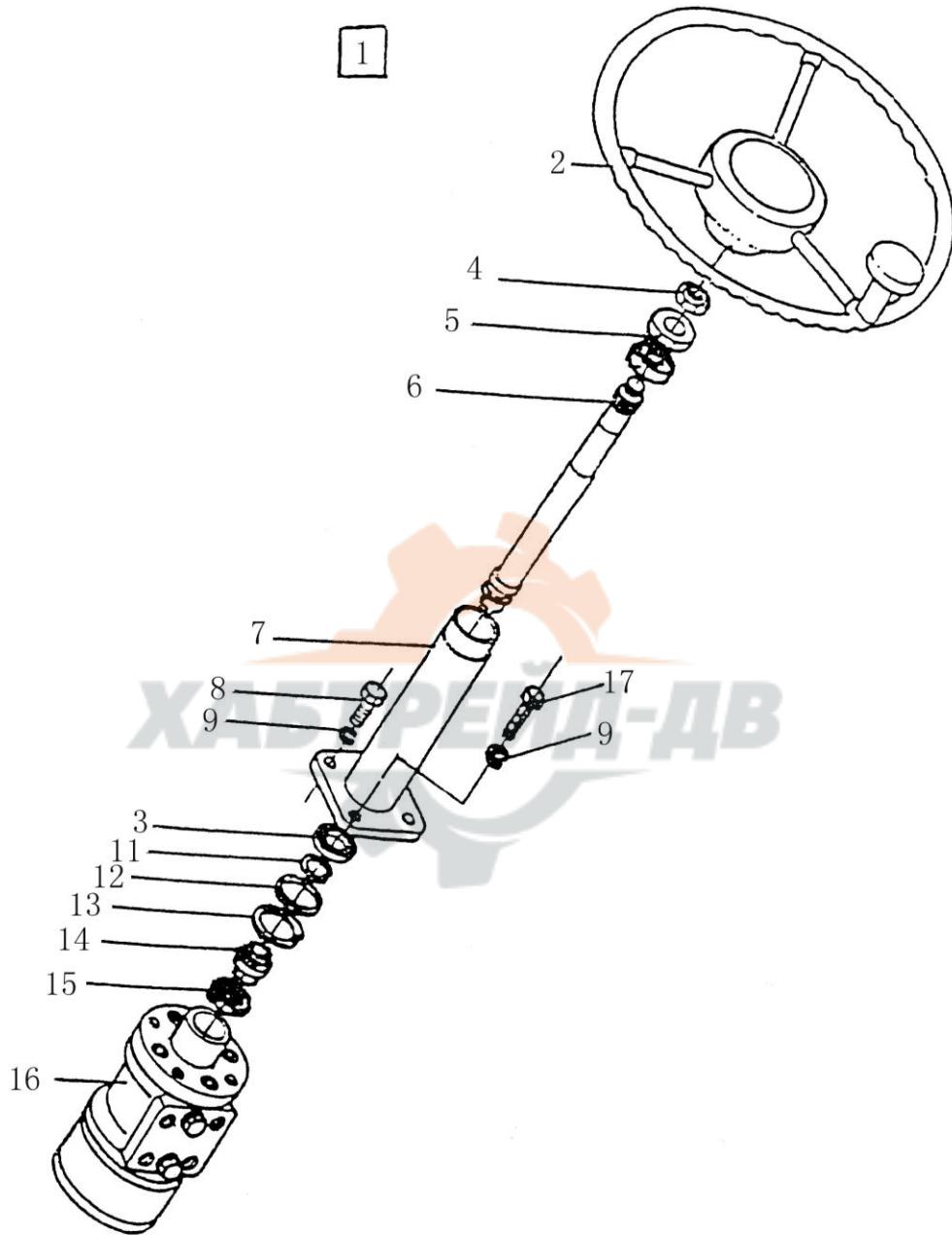

连杆装配
LINK ASSEMBLY

序号 Index NO.	代 号 Par NO.	名 称 Name	数量 Q'ty
1	16Z-15-04000	方向盘总成 Steering wheel	1
2		方向盘 Steering	1
3		钢球 $\phi 3$ Steel ball	54
4	01582-01613	螺母 M16*1.5 Nut	54
5		尼龙套 Nylon cover	1
6		轴 Steering shaft	1
7		支承管 Steering tube	1
8	01010-31020	螺栓 M10*20 Bolt	2
9	01602-51030	弹簧垫圈 10 Washer	4
11		挡圈 Retainer ring	1
12		调整垫圈 Washer	1
13		挡圈 $\phi 35$ Retainer ring	1
14		球座 Ball joint	1
15		球碗 Socket	2
16		转向阀 BZZ1-500 Steering unit	1
17	01010-31035	螺栓 M10*35 Bolt	2

第 506 图 转向油缸总成 (1/2)

FIG.506 STEERING CYLINDER ASSEMBLY

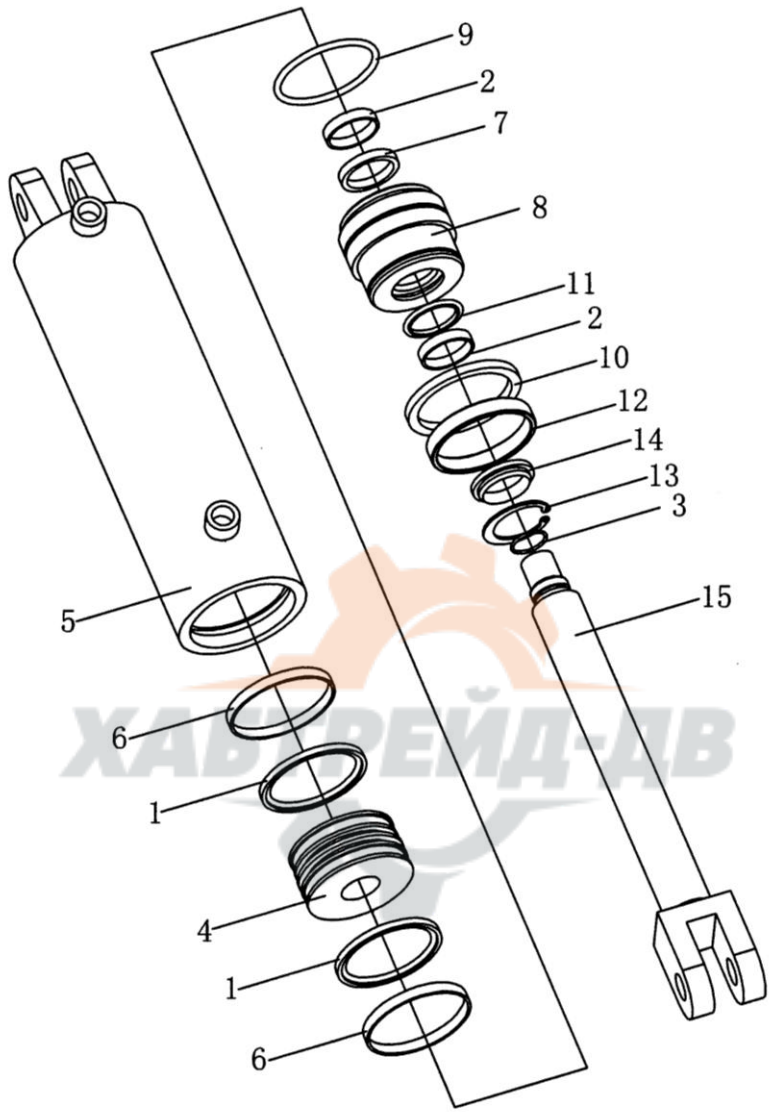

转向油缸总成 (1/2)

STEERING CYLINDER ASSEMBLY

序号 Index NO.	代 号 Par NO.	名 称 Name	数量 Q'ty
1	CKW100	孔用组合密封 Ring	2
2	WD100×9.4×2.5	支承环 Retaining ring	2
3	GB1235-76/φ35×3.1	O形圈 Loop ring	1
4	16Z-15-09001-02	活塞 Piston	1
5	16Z-15-09001-03	缸体 Cylinder	1
6	WD50×9.4×2.5	支承环 Retaining ring	2
7	CKG45	轴用 Y 形密封 Y type seal	1
8	16Z-15-09001-04	导向套 Sheath	1
9	GB1235-76/φ100×5.7	O形圈 Loop ring	1
10	YZ18-14-12-6	孔用卡键 Key for hole	1
11	CKS45	轴用组合密封 Washer for shaft	1
12	YZ18-14-12-7	挡环 Seal ring	1
13	GB894.1-86/φ90	轴用弹性挡圈 Stretch washer	1
14	CK45	防尘圈 Ring	1
15	16Z-15-09001-05	活塞杆 Piston rod	1

第 507 图 转向油缸总成 (2/2)

FIG.507 STEERING CYLINDER ASSEMBLY

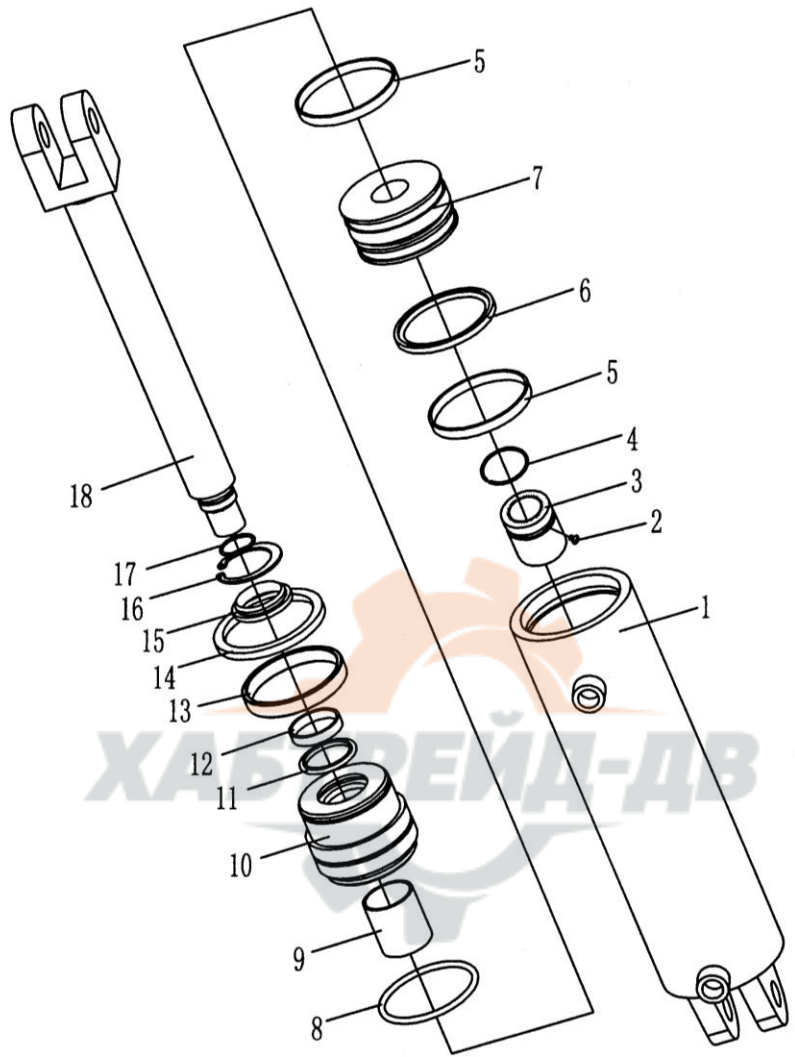

转向油缸总成 (2/2)

STEERING CYLINDER ASSEMBLY

序号 Index NO.	代 号 Par NO.	名 称 Name	数量 Q'ty
1	18J-16-20001	缸体 Cylinder	1
2	GB71-85-M10*1	开槽锥端紧定螺钉 Screw	1
3	18J-16-20002	螺母 Nut	1
4	18J-16-20003	钢丝圈 $\phi 50 \times 1$ Steel wire	1
5	18J-16-20004	支承环 $100 \times 9.5 \times 2.5$ Retaining ring	2
6	18J-16-20005	格莱圈 $\phi 100 \times 6$ Seal ring	1
7	18J-16-20006	活塞 Piston	1
8	18J-16-20007	O 型圈 $D100 \times 3.1$ O-ring	1
9	SF-1-6040	衬套 Sheath	1
10	18J-16-20008	导套 Sheath	1
11	18J-16-20009	斯特封 $\phi 45 \times 4$ Seal ring	1
12	18J-16-20010	Y 型圈 $45 \times 53 \times 6$ Y type ring	1
13	18J-16-20011	挡圈 Retaining ring	1
14	18J-16-20012	卡键 Key for hole	1
15	18J-16-20013	除尘圈 $45 \times 53 \times 5/6.5$ Seal ring	1
16	04069-00902	轴用弹性挡圈 Retaining ring for shaft	1
17	18J-16-20014	O 型圈 O-ring	1
18	18J-16-20015	活塞杆 Piston rod	1

发动机关联部件

ENGINE RELATED PARTS



第 101 图 发动机及附件安装

FIG.101 ENGINE ASSEMBLY

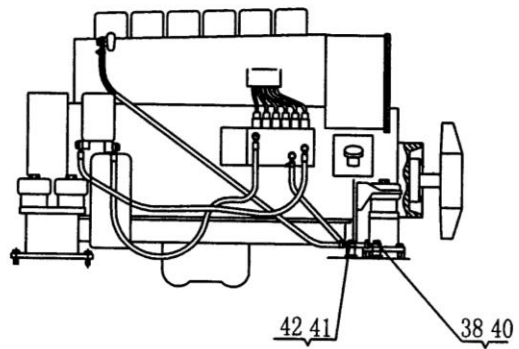
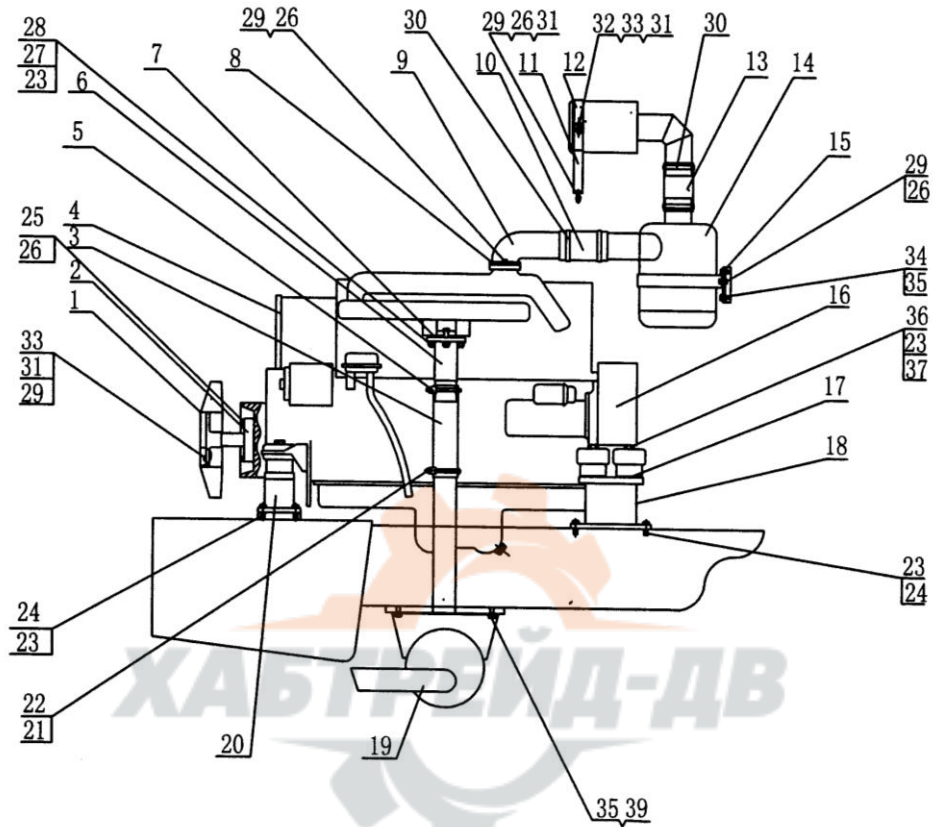

发动机及配件安装

ENGINE ASSEMBLY

序号 Index NO.	代 号 Par NO.	名 称 Name	数量 Q`ty
1	12ZB-01-01000	风扇 Fan	1
2	12ZB-01-02000	风扇轴 Drive shaft	1
3	12ZB-01-00002	膨胀节 Exhaust hose	1
4	12ZB-01-00003	密封条 Seal	1
5	12ZB-01-00010	座 Seat	2
6	12ZB-01-03000	座 Seat	1
7	12ZB-01-00004	密封垫 Washer	1
8	12ZB-01-00005	垫片 Washer	1
9	12ZB-01-04000	弯管 Hose	1
10	12ZB-01-00006	软管 Hose	1
11	12ZB-01-05000	空滤器下支架 Bracket	1
12	12ZB-01-00007	空滤器上支架 Bracket	1
13	12ZB-01-06000	空滤器 Air cleaner	1
14	12ZB-01-00008	软管 Hose	1
15	12ZB-01-00009	板 Plate	1
16	12ZB-01-07000	发动机 Engine	1
17	12ZB-01-00011	垫片 Washer	12
18	12ZB-01-08000	前支座 Engine bracket	2
19	12ZB-01-09000	消音器 Muffler	1
20	12ZB-01-10000	后支座 Engine bracket	2
21	01599-01011	螺母 Nut	4
22	07283-27663	U 型管夹 Clamp	2
23	01602-21236	垫圈 Washer	9
24	01016-51235	螺栓 Bolt	16
25	01010-50830	螺栓 Bolt	8
26	01641-20812	垫圈 Washer	16
27	01580-11210	螺母 Nut	3
28	01016-51250	螺栓 Bolt	3
29	01010-50820	螺栓 Bolt	12
30	07281-00909	喉箍 Hose clip	4

发动机及配件安装

ENGINE ASSEMBLY

序号 Index NO.	代 号 Par NO.	名 称 Name	数量 Q'ty
31	01580-10806	螺母 Nut	8
32	01010-50830	螺栓 Bolt	2
33	01602-20825	垫圈 Washer	6
34	01010-51020	螺栓 Bolt	4
35	01643-31232	垫圈 Washer	8
36	01010-51290	螺栓 Nut	6
37	01643-21232	垫圈 Washer	22
38	07206-21014	螺栓 Bolt	1
39	01010-51025	螺栓 Bolt	4
40	07005-01412	密封垫圈 Washer	2
41	07005-00812	密封垫圈 Washer	2
42	07206-20508	螺栓 Bolt	1

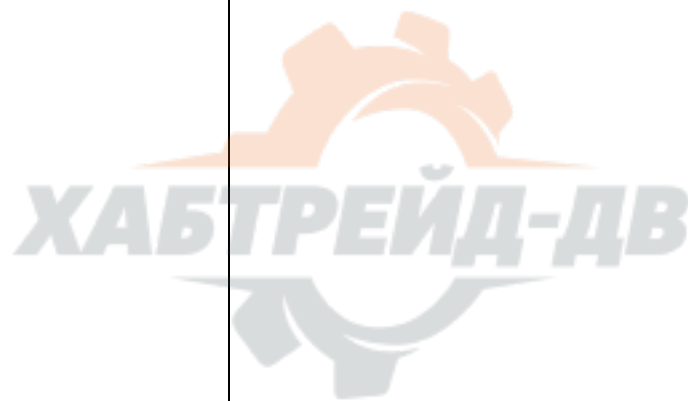

第 102 图 操纵系统

FIG.102 CONTROL SYSTEM

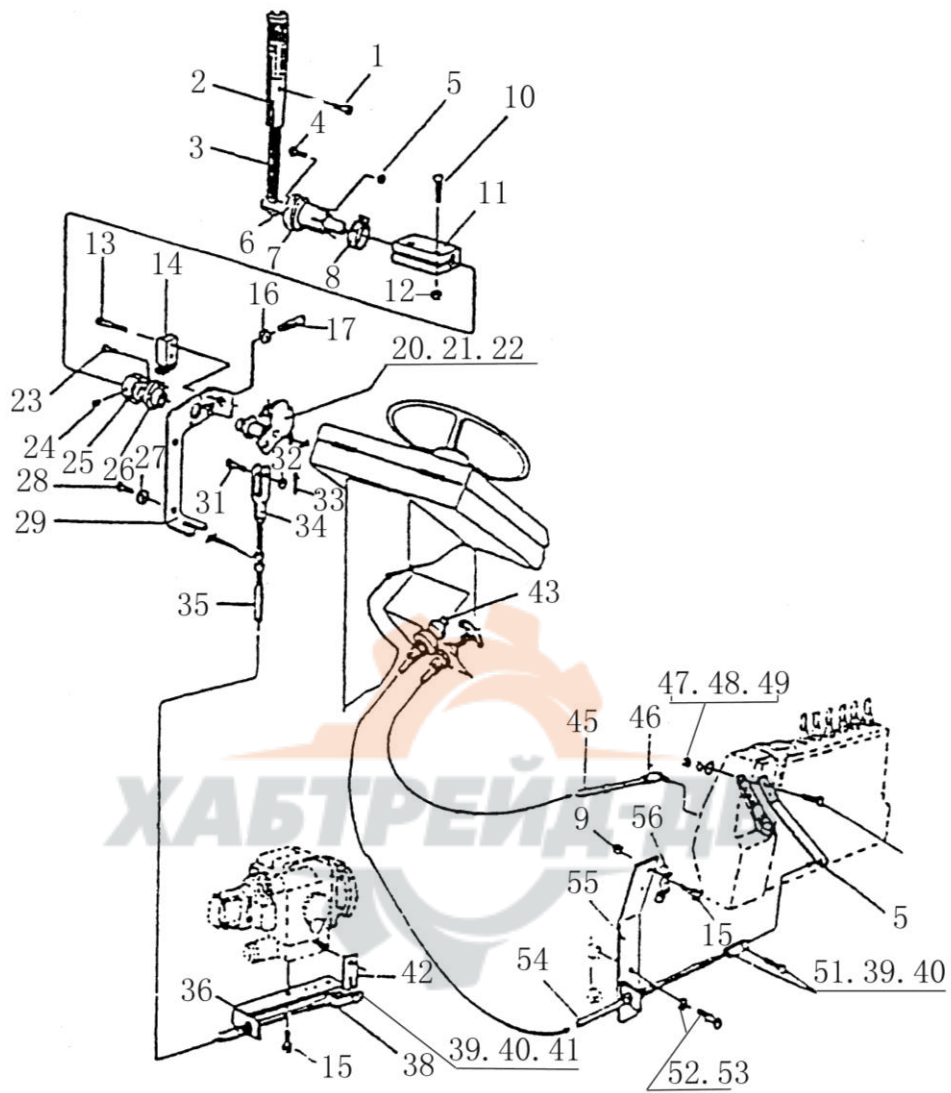

操纵系统

CONTROL SYSTEM

序号 Index NO.	代 号 Par NO.	名 称 Name	数量 Q'ty
1	GB65-76	螺钉 M3*6 Screw	1
2		手柄 Handel	1
3		控制杆 Lever	2
4	GB30-76	螺母 M6 Nut	4
5	GB52-76	螺母 M6 Nut	4
6		垫板 Washer	1
7		衬套 Bushing	1
8	OX(19-29)	胶管卡箍 Hose clamp	1
9	GB52-76	螺母 M5 Nut	3
10	GB30-76	螺栓 M8*35 Bolt	2
11		联结器体 Coupling	1
12	GB52-76	螺母 M8 Nut	2
13	GB65-76	螺钉 M5*6 Screw	2
14	JW12-11	微动开关 Switch	1
15	GB65-76	螺钉 M5*16 Screw	2
16	GB52-76	螺母 M6 Nut	2
17	GB72-76	螺钉 M6*40 Screw	2
20		限位器 Limiter	1
21		弹性球头螺钉 M16*1.5 Screw	1
22	GB52-76	螺母 M16*1.5 Nut	1
23	GB30-76	螺栓 M5*10 Bolt	2
24	GB78-76	螺钉 M8*12 Screw	1
25		制子 Ring	1
26		衬套 Bushing	1
27	GB97-76	垫圈 8 Washing	2
28	GB30-76	螺栓 M8*16 Bolt	2
29		支架 Bracket	1
31	GB882-76	销轴 ϕ 8*25 Pin	1
32	GB848-76	垫圈 8 Washer	1
33	GB91-76	开口销 3*16 Pin	1
34	12ZB-19-00001	叉口板 Fork link	1
35	12ZB-19-00008	换向软轴总成 Control cable	1

操纵系统

CONTROL SYSTEM

序号 Index NO.	代 号 Par NO.	名 称 Name	数量 Q'ty
36	12ZB-19-10000	固定板 Bracket	1
38	12ZB-19-00002	叉口板 Fork link	1
39	04205-10624	销轴 $\phi 6*24$ Pin	2
40	04050-12012	开口销 2*12 Pin	2
41	01641-20608	垫圈 6 Washer	2
42		联结板 Link	1
43	12ZB-19-00007	油门软轴总成 Control cable	1
44	01641-20608	垫圈 6 Washer	2
45	12ZB-19-00006	熄火软轴总成 Control cable	1
46	12ZB-19-00004	叉口板 Fork link	1
47	01641-20608	垫圈 6 Washer	2
48	01580-10605	螺母 M6 Bolt	2
49	01016-30620	螺栓 M6*20 Bolt	2
50	12ZB-19-00003	固定板 Bracket	1
51	12ZB-19-00002	叉口板 Fork link	1
52	01016-30820	螺栓 M8*20 Bolt	2
53	01641-20812	垫圈 8 Washer	2
55	12ZB-19-20000	固定板 Bracket	1
56	12ZB-19-00005	压板 Bracket	1

第 103 图 分动箱装配

FIG.103 WHEEL BOX ASSEMBLY

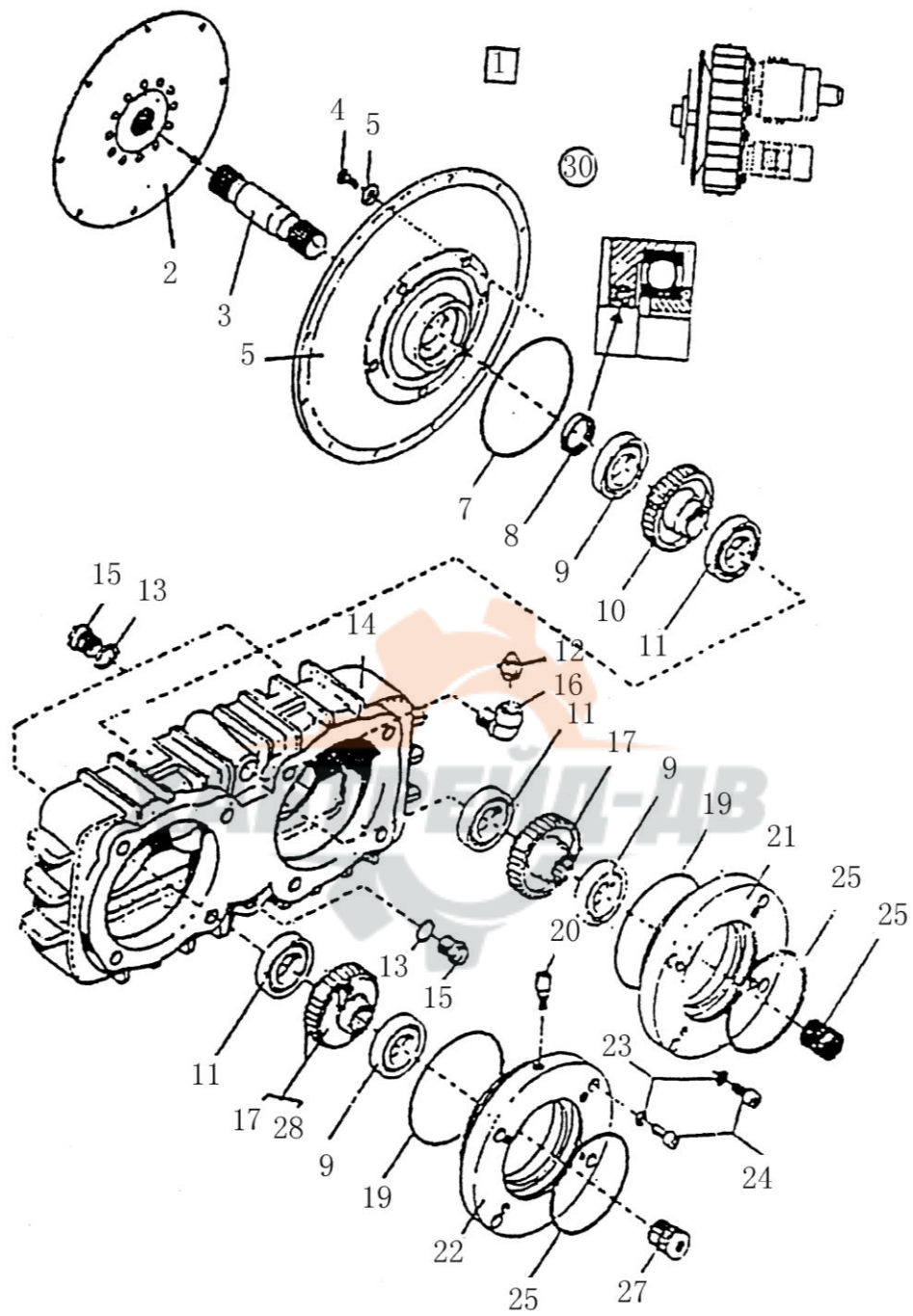

分动箱装配

WHEEL BOX ASSEMBLY

序号 Index NO.	代 号 Par NO.	名 称 Name	数量 Q'ty
1	12Z-02-00000	分动箱装配 Wheel box assembly	1
2	12Z-02-01000	驱动圆盘 Drive plate	1
3	12Z-02-00007	花键轴 Spline shaft	1
4	01010-31640	螺钉 M16*40 Bolt	6
5	01602-01648	垫圈 16 Spring Washer	6
6	12Z-02-00001	联接盘 Connected cover	1
7	07000-05165	O 型密封圈 165*5.7 O-ring	1
8	07011-60060	骨架油封 Sell ring	1
9	GB276-82	轴承 213 Bearing	3
10	12Z-02-00006	主动斜齿轮 Drive gear	1
11	GB276-82	轴承 211 Bearing	3
12	12Z-02-00013	螺塞 Plug	3
13	07002-02034	O 型圈 16.7*3.4 O-ring	3
14	12Z-02-00002	箱体 Horsing	1
15	07040-12012	螺塞 Plug	3
16	12Z-02-00012	内外弯头 Elbow90	1
17	12Z-02-00004	从动斜齿轮 Gearing	2
19	07000-02145	O 型圈 145*3.1 O-ring	2
20	12Z-02-00011	螺塞 Plug	1
21	12Z-02-00003	轴承盖 Bearing housing	1
22	12Z-02-00009	轴承盖 Bearing housing	1
23	01602-01236	垫圈 12 Spring Washer	8
24	01252-31230	螺钉 M12*30 Screw	8
25	07000-12125	O 型圈 D125*3.1 O-ring	2
26	12Z-02-00005	变量泵联接套 Variable pump sleeve	1
27	12Z-02-00008	齿轮泵联接套 Gearing pump sleeve	1
28	12Z-02-02002	甩油盘 Oil slinger	1

防护装置

GUARD EQUIPMENT



第 401 图 地板架总成

FIG.401 FLOOR ASSEMBLY

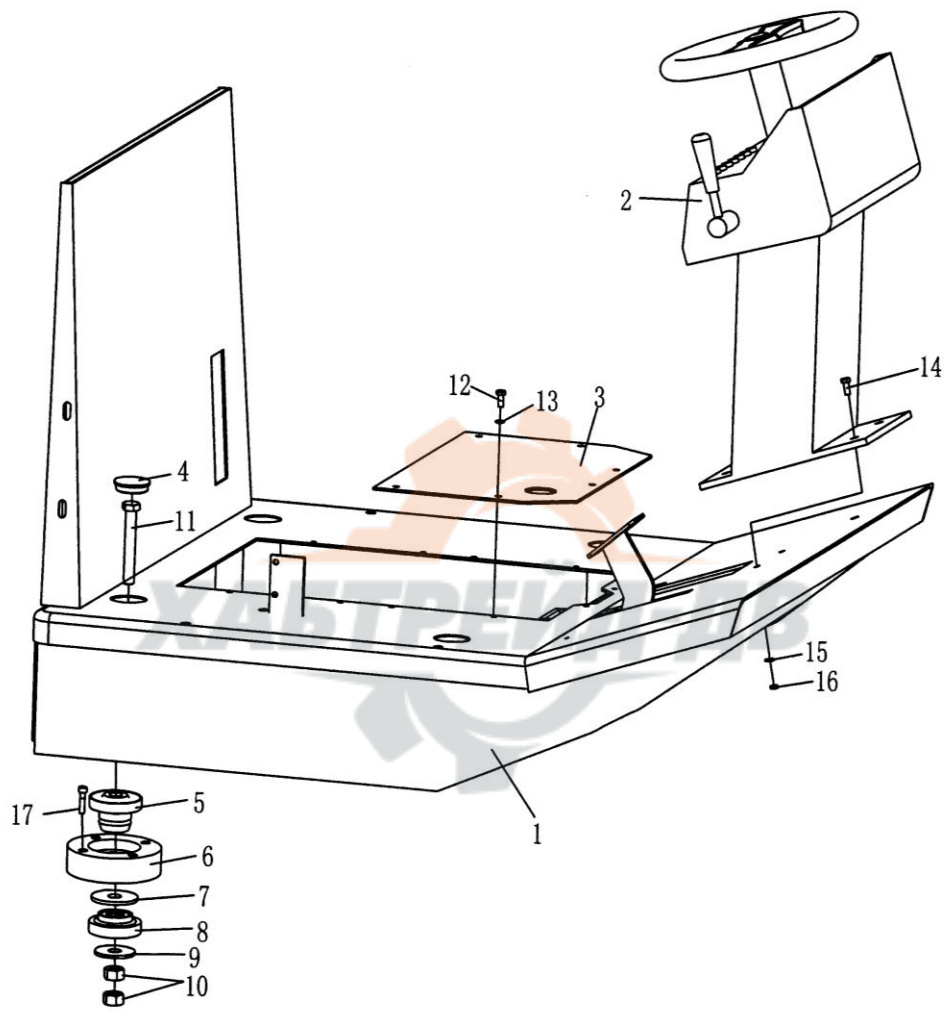

地板架总成

FLOOR ASSEMBLY

序号 Index NO.	代 号 Par NO.	名 称 Name	数量 Q'ty
1	12ZB-13-01000	地板架 Floor	1
2	12ZB-13-02000	仪表盘 Instrument box	1
3	12ZB-13-00001	盖板 Plate	1
4	16Z-07-00002	塞子 Plug	6
5	18J-07-03000	上减振器 Shock absorber	4
6	12ZB-13-00002	减振器座 Shock absorber seat	4
7	18J-07-00001	调整垫(1) Washer	4
8	18J-07-02000	下减振器 Shock absorber	4
9	18J-07-00003	调整垫(2) Washer	8
10	01580-12419	螺母 M24 Nut	8
11	01011-52450	螺栓 M24×150 Bolt	4
12	01016-30820	螺栓 M8×20 Bolt	6
13	01643-30823	垫圈 8 Washer	6
14	01016-31025	螺栓 M10×25 Bolt	4
15	01643-31032	垫圈 10 Washer	4
16	01580-11008	螺母 M10 Nut	4
17	01252-51045	螺栓 M10×45 Bolt	8

第 402 图 驾驶室总成

FIG.402 CAB ASSEMBLY

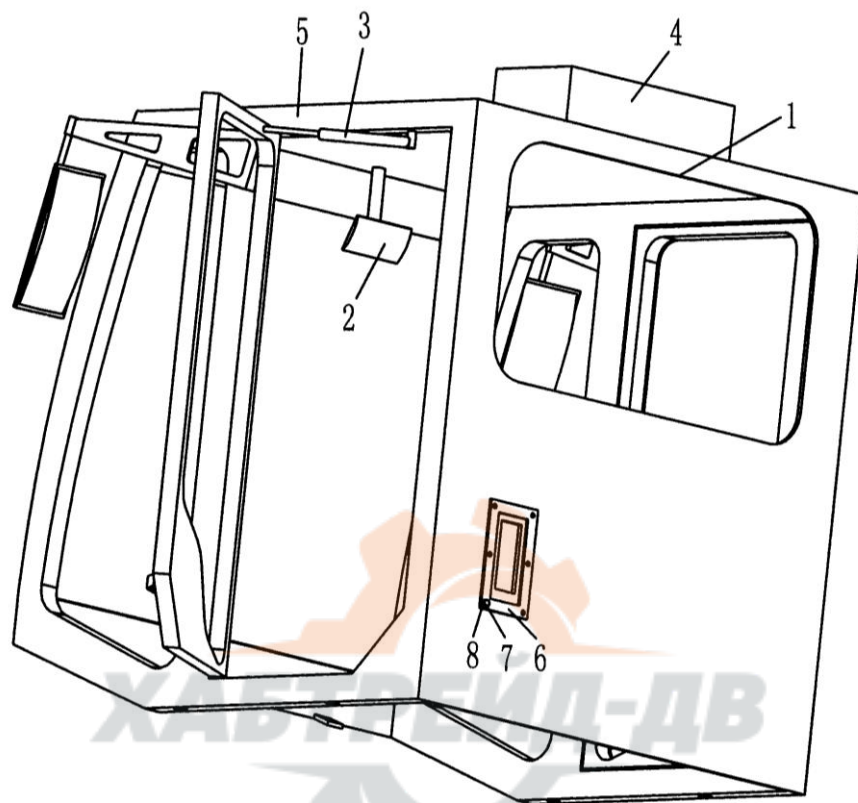

驾驶室总成
CAB ASSEMBLY

序号 Index NO.	代 号 Par NO.	名 称 Name	数量 Q'ty
1	12ZB-11-03000	后铝窗 Back window	1
2	16Z-08-06000	内视镜 Inside mirror	1
3	16Z-08-07000	气弹簧 Gas spring	2
4	12ZB-11-04000	天窗 Top window	1
5	12ZB-11-01000A	框架 Frame	1
6	12ZB-11-00001A	圈 Washer	1
7	01010-00620	自攻螺钉 Bolt	6
8	01580-00605	螺母M6 Nut	6



第 403 图 后机罩总成

FIG.403 ENGINE HOOD ASSEMBLY

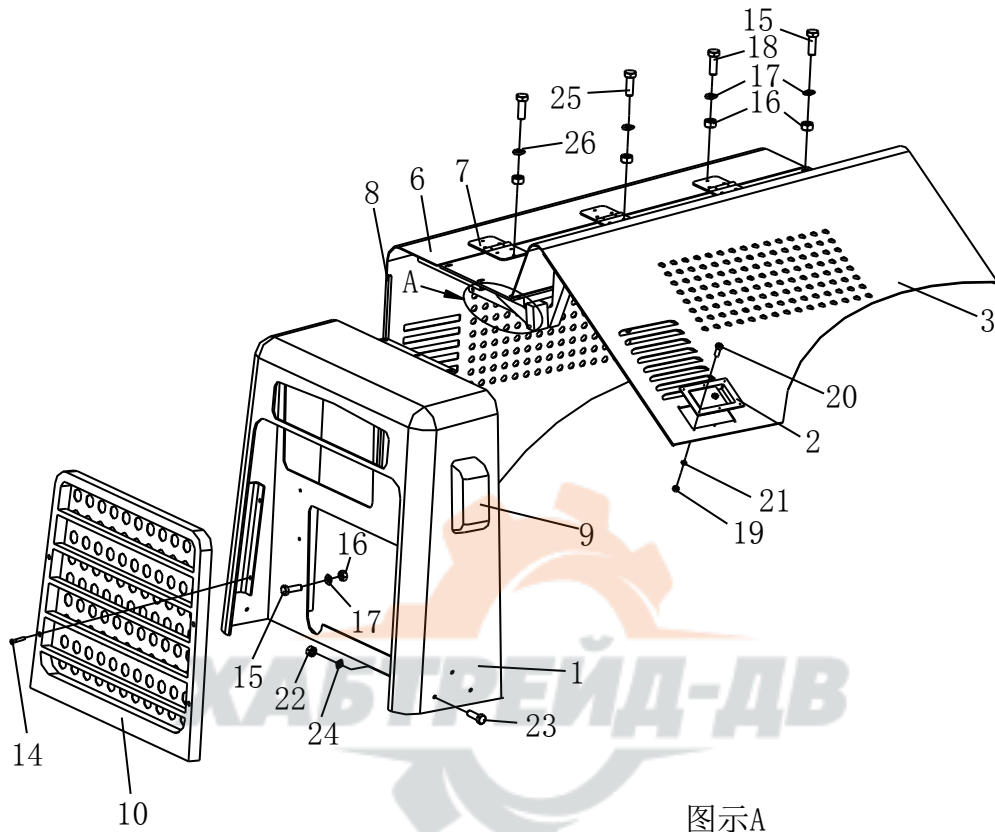

图示A
Detail A

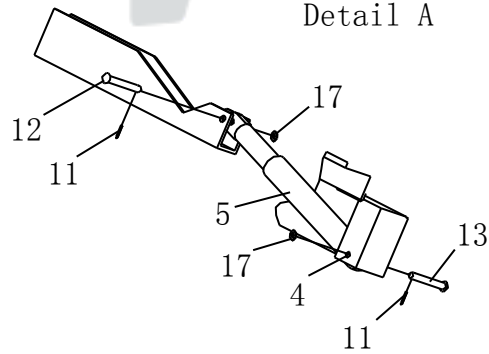

后机罩总成

ENGINE HOOD ASSEMBLY

序号 Index NO.	代 号 Par NO.	名 称 Name	数量 Q'ty
1	12ZB-15-01000	油冷器罩 Radiator frame	1
2	12ZB-15-02000	门锁 Door lock	2
3	12ZB-15-03000	右护罩 Right roof	1
4	12ZB-15-00004	调整套 Sleeve	2
5	12ZB-15-04000	气弹簧 Pneumatic spring	2
6	12ZB-15-05000	上护罩 Hood roof	1
7	12ZB-15-06000	合页 Hinge	6
8	12ZB-15-07000	左护罩 Left roof	1
9	12ZB-15-09000	转向灯 Lamp	2
10	12ZB-15-10000	格栅 Grid	1
11	04050-02016	开口销 Cotter pin	4
12	04205-10840	销轴 8×40 Pin	2
13	04205-10860	销轴 8×60 Pin	2
14	01252-40845	内六角圆头螺栓 M8×45 Bolt	4
15	01010-30830	螺栓 M8×30 Bolt	16
16	01580-00806	螺母 M8 Nut	46
17	01643-30832	垫圈 8 Washer	56
18	01010-30850	螺栓 M8×50 Bolt	30
19	01580-60403	螺母 M4 Nut	12
20	01212-50412	开槽圆柱头螺钉 M4×12 Screw	12
21	01641-20405	垫圈 4 Washer	12
22	01580-01008	螺母 M10 Nut	6
23	01010-31030	螺栓 M10×30 Bolt	6
24	01643-31032	垫圈 10 Washer	6
25	01010-30845	螺栓 M8×45 Bolt	12
26	01010-30820	螺栓 M8×20 Bolt	6

第 404 图 司机座

FIG.404 SEAT

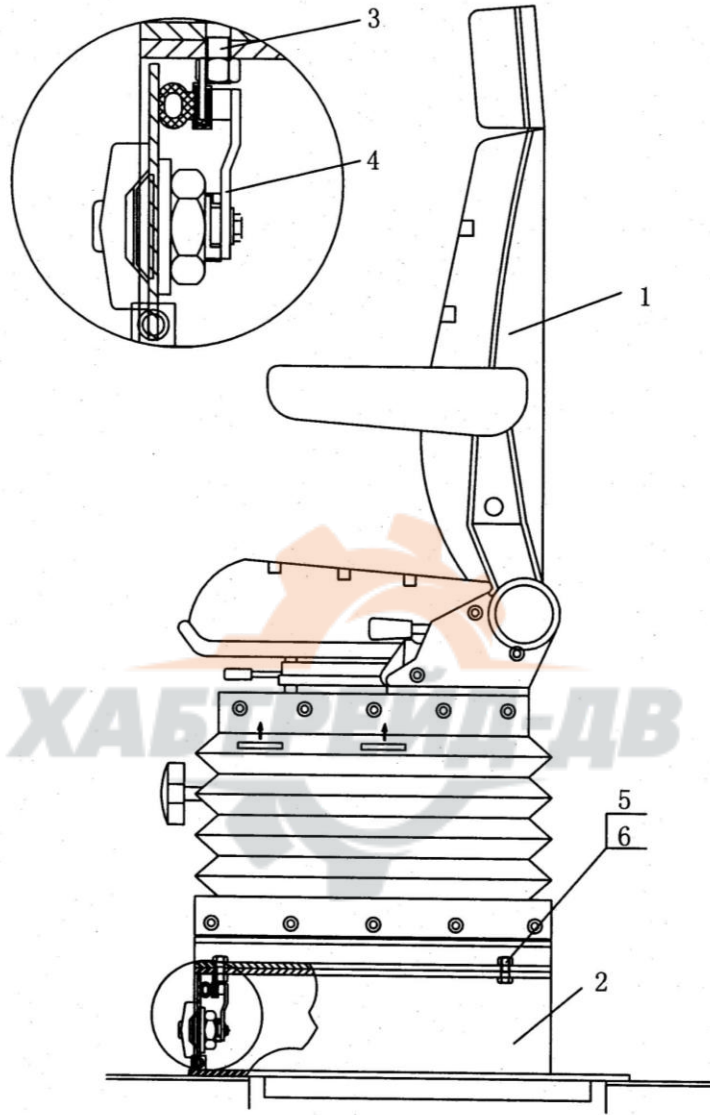

司机座

SEAT

序号 Index NO.	代 号 Par NO.	名 称 Name	数量 Q'ty
1	20J-09-01000	司机座 Seat	1
2	12ZB-20-02000	工具箱 Tool box	1
3	20J-09-00001	缓冲橡胶 Rubber washer	1
4	20J-09-03000	工具箱锁 Box lock	1
5	01010-30825	螺栓 M8×25 Bolt	8
6	01643-30823	垫圈 8 Washer	8



主机架及工作装置

MAIN FRAME AND WORK EQUIPMENT



第 301 图 前机架总成 (SR12、YZ12B)

FIG.301 DRUM FRAME ASSEMBLY

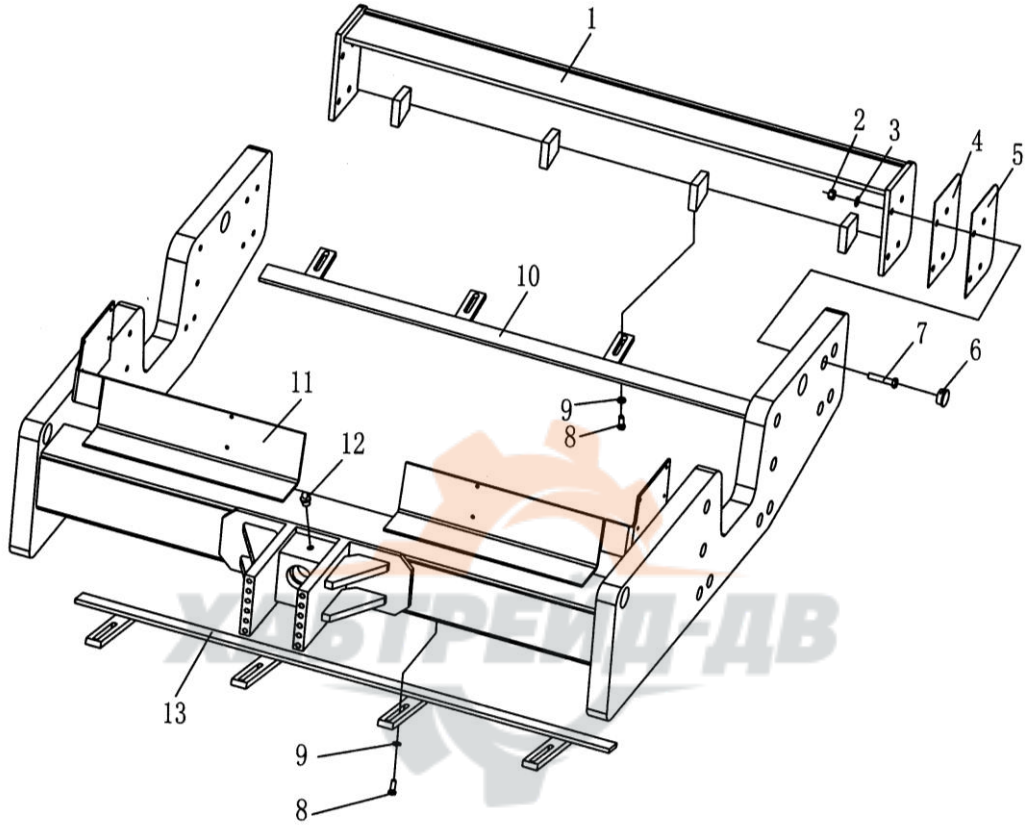

前机架总成 (SR12、YZ12B)

DRUM FRAME ASSEMBLY

序号 Index NO.	代 号 Par NO.	名 称 Name	数量 Q'ty
1	12ZB-08K-30000	前刮泥板支架 Bracket Front	2
2	01580-12016	螺母 M20 Nut	8
3	01643-32060	垫圈 20 Washer	8
4	12ZB-08-00001	垫片 Shim	2
5	12ZB-08-00002	垫片 Shim	2
6	12ZB-08-00003	胶套 Sheath	24
7	01011-52010	螺栓 M20*100 Bolt	8
8	01010-51645	螺栓 M16*45 Bolt	12
9	01643-31645	垫圈 16 Washer	12
10	19ZK-04-30000	刮泥板 Scraper	1
11	SR12-04K-10000	前机架 Frame front	1
12	07020-01021	油杯 M10*1 Grease fitting	1
13	18J-04-30000	前刮泥板 Scraper	1

第 302 图 前机架总成 (SR12P、YZK12B)

FIG.302 DRUM FRAME ASSEMBLY

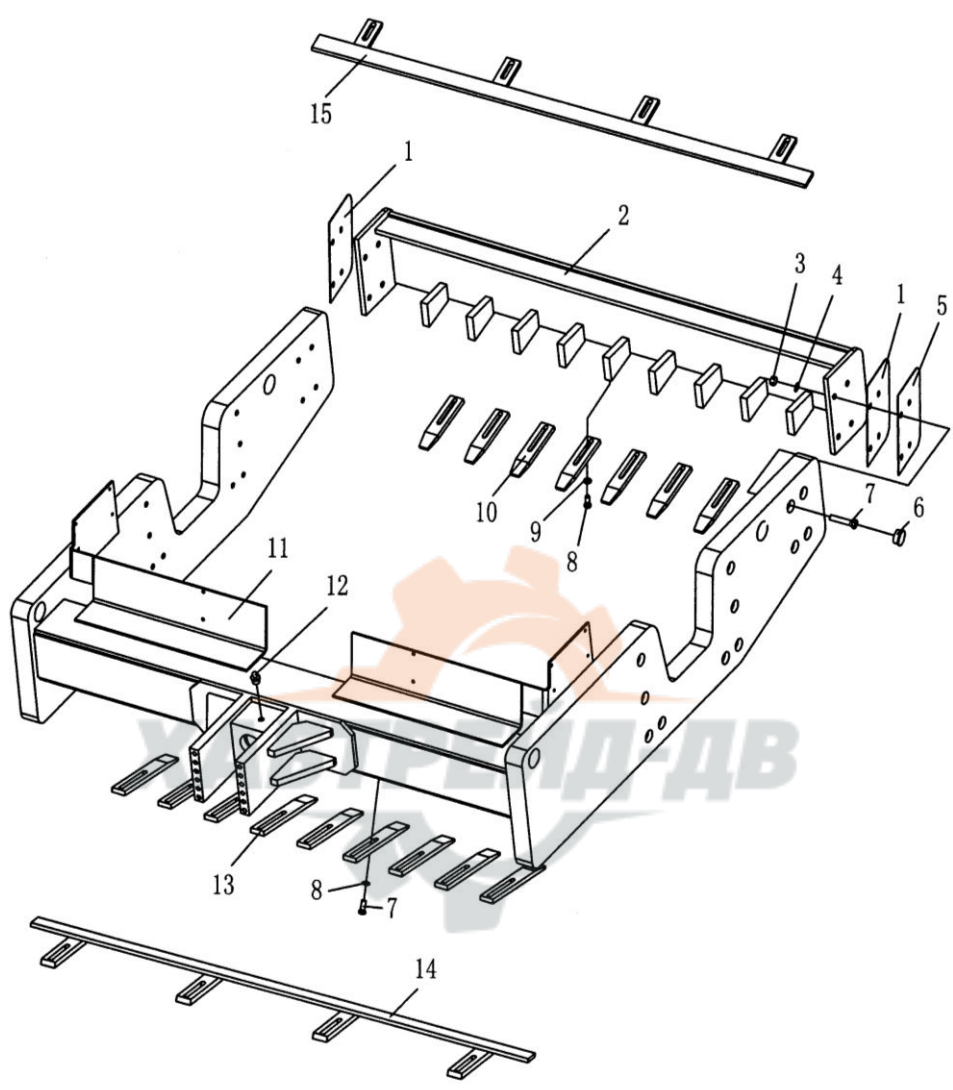

前机架总成 (SR12P、YZK12B)

DRUM FRAME ASSEMBLY

序号 Index NO.	代 号 Par NO.	名 称 Name	数量 Q'ty
1	12ZB-08-00001	垫片 Shim	2
2	12ZB-08K-30000	前刮泥板支架 Bracket front	2
3	01580-12016	螺母 M20 Nut	8
4	01643-32060	垫圈 20 Washer	8
5	12ZB-08-00002	垫片 Shim	2
6	12ZB-08-00003	胶套 Sheath	24
7	01011-52010	螺栓 M20×100 Bolt	8
8	01010-51645	螺栓 M16×45 Bolt	36
9	01643-31645	垫圈 16 Washer	36
10	SR12-04K-00001	刮泥板 Scraper	9
11	SR12-04K-10000	前机架 Frame front	1
12	07020-01021	油杯 M10×1 Grease fitting	1
13	19ZK-04-00001	刮泥板 Scraper	9
14	12ZB-08K-40000	刮泥板 Scraper	1
15	12ZB-08K-20000	刮泥板 Scraper	1

FIG.303 DRUM ASSEMBLY

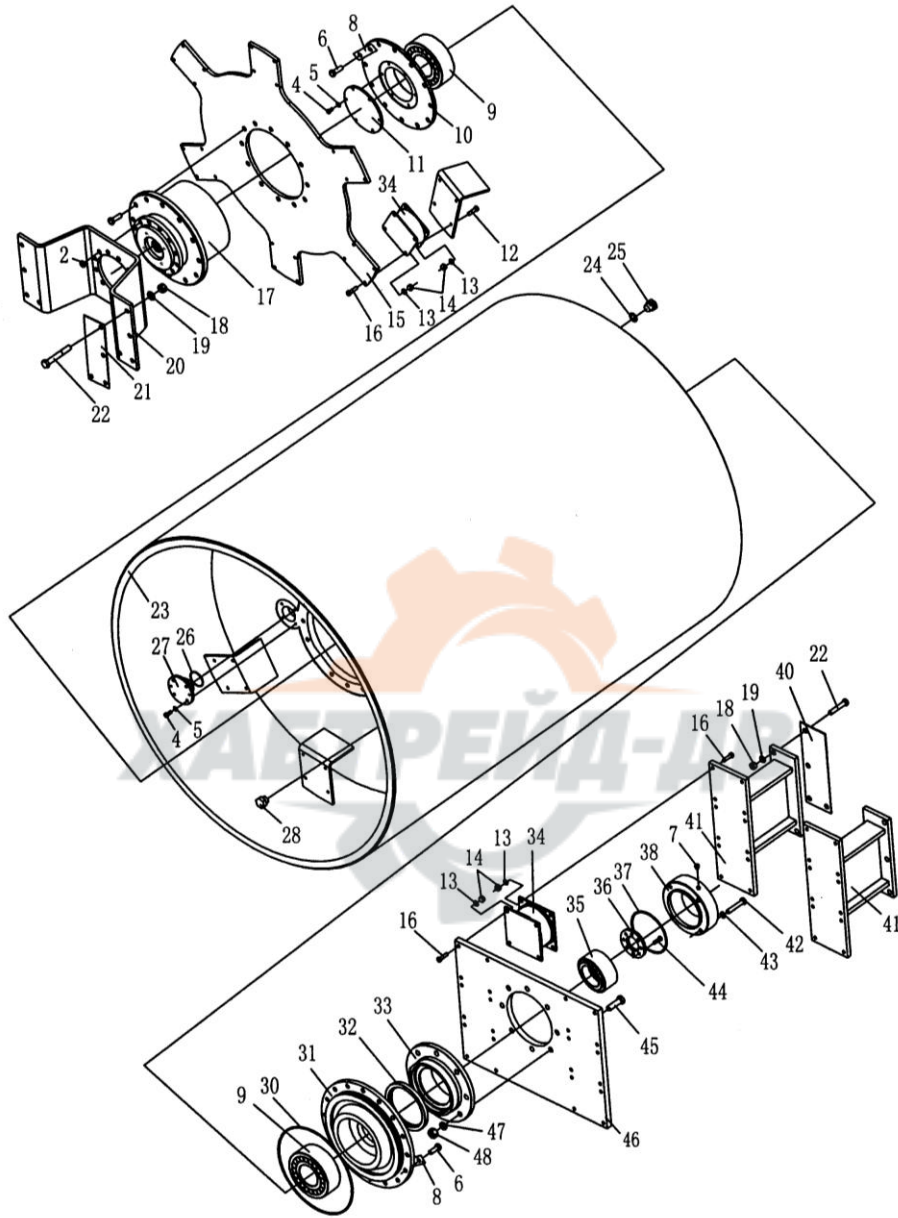

第 304 图 振动轮总成 (2/2)
FIG.304 DRUM ASSEMBLY

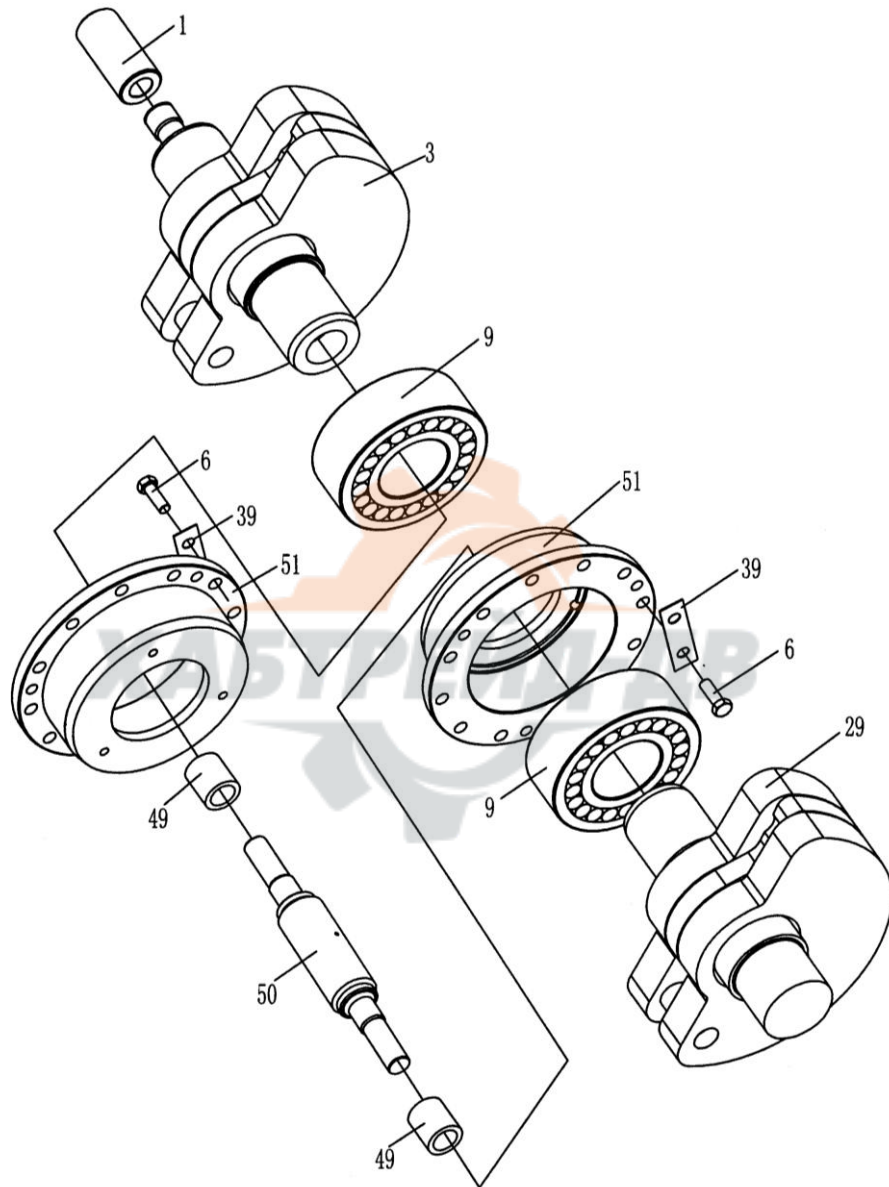

振动轮总成

DRUM ASSEMBLY

序号 Index NO.	代 号 Par NO.	名 称 Name	数量 Q'ty
1	SR12-02-00007	花键套 Spline sheath	1
2	01602-52060	弹簧垫圈 Spring Washer	12
3	SR12-02-40000	右偏心轴 Eccentric shaft right	1
4	01016-31025	螺栓 M10×25 Bolt	10
5	01643-51032	垫圈 10 Washer	10
6	01050-62045	螺栓 M20×1.5×45 Bolt	36
7	07030-00252	通气塞 Plug	1
8	12ZB-09-00005	止动垫片 Stop washer	12
9	SKF	调心滚子轴承 22317 Bearing	4
10	SR12-02-00002	外轴承罩 Hosing	1
11	12ZB-09-00004	轴承盖 Bearing cover	1
12	01016-31235	螺栓 M12×35 Bolt	24
13	01643-31232	垫圈 12 Washer	96
14	01580-01210	螺母 M12 Nut	96
15	12ZB-09-00003	驱动板 Drive plate	1
16	01010-61240	螺栓 M12×40 Bolt	72
17	12ZB-09-10000	减速器 Speed reducer	1
18	01580-02016	螺母 M20 Nut	16
19	01643-32060	垫圈 20 Washer	16
20	SR12-02-00001	转鼓 Torque	1
21	12ZB-09-00024	调整垫片 Regulating washer	3 组
22	01011-62000	螺栓 M20×100 Bolt	16
23	SR12-02-10000	滚轮 Drum	1
24	JB982-77*12	组合垫圈 12 Washer	1
25	16Z-02-00020	六角螺塞 M12*1.25 Hexagonal head	1
26	07000-22065	O 型圈 O-ring	2
27	18JC-02-80000	放油塞 Plug	2
28	18Z-02-90000	视油螺塞 Plug	2
29	SR12-02-20000	左偏心轴 Eccentric shaft left	
30	07000-25370	O 型圈 O-ring	2

振动轮总成

DRUM ASSEMBLY

序号 Index NO.	代 号 Par NO.	名 称 Name	数量 Q'ty
31	SR12-02-00004	右外轴承罩 Housing	1
32	HG4-692-67	油封 SD170×200×18 Seal ring	1
33	SR12-02-00005	轴承罩 Housing	1
34	12ZB-09-30000	减振器 Shock absorber	12
35	GB299-85	双列圆锥滚子轴承 2097722 Bearing	1
36	12ZB-09-00015	盖 Cover	1
37	07000-25185	O 型圈 O-ring	1
38	SR12-02-00008	马达托架 Bracket	1
39	12ZB-09-00007	止动垫圈 Stop washer	6
40	SR12-02-00009	调整垫片 Regulating washer	3 组
41	SR12-02-50000	减振器托架 Bracket	2
42	01016-31250	螺栓 M12×50 Bolt	4
43	01602-51236	垫圈 12 Washer	4
44	01252-61025	内六角螺钉 M10×25 Screw	8
45	01010-61660	螺栓 M16×60 Bolt	8
46	SR12-02-00006	固定板 Fixed plate	1
47	01643-31645	垫圈 16 Washer	8
48	01580-01613	螺母 M16 Nut	8
49	12ZB-09-00010	衬套 Bushing	2
50	SR12-02-30000	驱动轴 Drive shaft	1
51	SR12-02-00003	内轴承罩 Bearing housing inner	1

第 305 图 凸块轮总成 (SR12P、YZK12B)

FIG.305 PAD FEET DRUM ASSEMBLY

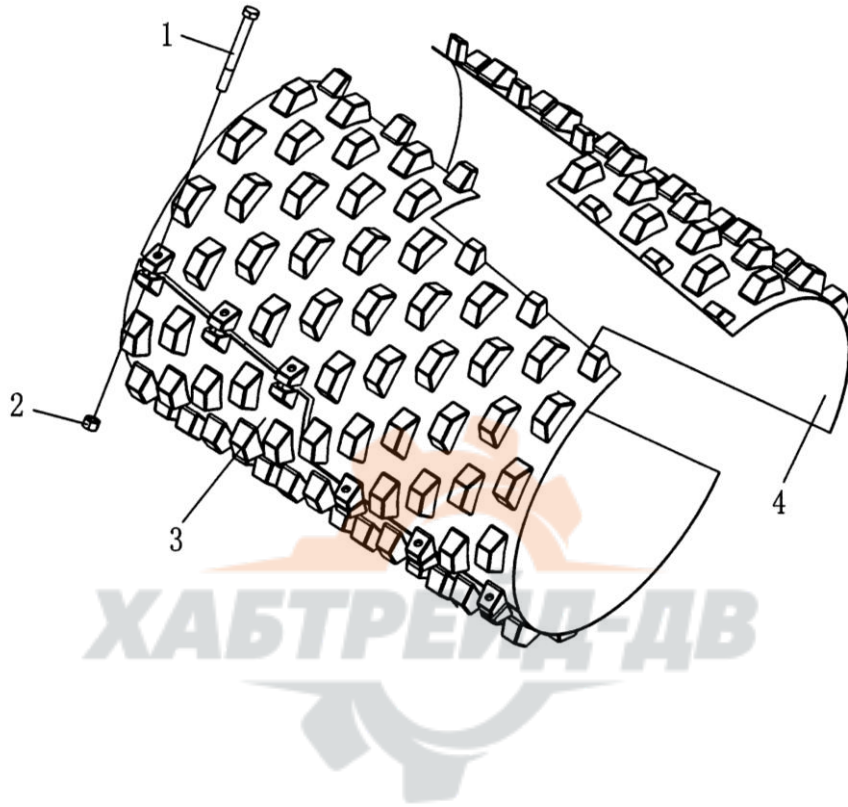

凸块轮总成 (SR12P、YZK12B)

PAD FEET DRUM ASSEMBLY

序号 Index NO.	代 号 Par NO.	名 称 Name	数量 Q'ty
1	19ZK-03-00001	螺栓 Bolt	18
2	19ZK-03-00002	螺母 Nut	18
3	12ZB-24K-01000	弯板(1) Plate	2
4	12ZB-24K-02000	弯板(2) Plate	1

第 306 图 铰接总成

FIG.306 ARTICULATE DEVICE

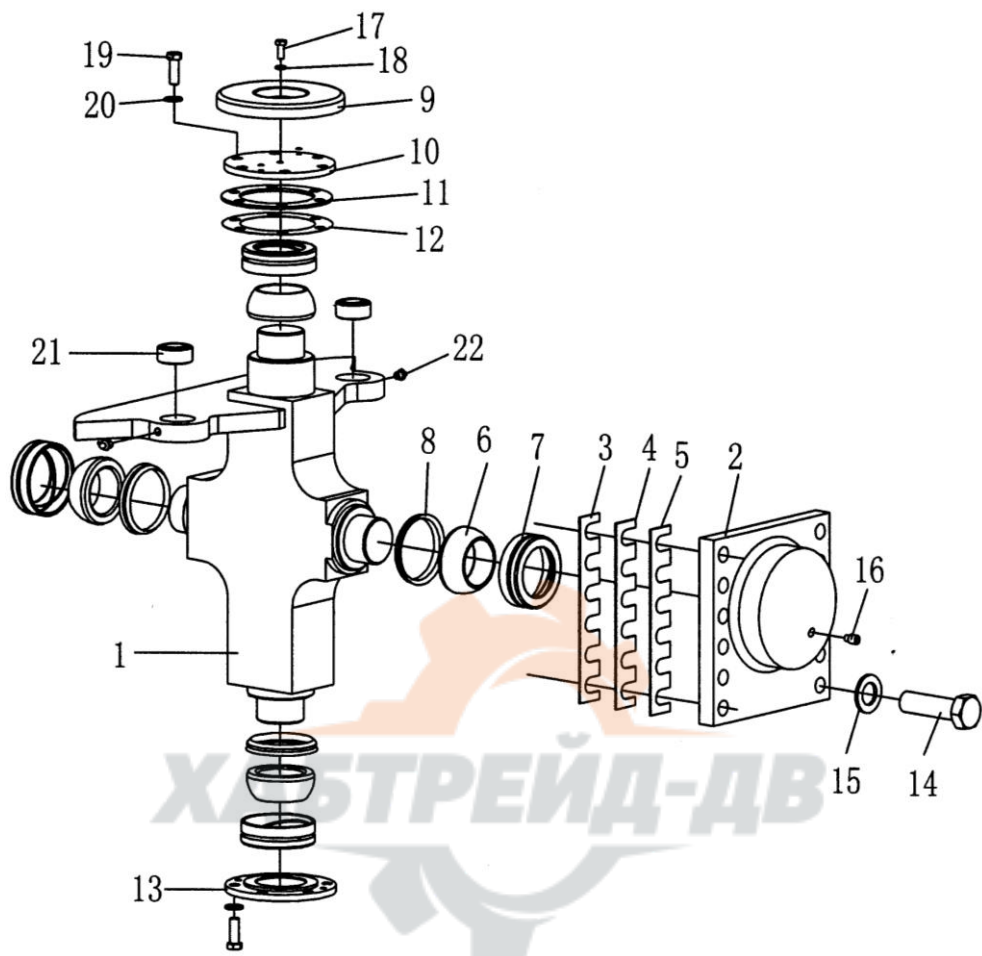

铰接总成

ARTICULATE DEVICE

序号 Index NO.	代 号 Par NO.	名 称 Name	数量 Q'ty
1	18J-06-10000	转向铰链 Steering hitch	1
2	16Z-06-00001	转向铰链盖 Cover	1
3	16Z-06-00002	调整垫片 Regulating shim	2
4	16Z-06-00003	调整垫片 Regulating shim	2
5	16Z-06-00004	调整垫片 Regulating shim	2
6	16Z-06-00005	转向较 Steering hitch	4
7	16Z-06-00006	转向较盖 Steering hitch	4
8	16Z-06-00007	V形密封圈 V-seal ring	3
9	16Z-06-00008	罩盖 Cover	1
10	12ZB-07-00012	盖 Cover	1
11	16Z-06-00010	调整垫片 Regulating shim	2
12	12ZB-07-00011	调整垫片 Regulating shim	1组
13	12ZB-07-00009	盖 Cover	1
14	01010-32070	螺栓 M20×70 Bolt	12
15	01643-32060	垫圈 20 Washer	12
16	01310-21216	螺钉 M12×16 Screw	3
17	01010-30810	螺栓 M8×10 Bolt	1
18	01643-30823	垫圈 8 Washer	1
19	01010-31230	螺栓 M12×30 Bolt	12
20	01643-31232	垫圈 12 Washer	12
21	GB304.6-81	关节轴承 GE30ES-2RS Bearing	2
22	07020-10121	油杯 M10×1 Grease fitting	2

第 307 图 后机架总成

FIG.307 REAR FRAME

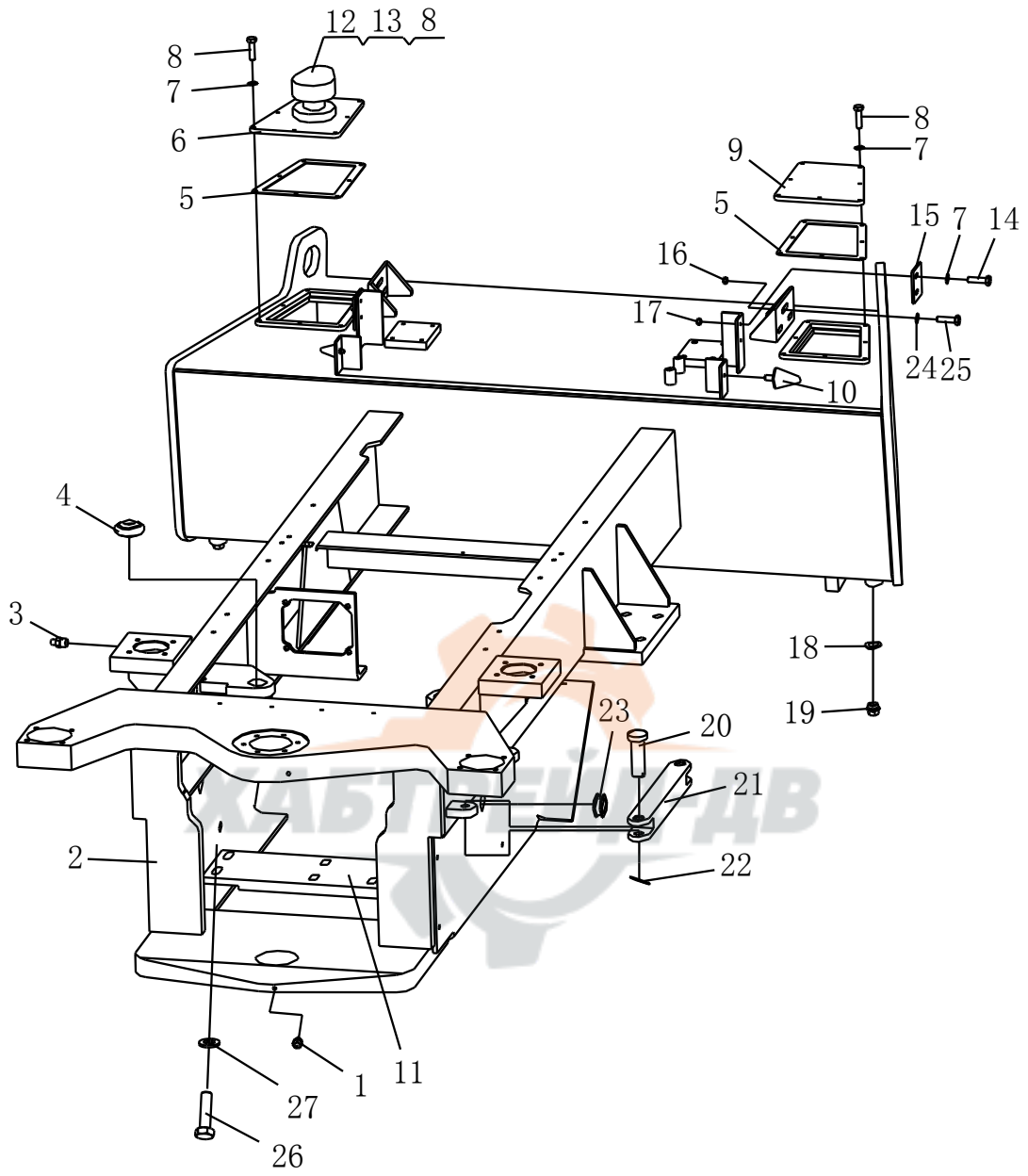

后机架总成
REAR FRAME

序号 Index NO.	代 号 Par NO.	名 称 Name	数量 Q'ty
1	07021-01090	油杯 M10×1 Grease fitting	2
2	12ZB-06-20000	后机架 Rear frame	1
3	07020-01021	油杯 M10×1 Grease fitting	2
4	GB304.6-81	关节轴承 GE30ES-2RS Rod end bearing	2
5	12ZB-06-00006	密封垫 Rubber washer	2
6	12ZB-06-50000	注油口 Fuel lock	1
7	07056-16461	滤网 strainer	1
8	01010-50816	螺栓 M8×16 Bolt	14
9	12ZB-06-00007	盖板 Plate	1
10	18J-05-04000	减振座 Shock absorber seat	2
11	12ZB-06-00009	连接板 plate	1
12	16Y-04C-02000	锁 Lock	
13	12ZB-06-30000	油尺 Oil level	
14	01010-50820	螺栓 M8×20 Bolt	4
15	12ZB-06-00004	锁扣 Lock	2
16	01580-11008	螺母 M10 Nut	6
17	01580-00806	螺母 M8 Nut	6
18	07002-02434	O 型圈 O-ring	2
19	07044-12412	螺塞 Bolt	2
20	16Z-05-00002	销轴 Lock shaft	2
21	12ZB-06-00008	转向锁 Turning lock	1
22	04052-11664	弹簧销 Spring Pin	2
23	12ZB-06-00001	胶套 Sheath	2
24	01643-31032	垫圈 10 Washer	6
25	01010-51035	螺栓 M10×35 Bolt	6
26	01010-51645	螺栓 M16*45 bolt	4
27	01643-31645	垫圈 16 Washer	4

第 308 图 左踏板

FIG.308 LEFT FOOTPLATE

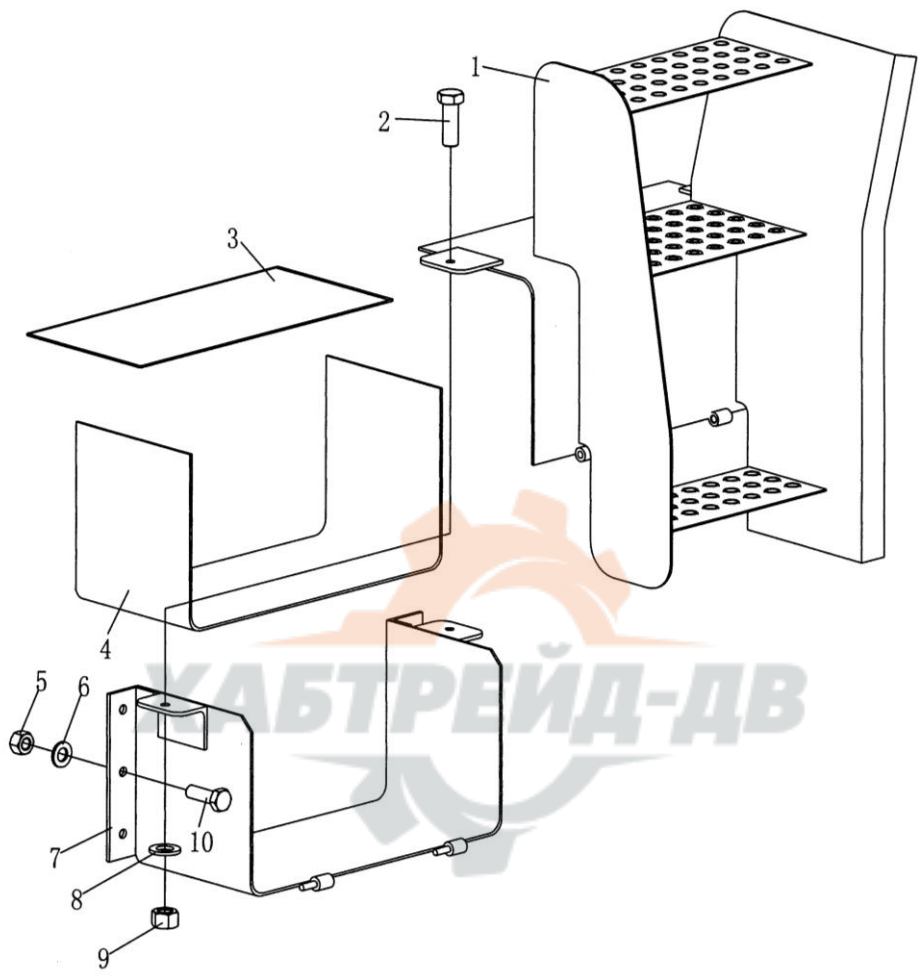

左踏板

LEFT FOOTPLATE

序号 Index NO.	代 号 Par NO.	名 称 Name	数量 Q'ty
1	12ZB-23-01000	箱盖 Cover	1
2	01010-51235	螺栓 M12×35 Bolt	2
3	12ZB-23-00001	橡胶垫 Washer	1
4	12ZB-23-00002	橡胶垫 Washer	1
5	01580-31008	螺母 M10 Nut	4
6	01643-31032	垫圈 10 Washer	4
7	12ZB-23-02000	箱体 Housing	1
8	01643-31232	垫圈 12 Washer	2
9	01580-31210	螺母 M12 Nut	2
10	01010-51030	螺栓 M10×30 Bolt	4



第 309 图 右踏板

FIG.309 RIGHT FOOTPLATE

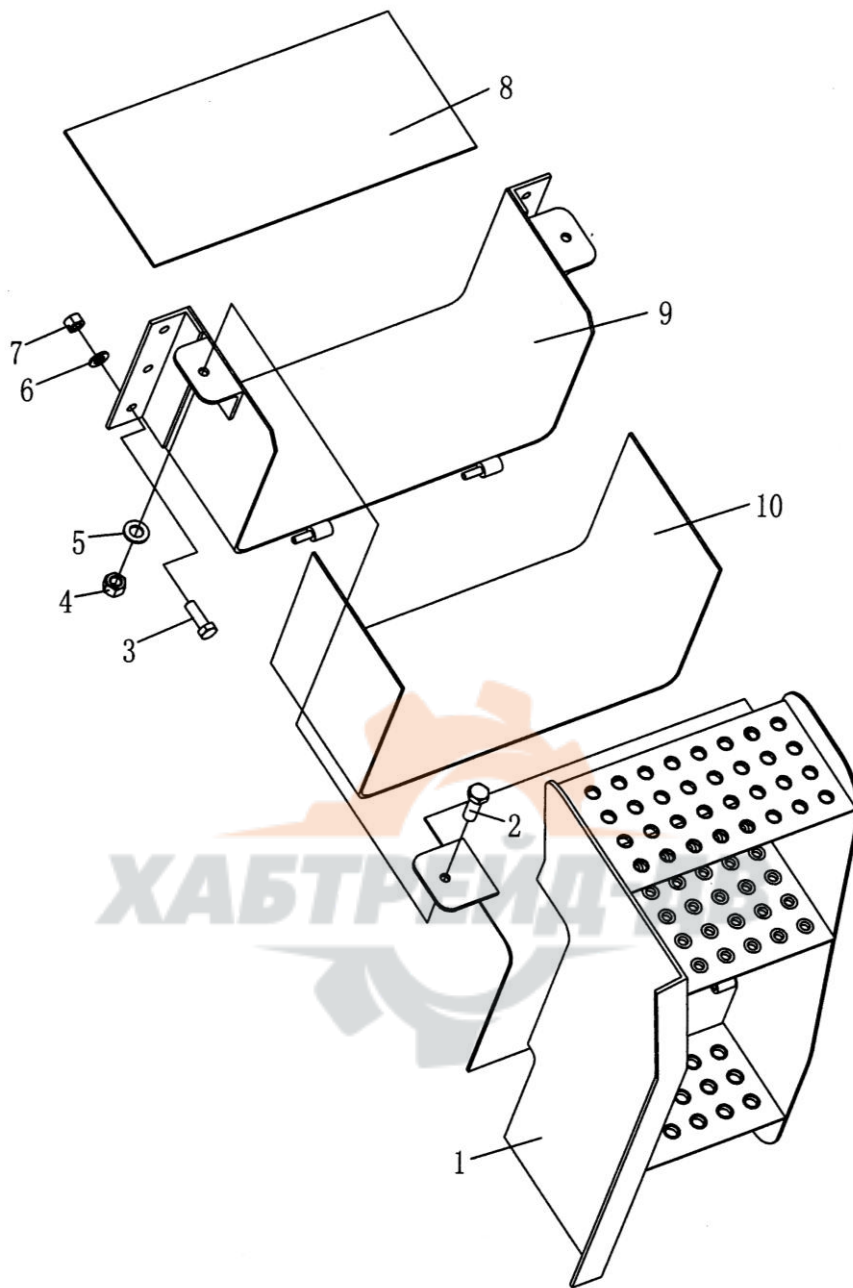

右踏板

RIGHT FOOTPLATE

序号 Index NO.	代 号 Par NO.	名 称 Name	数量 Q'ty
1	12ZB-24-01000	箱盖 Cover	1
2	01010-51235	螺栓 M12×35 Bolt	2
3	01010-51030	螺栓 M10×30 Bolt	4
4	01580-31210	螺母 M12 Nut	2
5	01643-31232	垫圈 12 Washer	2
6	01643-31032	垫圈 10 Washer	4
7	01580-31008	螺母 10 Nut	4
8	12ZB-23-00001	橡胶垫 Washer	1
9	12ZB-24-02000	箱体 Housing	1
10	12ZB-23-00002	橡胶垫 Washer	1



传动部件

DRIVER ASSEMBLY



第 201 图 传动系统

FIG.201 TRANSMISSION SYSTEM

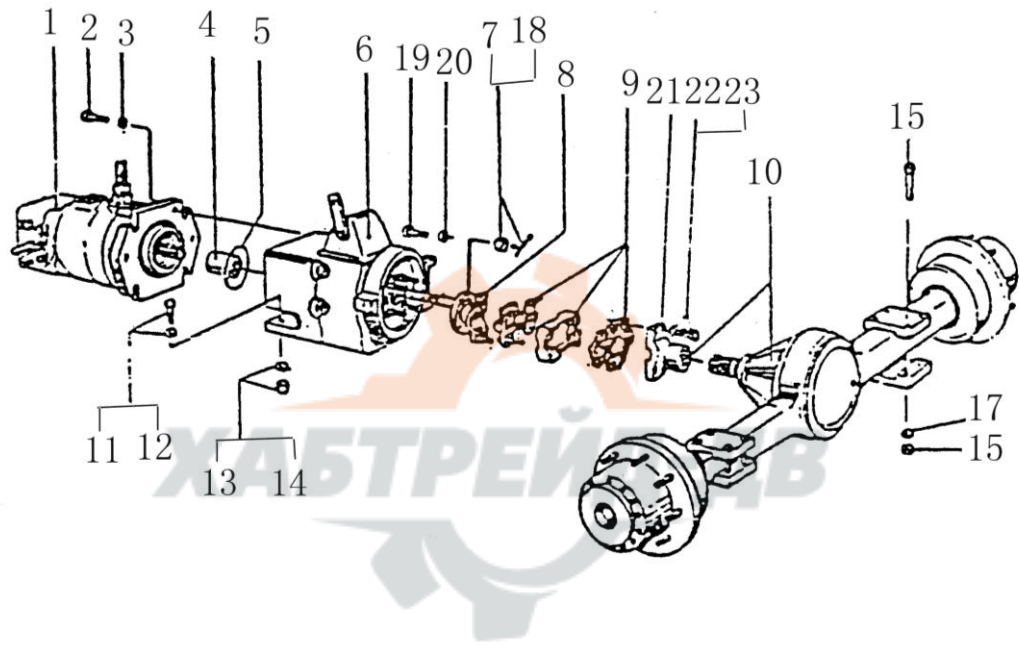

传动系统

TRANSMISSION SYSTEM

序号 Index NO.	代 号 Par NO.	名 称 Name	数量 Q'ty
1	12ZB-05-07000	驱动马达 Hydr motor	1
2	01010-51245	螺栓 M12*45 Bolt	4
3	01602-51236	垫圈 12 Washer	4
4	12Z-14-00008	花键套 Splined sleeve	1
5	07000-12125	O 型圈 D125*3.1 O-ring	1
6	12Z-14-00000	三速变速箱总成 Three-speed gear box	1
7	01582-01008	螺母 M10 Nut	4
8	12Z-14-00010B	联接法兰 Connecting flange	1
9	12ZB-04-00000	万向节总成 Universal joint	1
10	12ZB-03-01000	驱动桥总成 Wheel axle	1
11	01010-31680	螺栓 M16*80 Bolt	4
12	01602-21648	垫圈 16 Spring washer	4
13	01641-21626	垫圈 16 Washer	4
14	01582-01613	螺母 M16 Nut	4
15	12ZB-03-00003	螺栓 Bolt	8
16	GB6171-86	螺母 M24*2 Nut	8
17	01602-12472	垫圈 24 Spring washer	8
18	04050-12526	销 2.5*55 Pin	4
19	01010-31055	螺栓 M10*55 Bolt	4
20	01602-11030	垫圈 10 Washer	4
21	12ZB-03-00010	联接盘总成 Connecting flange	1
22	01602-51030	垫圈 10 Spring washer	8
23	01016-31030	螺栓 M10*30 Bolt	8

第 202 图 驱动桥

FIG.202 DRIVE BRIDGE

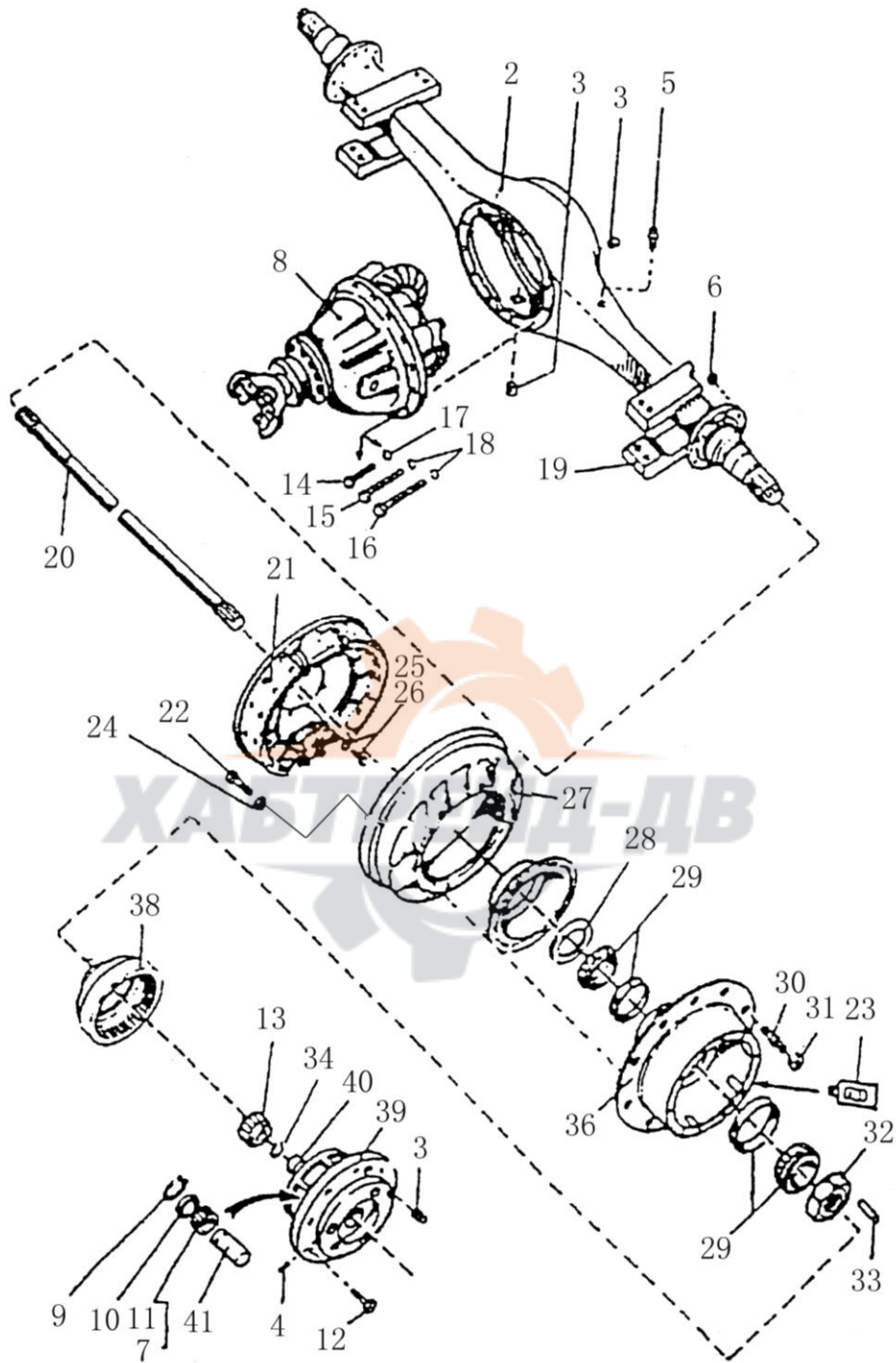

驱动桥

序号 Index NO.	代 号 Par NO.	名 称 Name	数量 Q'ty
1		驱动桥 Drive bridge	1
2		桥体 Drive bridge	1
3		加油螺塞 ZG3/4 Filling plug	4
4	GB78-76	螺钉 M8*12 Stop screw	6
5		排气阀 Discharge valve	1
6	GB52-76	螺母 M14 Nut	16
7	ZBH46001-87	轴承 JH-4035 Bearing	6
8		主减速器 Main speed reducer	1
9	GB894-76	拦圈 40 Retainer ring	6
10		挡圈 40 Retainer ring	6
11		行星轮 Planet gear	6
12	GB30-70	螺栓 M12 Bolt	32
13		太阳轮 Sun gear	2
14	GB21-76	螺栓 M12*35 Bolt	12
15	GB21-76	螺栓 M10*35 Bolt	2
16	GB21-76	螺栓 M10*55 Bolt	2
17	GB97-76	垫圈 12 Washer	12
18	GB97-76	垫圈 10 Washer	4
19		托块 Support or plate	2
20		传动轴 Shaft	2
21	NJ130-3502040/3502140	制动器 Break	2
22	GB52-76	螺栓 M16*40 Bolt	2
23		密封胶 Seal gum	按需
24	GB97-76	垫圈 16 Washer	20
25	GB848-76	垫圈 14 Washer	16
26	GB21-76	螺母 M14 Nut	16
27	01.4.1.2-1	制动鼓 Break drum	2
28	HG4-602-67	油封 PG100*140*12 Oil seal	4
29	GB297-64	轴承 2007117 Bearing	16
30		轮辋螺栓 Wheel bolt	16
31		轮辋螺母 Wheel nut	2
32		销紧螺母 lock nut	1

DRIVE BRIDGE

驱动桥

DRIVE BRIDGE

序号 Index NO.	代 号 Par NO.	名 称 Name	数量 Q'ty
33	GB297-64	销 6*22 Pin	2
34		弹性挡圈 Critic	2
35		轮毂 Hub	2
36		内齿轮 Internal gear	2
37		行星架 Planet carrier	2
38		止推块 Thrust block	2
39		行星轴 Shaft	6



第 203 图 制动器

FIG.203 BRAKE

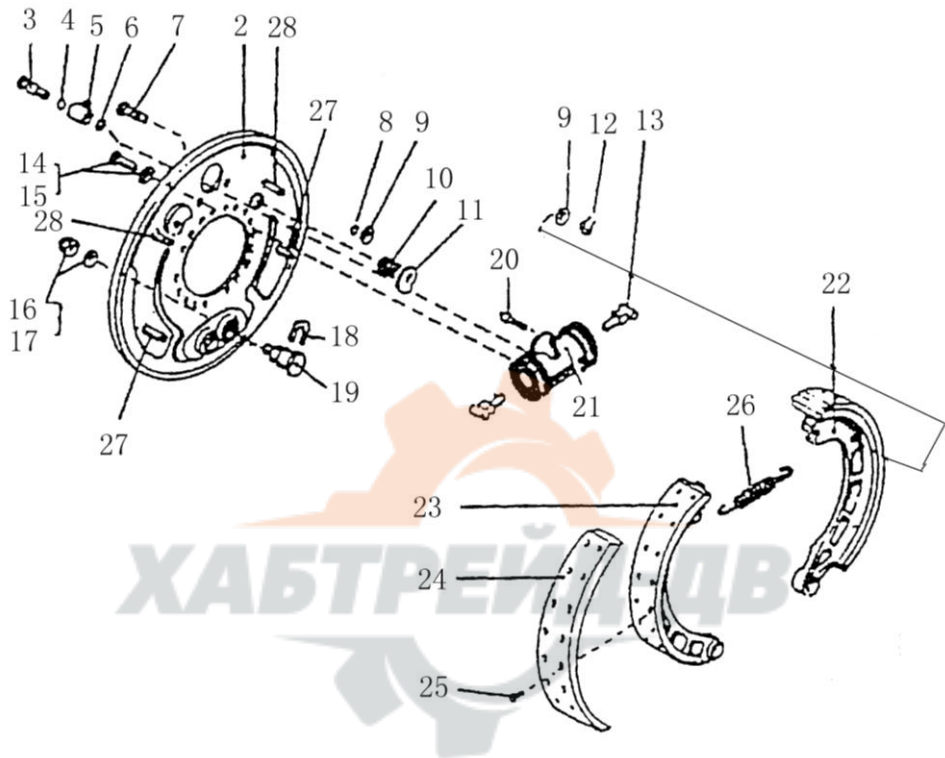

制动器

BRAKE

序号 Index NO.	代 号 Par NO.	名 称 Name	数量 Q'ty
1	NJ30-3502040/3502140	制动器 Brake	2
2		制动盘总成 Brake disc assembly	2
3		螺套 Bush	2
4		垫圈 Washer	2
5		进油接头 Oil inlet	2
6		垫圈 Washer	2
7		凸轮固定销 Pin	4
8	GB96-76	垫圈 12 Washer	4
9	GB96-76	垫圈 18 Washer	16
10		弹簧 Spring	
11		凸轮 Cam	4
12		挡环 Retainer ring	4
13		推杆 Handspike	8
14	GB21-76	螺栓 M10*20 Bolt	4
15	GB848-76	垫圈 10 Washer	4
16	GB52-76	螺母 M20*1.5 Nut	4
17	GB93-76	垫圈 20 Washer	4
18		挡圈 Washer	4
19		偏心轴 Centric shaft	4
20		回油接头 Joint	2
21		制动分泵 Brake pump	2
22		制动蹄总成 Brake shoe assembly	4
23		制动蹄 Brake shoe	4
24		摩擦带 Belt	4
25	GB875-76	铆钉 4*12 Rivet	72
26		复位弹簧 Spring	2
27		制动蹄支销 Pin	4
28		制动蹄支销 Pin	4

第 204 图 主减速器

FIG.204 MAIN SPEED REDUCER

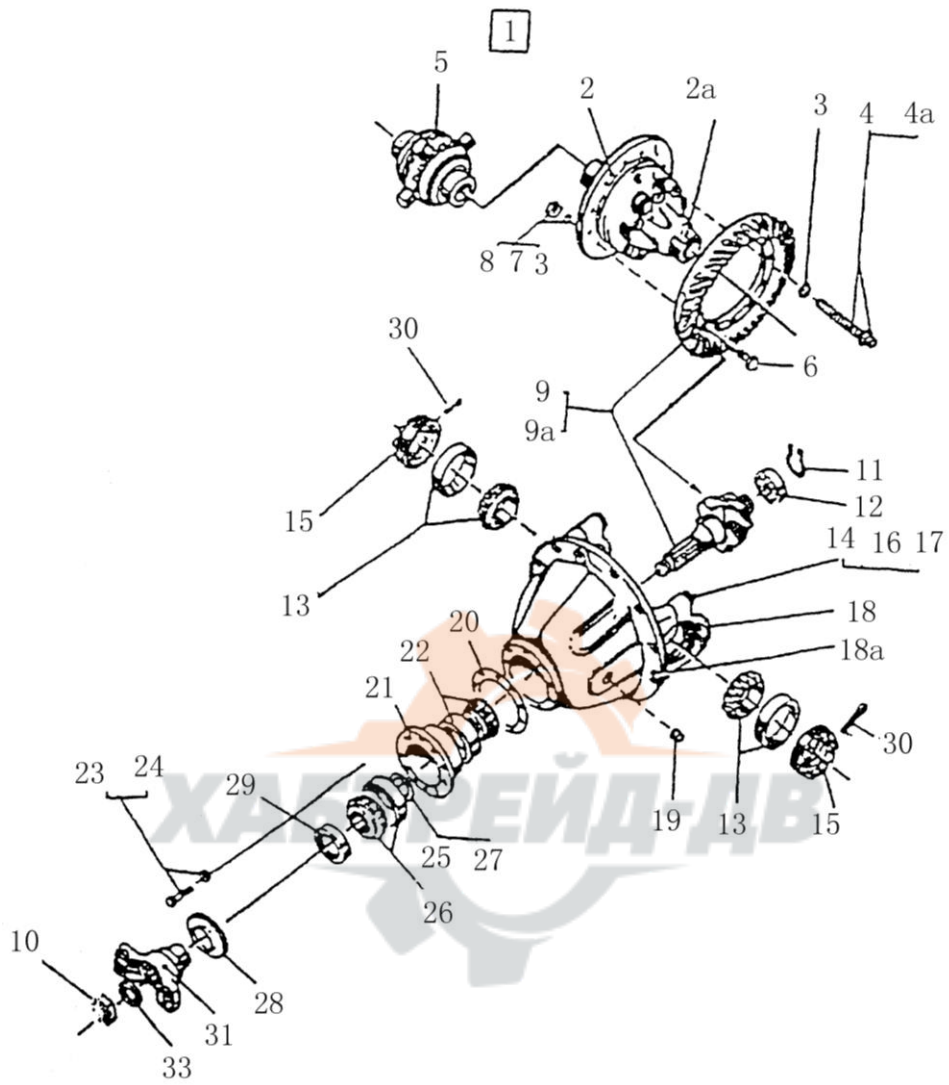

主减速器

MAIN SPEED REDUCER

序号 Index NO.	代 号 Par NO.	名 称 Name	数量 Q'ty
1		主减速器 Main speed reducer	1
2		差速器(左) Differential case	1
2a		差速器(右) Differential case	1
3	GB848-76	垫圈 12 Washer	20
4	GB52-76	螺栓 M12*80 Bolt	8
4a	GB343-82	钢丝 ϕ 1.8*300 Steel wire	4
5		差速器 Differential case	1
6	GB30-76	螺钉 M12*1.5*40 Screw	12
7		止动垫圈 Stop washer	6
8	GB52-76	螺母 M12*1.5 Nut	12
9		主动齿轮 Drive gear	1
10		螺母 Nut	1
11	GB894-76	挡圈 25 Snap ring	1
12		轴承 102305 Bearing	1
13		轴承 7813 Bearing	1
14	GB32-76	螺栓 M16*85 Bolt	4
15		调整螺母 Adjusting nut	2
16	GB97-76	垫圈 16 Washer	4
17	GB343-76	钢丝 ϕ 1.8*350 Steel wire	2
18		轴承盖 Cover	2
18a		轴承座 Bearing housing	1
19		磁性螺塞 Filling plug	1
20		调整垫 Shim	1
21		轴承座体 Bearing housing	1
22	GB298-64	轴承 27709 Bearing	1
23	GB30-76	螺栓 M10*40 Bolt	8
24	GB93-76	垫圈 10 Washer	8
25		调整垫 Shim	8
26	GB298-64	轴承 27308 Bearing	1 组
27		调整垫 Shim	1
28		后罩壳 Cover	1
29	HG4-692-69	油封 SG55*82*12.7 Seal ring	1
30		开口销 Cotter pin	2
31		法兰 Connecting flange	1
32		调整垫 Shim	1

第 205 图 手刹车装置

FIG.205 HAND BRAKE

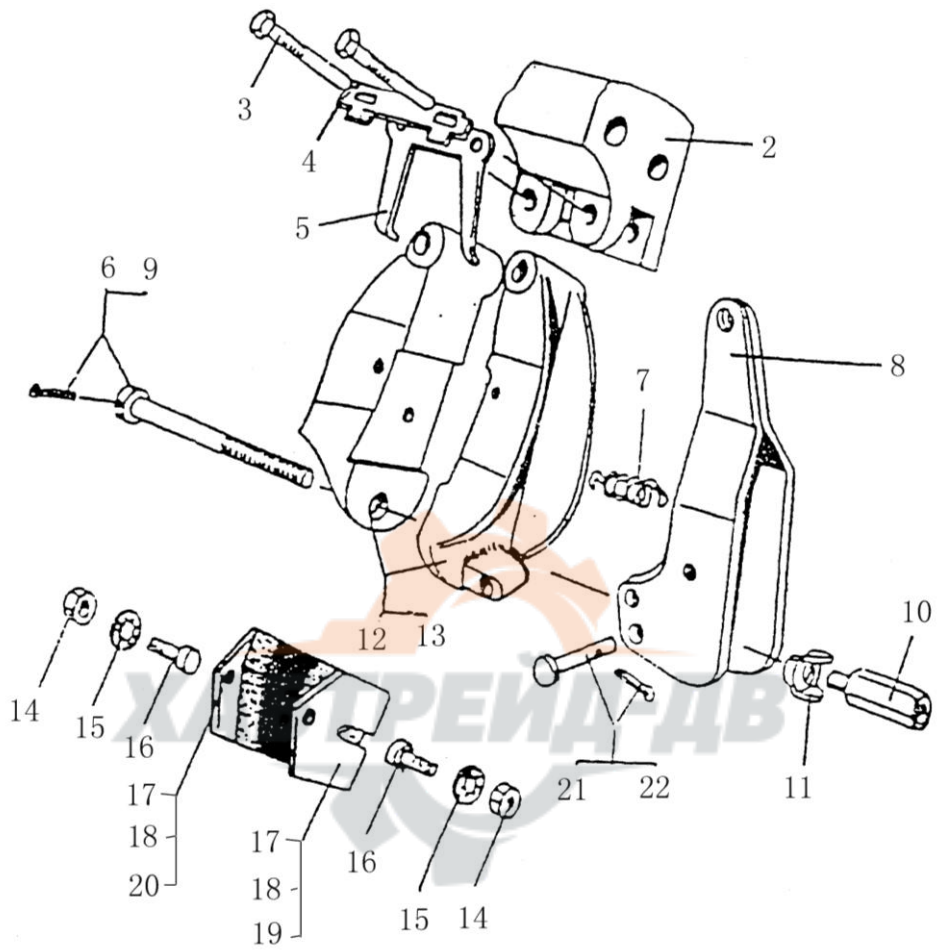

手刹车装置
HAND BRAKE

序号 Index NO.	代 号 Par NO.	名 称 Name	数量 Q'ty
1	12Z-14-02000	刹车装置 Disc brake equipment	1
2	12Z-14-02017	支架 Bracket	1
3	12Z-14-02018	螺钉 Screw	2
4	12Z-14-02019	压板 Lock plate	1
5	12Z-14-02020	叉 Fork	1
6	12Z-14-02015	销钉 Pin	1
7	12Z-14-02014	弹簧 Spring	1
8	12Z-14-02016	控制杆 Control lever	1
9	04050-02040	销 2*40 Pin	1
10	12Z-14-02011	连接螺母 Link Nut	1
11	12Z-14-02012	连接套 Link sleeve	1
12	12Z-14-02002	刹车板(左) Brake shoe	1
13	12Z-14-02007	刹车板(右) Brake shoe	1
14	01580-00504	螺母 M5 Nut	2
15	GB856-88	垫圈 5 Washer	2
16	12Z-14-02002	螺钉 Screw	2
17	12Z-14-02006	垫板 Washer	2
18	GB869-76	铆钉 Rivet	6
19	12Z-14-02005	刹车块(右) Brake lining	1
20	12Z-14-02003	刹车块(左) Brake lining	1
21	04050-02016	销 2*16 Pin	1
22	12Z-14-02010	销钉 Pivot	1

第 206 图 三速变速箱总成

FIG.206 THREE-SPEED GEAR BOX

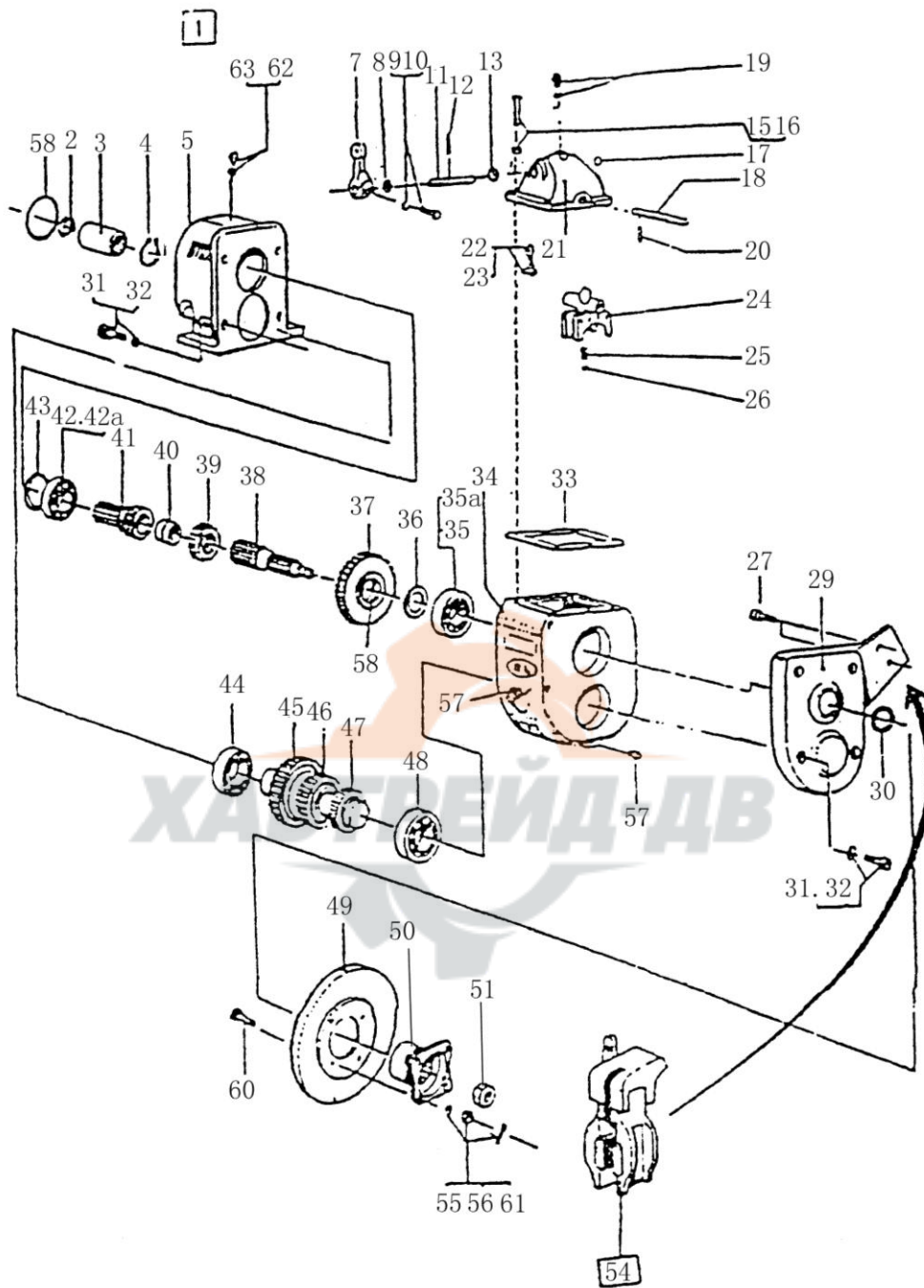

三速变速箱总成

THREE-SPEED GEAR BOX

序号 Index NO.	代 号 Par NO.	名 称 Name		数量 Q'ty
1	12Z-14-00000	三速变速箱总成	Three-speed gear box	1
2	04065-03212	挡圈 32	Retainer ring	1
3	12Z-14-00020	花键套	Splined sleeve	1
4	04064-06020	挡环 60	Retainer ring	1
5	12Z-01-00021	壳体	Housing	1
7	12Z-14-01012	拨叉操纵柄	Control lever	1
8	HG4-692-67	油封 PD18*30*10	Oil seal	1
9	01016-31022	螺栓 M10*22	Bolt	1
10	01602-01030	垫圈 10	Spring	1
11	12Z-14-01007	轴	Shaft	1
12	04025-00635	弹性销 6*35	Spring pin	1
13	12Z-14-01009	垫圈	Shin	3
15	01010-30818	螺栓 M8*18	Bolt	8
16	01602-00825	垫圈 8	Spring washer	8
17	12Z-14-01006	堵盖	Plug	3
18	12Z-14-01001	拨叉滑动轴	Slide shaft	1
19	07030-00252	通气塞	Valve rivet	1
20	04400-00636	铆钉 6*36	Rivet	1
21	12Z-14-01004	顶盖	Cover	1
22	12Z-14-01001	钢套	Sleeve	1
23	12Z-14-01010	销	Pin	1
24	12Z-14-01011	操纵杆	Fork	1
25	12Z-14-01005	弹簧	Spring	1
26	04260-00952	钢球 ϕ 9.5	Ball	1
27	01252-31235	螺钉 M12*35	Screw	2
29	12Z-14-00011	盖板	Cover	1
30	HG4-692-67	油封 PG55*75*12	Oil seal	1
32	01602-21648	垫圈 16	Spring washer	8
31	01010-31680	螺栓 M16*80	Bolt	8

三速变速箱总成

THREE-SPEED GEAR BOX

序号 Index NO.	代 号 Par NO.	名 称 Name	数量 Q'ty
33	12Z-14-00022	密封垫 Gasket	1
34	12Z-14-00012	箱体 Housing	1
35	GB277-89	轴承 50309 Ball bearing	1
35a	GB305-89	弹性卡环 100 Stop ring	1
36	12Z-14-00013	隔离圈 Spacer	1
37	12Z-14-00015	大齿轮 Gear	1
38	12Z-14-00016	花键轴 Splined shaft	1
39	12Z-14-00017	变速齿轮 Gear	1
40		滚针轴承 64805 Needle bearing	1
41	12Z-14-00019	齿轮轴 Shaft with gear	1
42	GB277-89	轴承 50212 Ball bearing	1
42a	04064-06020	挡环 60 Stop ring	1
43	12Z-14-00018	垫片 Washer	1
44	GB276-86	轴承 307 Ball bearing	1
45	12Z-14-00002	大齿轮 Gear	1
46	12Z-14-00003	中齿轮 Gear	1
47	12Z-14-00004	齿轮轴 Gear shaft	1
48	GB276-86	轴承 308 Ball bearing	1
49	12Z-14-00009	制动盘 Break disc	1
50	12Z-14-00008	连接套 Flange	1
51	12Z-14-00004	螺母 Nut	1
54	12Z-14-02000	手刹车机构 Hand brake	1
55	01592-01012	螺母 M10 Nut	4
56	01602-01030	垫圈 10 Washer	4
57	07042-20415	油塞 Plug	2
58	07000-02130	O 型圈 O-ring	1
60	01092-51040	螺栓 M10*1.25*40 Bolt	4
61	04050-02018	销 2*18 Pin	4

第 207 图 变速操纵系统

FIG.207 SPEED CONTROL SYSTEM

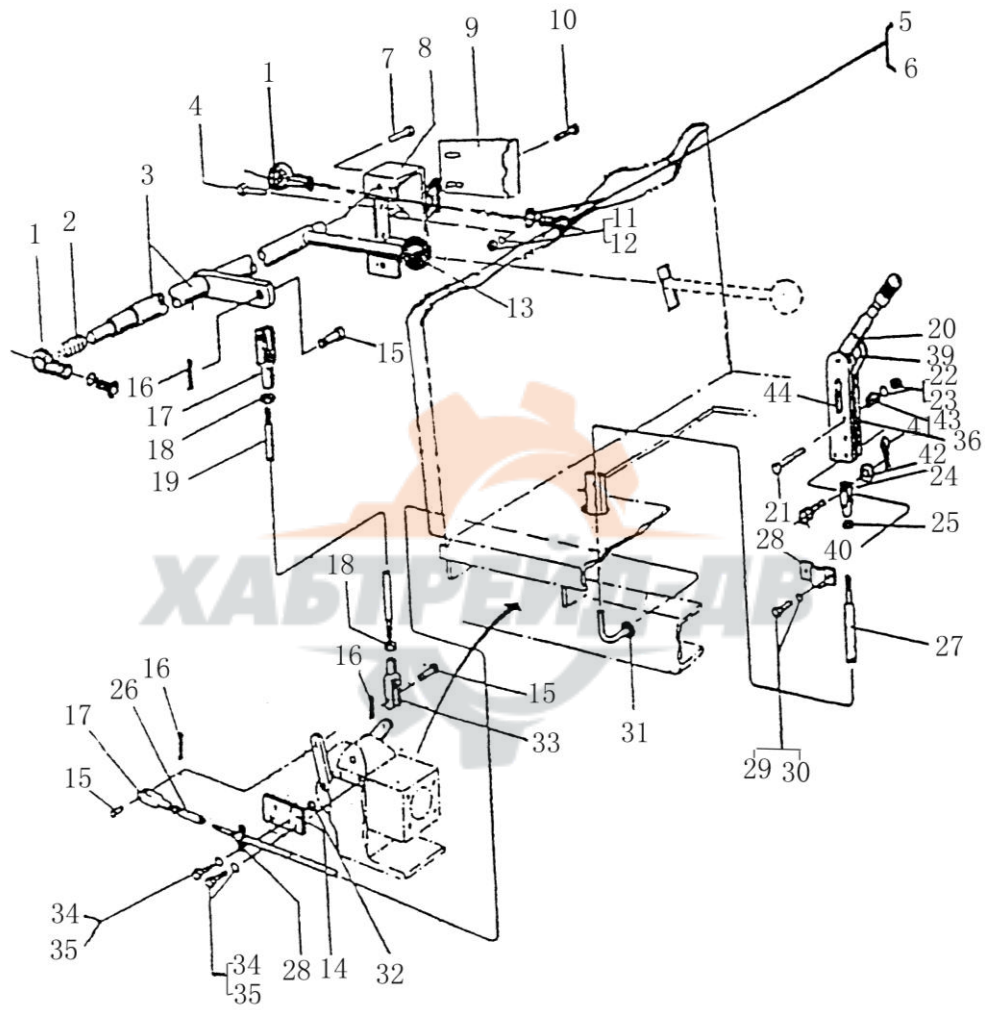

变速操纵系统

SPEED CONTROL SYSTEM

序号 Index NO.	代 号 Par NO.	名 称 Name	数量 Q'ty
1	04250-51683	关节轴承 Bearing	2
2	12ZB-21-00007	弹簧 Spring	1
3	12ZB-21-10000	连杆臂 Lind arm	1
5	01016-31635	螺栓 M16*35 Bolt	2
6	01643-11660	垫圈 16 Washer	2
7	01016-30816	螺栓 M8*16 Bolt	2
8	12ZB-21-20000	定位块 Bracket	1
9	12ZB-21-00005	挡板 Bracket	1
10	01016-30816	螺栓 M8*16 Bolt	2
11	01643-40823	垫圈 8 Washer	2
12	01580-10806	螺母 M8 Nut	2
13	12ZB-21-00008	手球柄 M16*50 Handle ball	1
14	12ZB-16-00011	板 Clamp	1
15	04205-11026	销轴 10*26 Pivot	2
16	04050-13220	开口销 3.2*20 Cotter pin	2
17	12ZB-16-00012	长叉口板 Fork	1
18	GB6170	六角螺母 M10(左) Nut	2
19	12ZB-21-00002	杆 Handle	1
20		手柄 Handle	1
21	01016-31055	螺栓 M10*55 Bolt	2
22	01643-31032	垫圈 10 Washer	5
23	01580-01008	螺母 M10 Nut	2
24	12ZB-16-00007	短叉口板 Fork link	1
25	01580-10806	螺母 M8 Nut	2
27	12ZB-16-00013	软轴总成 Brake cable	1
28	12ZB-16-00014	压板 Clamp	2
29	01016-30816	螺栓 M8*16 Bolt	2

变速操纵系统

SPEED CONTROL SYSTEM

序号 Index NO.	代 号 Par NO.	名 称 Name	数量 Q'ty
30	01643-40823	垫圈 8 Washer	4
32	01580-10806	螺母 M8 Nut	1
33	12ZB-21-00004	连杆叉(左旋) Fork	1
34	01643-30823	垫圈 8 Washer	4
35	01016-50825	螺栓 M8*25 Bolt	4
36	12ZB-16-30000	支板 Support plate	1
39	12ZB-16-00004	推拉板 Link	1
40	12ZB-16-00006	销轴 Pivot	1
41	04050-13216	开口销 3.2*16 Cotter pin	2
42	01643-31032	垫圈 10 Washer	3
43	12ZB-16-00005	隔套 Sleeve	2
44	12ZB-16-00008	支板 Support plate	1

第 208 图 脚刹车总成

FIG.208 FOOT BRAKE

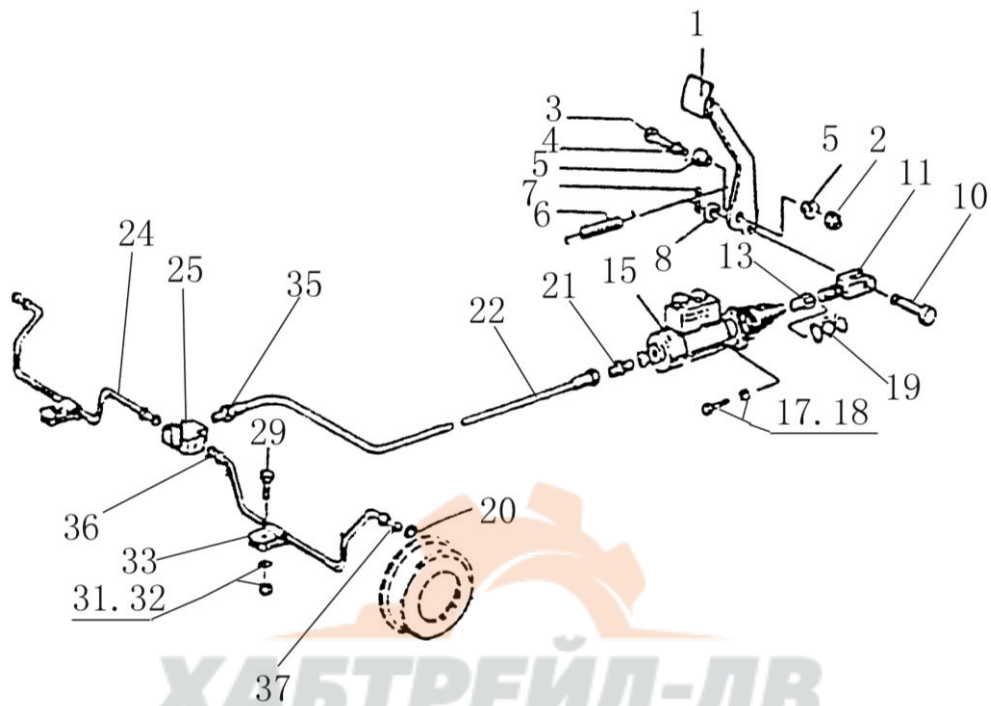

脚刹车总成
FOOT BRAKE

序号 Index NO.	代 号 Par NO.	名 称 Name	数量 Q'ty
1	12ZB-17-01000	脚踏板 Brake pedal	1
2	01590-11215	螺母 M12 Nut	1
3	01013-51225	螺栓 M12*125 Bolt	1
4	01640-21223	垫圈 12 Washer	2
5	12ZB-17-00002	衬套 Bushing	2
6	12ZB-17-00001	拉簧 Spring	1
7	04050-13020	开口销 3*20 Cotter pin	1
8	01643-31223	垫圈 12 Washer	2
10	04205-11235	销轴 A12*35 Pin	1
11	04210-21248	叉口板 Link	1
13	01582-11210	螺母 M12*1.5 Nut	1
15	12ZB-17-02000	制动泵总成 Brake pump	1
17	01643-30823	垫圈 8 Washer	3
18	01016-50825	螺栓 M8*25 Bolt	3
19	01643-31223	垫圈 12 Washer	3
20	JB982-77	垫圈 12 Washer	1
21	12ZB-17-00005	异径接头 Adapter	1
22	12ZB-17-05000	软管总成 Hose	1
24	12ZB-17-03000A	刹车支管 Hose	2
25	12ZB-17-04000	三通接头 Adapter	1
29	01016-50616	螺栓 M6*16 Bolt	2
31	01580-10605	螺母 M6 Nut	2
32	01602-20619	垫圈 6 Washer	2
33	08036-20614	线夹 Nip washer	2
36	12ZB-17-00007A	接头 1CT-12-02SP Adapter	2
37	18J-19-00002	管接头 Adapter	2

第 209 图 后轮总成

FIG.209 WHEELS ASSEMBLY

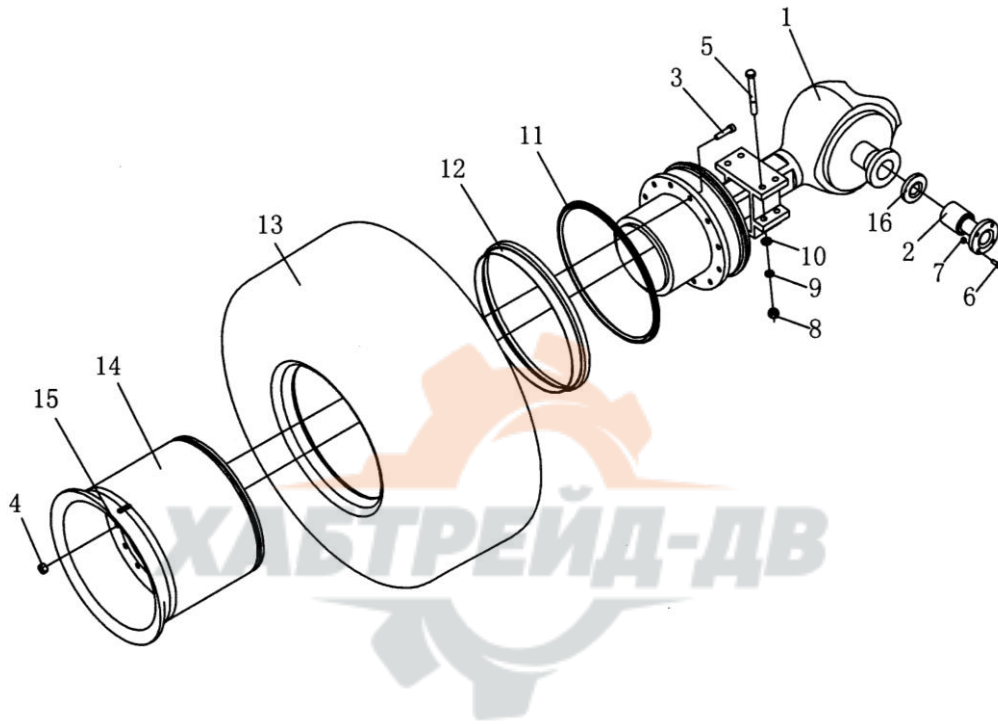

后轮总成

WHEELS ASSEMBLY

序号 Index NO.	代 号 Par NO.	名 称 Name	数量 Q'ty
1	12ZB-03-01000	驱动桥总成 Wheel axle	1
2	12ZB-03-00010	联接盘总成 Flange	1
3	12ZB-03-00001	铰制孔螺栓 Bolt	12
4	12ZB-03-00002	球面螺母 Nut	12
5	12ZB-03-00003	螺栓 Bolt	8
6	01010-31055	螺栓 M10×55 Bolt	4
7	SPL6177.1-2000	螺母 M10 Nut	4
8	GB6171-86	螺母 M24×2 Nut	8
9	01602-12472	弹簧垫圈 24 Washer	8
10	01643-32460	垫圈 24 Washer	16
11	12ZB-22-00002	锁环 Lock ring	2
12	12ZB-22-00003	内轮缘 Snap ring	2
13	12ZB-26-00000	轮胎总成 Tyre assembly	2
14	12ZB-22-00001	轮辋体 Rim	2
15	12ZB-22-00004	护罩 Shield	1
16	12ZB-03-00012	防护网 Dustproof cover	1

电气系统

ELECTRICAL SYSTEM



第 601 图 电器系统

FIG.601 ELECTRICAL SYSTEM

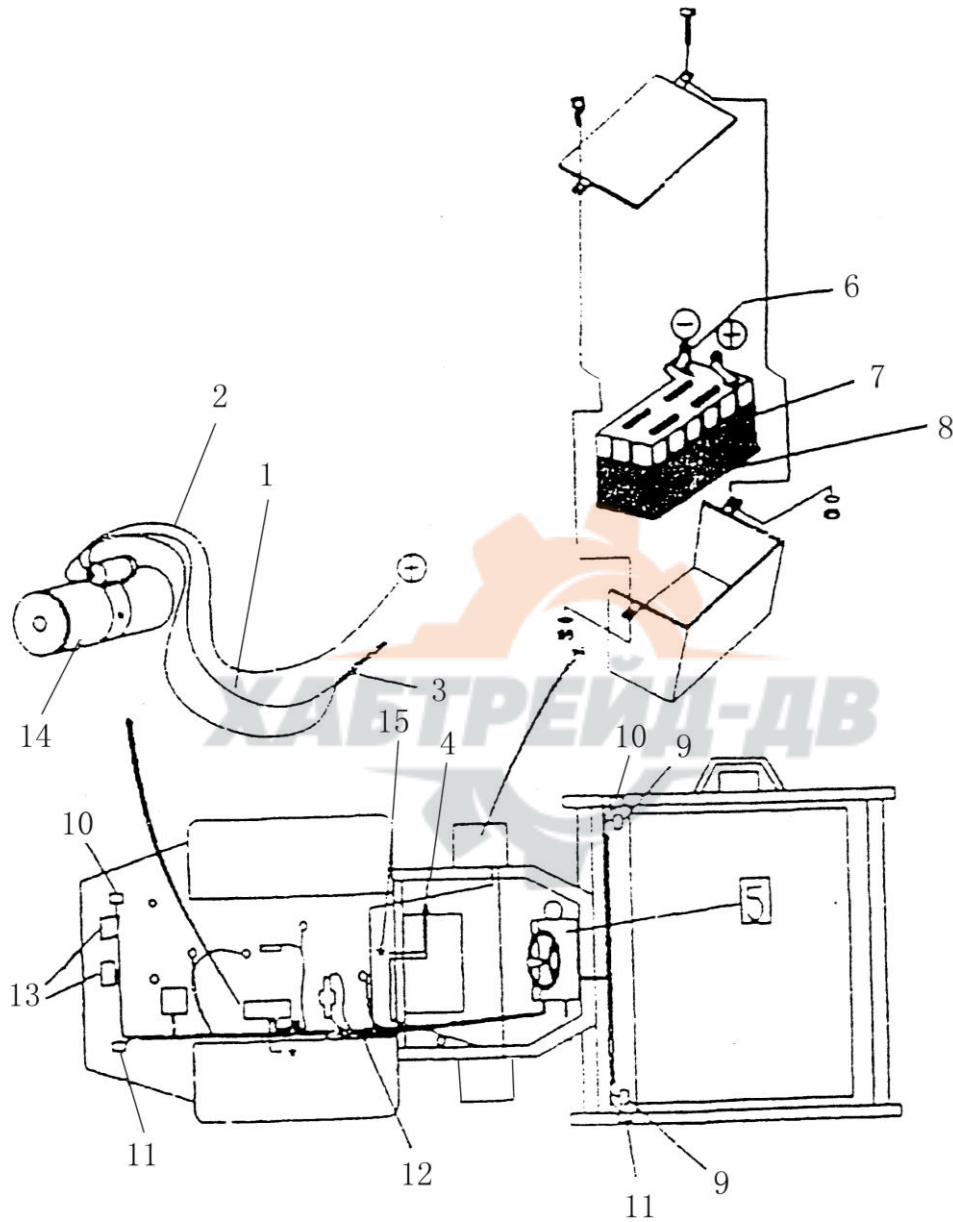

电器系统

ELECTRICAL SYSTEM

序号 Index NO.	代 号 Par NO.	名 称 Name	数量 Q'ty
1		起动导线 Staring cable	1
2		电瓶线 Coble	1
3		线束 Wire harness	1
4	16Z-18-04040	电源开关 Battery switch	1
5		仪表柜总成 Instruction case	1
6		接地线 Ground cable	1
7	12Z-18-03010	电瓶 Battery	2
8		橡胶垫 Rubber	2
9	16Z-08-10000	前大灯 Front lamp	2
10	16Z-19-05000	左转向灯 Turn-left lamp	1
11	16Z-19-05000	右转向灯 Turn-right lamp	1
12		线束 Wire harness	1
13	16Z-08-10000	后大灯 Back light	2
14	12ZB-18-04010	起动电机 Staring motor	1
15		接地线 Ground cable	1

第 602 图 仪表柜总成

FIG.602 INSTRUMENT CASE

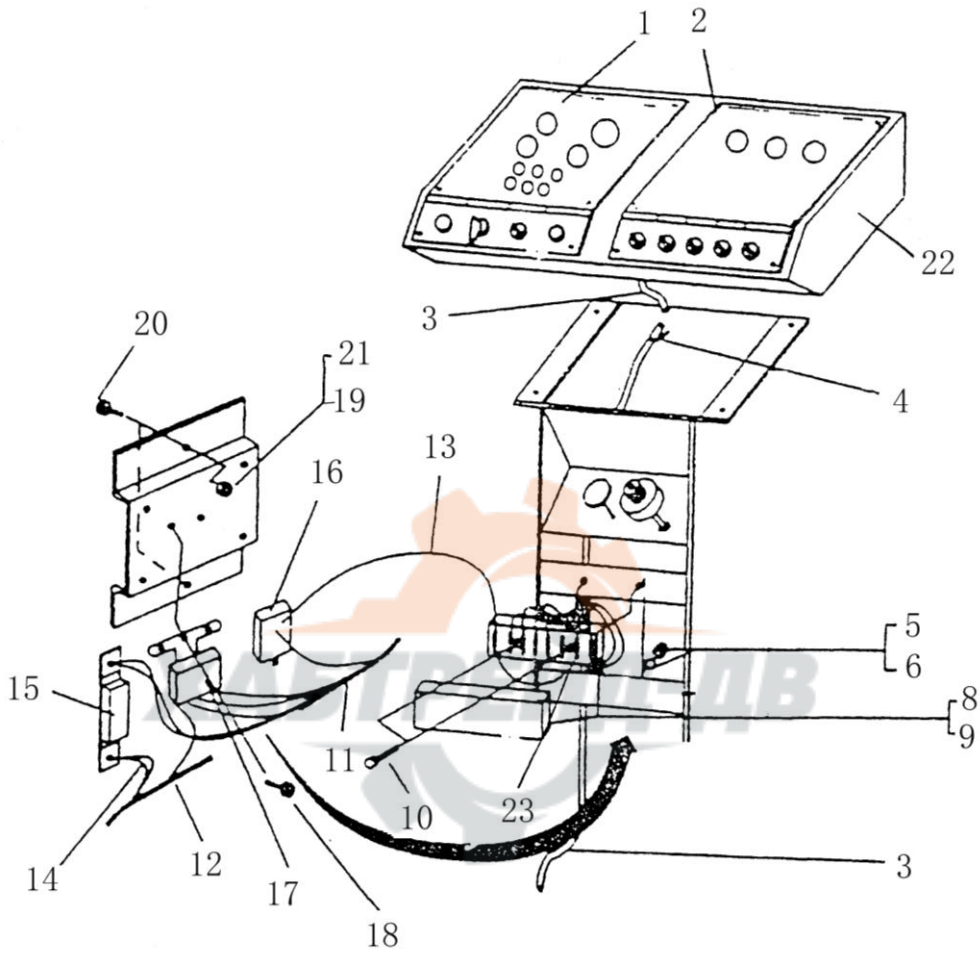

仪表柜总成

INSTRUMENT CASE

序号 Index NO.	代 号 Par NO.	名 称 Name	数量 Q'ty
1		左仪表板 Instrument board left	1
2		右仪表板 Instrument board right	1
3		线束 Wire harness	1
4		线扎 Fie	8
5	GB6170-86	螺母 M5 Nut	2
6	GB95-85	垫圈 5 Washer	2
7	BX508	连接板 Joint	1
8	BX308	保险盒 Fuse box	1
9	BX509	保险管 Fuse	8
10	GB67-85	螺钉 M5*10 Screw	2
11		线束 Wire harness	1
12		线束 Wire harness	1
13		线束 Wire harness	1
14		导线 Conductor	1
15	16Z-18-03040	延时继电器 Delay relay	1
16	16Z-18-03030	闪光器 Flash relay	1
17	16Z-18-03010	起动机继电器 Starting relay	1
18	GQ5781-86	螺栓 M6*25 Bolt	5
19	GB93-87	螺栓 M8*35 Bolt	2
20	GB5781-86	螺栓 M8*35 Bolt	2
21	GB41-86	螺母 M8 Nut	2
22		仪表盘总成 Instrument box	1
23	16Z-18-03020	振动继电器 Vibrations relay	1

第 603 图 仪表盘总成

FIG.603 INSTRUMENT BOX

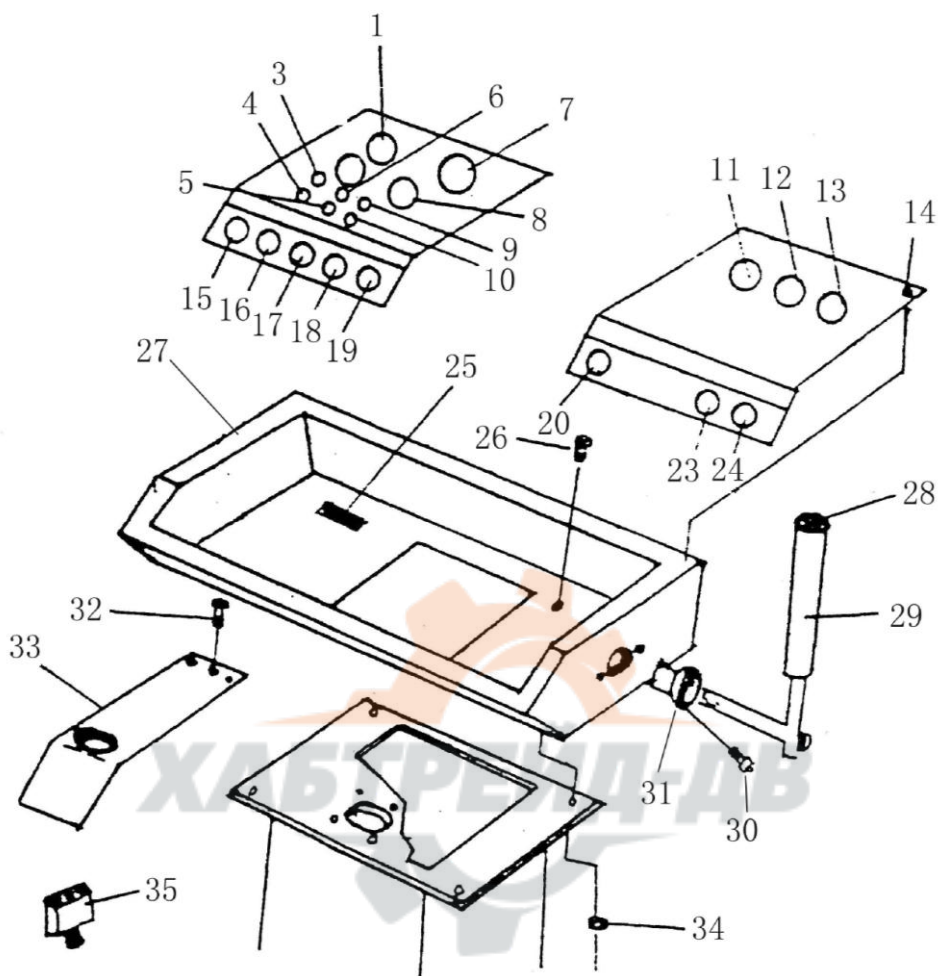

仪表盘总成

INSTRUMENT BOX

序号 Index NO.	代 号 Par NO.	名 称 Name	数量 Q'ty
1	16Z-18-03200	电压表 Volt meter	1
3	16Z-18-03140	机油压力指示灯 Oil-press lamp	1
4	16Z-18-03140	左转指示灯 Left lamp	1
5	16Z-18-03140	预热指示灯 Heating lamp	1
6	16Z-18-03140	手刹指示灯 Grip brake lamp	1
7	12ZB-18-03050	转速计时表 Watch	1
8	16Z-18-03170	液压油温表 Hy Oil temp	1
9	16Z-18-03140	充电指示灯 Change lamp	1
10	16Z-18-03140	右转指示灯 Right lamp	1
11	12ZB-18-03040	机油温度表 En Oil temp	1
12	12ZB-18-03030	机油压力表 Oil press	1
13	12ZB-18-03020	缸盖温度表 Jar cover temp meter	1
14	GB65-85	螺钉 M6*12 Screw	12
15	12ZB-18-03010	起动开关 Starter switch	1
16	16Z-18-03080	喇叭按钮 Horn button	1
17	16Z-18-03130	前大灯开关 Front light switch	1
18	16Z-18-03130	后大灯开关 Back light switch	1
19	16Z-18-03120	转向灯开关 Steering switch	1
20	16Z-18-03130	前雨刮器开关 On-off	1
23	16Z-18-03120	振幅选择开关 On-off	1
24	16Z-18-03130	电风扇开关 Fan On-off	1
25	12ZB-18-04070	预热控制器 Fuse	1
26	GB5781-86	螺栓 M8*20 Screw	4
27		仪表箱体 Box	1
28	16Z-18-03110	振动开关 Vibration switch	1
29		手柄 Handle	1
30		螺栓 M6*25 Screw	2
31		套 Bush	1
32	GB65-85	螺钉 M6*14 Bolt	11
33		空心架 Hollow box	1
34	GB889-86	螺母 M8 Nut	4
35	16Z-18-03090	中位开关 On-off	1

第 604 图 制冷系统（选装件）

FIG.604 COOL SYSTEM (OPTIONS)

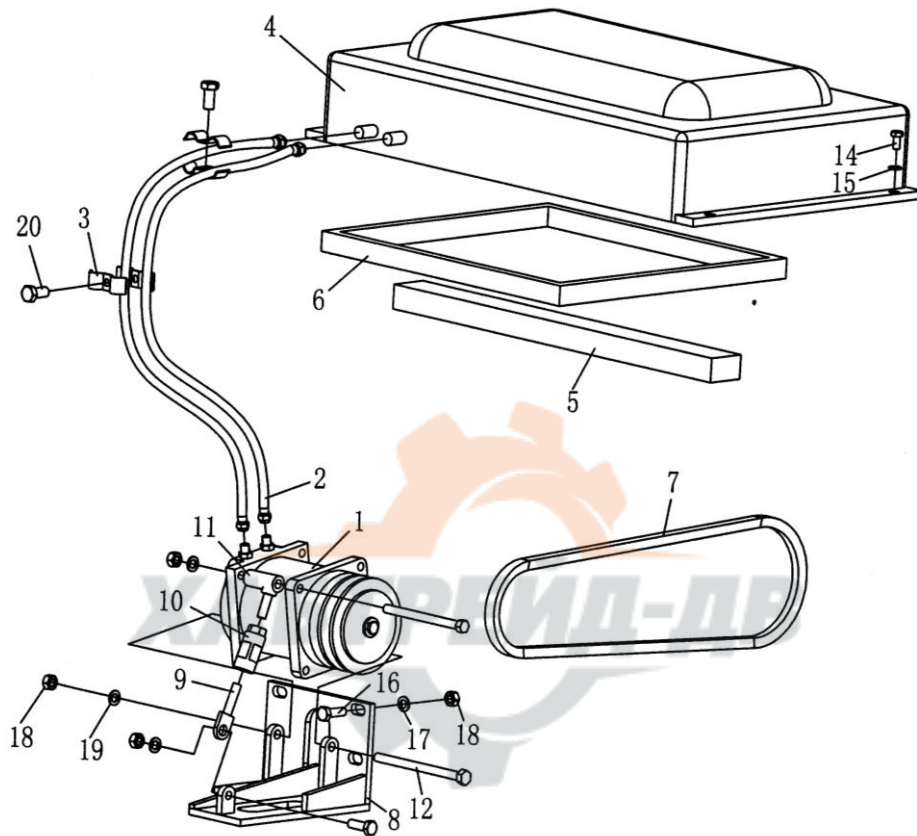

制冷系统（选装件）

COOL SYSTEM (OPTIONS)

序号 Index NO.	代 号 Par NO.	名 称 Name	数量 Q'ty
1	12ZB-25C-00001	压缩机 Compressor	1
2	12ZB-25C-00002	软管总成 Hose	1
3	08035-11510	夹箍 Hose clip	6
4	12ZB-25C-00004	顶置空调 Air-condition	1
5	12ZB-25C-00005	隔离板 Partition	1
6	12ZB-25C-00006	密封垫 Gasket	1
7	12ZB-25C-00007	皮带 Triangle cincture	1
8	12ZB-25C-01000	固定板 Plate	1
9	12ZB-25C-00008	压缩机锁紧轴 Shaft	1
10	12ZB-25C-02000	压缩机调整轴 Shaft	1
11	12ZB-25C-03000	压缩机固定管 Canal	1
12	16Z-10-00002	压缩机固定轴 Shaft	1
13	01220-40620	螺钉M6×20 Bolt	4
14	01010-50816	螺栓M8×16 Bolt	4
15	01641-20812	垫圈8 Washer	4
16	01010-51025	螺栓M10×25 Bolt	4
17	01641-21008	垫圈10 Washer	4
18	01580-01008	螺母M10 Nut	9
19	01602-51020	垫圈10 Washer	4
20	01010-51020	螺栓M10×20 Bolt	4