

LG938 轮式装载机 零部件图册

LG938 WHEEL LOADER PARTS CATALOG



山东临工工程机械有限公司

SHANDONG LINGONG CONSTRUCTION MACHINERY CO., LTD.



LG938 轮式装载机 零部件图册

880*1230mm 16 开本 8.25 印张
2006 年 9 月 第一版 第一次印刷

山东临工工程机械有限公司

地址：山东省临沂市经济开发区临工工业园

电话：0539-8785688

传真：0539-8785698 0539-8785671

技术服务：0539-8785800

网址：<http://www.sdlg.cn>

前言

LG938 型轮式装载机零部件图册，是为了便于用户在使用、维修和保养等工作中的方便而绘制的，以供在使用过程中查阅及参考，也可帮助用户了解本车的结构和装配关系。发动机另有专用的零部件图册，故本书未再绘出。

本图册按各总成及结构布局绘制出了各零部件的图形及相互装配关系。凡装机后不可拆卸的部件（焊接件、铆合件），一般只标出部件代号，不另列其组成零件，明细表采用中英文对照编排。

本图册按照配置为东风康明斯发动机、定轴式变速箱、钳盘式制动桥、先导操纵的现行产品编绘，同类机型可以此为参照。随着科技的进步和生产水平的提高，产品将会不断改进，故本图册的内容将会有部分与以后的产品不一致，如有变动恕不通知，因此，敬请用户在订购零部件时，指明所购整车的出厂日期和编号。

本图册由王兆勋任主编，参加编绘设计工作的主要有支开印等同志，在编绘过程中得到了有关部门和同志的大力支持，特此致谢。

编者

2006 年 9 月

FOREWORD

THIS PART LIST OF LG938 WHEEL LOADER IS INTENDED AS A CONSULTATION REFERENCE FOR THE USERS' USING THE MACHINE, AND TO HELP THEM REPAIR AND MAINTAIN THE LOADERS, IT CAN ALSO HELP THE USERS TO BE FAMILIAR WITH THE CONSTRUCTION AND ASSEMBLY RELATION OF THE MACHINE. THE ENGINE HAS ITS OWN PART LIST WITHIN. SO THIS BOOK DOES NOT CONTAIN THE ENGINE PART LIST.

THE PART LIST CONTAINS THE PART DRAWINGS OF DIFFERENT ASSEMBLIES, SHOWING THE SHAPE OF THE PARTS AS WELL AS THE ASSEMBLING RELATION. THE COMPONENTS WHICH CAN NOT BE TAKEN APART (LIKE THE WELDMENT OR RIVETED ASSEMBLIES) ARE INDICATED ONLY BY THEIR COMPONENT NUMBERS WITHOUT THE CONSISTING PART NUMBERS. THE NAME LIST SHOWS THE PART NUMBERS, PART NAMES, AS WELL AS QUANTITIES. ALTERATIONS IN DESIGN ARE NECESSARILY WITH THE TECHNICAL DEVELOPMENT, THEREFORE, SPECIFICATIONS ARE SUBJECT TO CHANGE WITHOUT NOTICE BEFORE THE LIST BEING REVISED, AND WHEN ORDERING SPARE PARTS. USERS ARE KINDLY REQUESTED TO INFORM THE MANUFACTURING DATE AND BATCH NUMBER OF THE WHEEL LOADER.

THE COMPILER

2006. 09

A. 发动机系统

A. DIESEL ENGINE SYSTEM

A1 发动机系统	(1)
A1 DIESEL ENGINE SYSTEM.....	(2)
A1 发动机系统	(3)
A1 DIESEL ENGINE SYSTEM.....	(4)
A2 油门操纵机构	(5)
A2 GOVERNOR CONTROL SYSTEM	(6)

B. 变速箱系统

B. TRANSMISSION SYSTEM

B1 变速箱系统.....	(7)
B1 TRANSMISSION SYSTEM	(8)
B2 变速器系统	(9)
B2 TRANSMISSION SYSTEM	(10)
B3 动力输入装置	(11)
B3 POWER IUTPUT.....	(12)
B4 动力输出装置	(13)
B4 POWER OUTPUT.....	(14)
B5 控制阀总成(I)	(15)
B5 CONTROL VALVE ASSEMBLY(I).....	(16)
B6 转速表.....	(17)
B6 SPEEDOMETER.....	(18)
B7 空转轮	(19)
B7 IDLE WHEEL.....	(20)
B8 离合器 151	(21)
B8 CLUTCH 151 KV+K1.....	(22)
B9 离合器 152	(23)
B9 CLUTCH 152 KR+K2.....	(24)
B10 离合器 153.....	(25)
B10 CLUTCH 153 K4+K3.....	(26)
B11 停车制动系统	(27)
B11 PARKING BRAKE ASS' Y.....	(28)
B12 变速压力阀.....	(29)
B12 PRESSURE VALVE.....	(30)
B13 加油管总成.....	(31)
B13 SUCTION PIPE ASS'Y.....	(32)
B14 油管、虑清器	(33)
B14 OIL PIPE、FILTER.....	(34)
B15 取力器.....	(35)
B15 POWER TAKE-OFF (P. T. O)	(36)
B16 控制阀总成(II)	(37)
B16 CONTROL VALVE ASSEMBLY(II).....	(38)

C. 驱动桥系统

C. AXLE SYSTEM

C1 驱动桥系统.....	(39)
---------------	------

C1 AXLE ASSEMBLY	(40)
C2 驱动桥总成.....	(41)
C2 AXLE ASSEMBLY.....	(42)
C3 前(后)主传动总成.....	(43)
C3 FRONT (REAR) AXLE MAINDRIVE ASS' Y	(44)
C4 轮边减速器总成	(45)
C4 FINAL DRIVE ASSEMBLY.....	(46)
C5 轮胎轮辋总成	(47)
C5 RIM AND TYRE ASSEMBLY	(48)
D. 工作装置液压系统	
D. IMPLEMENT HYDRAULIC SYSTEM	
D1 工作装置液压系统	(49)
D1 IMPLEMENT HYDRAULIC SYSTEM.....	(50)
D1 工作装置液压系统	(51)
D1 IMPLEMENT HYDRAULIC SYSTEM.....	(52)
D1 工作装置液压系统	(53)
D1 IMPLEMENT HYDRAULIC SYSTEM.....	(54)
D2 快换装置液压系统.....	(55)
D2 QUICK COUPLING EQUIPMENT HYDRAULIC SYSTEM.....	(56)
D3 转斗油缸	(57)
D3 DUMP CYLINDER	(58)
D4 动臂油缸	(59)
D4 LIFT ARM CYLINDER	(60)
D5 双联泵.....	(61)
D5 TANDEM GEAR PUMP	(62)
D6 先导阀总成.....	(63)
D6 PRIORITY VALVE.....	(64)
E. 油箱	
E. TANK	
E1 燃油箱总成	(65)
E1 FUEL TANK ASSEMBLY	(66)
E2 液压油箱总成.....	(67)
E2 HYDRAULIC TANK ASSEMBLY	(68)
F. 工作装置	
F. WORKING EQUIPMENT	
F1 工作装置	(69)
F1 WORKING EQUIPMENT	(70)
G. 转向系统	
G. STEERING SYSTEM	
G1 转向系统	(71)
G1 STEERING SYSTEM	(72)
G2 转向器总成	(73)
G2 STEERING GEAR	(74)
G3 优先阀总成.....	(75)
G3 PRIORITY VALVE.....	(76)

G4 转向油缸总成	(77)
G4 STEERING CYLINDER	(78)
H. 制动系统	
H. BRAKE SYSTEM	
H1 行车制动系统	(79)
H1 SERVICE BRAKE SYSTEM	(80)
H2 盘式制动器	(81)
H2 DISC BRAKE	(82)
H3 储气罐、制动阀、油水分离器	(83)
H3 AIR RESERVOIR、BRAKE CONTROL VALVE、AIR DRYER	(84)
H4 加力泵总成	(85)
H4 BRAKE BOOSTER	(86)
H5 驻车制动系统	(87)
H5 PARKING BRAKE SYSTEM	(88)
I. 车架	
I. FRAME	
I1 前车架总成	(89)
I1 FRONT FRAME	(90)
I2 后车架总成	(91)
I2 REAR FRAME	(92)
I3 配重铁总成	(93)
I3 COUNTER WEIGHT	(94)
J. 驾驶室	
J. CAB GROUP	
J1 驾驶室总成	(95)
J1 CAB GROUP	(96)
J2 仪表盘总成	(97)
J2 PANEL ASS' M	(98)
J3 座椅支架总成	(99)
J3 SEAT ASSEMBLY	(100)
K. 覆盖件系统	
K. COVER SYSTEM	
K1 发动机罩总成	(101)
K1 HOOD OF DIESEL ENGINE ASSEMBLY	(102)
K2 左台架总成	(103)
K2 LEFT BENCH GROUP	(104)
K3 右台架总成	(105)
K3 RIGHT BENCH GROUP	(106)
K4 左、右灯架	(107)
K4 LEFT RIGHT LAMP FRAM E	(108)
K5 左右前挡泥瓦	(109)
K5 LEFT RIGHT FRANT RENDER	(110)
K6 电瓶箱总成	(111)
K6 BATTERY CASE ASSEMBLY	(112)
L. 空调系统	

L. AIR CONDITIONER SYSTEM

L1 空调系统 (113)

L1 AIR CONDITIONER SYSTEM (114)

M. 电气系统

M. ELECTRIC SYSTEM

M1 电气系统 (115)

M1 ELECTRIC SYSTEM (116)



A 发动机系统

DIESEL ENGINE SYSTEM



山东临工工程机械有限公司
SHANDONG LINGONG CONSTRUCTION MACHINERY LTD.

A1

发动机系统

DIESEL ENGINE SYSTEM

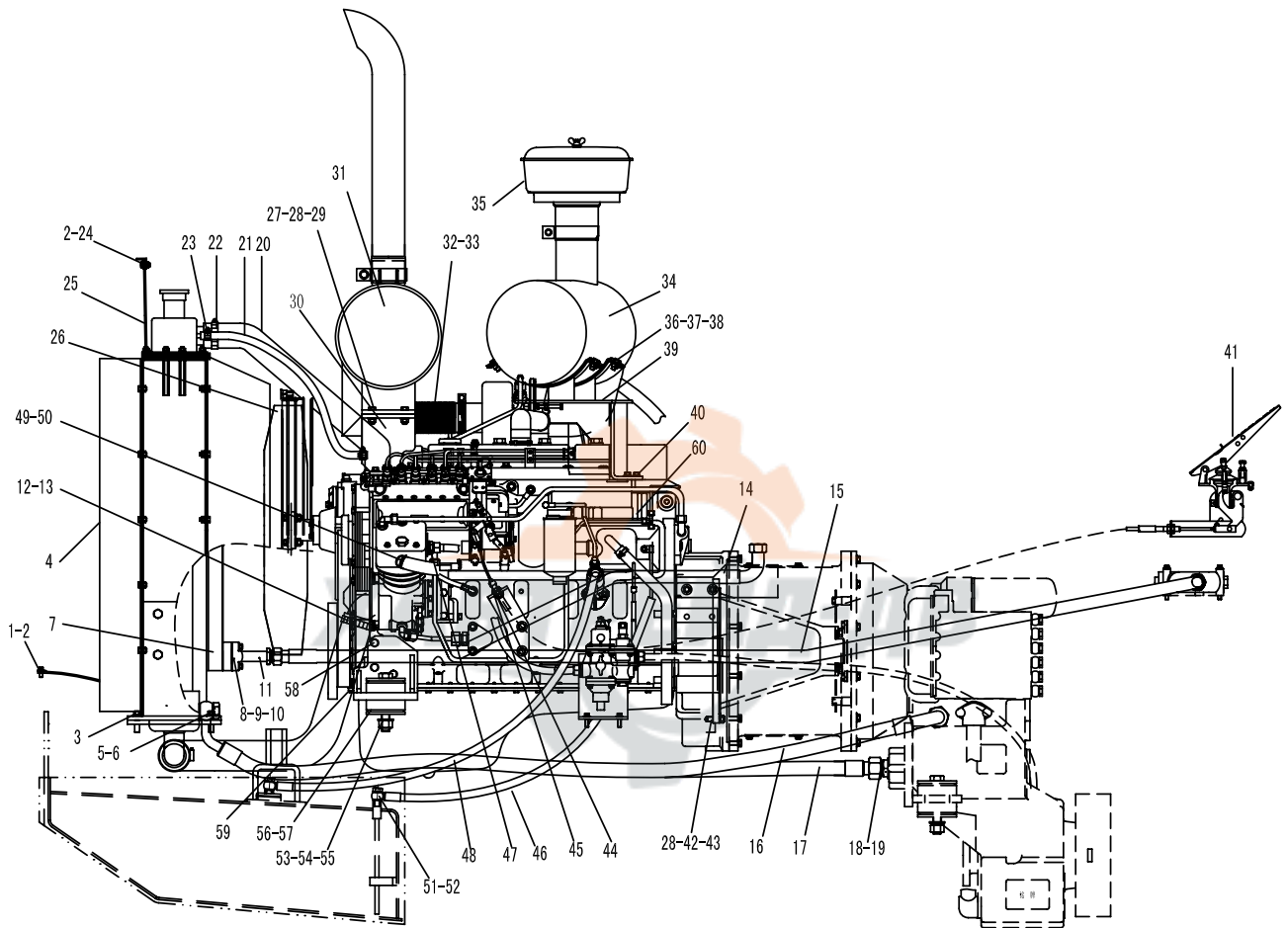

A1

序号	代号	名称		数量	备注
KEY	PART NO.	DESCRIPTION		QTY	REMARKS
1	2903000780	压板	PRESS PLATE	1	Q235A
2	4011000461	螺栓 GB16674-M8*16EpZn-8.8	BOLT GB16674-M8*16EpZn-8.8	8	
3	4011000091	螺栓 GB5783-M12*40EpZn-8.8	BOLT GB5783-M12*40EpZn-8.8	4	
4	4190000459	散热器	RADIATOR	1	部件
5	4011000399	螺栓 JB999-M24*1.5*50-35	BOLT JB999-M24*1.5*50-35	2	
6	4015000233	垫圈 JB1002-24-T2	WASHER JB1002-24-T2	4	
7	4120001061	油冷却器 B1342	OIL COOLER B1342	1	部件
8	4030000279	O形圈 GB3452.1-25*3.55G	O-RING GB3452.1-25*3.55G	2	
9	4011000475	螺栓 GB16674-M10*30EpZn-8.8	BOLT GB16674-M10*30EpZn-8.8	8	
10	4041000137	分体法兰 LGB117306400	FLANGE LGB117306400	2	
11	2903000781	过渡钢管	TRANSITION STEEL PIPE	2	部件
12	2903000789	发动机进水胶管	HOSE	1	耐油橡胶
13	4017000014	喉箍 JB8870-d80	CLAMP JB8870-d80	2	部件
14	4041000725	软管 LGB164012160	SOFT HOSE LGB164012160	1	
15	4041000713	软管 LGB165012250	SOFT HOSE LGB165012250	1	部件
16	2903000790	变矩器至冷却器油管	TO COOLER OIL PIPE	1	部件
17	2903000791	冷却器至变矩器油管	TO TORQUE CONVERTER OIL PIPE	1	部件
18	2903000793	接头体	CONNECTOR	2	35
19	4015000073	垫圈 JB1002-30-T2	WASHER JB1002-30-T2	2	
20	2903000784	发动机出水胶管	HOSE	1	耐油橡胶
21	4120000388	胶管 JB8406-B10*800	HOSE JB8406-B10*800	1	
22	4017000018	喉箍 JB8870-d70	CLAMP JB8870-d70	2	部件
23	4017000015	喉箍 JB8870-d25	CLAMP JB8870-d25	2	部件
24	2903000786	压板	PRESS PLATE	1	Q235A
25	2903000785	挡风橡胶板	RUBBER PLATE	1	工业胶板
26	4190000138	风扇 610	FAN 610/7-7/37.5/PAG/2ZR/25.4/4*10/BC60/AFAN	1	部件
27	4011000085	螺栓 GB5783-M10*35EpZn-8.8	BOLT GB5783-M10*35EpZn-8.8	4	
28	4013000007	螺母 G B6170-M10EpZn-8	NUT GB6170-M10EpZn-8	8	
29	4015000162	垫圈 GB97.1-10EpZn-300HV	WASHER GB97.1-10EpZn-300HV	8	
30	2901000935	消声器支架	FRAME	1	部件
31	4110000187	消声器 XH. G402X. W	DISSIPATIVE MUFFLER XH. G402X. W	1	部件
32	2901000936	波纹管	ACCORDION PIPE	1	部件
33	4110000192	V形抱箍 3903652	V-ANCHOR EAR 3903652	1	部件
34	4110000267	空气滤清器 A669	AIR FILLTER A669	1	部件
35	4110000181	盆式粗滤器 PC100-0000	FILLTER PC100-0000	1	部件
36	4011000102	螺栓 GB5783-M8*16EpZn-8.8	BOLT GB5783-M8*16EpZn-8.8	4	

A1

发动机系统

DIESEL ENGINE SYSTEM

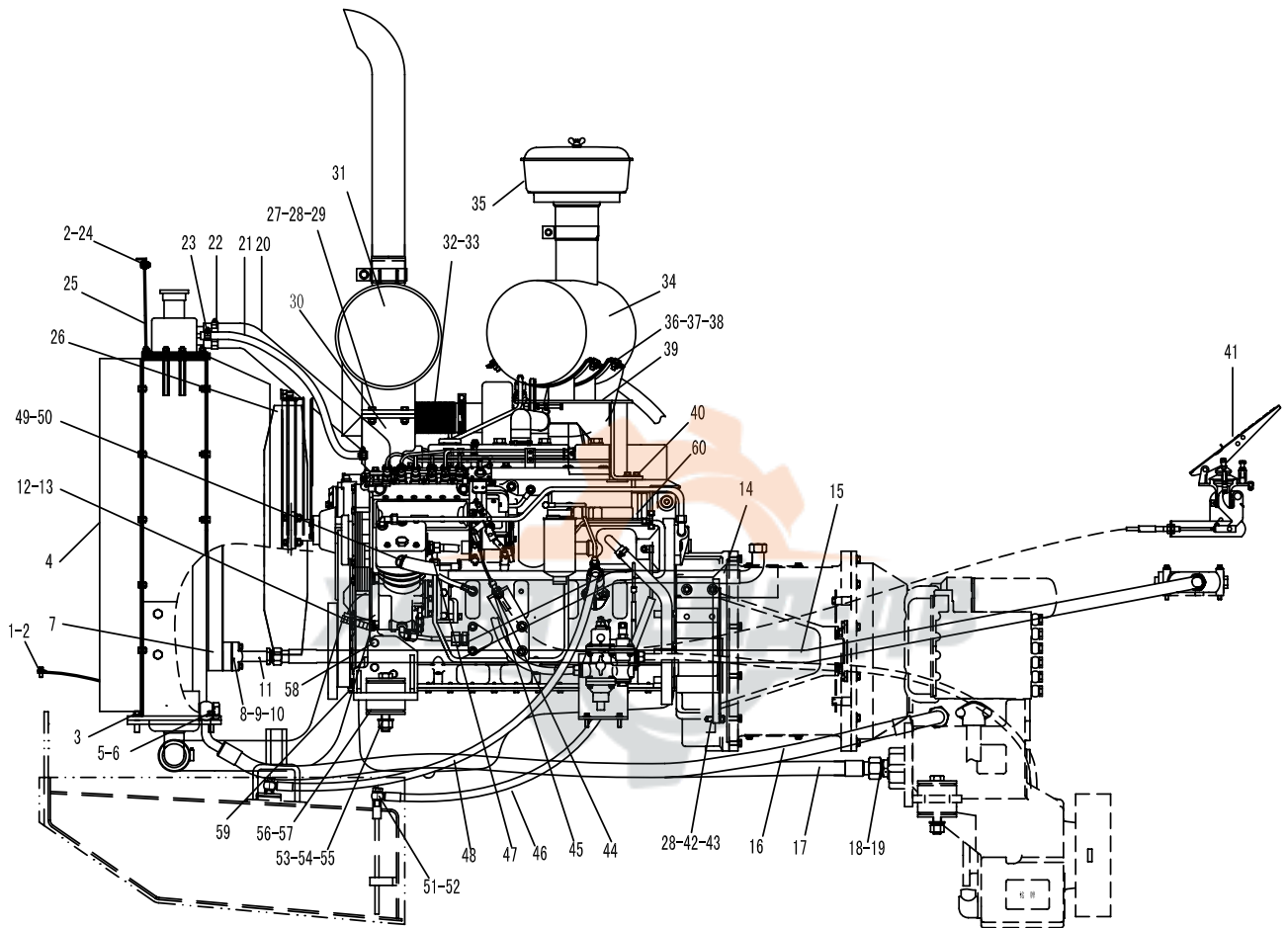

A1

序号	代号	名称		数量	备注
KEY	PART NO.	DESCRIPTION		QTY	REMARKS
37	4013000033	螺母 GB6170-M8EpZn-8	NUT GB6170-M8EpZn-8	4	
38	4015000072	垫圈 GB97.1-8EpZn-300HV	WASHER GB97.1-8EpZn-300HV	4	
39	2901000950	空滤器支架	FRAME	1	部件
40	4011000474	螺栓 GB16674-M10*25EpZn-8.8	BOLT GB16674-M10*25EpZn-8.8	6	
41	2010900277	油门操纵机构	GOVERNOR CONTROL SYSTEM	1	部件
42	4015000025	垫圈 GB93-10-65Mn	WASHER GB93-10-65Mn	24	
43	2901000971	双头螺栓	BOLT	8	45
44	2901000954	软轴固定支架	FRAME	1	Q235A
45	2901000955	油门拉杆	STICK	1	Q235A
46	2901000956	燃油回油管	OIL-RETURN PIPE	1	部件
47	2901000957	二通接头	CONNECTOR	1	35
48	2901000958	燃油进油管	OIL-INPUT PIPE	1	部件
49	4120001078	胶管 JB8406-B25*1300	HOSE JB8406-B25*1300	1	
50	4017000008	喉箍 JB8870-d40	CLAMP JB8870-d40	2	部件
51	4011000641	螺栓 JB6013-M14*1.5EpZn-45	BOLT JB6013-M14*1.5EpZn-45	2	
52	4015000231	垫圈 JB6013-14-T2	WASHER JB6013-14-T2	4	
53	4011000236	螺栓 GB5782-M20*130EpZn-8.8	BOLT GB5782-M20*130EpZn-8.8	2	
54	4013000020	螺母 GB6170-M20EpZn-8	NUT GB6170-M20EpZn-8	2	
55	4015000176	垫圈 GB97.1-20EpZn-300HV	WASHER GB97.1-20EpZn-300HV	2	
56	2905000010	减震块	SHOCK MOUNT	4	部件
57	2905000012	垫圈	WASHER	4	Q235A
58	2901000972	水(油)温表接头	WATER(OIL) TEMPERATURE INDICATOR	1	Q235A
59	4011000090	螺栓 GB5783-M12*35EpZn-8.8	BOLT GB5783-M12*35EpZn-8.8	6	
60	4110000179	发动机总成 6BT5.9-C120	DIESEL ENGINE SYSTEM 6BT5.9-C120	1	部件



A2

油门操纵机构

GOVERNOR CONTROL SYSTEM

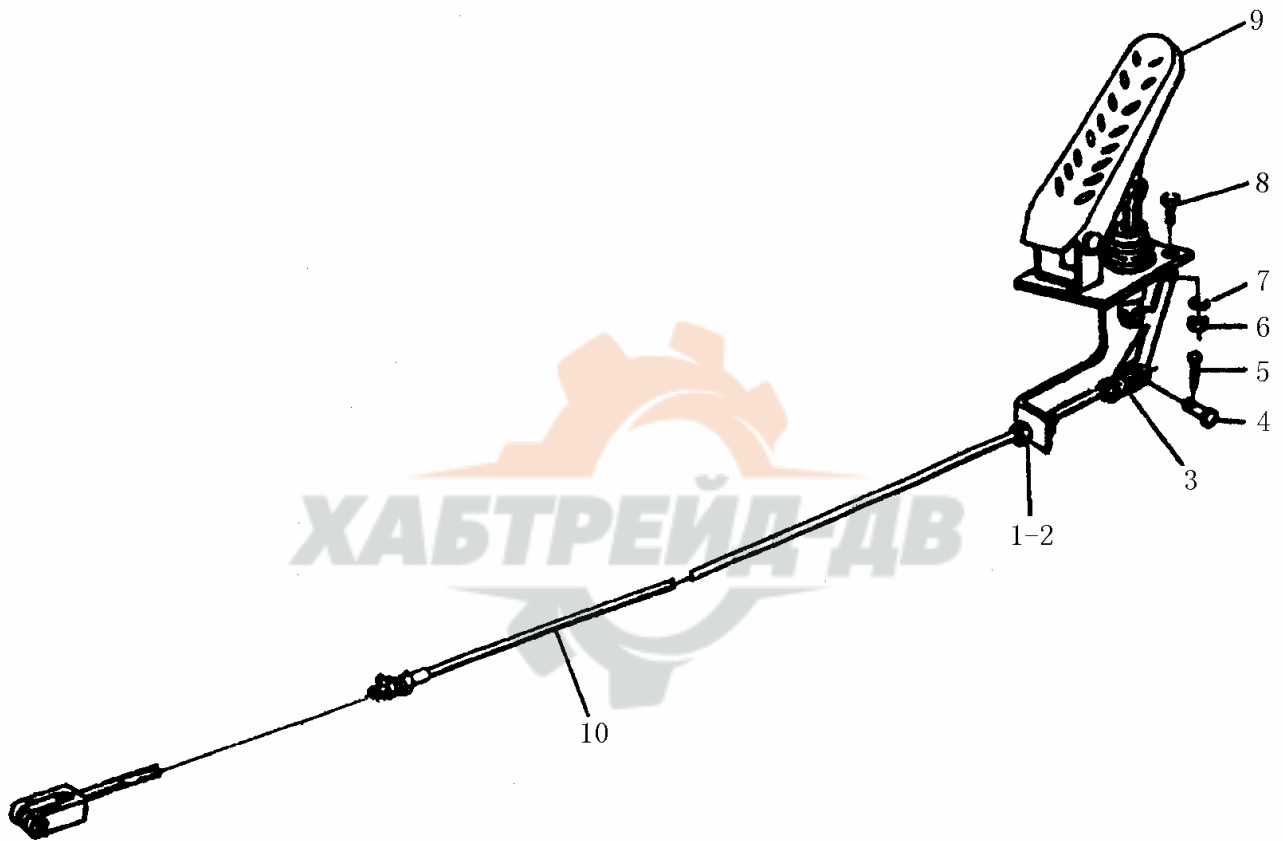

A2

序号	代号	名称		数量	备注
KEY	PART NO.	DESCRIPTION		QTY	REMARKS
1	4013000167	螺母 GB6172-M12EPZN-05	NUT GB6172-M12EPZN-05	4	
2	4015000168	垫圈 GB97.1-12EpZn-300HV	WASHER GB97.1-12EpZn-300HV	4	
3	2901000668	连接叉	JOINT FORK	1	
4	4016000138	销轴 GB882-B6*22EpZn-35	PIN GB882-B6*22EpZn-35	2	
5	4016000114	开口销 GB91-2*16EpZn-Q235A	SPLINT PIN GB91-2*16EpZn-Q235A	2	
6	4013000028	螺母 GB6170-M6EpZn-8	NUT GB6170-M6EpZn-8	3	
7	4015000207	垫圈 GB97.1-6EpZn-300HV	WASHER GB97.1-6EpZn-300HV	6	
8	4011000101	螺栓 GB5783-M6*20EpZn-8.8	BLOT GB5783-M6*20EpZn-8.8	3	
9	4110000271	油门操纵阀 xz (LY)	ACCELERATOR PEDAL xz (LY)	1	部件
10	2901001192	操纵软轴	CABLE SHAFT	1	部件



B 变速箱系统

TRANSMISSION SYSTEM



山东临工工程机械有限公司
SHANDONG LINGONG CONSTRUCTION MACHINERY LTD.

B1

变速箱系统

TRANSMISSION SYSTEM

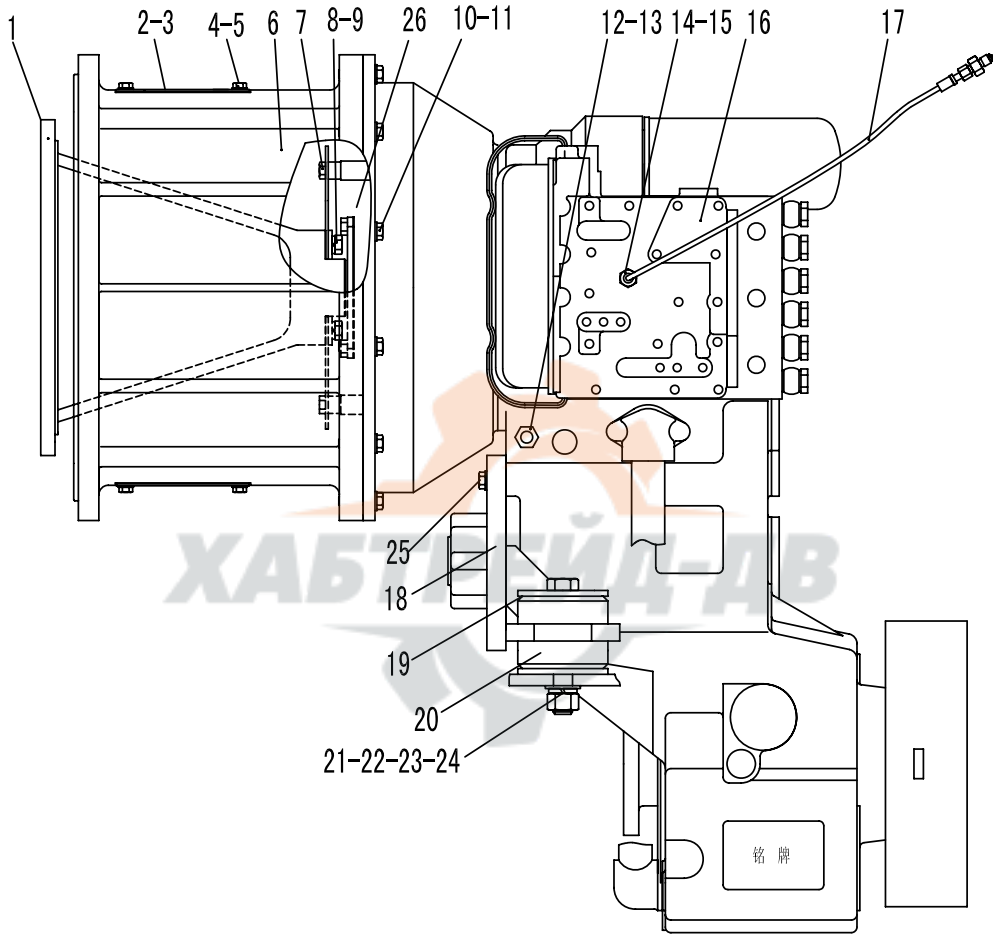

B1

序号	代号	名称		数量	备注
KEY	PART NO.	DESCRIPTION		QTY	REMARKS
1	2905001044	飞轮过渡盘	TRANSITION PAN OF FLYWHEEL	1	ZG270-500
2	2905001045	压盖	COVER	2	Q235A
3	2905001046	垫片	WASHER	2	石棉橡胶板
4	4011000102	螺栓 GB5783-M8*16EpZn-8.8	BOLT GB5783-M8*16EpZn-8.8	8	
5	4015000072	垫圈 GB97.1-8EpZn-300HV	WASHER GB97.1-8EpZn-300HV	8	
6	2905001047	飞轮过渡筒	TRANSITION CANISTER OF FLYWHEEL	1	HT250
7	4011000569	螺栓 GB5783-M10*35EpZn-10.9	BOLT GB5783-M10*35EpZn-10.9	4	
8	4011000197	螺栓 GB5783-M12*25EpZn-8.8	BOLT GB5783-M12*25EpZn-8.8	12	
9	4015000026	垫圈 GB93-12-65Mn	WASHER GB93-12-65Mn	12	
10	4011000184	螺栓 GB5783-M10*40EpZn-8.8	BOLT GB5783-M10*40EpZn-8.8	12	
11	4015000162	垫圈 GB97.1-10EpZn-300HV	WASHER GB97.1-10EpZn-300HV	12	
12	2905000760	变矩器油温表接头	CONNECTOR	1	35
13	4030000057	垫圈 JB1002-14-T2	WASHER	1	
14	2901000111	接头	CONNECTOR	2	35
15	4015000139	垫圈 JB1002-10-T2	WASHER JB1002-10-T2	1	
16	4110000076	变速箱 YD13	TRANSMISSION ASS'Y YD13	1	部件
17	2905001067	变速压力油管	PRESS PIPE	1	部件
18	2905001049	变速箱支架	FRAME	1	部件
19	2905000010	减震块	RUBBER BLOCK	4	部件
20	2905000012	垫圈	WASHER	4	Q235A
21	4011000236	螺栓 GB5782-M20*130EpZn-8.8	BOLT GB5782-M20*130EpZn-8.8	2	
22	4015000030	垫圈 GB93-20-65Mn	WASHER GB93-20-65Mn	6	
23	4015000176	垫圈 GB97.1-20EpZn-300HV	WASHER GB97.1-20EpZn-300HV	2	
24	4013000020	螺母 GB6170-M20EpZn-8	NUT GB6170-M20EpZn-8	2	
25	4015000030	螺栓 GB5783-M20*50EpZn-8.8	BOLT GB5783-M20*50EpZn-8.8	4	
26	YJH315-15	液力变矩器	TORQUE CONVERTER	1	

B2

变速器系统 TRANSMISSION SYSTEM

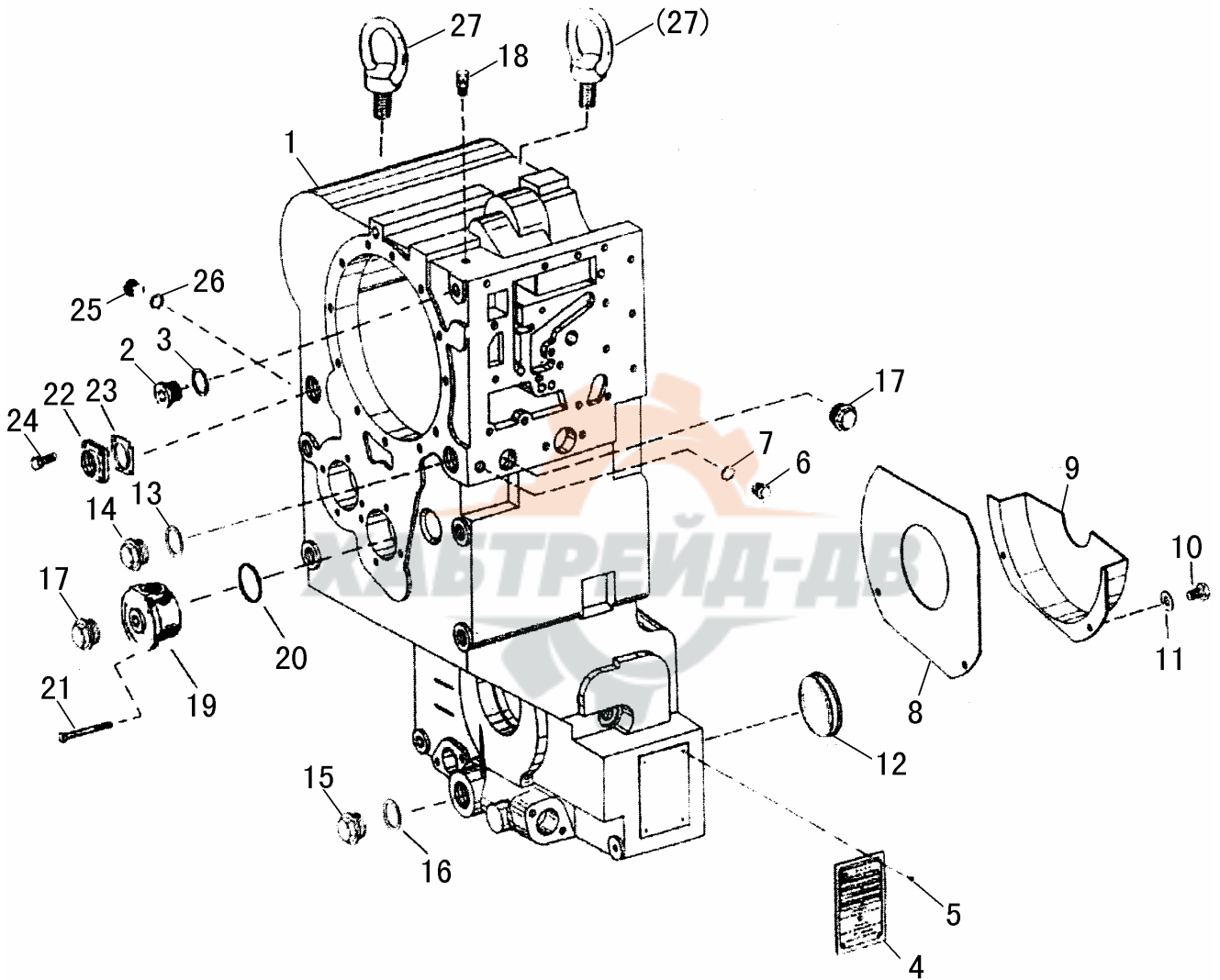

B2

序号	代号	名称		数量	备注
KEY	PART NO.	DESCRIPTION		QTY	REMARKS
1	YD13301006	箱体	GEARBOXHOUSING	1	
2	0636305019	螺塞 M26*1.5	PLUG M26*1.5	1	
3	0634303233	O 形圈 23*2	O-RING 23*2	1	
4	403091A	铭牌	TYPE PLATE	1	
5	GB/T827-1986	铆钉	GROOVE STUD	4	
6	0636305007	螺塞 M14*1.5	PLUG M14*1.5	1	
7	0634306522	O 形圈 11*2	O-RING 11*2	1	
8	YD13301002	盖板	COVER PLATE	1	
9	YD13301003	盖板	COVER PLATE	1	
10	GB/T5783-2000	螺栓 M8*16	BOLT M8*16	2	
11	GB/T848-1985	垫圈 8	WASHER 8	2	
12	4466351081	密封帽	SEALING COVER	2	
13	0634304275	O 形圈 27*2	O-RING 27*2	1	
14	0636305023	螺塞 M30*1.5	PLUG M30*1.5	1	
15	0636305023	螺塞 M30*1.5	PLUG M30*1.5	1	
16	0634304275	O 形圈 27*2	O-RING 27*2	1	
17	0637510206	螺塞 M30*1.5	PLUG M30*1.5	2	
18	0750131027	透气件	BREATHER CAP	1	
19	YD13301004	润滑端盖	LUBE-IN COVER	1	
20	0634113529	O 形圈 27*2	O-RING 27*2	1	
21	GB/T5782-2000	螺栓 M8*70	BOLT M8*70	4	
22	YD13301007	进油口盖	OIL-IN COVER	1	
23	YD13301008	衬垫	GASKET	1	
24	GB/T5783-2000	螺栓 M8*20	BOLT M8*20	4	
25	0636305011	螺塞 M18*1.5	PLUG M18*1.5	1	
26	0636306524	O 形圈 15*2	O-RING 15*2	1	
27	GB/T825-1988	螺钉 M16	SCREW M16	2	

B3

动力输入装置

POWER INPUT

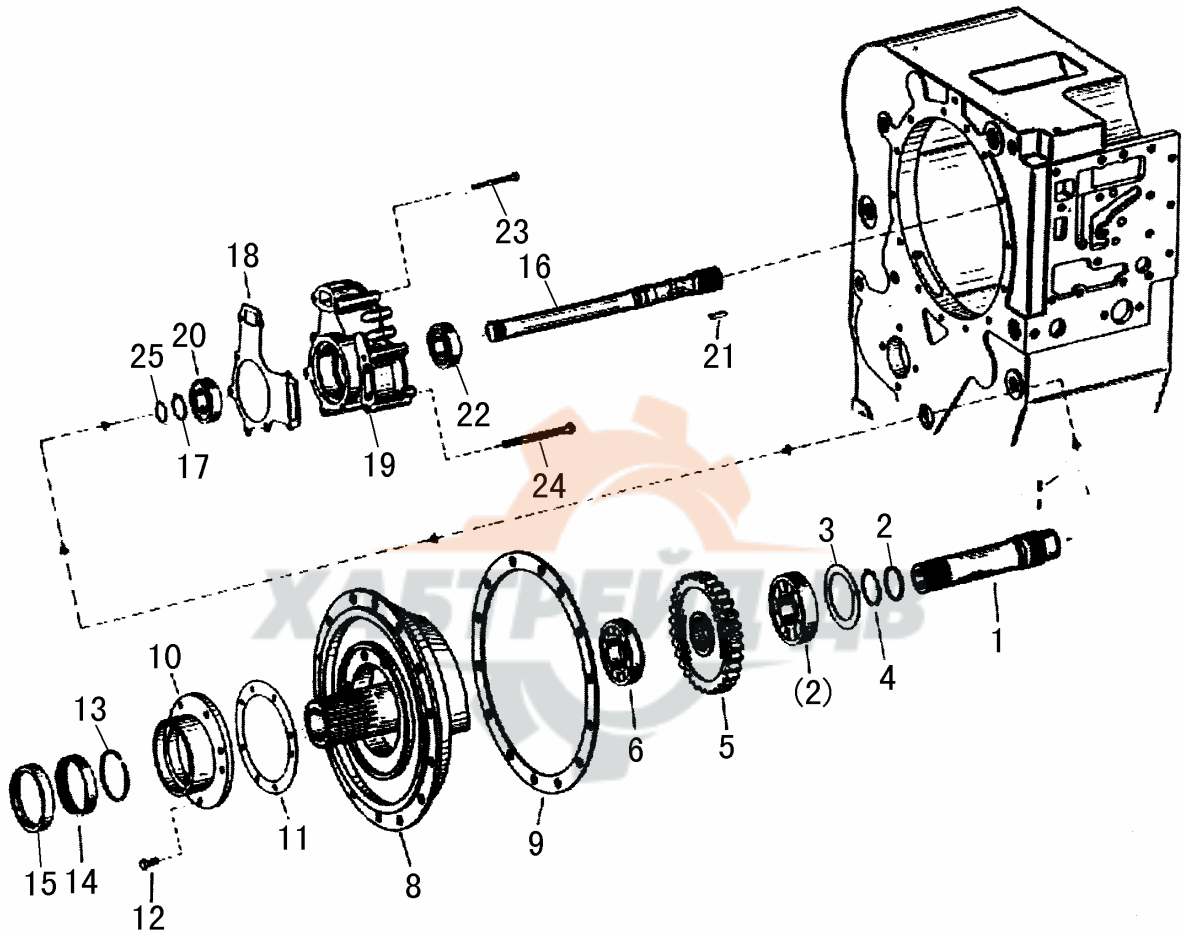

B3

序号	代号	名称		数量	备注
KEY	PART NO.	DESCRIPTION		QTY	REMARKS
1	YD13301002	主动轴	INPUT SHAFT	1	
2	GB/T27-1994	球轴承 6308	BALL BEARING 6308	1	
3	0769120427	补偿垫圈	REGULATING SHIM	1	
4	0630501031	卡环 40*1.75	RETAINING RING 40*1.75	1	
5	YD13301004	主动齿轮 Z=50	INPUT GEAR Z=50	1	
6	GB/T27-1994	滚针轴承 N3263L	NEEDLE BEARING N3263L	1	
7	0734317252	密封环	SEALING RING	1	
8	YD13301001	进油法兰	OIL FEED FLANGAE	1	
9	4644302211	衬垫	GASKET	1	
10	4642301136	轴承座	BEARING SEAT	1	
11	YD13301005	衬垫	GASKET	1	
12	GB/T27-1994	螺栓 M8*25	BOLT M8*25	12	
13	0734401078	密封环	SEALING RING	1	
14	0735298027	滚针轴承 HK75*83*16	NEEDLE BEARING HK75*83*16	1	
15	0750111231	密封环 75*100*10	SEALING RING FOR SHAFT 75*100*10	1	
16	YD13301003	输出轴	STAND-BY DRIVE	1	
17	0634402025	密封环	SEALING RING	1	
18	4644301265	衬垫	GASKET	1	
19	0501004171	齿轮泵	GEAR PUMP	1	
20	GB/T27-1994	球轴承 6206-RS	BALL BEARING 6206-RS	1	
21	GB/T1096-1979	键 6*22	KEY 6*22	1	
22	GB/T27-1994	球轴承 6206-RS	BALL BEARING 6206-RS	1	
23	GB/T5782-2000	螺栓 M8*85	BOLT M8*85	4	
24	GB/T5782-2000	螺栓 M8*110	BOLT M8*110	4	
25	0630501024	卡环 30*1.5	RETAINING RING 30*1.5	1	

B4

动力输出装置

POWER OUTPUT

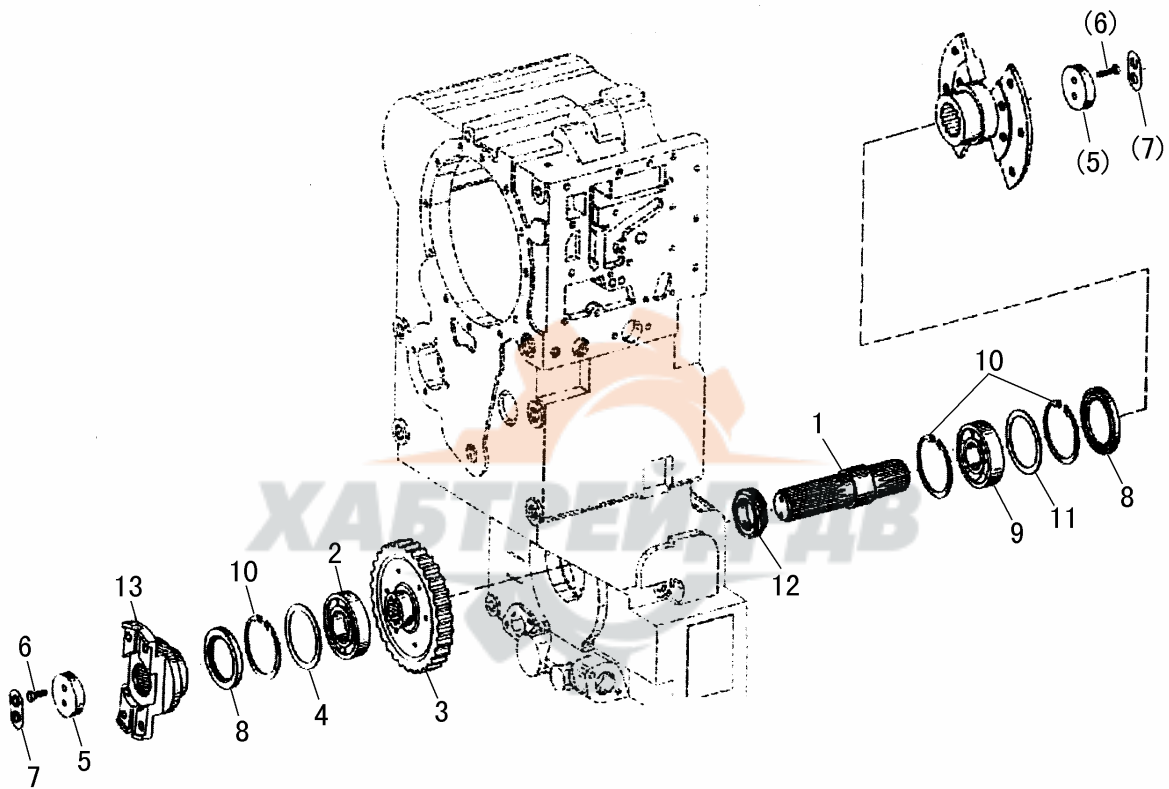

B4

序号	代号	名称		数量	备注
KEY	PART NO.	DESCRIPTION		QTY	REMARKS
1	YD13303001	输出轴	OUT PUT SHAFT	1	
2	YD13303003	输出齿轮	OUT PUT GEAR	1	
3	GB/T283-1994	滚柱轴承 NJ213E	ROLLER BEARING NJ213E	1	
4	1204308062	补偿垫圈	REGULATING SHIM	1	
5	4620303247	压板	PRESS PLATE	2	
6	GB/T5783-2000	螺栓 M10*30	BOLT M10*30	4	
7	1269302164	止动螺钉	RETAINER SCREW	2	
8	0750111116	密封环	SEALING RING FOR SHAFT	2	
9	GB/T276-1994	球轴承 6311	BALL BEARING 6311	1	
10	0630502048	挡圈 120*4	RETAINING RING FOR HOLE 120*4	3	
11	0769120338	补偿垫圈	REGULATING SHIM	1	
12	0730062296	套筒 L=20	SLEEVE L=20	1	
13	YD13301002	输出法兰	OUTPUT FLANGE	1	



B5

控制阀总成(I)

CONTROL VALVE ASSEMBLY(I)

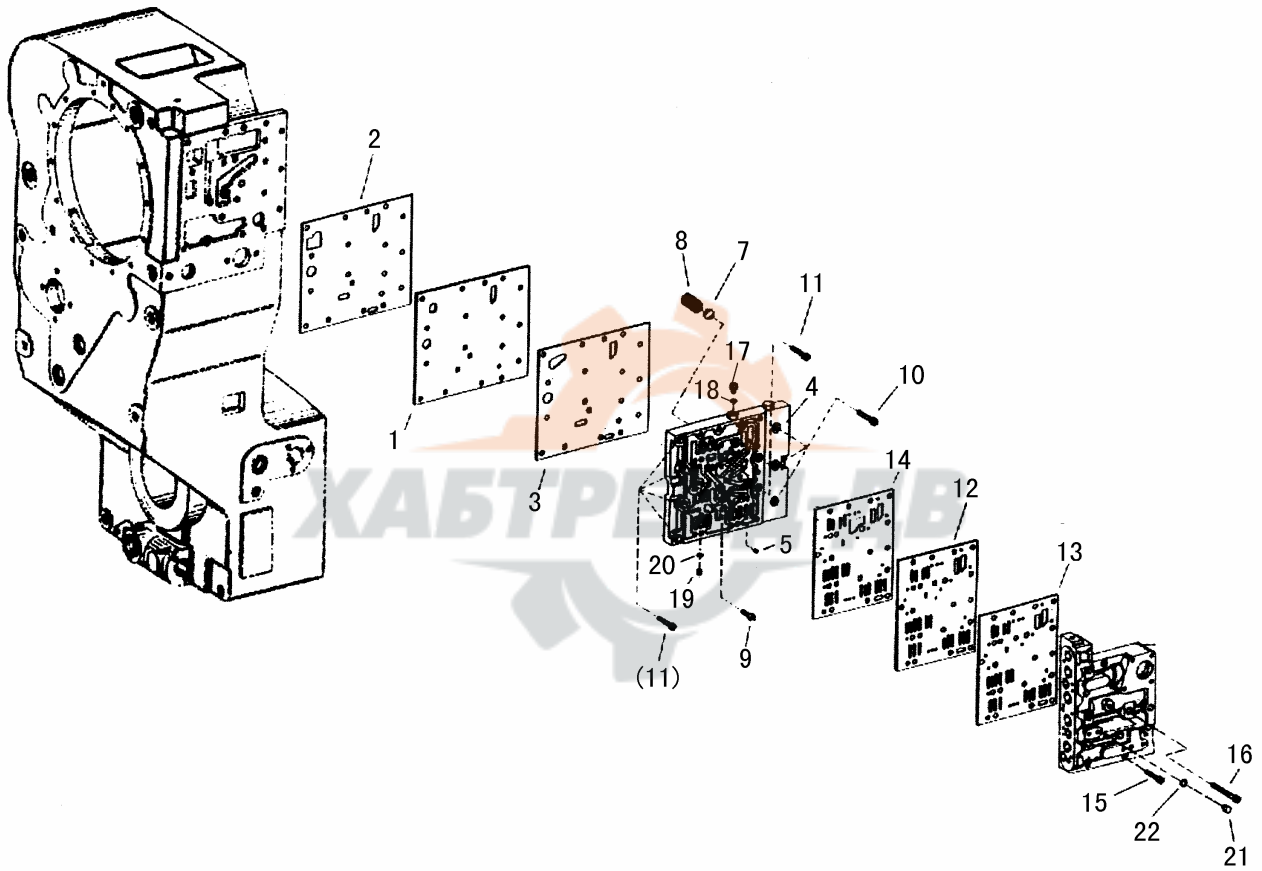

B5

序号	代号	名称		数量	备注
KEY	PART NO.	DESCRIPTION		QTY	REMARKS
1	4642306050	下挡板	LOWER BAFFLE	1	
2	4644306464	密封垫	SEALING PAD	1	
3	4644306466	密封垫	SEALING PAD	1	
4	4642306149	油道板	OIL-LINE PLATE	1	
5	4642306089	节流喷嘴	THROTTLE NOZZLE	1	
6	4642306167	节流喷嘴	THROTTLE NOZZLE	1	
7	0635460027	钢球	STEEL BALL	2	
8	0732041226	弹簧	SPRING	2	
9	0636101031	螺栓 M8*30	BOLT M8*30	3	
10	0636101035	凸头螺栓 M8*45	SOCKET SCREW M8*45	3	
11	0636101032	凸头螺栓 M8*75	SOCKET SCREW M8*75	6	
12	4642306163	上挡板	UPPER BAFFLE	1	
13	4642306318	密封垫	SEALING PAD	1	
14	4642306320	密封垫	SEALING PAD	1	
15	0636101035	凸头螺栓 M8*45	SOCKET SCREW M8*45	10	
16	0636101124	凸头螺栓 M8*35	SOCKET SCREW M8*35	6	
17	0636304019	螺塞 M10*1	PLUG M10*1	1	
18	0634801152	铜垫圈 M10*13.5	COPPER WASHER M10*13.5	1	
19	0631610025	调节螺钉 M10*10	SET SCREW M10*10	1	
20	0634810152	铜垫圈 M10*13.5	COPPER WASHER M10*13.5	1	
21	0636304019	螺塞 M10*1	PLUG M10*1	1	
22	0634801152	铜垫圈 M10*13.5	COPPER WASHER M10*13.5	1	



B6

转速表 SPEEDOMETER

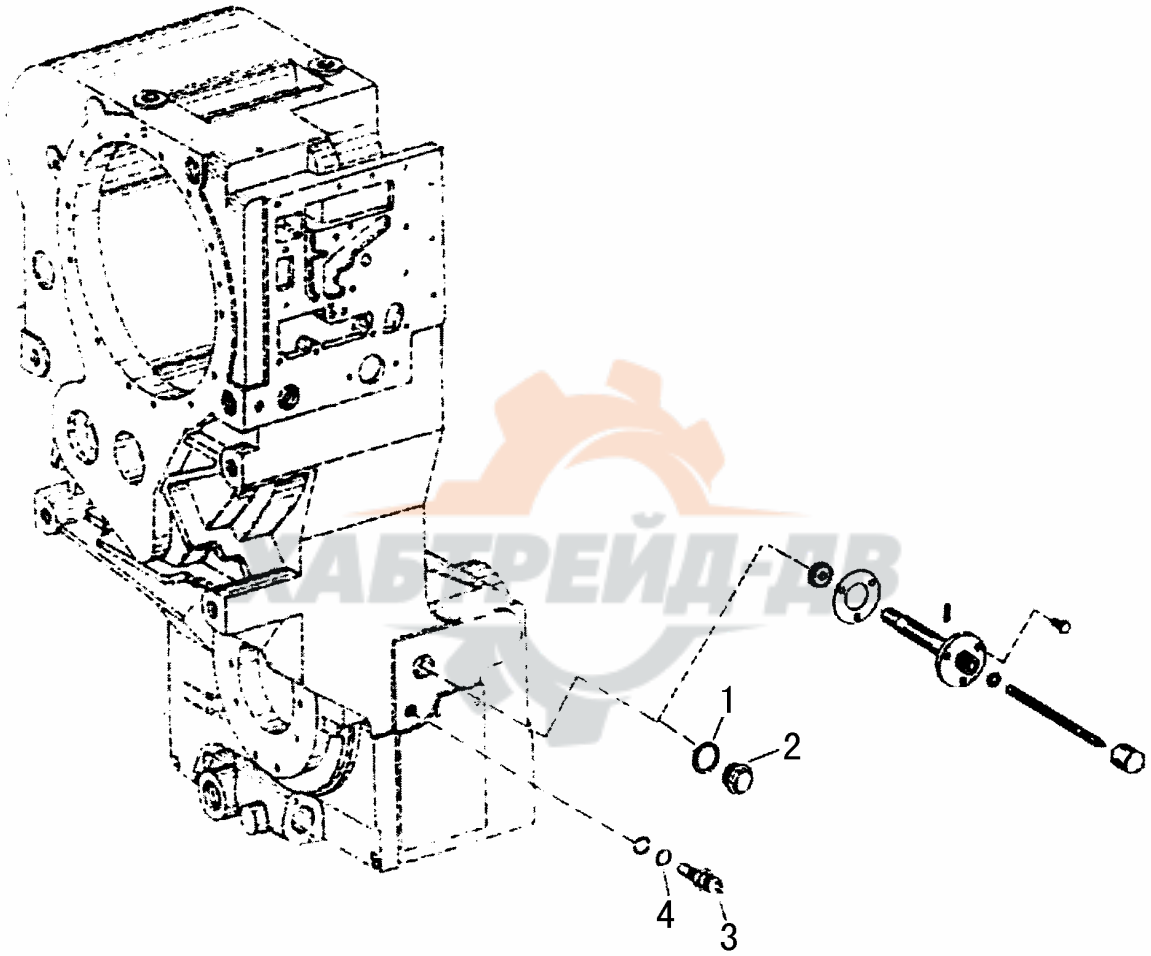

B6

序号	代号	名称	数量	备注
KEY	PART NO.	DESCRIPTION	QTY	REMARKS
1	Q20-03	垫圈 36	WASHER 36	1
2	0636302018	螺塞 M36*1.5	PLUG M36*1.5	1
3	0636305011	螺塞 AM18*1.5	PLUG AM18*1.5	1
4	0636306024	O形圈 15*2	O-RING 15*2	1



空转轮 IDLE WHEEL

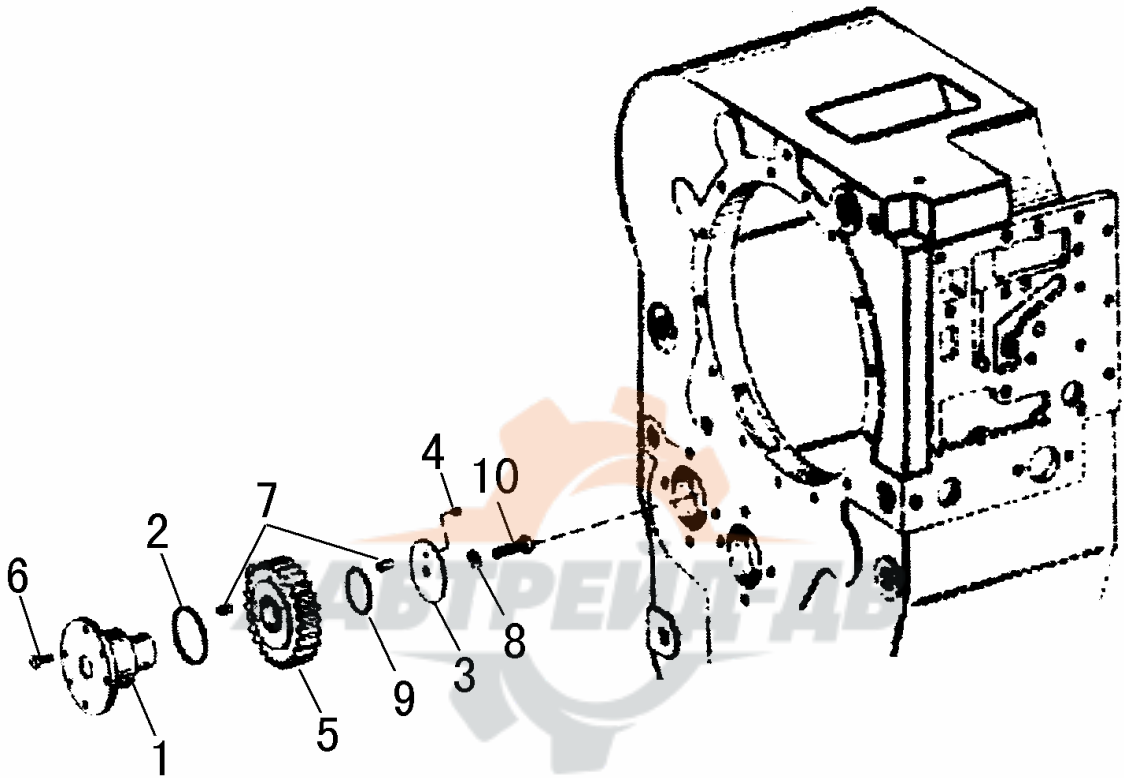

B7

序号	代号	名称		数量	备注
KEY	PART NO.	DESCRIPTION		QTY	REMARKS
1	YD13308003	空转轮轴	IDLE WHEEL SHAFT	1	
2	0634313529	O形圈 57*3	O-RING 57*3	1	
3	4644308542	止推垫片	THRUST SHIM	1	
4	GB/T119.2-2000	销轴 A4*10	PIN A4*10	1	
5	YD13308001	空转轮 Z=34	IDLE WHEEL Z=34	1	
6	GB/T5783-2000	螺栓 M8*20	BOLT M8*20	4	
7	YD13308002	滚柱	ROLLER GROUP	1	
8	GB/T97.2-1985	垫圈 10	WASHER 10	1	
9	0501308832	卡环	RETAINING RING	1	
10	GB/T5783-2000	螺栓 M10*20	BOLT M10*20	1	



离合器 151 CLUTCH 151 KV+K1

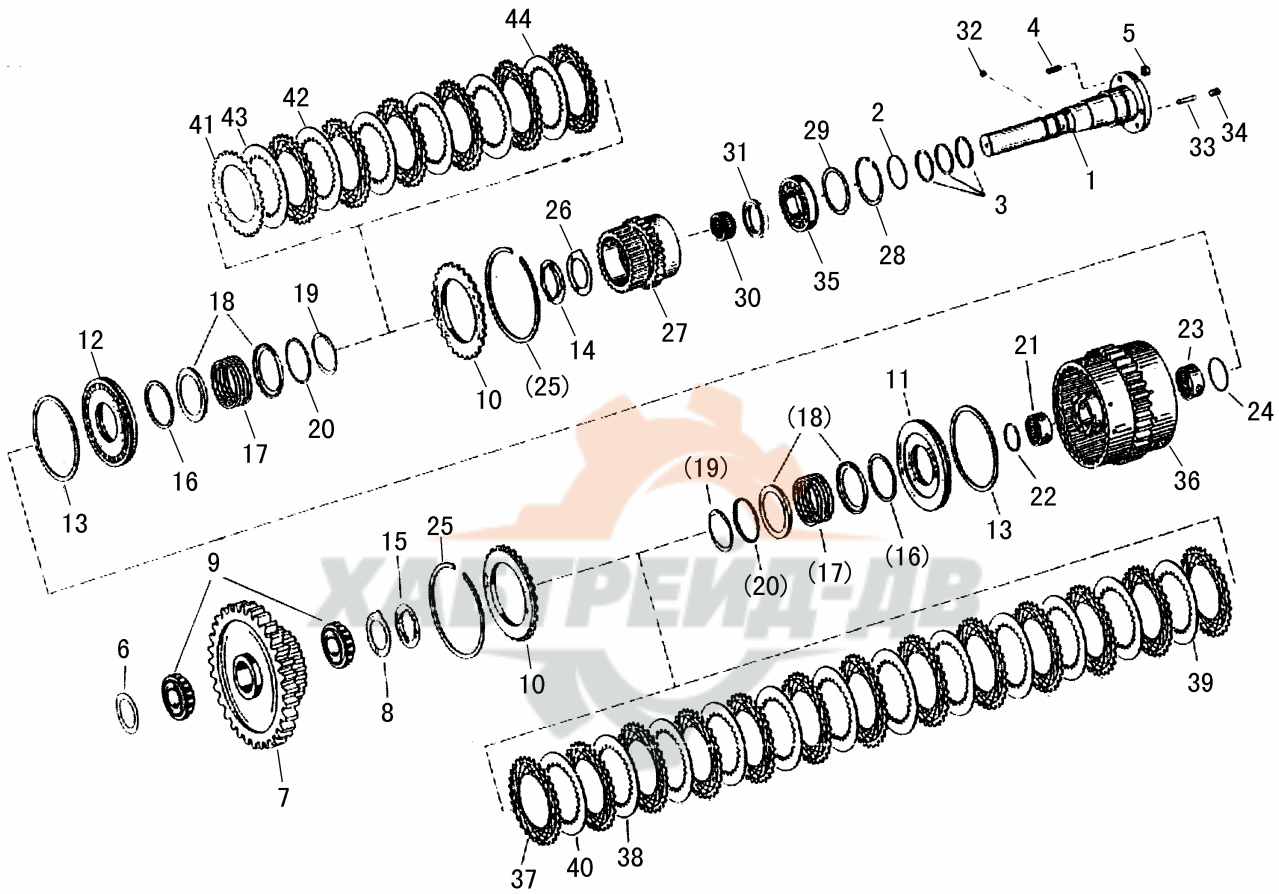

B8

序号	代号	名称		数量	备注
KEY	PART NO.	DESCRIPTION		QTY	REMARKS
1	YD13351008	轮轴	AXLE	1	
2	0634313516	O形圈 49*3	O-RING 49*3	1	
3	0734401106	密封环	SEALING RING	3	
4	GB/T898-1988	螺柱 M8*18	STUD M8*18	3	
5	GB/T6170-2000	螺母 M8	NUT M8	3	
6	0769120468	补偿垫圈	REGULATING SHIM	1	
7	YD13351006	齿轮 Z=50	GEAR Z=50	1	
8	0730150774	止推垫圈	THRUST WASHER DUP	1	
9	YD13351007	轴承	BEARING	1	
10	4642308185	压榨纸板	PRESS BOARD	2	
11	4644353051	活塞	PISTON	1	
12	4644353051	活塞	PISTON	1	
13	0750112141	特殊密封环	SPECIAL SEALING RING	2	
14	4644351094	端垫	LIMIT PLATE	1	
15	4642308555	端垫	LIMIT PLATE	1	
16	0750112140	特殊密封环	SPECIAL SEALING RING	2	
17	0732041183	压力弹簧	PRESSURE SPRING	2	
18	4642308083	导轮环	GUIDE RING	4	
19	0630531346	滚针轴承	NEEDLE BEARING	2	
20	4642308084	柔性卡环	FLEXIBLE RETAINING RING	2	
21	0750115182	滚针轴承	NEEDLE BEARING	1	
22	0730513610	柔性卡环	FLEXIBLE RETAINING RING	1	
23	0635303204	滚针轴承	NEEDLE BEARING	1	
24	0730150779	柔性卡环	FLEXIBLE RETAINING RING	1	
25	0769124115	柔性卡环	FLEXIBLE RETAINING RING	2	
26	0730150779	止推垫圈	THRUST WASHER DUP	1	
27	YD13351113	齿轮 Z=25	GEAR Z=25	1	
28	0630502037	卡环 75*2.5	RETAINING RING FOR HOLE 75*2.5	1	
29	0769120556	补偿垫圈	REGULATING SHIM	1	
30	0750115109	滚针组	NEEDLE SET	1	
31	4644351029	密封环	RETAINING RING	1	
32	GB/T308-1989	钢球 10	STEEL BALL 10	2	
33	4642351015	直销	STRAIGHT PIN	2	
34	GB/T79-2000GB	螺钉 M12*20	SCREW M12*20	2	
35	GB/T276-1994	球轴承 6009	BALL BEARING 6009	1	
36	YD13251001	离合器	CLUTCH ASS'Y	1	
37	0501309329	外摩擦片 S=2.0	EX. FRICTIONAL DISC S=2.0	13	
38	4642308330	内摩擦片 S=1.5	IN. FRICTIONAL DISC S=1.5	5	
39	4642308332	内摩擦片 S=2.0	IN. FRICTIONAL DISC S=2.0	6	
40	1769129011	内摩擦片 D=137.5 S=2.0	IN. FRICTIONAL DISC S=1.5/2.0/2.5	1	
41	0501309329	外摩擦片 D=137.5 S=2.0	EX. FRICTIONAL DISC D=137.5 S=2.0	9	
42	4642308330	内摩擦片 S=1.5	IN. FRICTIONAL DISC S=1.5	6	
43	4642308332	内摩擦片 S=2.0	IN. FRICTIONAL DISC S=2.0	1	
44	0769129011	内摩擦片 S=1.5/2.0/2.5	IN. FRICTIONAL DISC S=1.5/2.0/2.5	1	

B9

离合器 152

CLUTCH 152 KR+K2

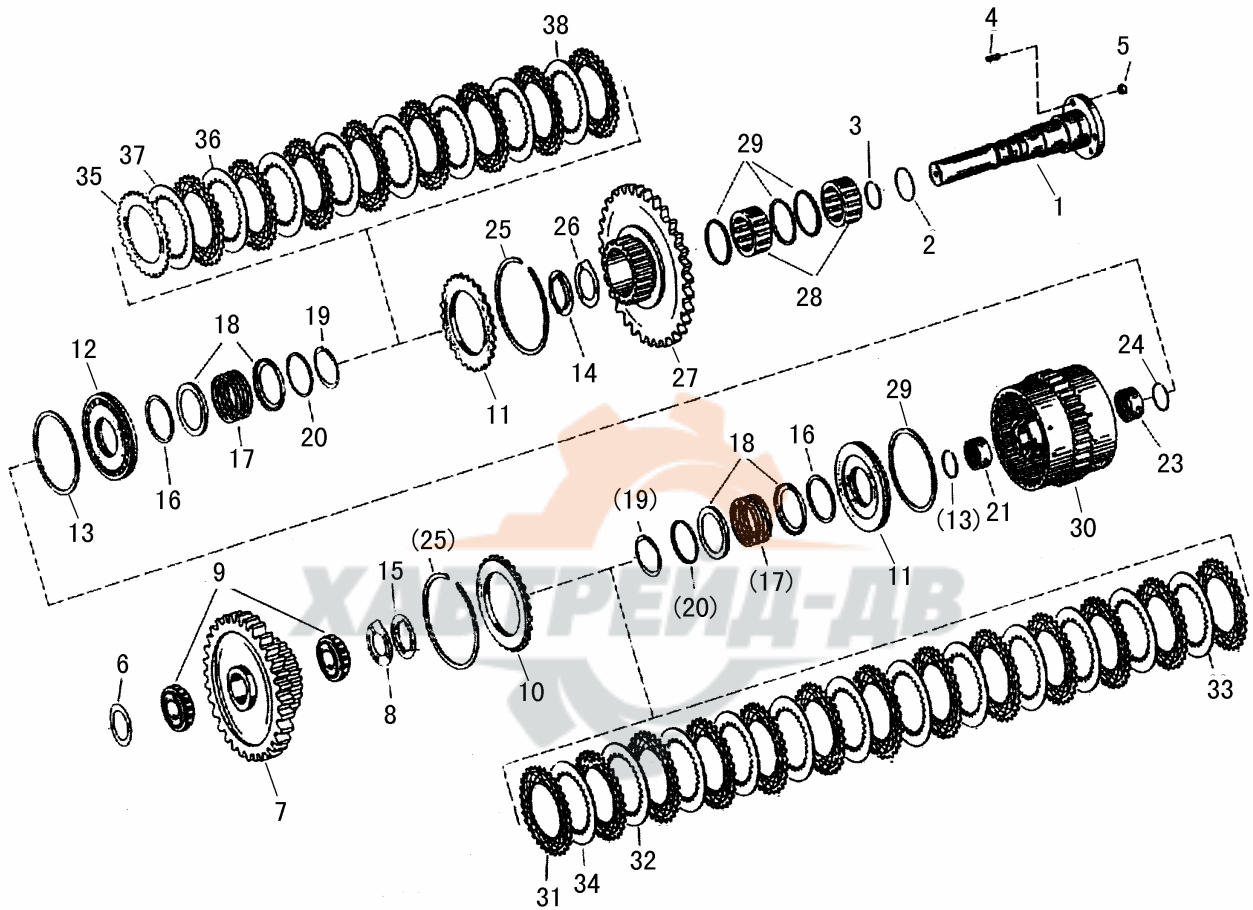

B9

序号	代号	名称		数量	备注
KEY	PART NO.	DESCRIPTION		QTY	REMARKS
1	YD13352009	轮轴	AXLE	1	
2	0632313536	O形圈 49*3	O-RING 49*3	1	
3	0734401106	密封环	SEALING RING	3	
4	GB/T898--1988	螺柱 M8*18	STUD M8*18	3	
5	GB/T6170-2000	螺母 M8	NUT M8	3	
6	0769120468	补偿垫圈	REGULATING SHIM	1	
7	YD13351006	齿轮 Z=50	GEAR Z=50	1	
8	0730150774	止推垫圈	THRUST WASHER DUP	1	
9	YD13351007	轴承	BEARING	1	
10	4642308185	压榨纸板	PRESS BOARD	2	
11	4644353051	活塞	PISTON	1	
12	4644353051	活塞	PISTON	1	
13	0750112141	特殊密封环	SPECIAL SEALING RING	2	
14	4644351094	端垫	LIMIT PLATE	1	
15	4642308084	端垫	LIMIT PLATE	1	
16	0750112140	特殊密封环	SPECIAL SEALING RING	2	
17	0732041183	压力弹簧	PRESSURE SPRING	2	
18	4642308083	导轮环	GUIDE RING	4	
19	0630531346	卡环 AV55	RETAINING RING AV55	2	
20	4642308084	导轮环	GUIDE RING	2	
21	0750115182	滚针轴承	NEEDLE BEARING	1	
22	0730513610	柔性卡环	FLEXIBLE RETAINING RING	1	
23	0635303204	滚针轴承	NEEDLE BEARING	1	
24	0730513611	柔性卡环	FLEXIBLE RETAINING RING	1	
25	0769124115	柔性卡环	FLEXIBLE RETAINING RING	2	
26	0730150779	止推垫圈	THRUST WASHER DUP	1	
27	YD13252009	齿轮 Z=64/23	GEAR Z=64/23	1	
28	YD13352015	滚子轴承	ROLLER BEARING	1	
29	YD133520110	卡环	RETAINING RING	3	
30	YD13251001	离合器	CLUTCH ASS'Y	1	
31	0501309329	外摩擦片 S=2.0	EX. FRICTIONAL DISC S=2.0	13	
32	4642308330	内摩擦片 S=1.5	IN. FRICTIONAL DISC S=1.5	5	
33	4642308332	内摩擦片 S=2.0	IN. FRICTIONAL DISC S=2.0	6	
34	0769129011	内摩擦片 S=1.5/2.0/2.5	IN. FRICTIONAL DISC S=1.5/2.0/2.5	1	
35	0501309329	外摩擦片 D=137.5 S=2.0	EX. FRICTIONAL DISC D=137.5 S=2.0	9	
36	4642308330	内摩擦片 S=1.5	IN. FRICTIONAL DISC S=1.5	6	
37	4642308332	内摩擦片 S=2.0	IN. FRICTIONAL DISC S=2.0	1	
38	0769129011	内摩擦片 S=1.5/2.0/2.5	IN. FRICTIONAL DISC S=1.5/2.0/2.5	1	

B10

离合器 153

CLUTCH 153 K4+K3

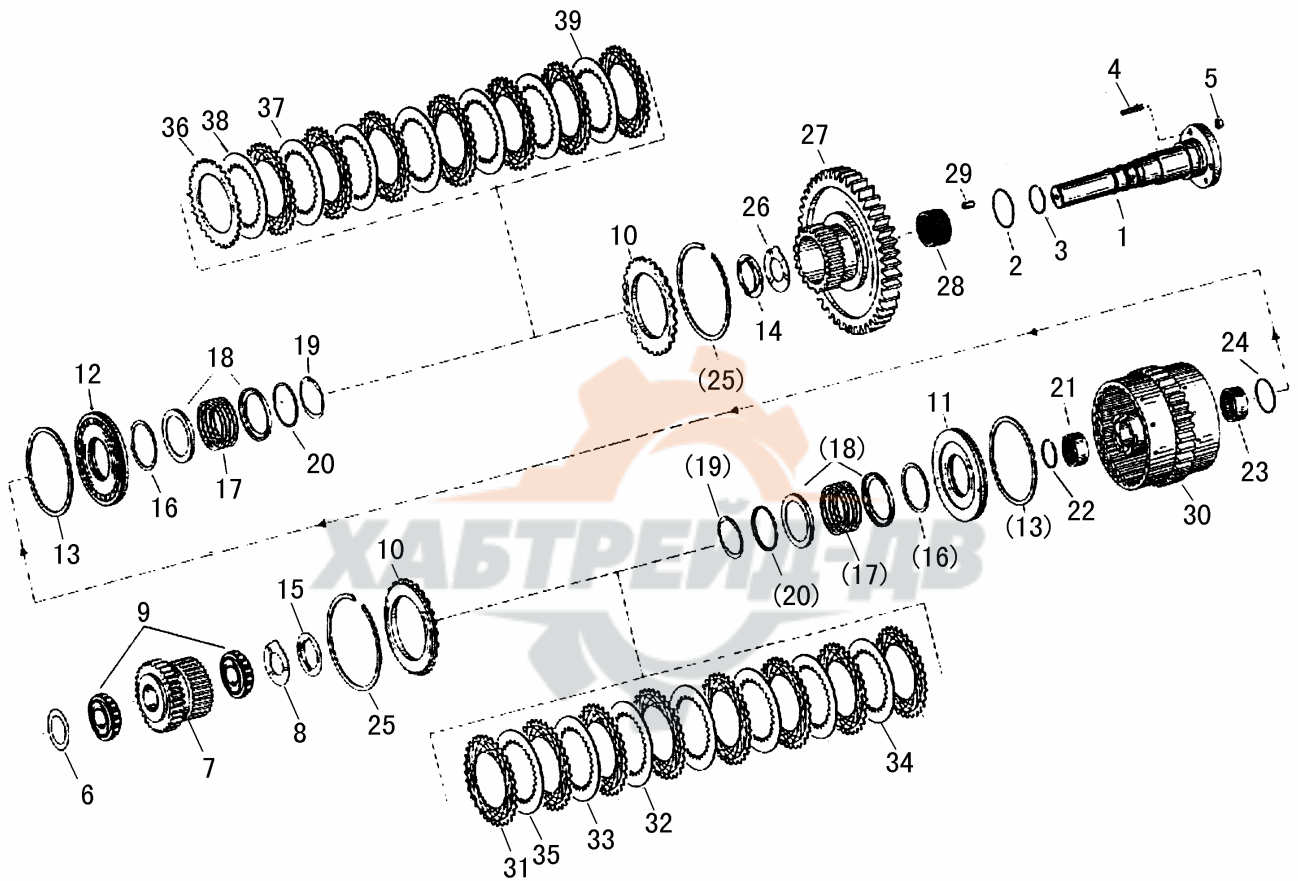

B10

序号	代号	名称		数量	备注
KEY	PART NO.	DESCRIPTION		QTY	REMARKS
1	YD13353012	轮轴	AXLE	1	
2	0632313536	O形圈 49*3	O-RING 49*3	1	
3	0734401106	密封环	SEALING RING	3	
4	GB/T898--1988	螺柱 M8*18	STUD M8*18	3	
5	GB/T6170-2000	螺母 M8	NUT M8	3	
6	0769120468	补偿垫圈	REGULATING SHIM	1	
7	YD13353002	齿轮 Z=32	GEAR Z=32	1	
8	0730150774	止推垫圈	THRUST WASHER DUP	1	
9	YD13351007	轴承	BEARING	1	
10	4642308185	压榨纸板	PRESS BOARD	2	
11	4644353051	活塞	PISTON	1	
12	4644353051	活塞	PISTON	1	
13	0750112141	密封环	SEALING RING	2	
14	4644351094	端垫	LIMIT PLATE	1	
15	4642308084	端垫	LIMIT PLATE	1	
16	0750112140	密封环	SEALING RING	2	
17	0732041183	压力弹簧	PRESSURE SPRING	2	
18	4642308083	导轮环	GUIDE RING	4	
19	0630531346	卡环 AV55	RETAINING RING AV55	2	
20	4642308084	导轮环	GUIDE RING	2	
21	0750115182	滚针轴承	NEEDLE BEARING	1	
22	0730513610	柔性卡环	FLEXIBLE RETAINING RING	1	
23	0635303204	滚针轴承	NEEDLE BEARING	1	
24	0730513611	柔性卡环	FLEXIBLE RETAINING RING	1	
25	0769124115	柔性卡环	FLEXIBLE RETAINING RING	2	
26	0730150779	止推垫圈	THRUST WASHER DUP	1	
27	YD13252009	齿轮 Z=55	GEAR Z=55	1	
28	YD13352015	滚子轴承	ROLLER BEARING	1	
29	0750115109	滚针组	NEEDLE SET	1	
30	YD13251001	离合器	CLUTCH ASS'Y	1	
31	0501309329	外摩擦片 S=2.0	EX. FRICTIONAL DISC S=2.0	8	
32	4642308332	内摩擦片 S=2.0	IN. FRICTIONAL DISC S=2.0	3	
33	4642308330	内摩擦片 S=1.5	IN. FRICTIONAL DISC S=1.5	2	
34	4642308331	内摩擦片 S=2.5	IN. FRICTIONAL DISC S=2.5	1	
35	0769129011	内摩擦片 S=1.5/2.0/2.5	IN. FRICTIONAL DISC S=1.5/2.0/2.5	1	
36	0501309329	外摩擦片 D=137.5 S=2.0	EX. FRICTIONAL DISC D=137.5 S=2.0	8	
37	4642308332	内摩擦片 S=2.0	IN. FRICTIONAL DISC S=2.0	5	
38	4642308331	内摩擦片 S=2.5	IN. FRICTIONAL DISC S=2.5	1	
39	0769129011	内摩擦片 S=1.5/2.0/2.5	IN. FRICTIONAL DISC S=1.5/2.0/2.5	1	

B11

停车制动系统

PARKING BRAKE ASS' Y

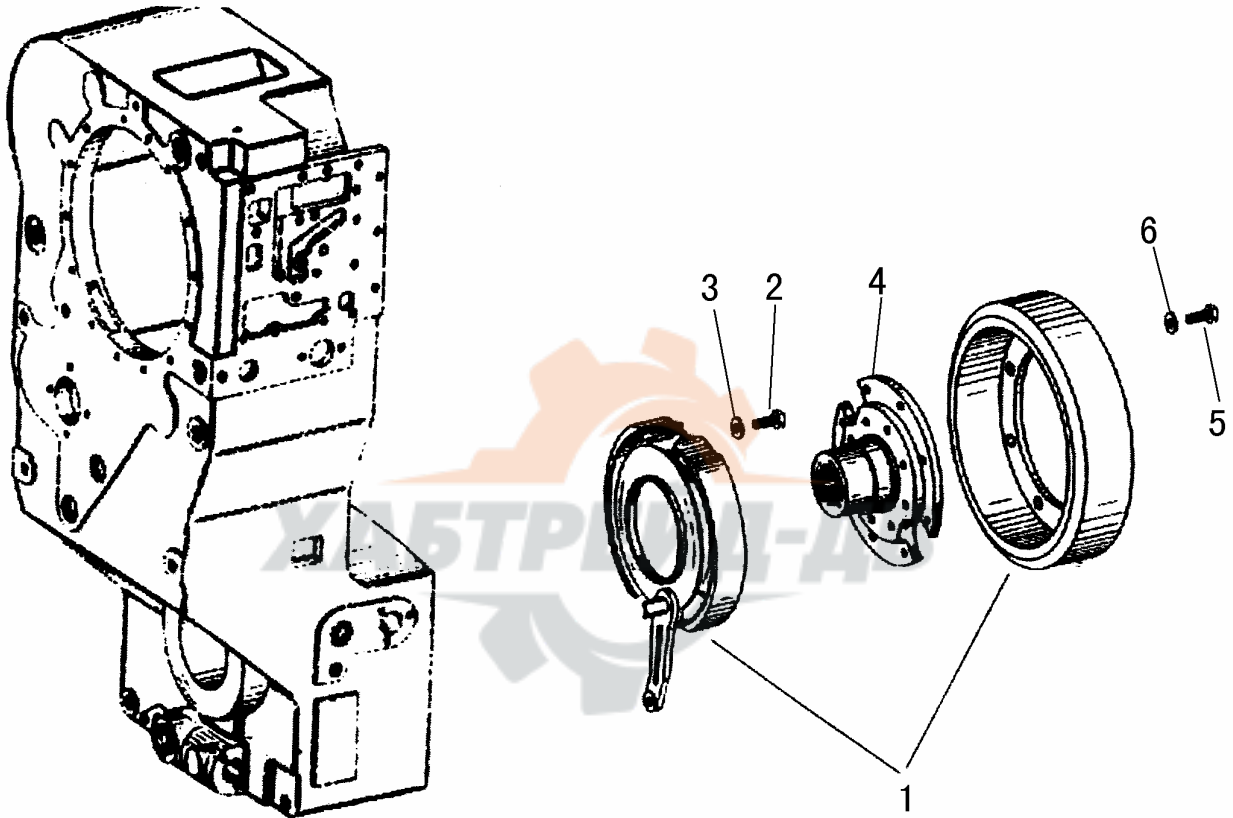

B11

序号	代号	名称		数量	备注
KEY	PART NO.	DESCRIPTION		QTY	REMARKS
1	YD13209001	行车制动器	PARKING BRAKE	1	
2	GB/T5783-2000	螺栓 M14*30	BOLT M14*30	4	
3	GB/T97-1987	垫圈 14	WASHER 14	4	
4	YD13303005	制动器法兰	PARKING BRAKE FLANGE	1	
5	GB/T5783-2000	螺栓 M10*325	BOLT M10*325	8	
6	GB/T97-1987	垫圈 10	WASHER 10	8	



B12

变速压力阀 PRESSURE VALVE

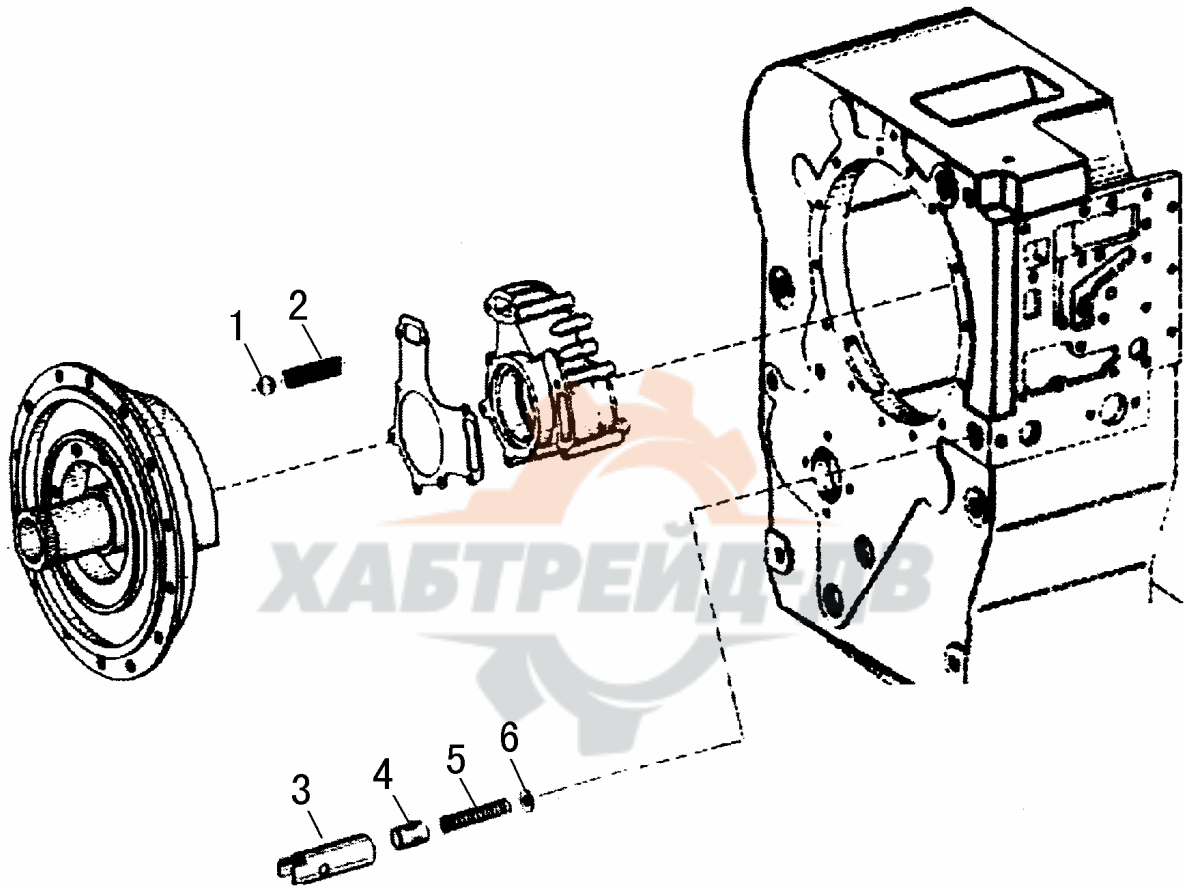

B12

序号	代号	名称		数量	备注
KEY	PART NO.	DESCRIPTION		QTY	REMARKS
1	GB/T308-1989	钢球 20	STEEL BALL 20	1	
2	0732041352	压力弹簧	PRESSURE SPRING	1	
3	YD13320001	阀扣	VALVE BUCKLE	1	
4	4044306022	阀柱	VALVE CORE	1	
5	4068306029	弹簧	SPRING	1	
6	YD13320002	阀座	VALVE SEAT	1	



B13

加油管总成

SUCTION PIPE ASS'Y

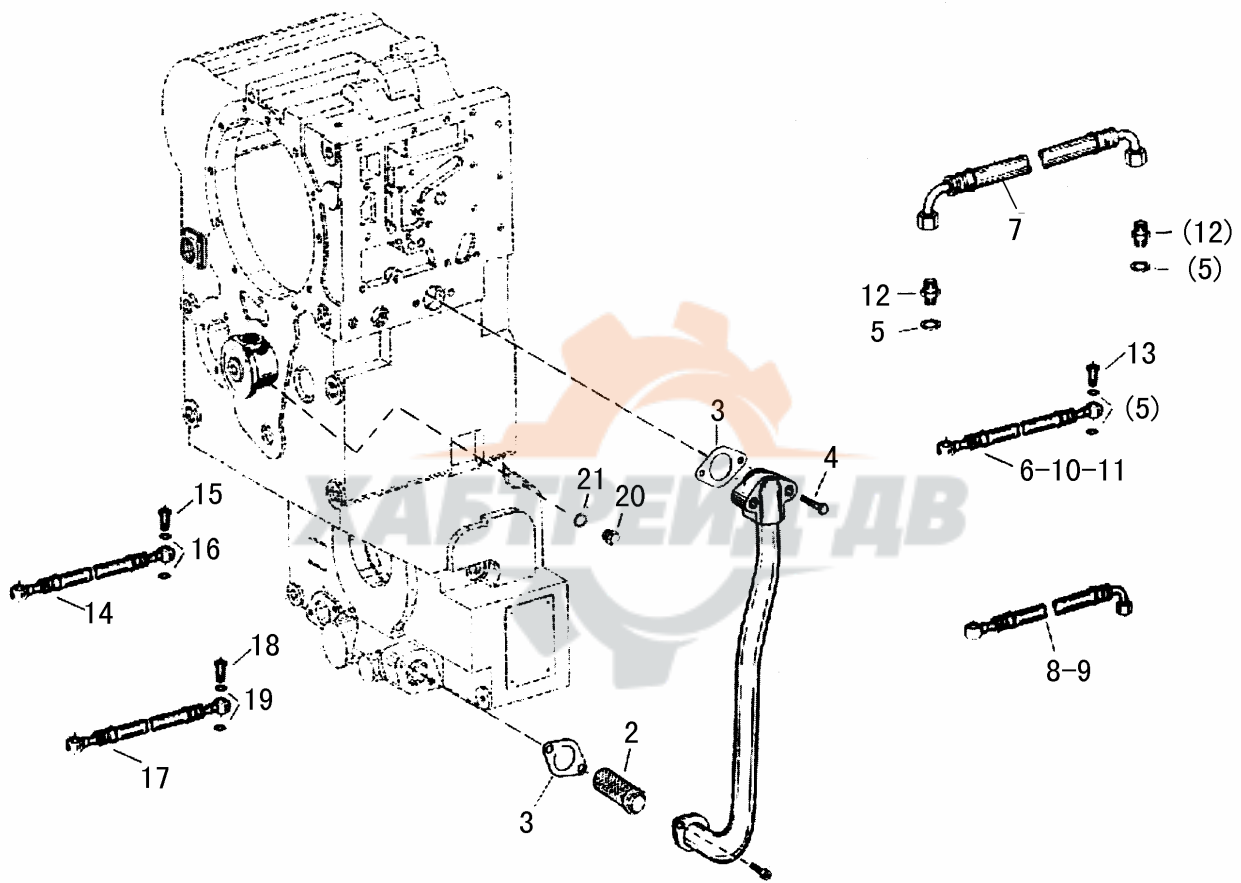

B13

序号	代号			数量	备注
KEY	PART NO.	DESCRIPTION		QTY	REMARKS
1	YD12221001	吸油管	SUCTION PIPE ASS'Y	1	
2	4644221821	吸油管	SUCTION PIPE ASS'Y	1	
3	4644321244	衬垫	GASKET	2	
4	GB/T5782-2000	螺栓 M8*50	BOLT M8*50	4	
5	Q20-03	垫圈 16	WASHER 16	20	
6	0501204427	胶管 L=516/2, Φ16	HOSE TUBE L=516/2, Φ16	1	
7	0501204673	胶管 L=530/2, Φ16	HOSE TUBE L=530/2, Φ16	1	
8	0501204523	胶管 L=818/1, Φ16/1, M18*1.5	HOSE TUBE L=818/1, Φ16/1, M18*1.5	1	
9	0501204422	胶管 L=526/1, Φ16/1, M18*1.5	HOSE TUBE L=526/1, Φ16/1, M18*1.5	1	
10	0501204427	胶管 L=516/2, Φ16	HOSE TUBE L=516/2, Φ16	1	
11	0501204427	胶管 L=516/2, Φ16	HOSE TUBE L=516/2, Φ16	1	
12	0637842509	接套 M18/16*1.5	ADAPTER M18/16*1.5	4	
13	0737835153	带槽螺柱 M16*1.5	HOLLOW BOLT M16*1.5	8	
14	YD13211002	吸油胶管 M22	SUCTION TUBE M22	1	
15	Q21-18	带槽螺柱 M22*1.5	HOLLOW BOLT M22*1.5	2	
16	Q20-03	垫圈 22	WASHER 22	4	
17	YD13211003	吸油胶管 M14	SUCTION TUBE M14	1	
18	Q21-19	带槽螺柱 M14*1.5	HOLLOW BOLT M14*1.5	2	
19	Q20-03	垫圈 14	WASHER 14	4	
20	0636305007	螺塞 AM14*1.5	PLUG AM14*1.5	1	
21	Q20-03	垫圈 16	WASHER 16	1	

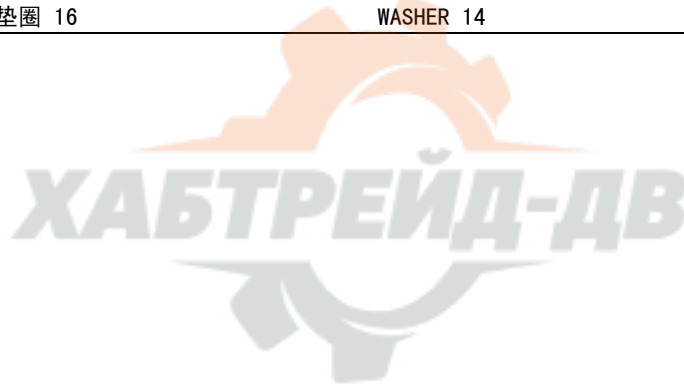

B14

油管、滤清器

OIL PIPE, FILTER

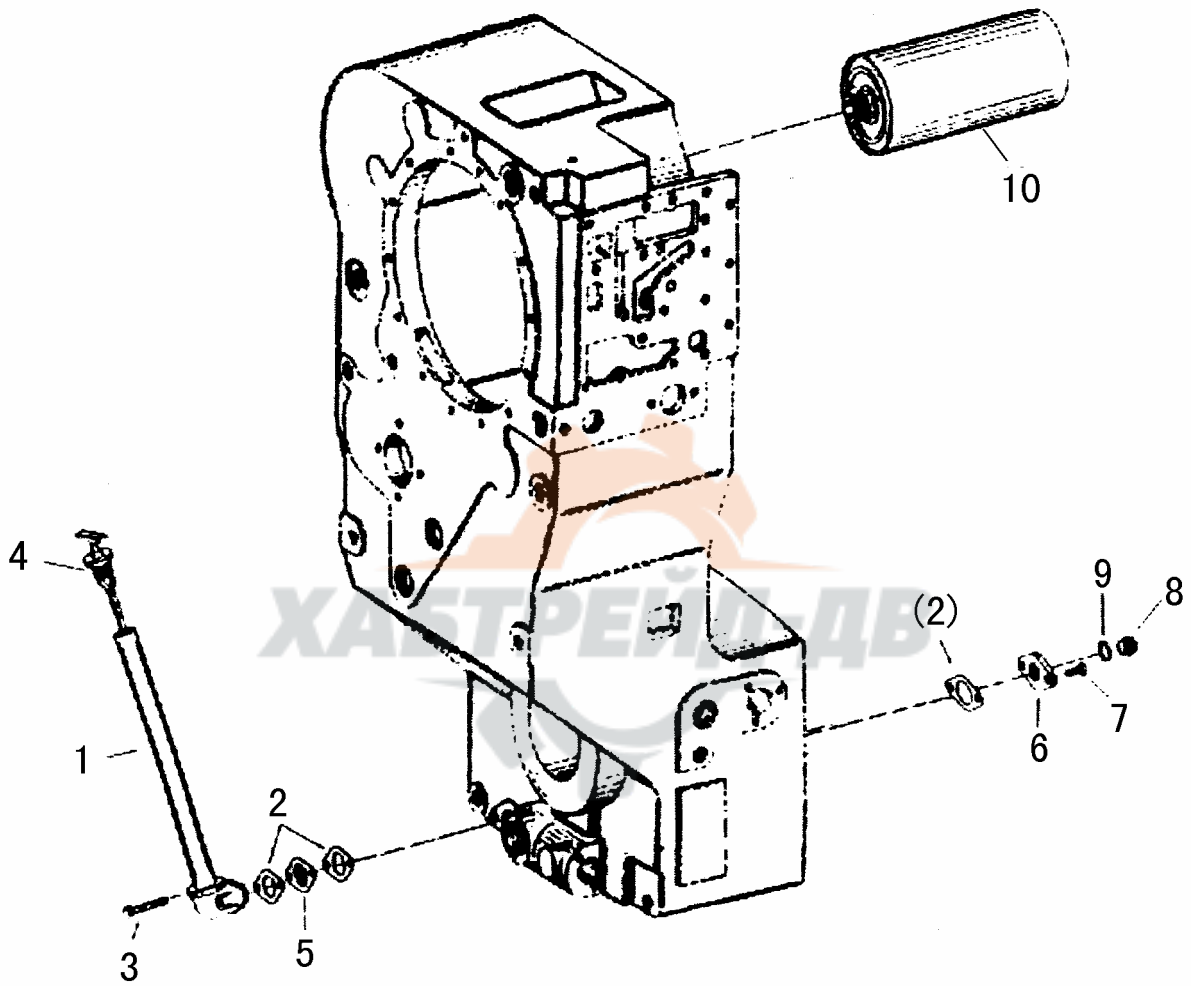

B14

序号	代号			数量	备注
KEY	PART NO.	DESCRIPTION		QTY	REMARKS
1	YD13231001	油管总成	OILING PIPE ASS'Y	1	
2	4842331216	衬垫	GASKET	3	
3	BG/T5783-2000	螺栓 M8*16	BOLT M8*16	2	
4	4644331086	油标尺 (A=279)	DIPSTICK ASS, Y	1	
5	4644331056	挡板	BAFFLE	1	
6	4644301016	盖板	COVER PALTE	1	
7	BG/T5783-2000	螺栓 M8*16	BOLT M8*16	2	
8	0636305016	螺塞 AM22*1.5	PLUG AM22*1.5	1	
9	Q20-03	铜垫圈 22	COPPER WASHER 22	1	
10	0750131053	可换式滤清器	FILTER	1	



B15

取力器

POWER TAKE-OFF (P.T.O)

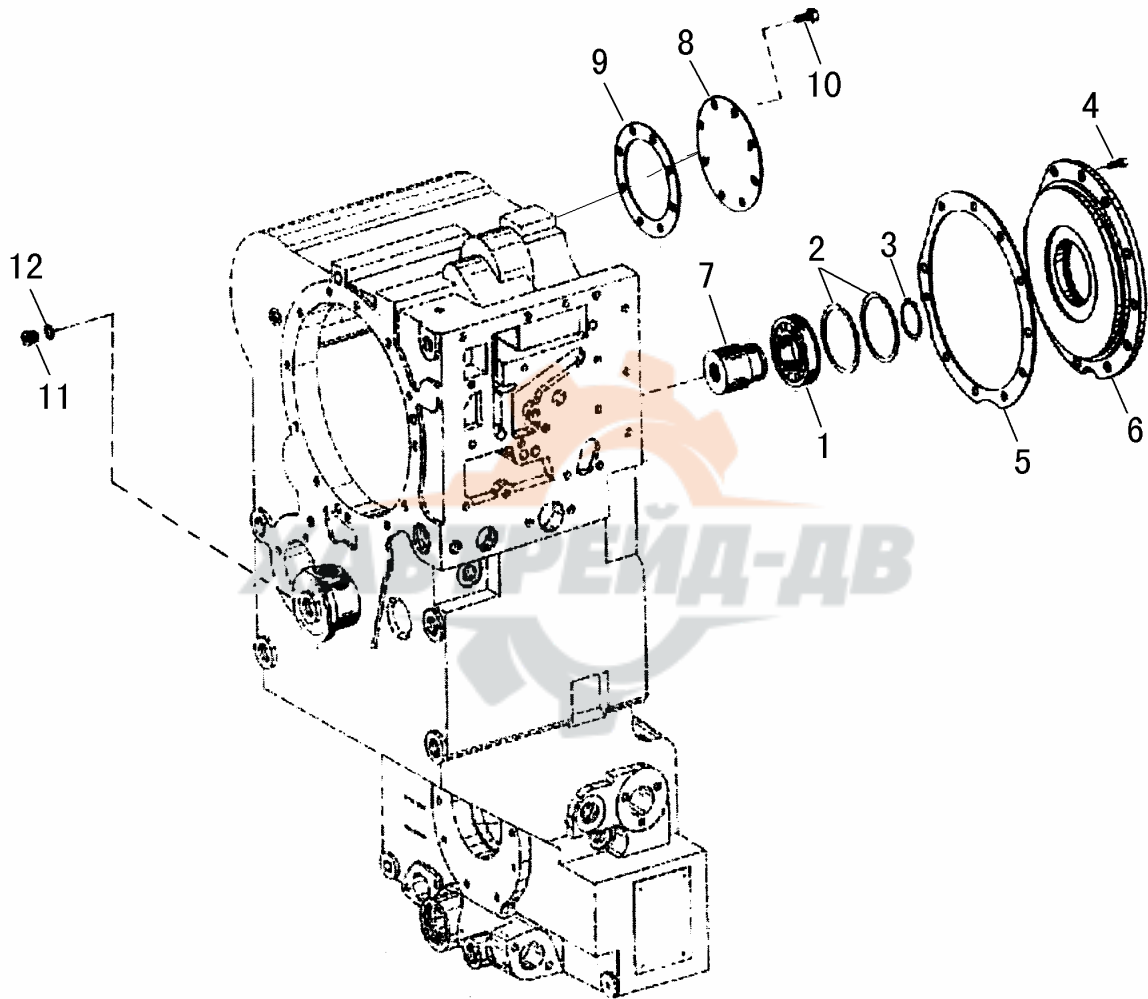

B15

序号	代号			数量	备注
KEY	PART NO.	DESCRIPTION		QTY	REMARKS
1	750116259	球轴承 6209N/C3	BALL BEARING 6209N/C3	2	
2	1630503011	柔性卡环 SP85	FLEXIBLE RETAINING RING SP85	1	
3	630501033	挡圈 45*1.75	RETAINING FOR SHAFT45*1.75	2	
4	GB/T5783-2000	螺栓 M8*20	BOLT M8*20	1	
5	YD13354008	法兰	PUMP FLANGE	1	
6	YD13354011	输出轴毂盘	P. T. O OUTPUT WHEEL HUB	12	
7	YD13354007	输出轴	P. T. O OUTPUT SHAFT	1	
8	YD13355006	端盖	END COVER	1	
9	YD13355004	衬垫	GASKET	1	
10	GB/T70. 1-2000	螺钉 M8*20	SCREW M8*20	7	
11	636305007	螺塞 AM14*1. 5	PLUG AM14*1. 5	1	
12	Q20-03	垫圈 14	WASHER 14	1	



B16

控制阀总成(II)

CONTROL VALVE ASSEMBLY(II)

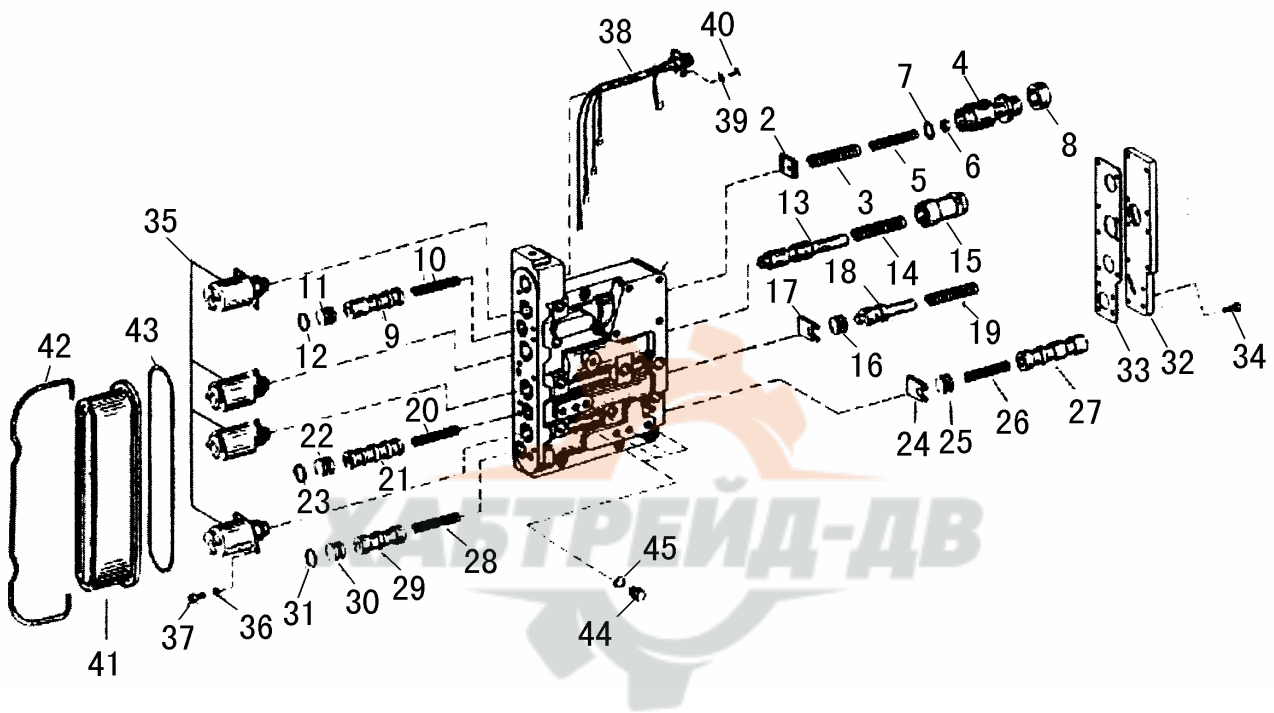

B16

序号	代号			数量	备注
KEY	PART NO.	DESCRIPTION		QTY	REMARKS
1	4642306152	阀体	VALVE BODY	1	
2	4620306248	衬垫	GASKET	1	
3	0732040838	螺钉 M8*20	SCREW M8*20	1	
4	4620306245	螺塞 AM14*1.5	PLUG AM14*1.5	1	
5	0732040837	垫圈 14	WASHER 14	1	
6	0730061778	接头螺套	SCREW-IN SLEEVE	1	
7	0769120747	垫片	SHIM	6	
8	4620306247	衬套	BUSHING	1	
9	4642306094	阀芯	VALVE CORE	1	
10	0732041254	弹簧	SPRING	1	
11	4620306252	挡销	BACKING PIN	1	
12	0634303118	O 形圈	O-RING	1	
13	4620306413	固定板	FIXING PLATE	1	
14	0732041390	阀芯	VALVE CORE	1	
15	4620306414	固定板	FIXING PLATE	1	
16	4644306549	阀芯	VALVE CORE	1	
17	4644306241	固定板	FIXING PLATE	1	
18	4620306255	阀芯	VALVE CORE	1	
19	0732041154	弹簧	SPRING	1	
20	0732041254	弹簧	SPRING	1	
21	4642306093	阀芯	VALVE CORE	1	
22	4620306252	挡销	BACKING PIN	1	
23	0634308118	O 形圈	O-RING	1	
24	4642306049	锁片	LOCKING PLATE	1	
25	4644306549	挡销	BACKING PIN	1	
26	0732041254	弹簧	SPRING	1	
27	4642306095	阀芯	VALVE CORE	1	
28	0732041254	弹簧	SPRING	1	
29	4642306096	阀芯	VALVE CORE	1	
30	4620306252	挡销	BACKING PIN	1	
31	0634303118	O 形圈	O-RING	1	
32	4620306415	盖	COVER	1	
33	4620306479	衬垫	GASKET	1	
34	0636015244	螺栓 M5*18	BOLT M5*18	11	
35	0501315338	电磁阀	SOLENOID VALVE	4	
36	0636101129	凸头螺栓 M5*12	SOCKET BOLT M5*12	8	
37	0630305012	弹性垫圈 5	SPRING WASHER 5	8	
38	4620206019	调整线圈	CABLE SET	1	
39	0636404299	凹槽螺钉 M4*12	SLOTTED SCREW M4*12	4	
40	0630302076	鞍形垫圈	SADDLE FLEXIBLE WASHER	4	
41	4620306259	电磁阀壳体	SOLENOID VALVE HOUSING	1	
42	0634303951	O 形圈	O-RING	1	
43	4620306241	喉箍	CLAMP	1	
44	0636304019	螺塞 M10*1	PLUG M10*1	6	
45	0634801152	铜垫圈 A10*13.5	COPPER WASHER A10*13.5	6	

C 驱动桥系统
AXLE SYSTEM



山东临工工程机械有限公司
SHANDONG LINGONG CONSTRUCTION MACHINERY LTD.

C1

驱动桥系统 AXLE SYSTEM

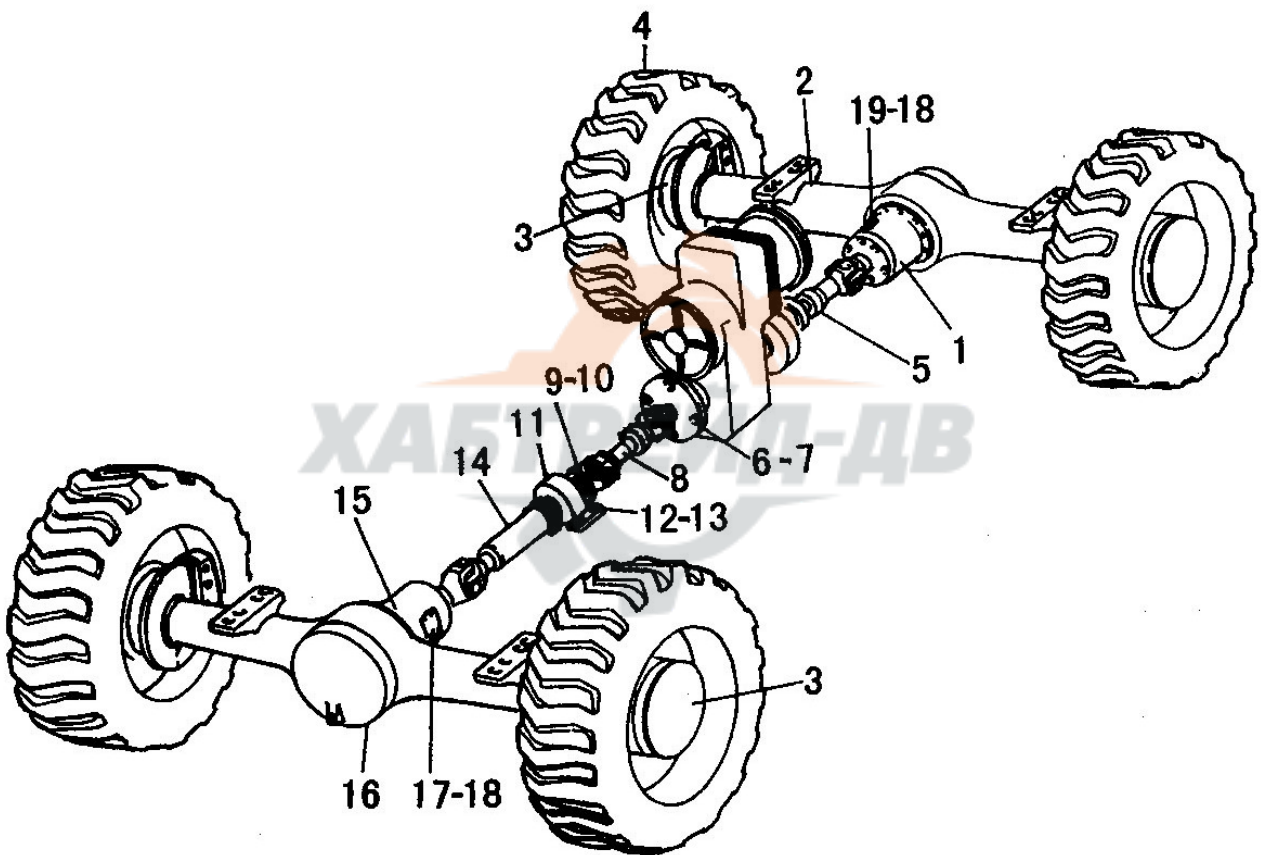

C1

序号	代号	名称		数量	备注
KEY	PART NO.	DESCRIPTION		QTY	REMARKS
1	2050900033	后主传动	REAR AXLE MAIN DRIVE ASS' Y	1	
2	2050900010	后桥壳总成	REAR AXLE ASS' Y	1	
3	2050900004	轮边减速器	FINAL DRIVE ASS' Y	1	
4	2050900005	轮辋	WHEEL FELLONE	4	
5	2908000766	后传动轴	REAR MOTION SHAFT	1	
6	3050900001	螺栓	BOLT	4	
7	3050900006	止动垫圈	WASHER	2	
8	2908000767	中间传动轴	MIDDLE MOTION SHAFT	1	
9	3050900002	螺栓	BOLT	20	
10	4013000180	螺母 GB889. 1-M14*1. 5EpZn-8	NUT GB889. 1-M14*1. 5EpZn-8	24	
11	2050900054	中间支承	HOLDER	1	
12	4011000241	螺栓 GB5785-M14*1. 5*55EpZn-8. 8	BOLT GB5785-M14*1. 5*55EpZn-8. 8	4	
13	4015000177	垫圈 GB97. 1-14-300HV	WASHER GB97. 1-14-300HV	4	
14	2050900055	前传动轴	FRONT MOTION SHAFT	1	
15	2050900006	前主传动	FRONT AXLE MAIN DRIVE ASS' Y	1	
16	2050900003	前桥壳总成	FRONT AXLE ASSEMBLY	1	
17	3050900005	前桥标牌	FRONT AXLE BRAND	1	
18	4019000012	铆钉 GB827-3*5-BL2	RIVET GB827-3*5-BL2	8	
19	3050900004	后桥标牌	REAR AXLE BRAND	1	

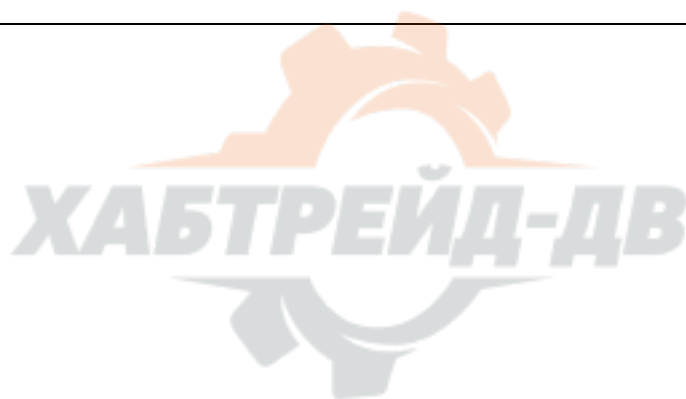

驱动桥总成
AXLE ASSEMBLY

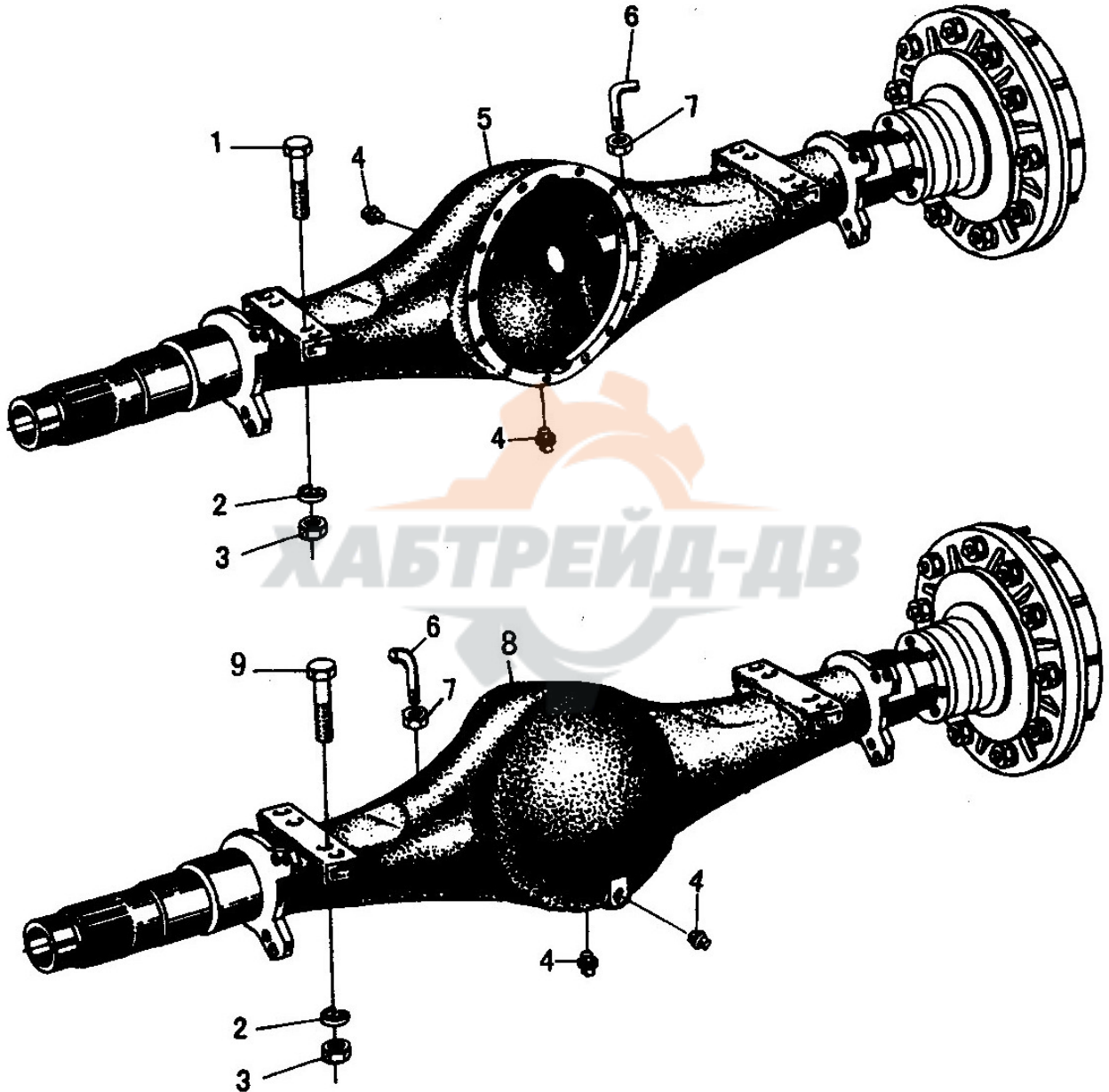

C2

序号	代号	名称		数量	备注
KEY	PART NO.	DESCRIPTION		QTY	REMARKS
1	4011000520	螺栓 GB5785-M24*2*100-8.8	BOLT	8	
2	4015000031	垫圈 GB93-24-65Mn	WASHER	16	
3	4013000157	螺母 GB889.2-M24*2-8	LOCKING NUT	16	
4	4120000080	螺塞 Q/ZB286-ZG3/4"-Q235A	PLUG	4	
5	2050900003	前桥壳总成	FRONT AXLE HOUSING	1	
6	2907000005	透气管	BREATHER PIPE	1	
7	4013000078	螺母 GB6173-M10*1EpZn-05	NUT	1	
8	2050900010	后桥壳总成	REAR AXLE HOUSING	1	
9	4011000521	螺栓 GB5785-M24*2*95-8.8	REAR AXLE BOLT	8	



前(后)主传动总成

FRONT (REAR) AXLE MAINDRIVE ASS'Y

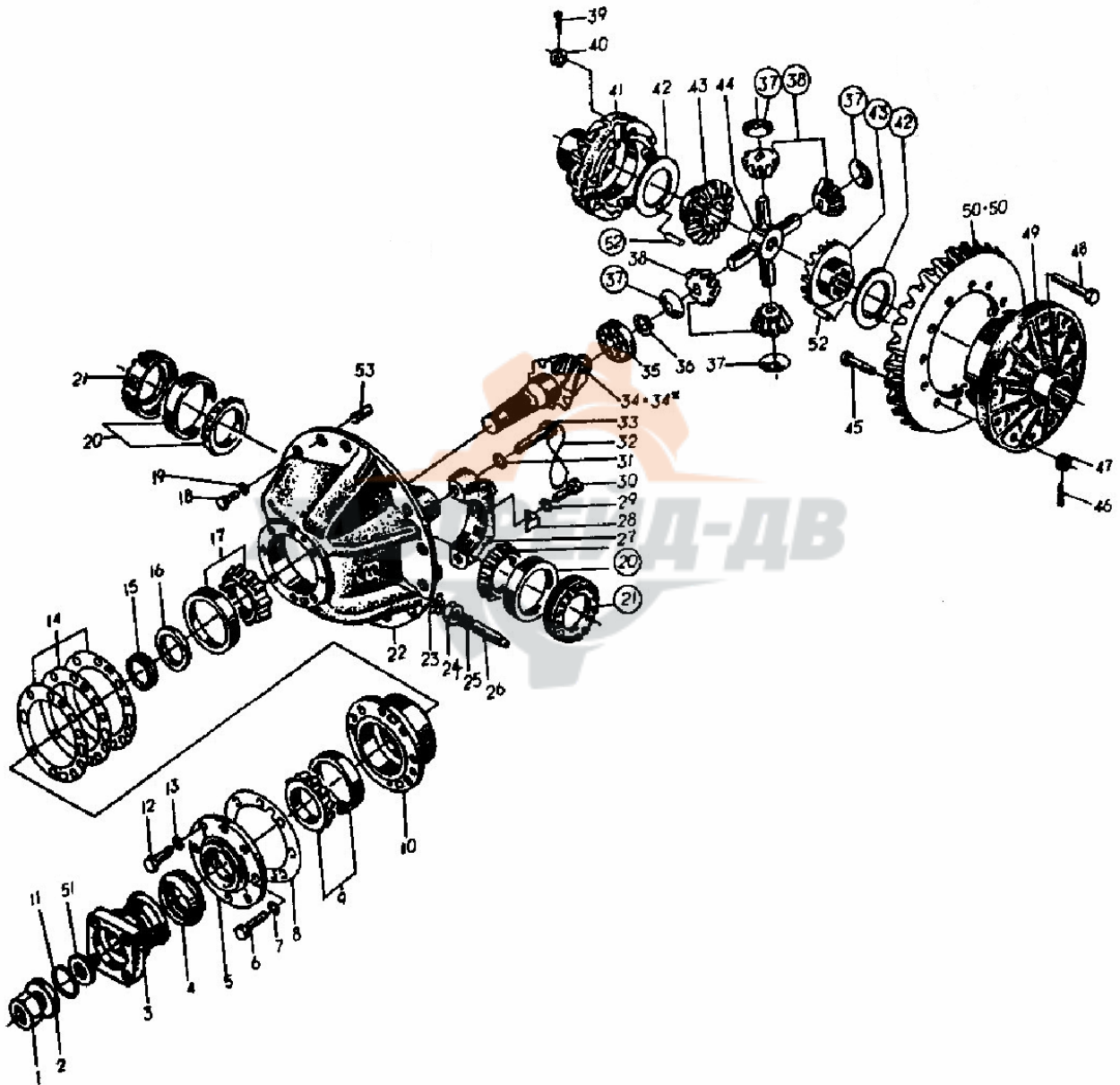

C3

序号	代号	名称		数量	备注
KEY	PART NO.	DESCRIPTION		QTY	REMARKS
1	4013000066	螺母 GB889. 2-M33*1. 5-8	NUT GB889. 2-M33*1. 5-8	1	
2	3050900007	垫圈	WASHER	1	
3	2050900011	输入法兰	INPUT PLANGE	1	
4	4030000048	骨架油封 HG4-692-SG70*95*12	SKELETON OIL SEAL HG4-692-SG70*95*12	1	
5	3050900009	密封盖	SEALING COVER	1	
6	4011000067	螺栓 GB5782-M14*55EpZn-8. 8	BOLT	7	
7	4015000027	垫圈 GB93-14-65Mn	WASHER	7	
8	3050900172	垫片	GASKET	1	
9	4021000028	滚动轴承 GB297-31310	BEARING	1	
10	3050900013	轴承套	BEARING SEAT	1	
11	3050900008	O型密封圈	O-RING	1	
12	4011000186	螺栓 GB5782-M12*55EpZn-8. 8	BOLT	1	
13	4015000026	垫圈 GB93-12-65Mn	WASHER	1	
14	3050900011	调整垫片	ADJUSTING SHIM	1	
15	3050900030	垫片	SPACER	1	
16	3050900012	轴套	SHAFT SLEEVE	1	
17	4021000029	滚动轴承 GB297-31311	BEARING	1	
18	4011000124	螺栓 GB5786-M12*1. 25*35EpZn-10. 9	BOLT	14	
19	4015000026	垫圈 GB93-12-65Mn	WASHER	14	
20	4021000035	滚动轴承 GB297-32215	BEARING	2	
21	3050900019	调整螺母	ADJUSTING NUT	2	
22	3050900016	托架	CARRIER	1	
23	3050900080	锁紧片	LOCKING SHIM	1	
24	4013000052	螺母 GB6173-M27*2-05	NUT	1	
25	3050900102	铜套	COPPER SLEEVE	1	
26	3050900101	螺栓	BOLT	1	
27	3050900023	轴承座	BEARING SEAT	1	
28	3050900024	锁紧片	LOCKING LEAF	2	
29	4015000025	垫圈 GB93-10-65Mn	WASHER	2	
30	4011000009	螺栓 GB32. 3-M10*1*20-8. 8	BOLT	2	
31	4015000184	垫圈 GB97. 1-22EpZn-300HV	WASHER	4	
32	4090000014	低碳钢丝 GB343-1. 6*450	STEEL WIRE	2	
33	4011000332	螺栓 GB32. 1-M22*80EpZn-8. 8	BOLT	4	
34	3050900015	主动螺旋伞齿轮(右)	SPIRAL BEVELGEAR PINION(RIGHT)	1	
34*	3050900055	主动螺旋伞齿轮(左)	SPIRAL BEVELGEAR PINION(LEFT)	1	
35	4021000026	滚动轴承 GB283-NUP2306	BEARING NUP	1	
36	4015000019	挡圈 GB894. 1-30-65Mn	RING SNAP	1	
37	3050900017	锥齿轮垫片	WASHER	4	
38	3050900018	锥齿轮	PINION FOR DIFFERENTIAL	4	
39	4016000123	开口销 GB91-3. 2*28	SPLIT PIN	8	
40	4013000154	螺母 GB6178-M14-8	NUT	8	
41	3050900020	差速器左壳	LEFT CASE DIFF	1	
42	3050900022	半轴齿轮垫片	WSGER THRUST	2	
43	3050900021	半轴齿轮	AXLE SHAFT GAER	2	
44	3050900026	十字轴	CARDAN SHAFT	1	
45	3050900028	螺栓	BOLT	12	
46	4016000122	开口销 GB91-4*28EpZn-Q235A	SPLIT PIN	12	
47	4013000155	螺母 GB6178-M16-10	NUT	12	
48	3050900025	螺栓	BOLT	8	
49	3050900027	差速器右壳	RIGHT CASE DIFF	1	
50	3050900029	大螺旋伞齿轮	SPIRAL BEVEL DRIVEN GEAR(LEFT)	1	
50*	3050900056	大螺旋伞齿轮	SPIRAL BEVEL DRIVEN GEAR(RIGHT)	1	
51	3050900032	挡圈	RING SNAP	1	
52	2907000046	固定销	FIXED PIN	1	
53	4016000124	固定销 10u8×30	FIXED PIN 10u8×30	2	

C4

轮边减速器总成

FINAL DRIVE ASSEMBLY

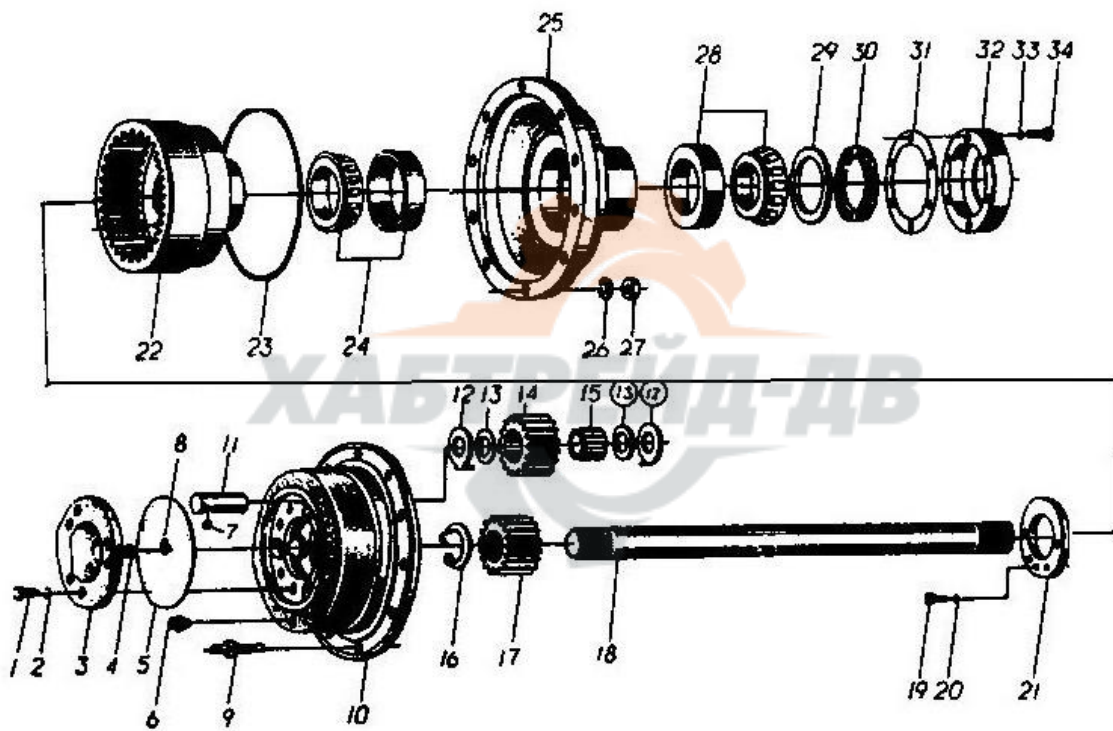

C4

序号	代号	名称		数量	备注
KEY	PART NO.	DESCRIPTION		QTY	REMARKS
1	4011000084	螺栓 GB5783-M10*30EpZn-8.8	BOLT	10	
2	4015000026	垫圈 GB93-12-65Mn	WASHER	10	
3	2907000767	盖	COVER	1	
4	2907000916	定位块	LOCK BLOCK	1	
5	2907000768	O型密封圈	O-RING	1	
6	4120000080	螺塞 Q/ZB286-ZG3/4"-Q235A	PLUG	1	
7	4090000007	钢球 GB308-8-GCr15	STEEL BALL	3	
8	4090000006	钢球 GB308-171462-GCr15	STEEL BALL	1	
9	3050900044	轮辋螺栓	RIM BOLT	10	
10	2907000766	行星轮架	CARRIER OF PLANT GEAR	1	
11	3050900043	行星齿轮轴	PLANT GEAR SPINDLE	3	
12	3050900052	垫片	SPACER	6	
13	3050900042	挡环	RING SNAP	6	
14	3050900041	行星齿轮	PLANET GEAR	3	
15	4090000003	滚针 GB309-4*38-GCr15	ROLLER	93	
16	4015000046	挡圈 GB894.1-50-65Mn	RING SNAP GB894.1-50-65Mn	1	
17	3050900040	太阳轮	GEAR-SUN	1	
18	3050900050	半轴	DIFFERENTIAL AXLE	1	
19	4014000118	螺钉 GB70-M8*1*20-8.8	SCREW GB70-M8*1*20-8.8	1	
20	4015000036	垫圈 GB93-8-65Mn	WASHER	1	
21	3050900047	圆螺母	ROUND NUT	1	
22	3050900037	内齿轮	AXLE RING GEAR	1	
23	3050900045	O形圈	O-RING	1	
24	4021000044	滚动轴承 GB297-32220	ROLLING BEARING GB297-32220	1	
25	3050900046	轮毂	HUB WHEEL	1	
26	4015000029	垫圈 GB93-18-65Mn	WASHER GB93-18-65Mn	10	
27	4013000136	螺母 GB6171-M18*1.5EpZn-8	NUT GB6171-M18*1.5EpZn-8	10	
28	4021000045	滚动轴承 GB297-32021	ROLLING BEARING GB297-32021	1	
29	3050900051	轴承隔套	BEARING COWL	1	
30	4030000046	骨架油封 HG4-692-PD130*160*12	FRAME OIL SEAL	1	
31	3050900048	垫片	BACKUP PLATE	1	
32	3050900049	油封端盖	OIL SEAL COVER	1	
33	4015000036	垫圈 GB93-8-65Mn	WASHER GB93-8-65Mn	1	
34	4011000195	螺栓 GB5783-M8*35EpZn-8.8	BOLT GB5783-M8*35EpZn-8.8	6	

轮胎轮辋总成 RIM AND TYRE ASSEMBLY

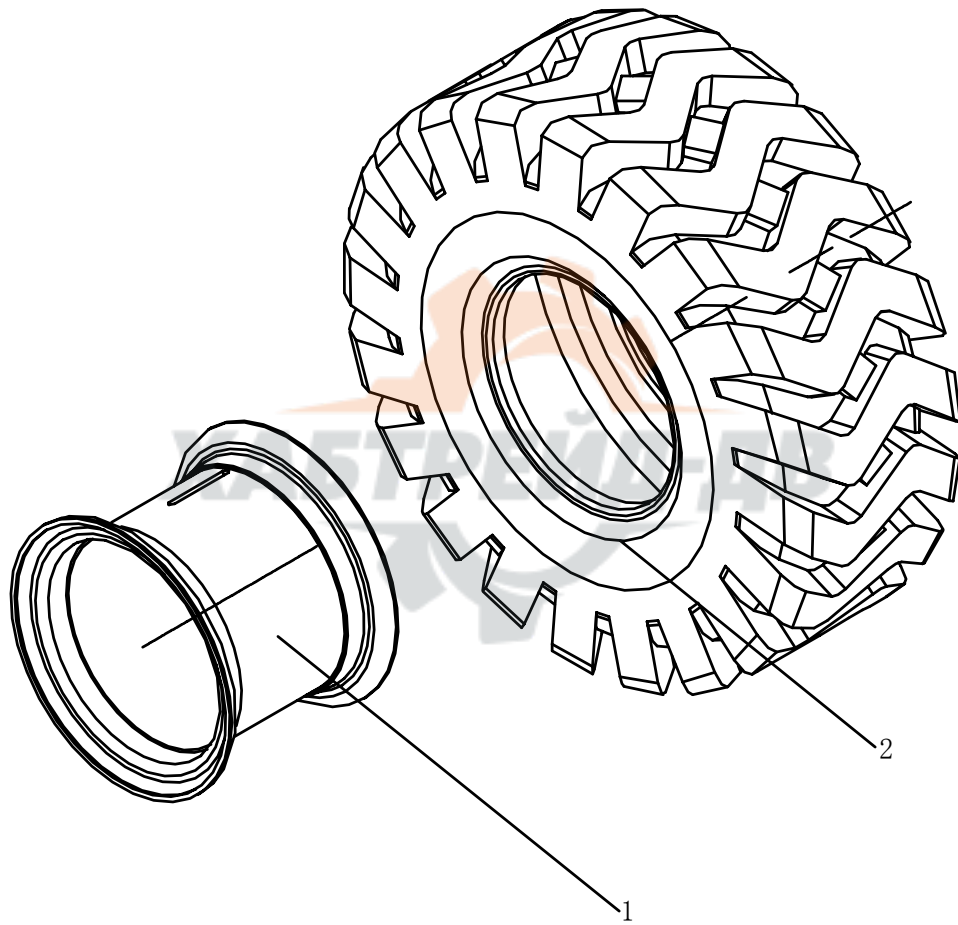

C5

序号	代号	名称	数量	备注
KEY	PART NO.	DESCRIPTION	QTY	REMARKS
1	2050900005	轮辋	4	RIM
2	4110000003	轮胎 GB2980-17.5-25	4	TIRE ASS' Y



D 工作装置液压系统
IMPLEMENT HYDRAULIC SYSTEM



山东临工工程机械有限公司
SHANDONG LINGONG CONSTRUCTION MACHINERY LTD.

D1

工作装置液压系统 IMPLEMENT HYDRAULIC SYSTEM

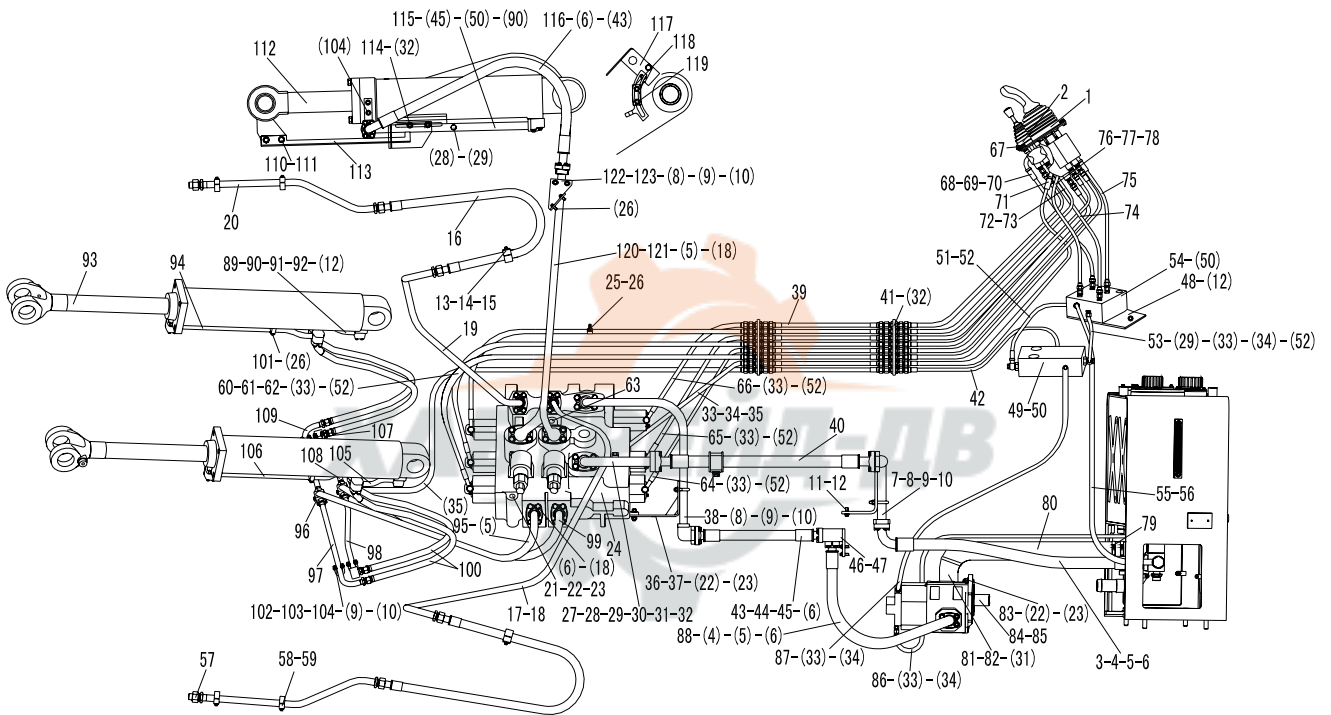

D1

序号	代号	名称		数量	备注
KEY	PART NO.	DESCRIPTION		QTY	REMARKS
1	4120000370	单手柄先导阀总成 DXS-00	MONOLEVER PILOT VALVE DXS-00	1	部件
2	4120001074	先导阀总成 HC-RCM/1	PILOT VALVE HC-RCM/1	1	部件
3	4041000532	软管 LGB162-012105	PIPE LGB162-012105	1	部件
4	4041000056	分体法兰 LGB117-312550	FLANGE LGB117-312550	6	
5	4030000029	O形圈 GB3452.1-37.5*3.55G	O-RING GB3452.1-37.5*3.55G	12	
6	4011000475	螺栓 GB16674-M10*30EpZn-8.8	BOLT GB16674-M10*30EpZn-8.8	88	
7	2912000403	回油钢管	OIL RETURN TUBE	1	部件
8	4011000556	U形螺栓 JB/ZQ4321-33Zn-Q235A.F	U-BOLT JB/ZQ4321-33Zn-Q235A.F	4	
9	4013000007	螺母 GB6170-M10EpZn-8	NUT GB6170-M10EpZn-8	16	
10	4015000162	垫圈 GB97.1-10EpZn-300HV	WASHER GB97.1-10EpZn-300HV	16	
11	2912001137	固定板	MOUNTED PLATE	1	Q235A
12	4011000447	螺栓 GB16674-M10*20EpZn-8.8	BOLT GB16674-M10*20EpZn-8.8	6	
13	4011000172	螺栓 GB16674-M8*50EpZn-8.8	BOLT GB16674-M8*50EpZn-8.8	4	
14	2912001159	压板	PRESS PLATE	2	Q235A
15	2912001160	橡胶管夹	RUBBER PIPE CLIP	4	氯丁橡胶
16	4041000719	软管 LGB127-012160	PIPE LGB127-012160	2	部件
17	2912001156	辅助联左钢管	ASSISTANT JOIN LEFT STEEL TUBE	1	部件
18	4041000027	分体法兰 LGB117-312551	FLANGE LGB117-312551	6	部件
19	2912001157	辅助联右钢管	ASSISTANT JOIN RIGHT STEEL TUBE	1	部件
20	2912001158	动臂钢管	TUBE OF LIFT CYLINDER	2	
21	4011000057	螺栓 GB5782-M12*165EpZn-8.8	BOLT GB5782-M12*165EpZn-8.8	2	
22	4015000168	垫圈 GB97.1-12EpZn-300HV	WASHER GB97.1-12EpZn-300HV	9	
23	4013000011	螺母 GB6170-M12EpZn-8	NUT GB6170-M12EpZn-8	9	
24	4120001054	多路阀 D32A-16	MULTIPLE UNIT VALVE D32A-16	1	部件
25	2912000767	管夹	PIPE CLIP	4	部件
26	4011000458	螺栓 GB16674-M8*20EpZn-8.8	BOLT GB16674-M8*20EpZn-8.8	14	
27	2912001063	多路阀回油钢管	OIL RETURN TUBE OF MULTIPLE UNIT VALVE	1	部件
28	4041000774	螺塞 LGB135-01422	PLUG SCREW LGB135-01422	5	
29	4041000767	O形圈 LGB168-11124	O-RING LGB168-11124	7	
30	4041000010	分体法兰 LGB117-314651	FLANGE LGB117-314651	2	
31	4030000130	O形圈 GB3452.1-47.5*3.55G	O-RING GB3452.1-47.5*3.55G	3	
32	4011000479	螺栓 GB16674-M12*30EpZn-8.8	BOLT GB16674-M12*30EpZn-8.8	16	
33	4030000057	垫圈 JB1002-14-T2	WASHER JB1002-14-T2	29	
34	2912000992	直通接头	STRAIGHT COUPLING	12	
35	4041000632	软管 LGB125-004080	PIPE LGB125-004080	2	部件
36	4011000477	螺栓 GB16674-M12*35EpZn-8.8	BOLT GB16674-M12*35EpZn-8.8	2	
37	2912001139	固定支架	STEADY REST	1	部件
38	2912001069	多路阀进油钢管	FEEDING TUBE OF MULTIPLE UNIT VALVE	1	部件
39	2912001072	中部先导油管	MIDDLE PILOT PIPE	8	部件
40	4041000636	软管 LGB163-012080	PIPE LGB163-012080	1	部件
41	2912001073	二通管组	TWO-WAY NEST OF TUBES	2	部件
42	4041000613	软管 LGB124-004080	PIPE LGB124-004080	1	部件
43	4041000043	分体法兰 LGB117-310490	FLANGE LGB117-310490	6	
44	4041000642	软管 LGB107-010112	PIPE LGB107-010112	1	部件
45	4030000026	O形圈 GB3452.1-32.5*3.55G	O-RING GB3452.1-32.5*3.55G	7	
46	2912001075	二通块	TWO-WAY BLOCK	1	部件
47	4011000455	螺栓 GB16674-M8*25EpZn-8.8	BOLT GB16674-M8*25EpZn-8.8	4	
48	2912001077	固定板	MOUNTED PLATE	1	Q235A
49	4120000448	压力选择阀 SF8-C	PRESSURE SELECTOR VALVE SF8-C	1	部件
50	4011000473	螺栓 GB16674-M10*55EpZn-8.8	BOLT GB16674-M10*55EpZn-8.8	6	
51	2912001147	选择阀回油管	RETURN PIPE OF SELECTOR VALVE	1	部件
52	4011000344	螺栓 JB999-M14*1.5*32-35	BOLT JB999-M14*1.5*32-35	12	
53	2912001029	选择阀至过渡块软管	PIPE FROM SELECTOR VALVE TO TRANSITION BLOCK	1	部件
54	2912001079	过渡块	TRANSITION BLOCK	1	35

D1

工作装置液压系统 IMPLEMENT HYDRAULIC SYSTEM

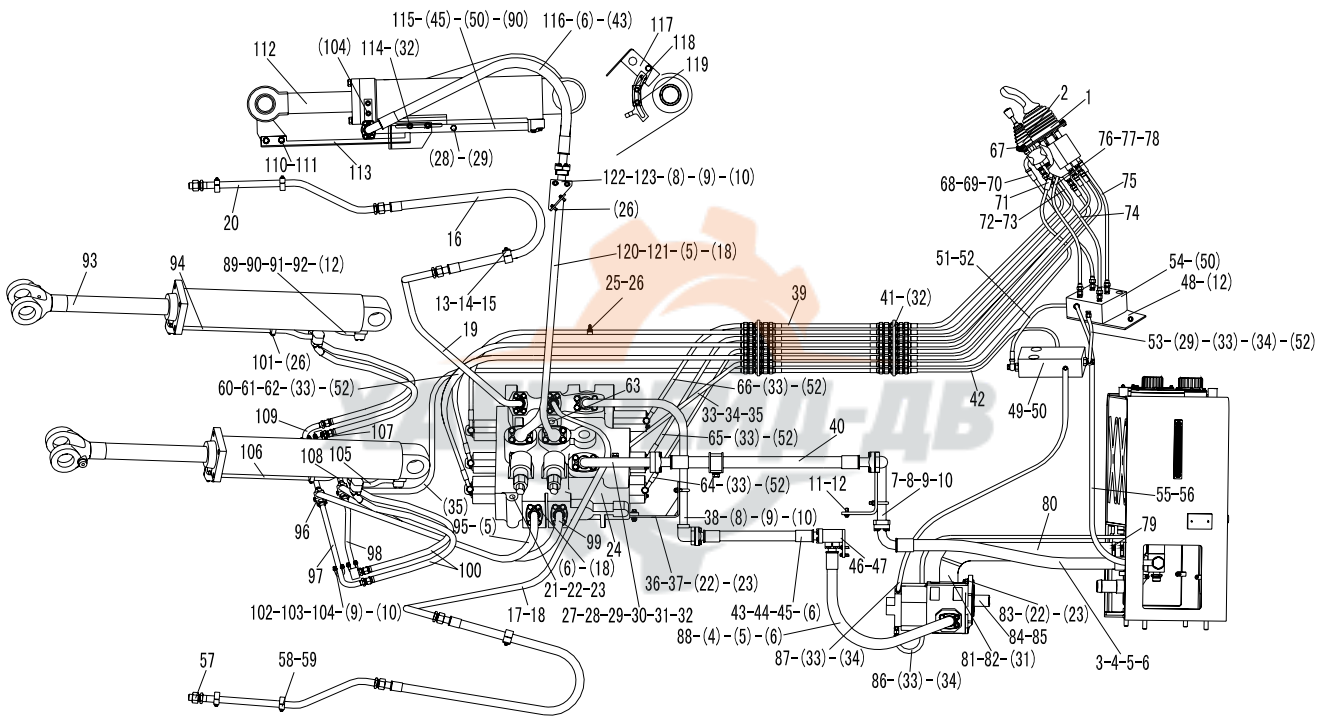

D1

序号	代号	名称		数量	备注
KEY	PART NO.	DESCRIPTION		QTY	REMARKS
55	2912001080	过渡块回油管	RETURN PIPE OF TRANSITION BLOCK	1	部件
56	4041000150	直接头 LGB120-01814	STRAIGHT JOINT LGB120-01814	2	
57	4041000708	堵塞 LGB142-03016	BLOCKING LGB142-03016	2	部件
58	2912001081	压板	PRESS PLATE	4	
59	4011000161	螺栓 GB16674-M8*35EpZn-8.8	BOLT GB16674-M8*35EpZn-8.8	8	
60	2912001082	前部先导油管 (a2)	FRONT PILOT PTPE (a2)	1	
61	2912001083	前部先导油管 (a1)	FRONT PILOT PTPE (a1)	1	
62	2912001084	前部先导油管 (a3)	FRONT PILOT PTPE (a3)	1	
63	4011000056	螺栓 GB5782-M12*145EpZn-8.8	BOLT GB5782-M12*145EpZn-8.8	1	
64	2912001085	前部先导油管 (b2)	FRONT PILOT PTPE (b2)	1	部件
65	2912001086	前部先导油管 (b1)	FRONT PILOT PTPE (b1)	1	部件
66	2912001088	前部先导油管 (b3)	FRONT PILOT PTPE (b3)	1	部件
67	4011000153	螺栓 GB16674-M6*16EpZn-8.8	BOLT GB16674-M6*16EpZn-8.8	4	
68	2912001032	螺栓	BOLT	2	35
69	2912001148	先导阀回油胶管	RETURN PIPE OF PILOT VALVE	1	部件
70	4015000121	垫圈 JB982-14	WASHER JB982-14	4	
71	2912001089	先导阀油管 (2c)	PIPE OF PILOT VALVE (2c)	1	部件
72	4041000641	软管 LGB124-004150	PIPE LGB124-004150	6	部件
73	2912001034	直通接头	STRAIGHT COUPLING	2	
74	2912001149	先导阀进油胶管	FEEDING HOSE OF PILOT VALVE	1	部件
75	2912001090	先导阀进油胶管	FEEDING HOSE OF PILOT VALVE	1	部件
76	2912001091	先导阀回油胶管	RETURN HOSE OF PILOT VALVE	1	部件
77	4030000058	垫圈 JB1002-18-T2	WASHER JB1002-18-T2	2	
78	4011000366	螺栓 JB999-M18*1.5*40-35	BOLT JB999-M18*1.5*40-35	1	
79	4017000013	喉箍 JB8870-d90	ADMAS APPLE JB8870-d90	4	
80	2911000808	双联泵吸油胶管	INLET HOSE OF TWO-WAY FLOW PUMP	1	部件
81	2911000809	双联泵吸油钢管	INLET TUBE OF TWO-WAY FLOW PUMP	1	部件
82	4011000337	螺栓 GB16674-M12*60EpZn-8.8	BOLT GB16674-M12*60EpZn-8.8	4	
83	4012000003	螺柱 GB898-M12*35EpZn-8.8	DOUBLE-SCREW BOLT GB898-M12*35EpZn-8.8	4	
84	4120001059	双联泵 CBGj3100/1010C-XF	TWO-WAY FLOW PUMP CBGj3100/1010C-XF	1	
85	2911000004	泵用密封垫	SEALING PLATE OF PUMP	1	耐油石棉橡胶板
86	4041000645	软管 LGB165-004130	PIPE LGB165-004130	1	
87	4041000646	软管 LGB165-004070	PIPE LGB165-004070	1	
88	2911000810	双联泵出油胶管	OUTLET HOSE OF TWO-WAY FLOW PUMP	1	
89	2913000412	右动臂缸大腔钢管	BIG CHAMBER TUBE OF RIGHT LIFTING CYLINDER	1	部件
90	4030000279	O形圈 GB3452.1-25*3.55G	O-RING GB3452.1-25*3.55G	8	
91	4011000309	螺栓 GB16674-M10*50EpZn-8.8	BOLT GB16674-M10*50EpZn-8.8	10	
92	4011000164	螺栓 GB16674-M10*35EpZn-8.8	BOLT GB16674-M10*35EpZn-8.8	8	
93	4120000867	动臂油缸 HSGF-125*70*771-1240	LIFTING CYLINDER HSGF-125*70*771-1240	2	
94	2913000413	右动臂缸小腔钢管	SMALL CHAMBER TUBE OF RIGHT LIFTING CYLINDER	1	部件
95	2913000830	动臂联小腔三通钢管	SMALL CHAMBER THREE-WAY TUBE OF LIFTING CYLINDER	1	部件
96	4041000137	分体法兰 LGB117-306400	FLANGE LGB117-306400	4	
97	2913000831	阀至左动臂缸小腔钢管	FROM VALVE TO LEFT LIFTING CYLINDER SMALL CHAMBER TUBE	1	部件
98	2913000832	阀至左动臂缸大腔钢管	FROM VALVE TO LEFT LIFTING CYLINDER BIG CHAMBER TUBE	1	部件
99	2913000835	动臂联大腔三通钢管	BIG CHAMBER THREE-WAY TUBE OF LIFTING CYLINDER	1	部件
100	2913000895	动臂缸胶管	LIFTING CYLINDER HOSE	4	部件
101	2913000408	管夹	PIPE CLIP	2	Q235A
102	4011000490	U形螺栓 JB/ZQ4321-25Zn-Q235A·F	U-BOLT JB/ZQ4321-25Zn-Q235A·F	4	
103	2913000409	固定支架 A	STEADY REST A	1	
104	4011000488	螺栓 GB16674-M10*16EpZn-8.8	BOLT GB16674-M10*16EpZn-8.8	8	
105	2913000407	左动臂缸大腔钢管	BIG CHAMBER TUBE OF LEFT LIFTING CYLINDER	1	部件
106	2913000402	左动臂缸小腔钢管	SMALL CHAMBER TUBE OF LEFT LIFTING CYLINDER	1	部件
107	2913000411	固定支架 B	STEADY REST B	1	部件
108	2913000833	阀至右动臂缸大腔钢管	FROM VALVE TO RIGHT LIFTING CYLINDER BIG CHAMBER TUBE	1	部件

D1

工作装置液压系统 IMPLEMENT HYDRAULIC SYSTEM

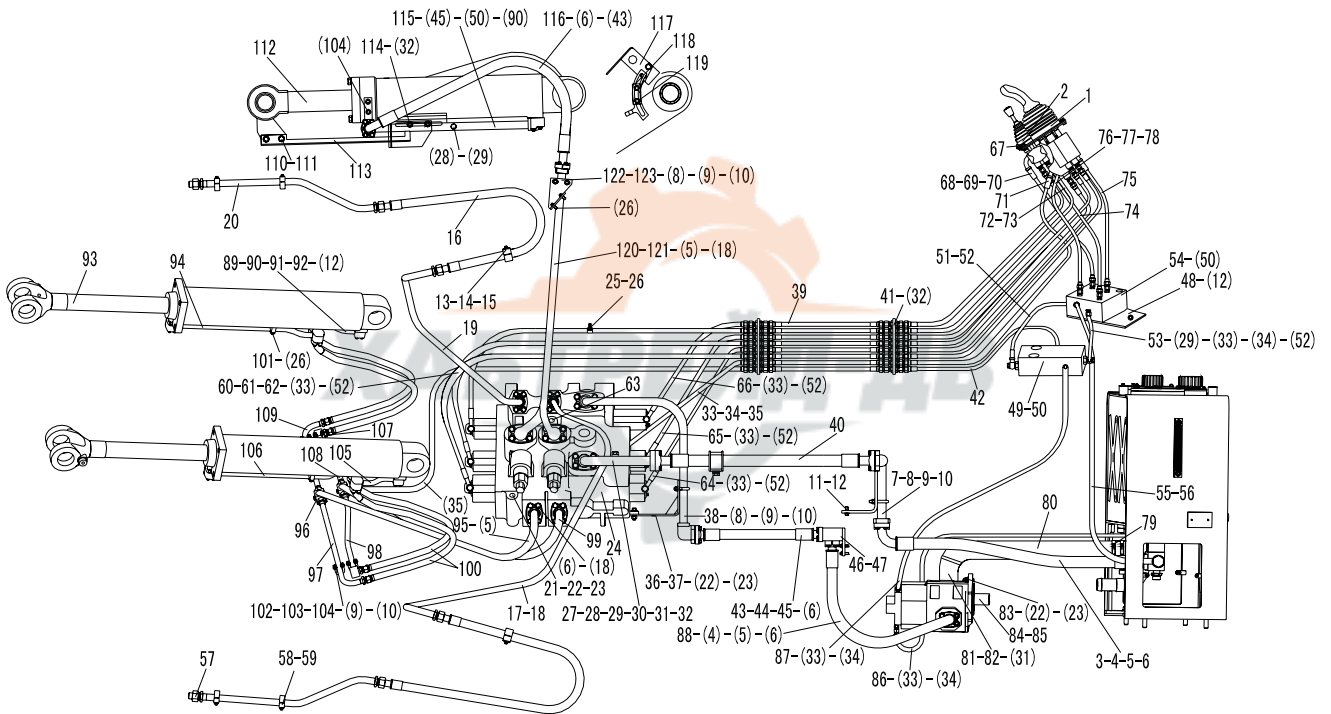

D1

序号	代号	名称		数量	备注
KEY	PART NO.	DESCRIPTION		QTY	REMARKS
109	2913000834	阀至右动臂缸小腔钢管	FROM VALVE TO RIGHT LIFTING CYLINDER SMALL CHAMBER TUBE	1	部件
110	4011000145	螺栓 GB16674-M14*35EpZn-8.8	BOLT GB16674-M14*35EpZn-8.8	2	
111	4013000013	螺母 GB6170-M14EpZn-8	NUT GB6170-M14EpZn-8	2	
112	4120001083	转斗油缸 HSGF-140*80*502-952P	TILT CYLINDER HSGF-140*80*502-952P	1	
113	2914000837	转斗指示板	INDICATING PLATE OF TILTING CYLINDER	1	Q235A
114	2914000758	接近开关支架	FRAME OF ADJACENT SWITCH	1	部件
115	2914000844	转斗缸大腔钢管	BIG CHAMBER TUBE OF TILT CYLINDER	1	部件
116	4041000703	软管 LGB106-010120	PIPE LGB106-010120	2	
117	2914000754	接近开关支架	FRAME OF ADJACENT SWITCH	1	部件
118	2914000755	动臂指示板	INDICATING PLATE OF LIFTING CYLINDER	1	Q235A
119	4011000137	螺栓 GB16674-M12*20EpZn-8.8	BOLT GB16674-M12*20EpZn-8.8	4	
120	2914000840	转斗联小腔钢管	SMALL CHAMBER TUBE OF TILT CYLINDER	1	部件
121	2914000841	转斗联大腔钢管	BIG CHAMBER TUBE OF TILT CYLINDER	1	部件
122	2914000406	固定支架 A	STEADY REST A	1	部件
123	2914000407	固定支架 B	STEADY REST B	1	部件



D2

快换装置液压系统

QUICK COUPLING EQUIPMENT HYDRAULIC SYSTEM

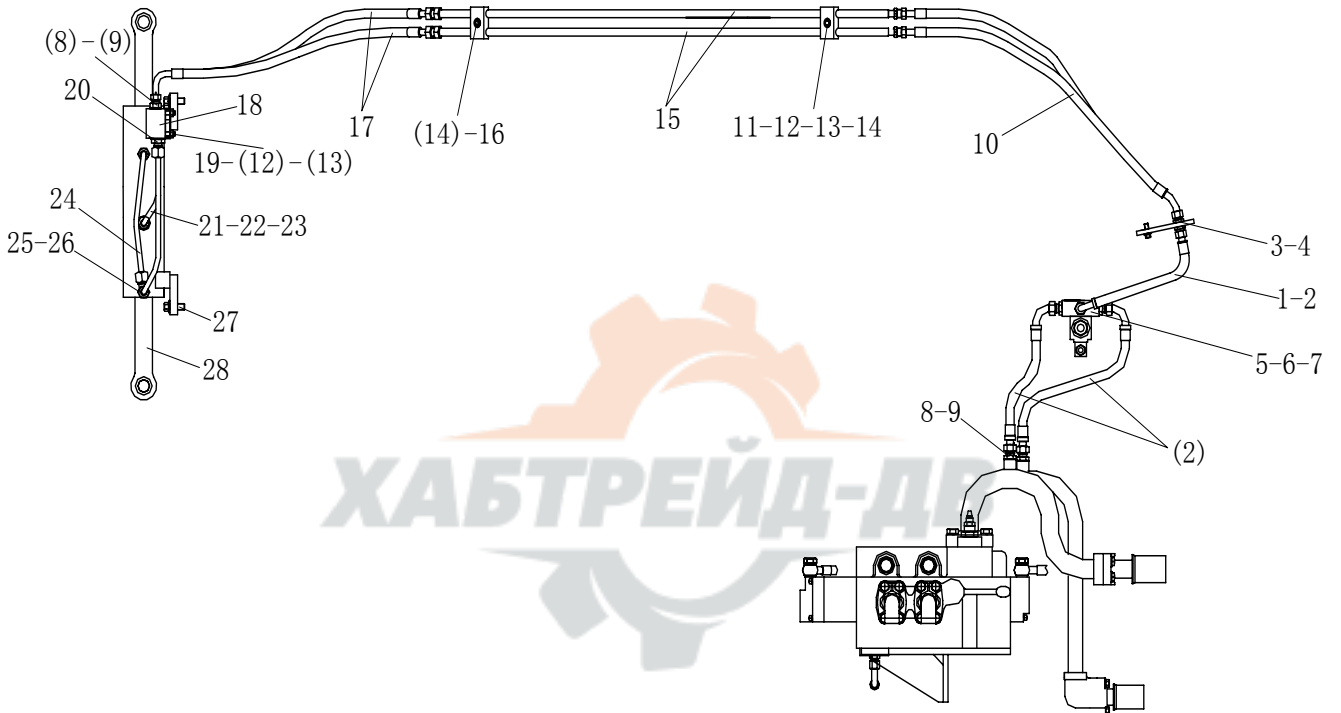

D2

序号	代号	名称		数量	备注
KEY	PART NO.	DESCRIPTION		QTY	REMARKS
1	4041000626	软管 LGB128-004045	PIPE LGB128-004045	1	
2	4041000627	软管 LGB128-004055	PIPE LGB128-004055	3	
3	2912001007	隔板接头	DUMMY PLATE JOINT	2	35
4	4013000123	螺母 GB6173-M16*1.5EpZn-05	NUT GB6173-M16*1.5EpZn-05	2	
5	4120000368	电磁换向阀 4WE6E61B/CG24NZ4B08	SOLENOID DIRECTIONAL VALVE 4WE6E61B/CG24NZ4B08	1	
6	4011000448	螺钉 GB70.1-M8*30EpZn-8.8	SCREW GB70.1-M8*30EpZn-8.8	4	
7	2918000786	电磁阀座	SOLENOID VALVE SEAT	1	35
8	4041000604	直接头 LGB120-01614	JOINT LGB120-01614	8	
9	4030000057	垫圈 JB1002-14-T2	WASHER JB1002-14-T2	10	
10	4041000628	软管 LGB129-004085	PIPE LGB129-004085	2	
11	4011000298	螺栓 GB5782-M8*45EpZn-8.8	BOLT GB5782-M8*45EpZn-8.8	1	
12	4013000033	螺母 GB6170-M8EpZn-8	NUT GB6170-M8EpZn-8	3	
13	4015000072	垫圈 GB97.1-8EpZn-300HV	WASHER GB97.1-8EpZn-300HV	3	
14	2918000796	固定压板	MOUNTING PRESS PLATE	2	Q235A
15	2918000813	快换联钢管	QUICK-CHANGE UNITE TUE	2	部件
16	4011000455	螺栓 GB16674-M8*25EpZn-8.8	BOLT GB16674-M8*25EpZn-8.8	1	
17	4041000629	软管 LGB128-204140	PIPE LGB128-204140	2	
18	4120000507	液压锁 BQ2201-7A	FLUIDPOWER LOCK BQ2201-7A	1	
19	4014000119	螺钉 GB70.1-M8*55EpZn-8.8	SCREW GB70.1-M8*55EpZn-8.8	2	
20	2918000800	直接头	JOINT	2	35
21	2918000801	液压锁至油缸大腔油管	OIL TUBE (BIG)	1	部件
22	2918000804	接头体	JOINT BODY	3	35
23	4030000058	垫圈 JB1002-18-T2	WASHER JB1002-18-T2	3	
24	2918000805	中部连接油管	MIDDLE OIL TUBE	1	部件
25	2918000807	液压锁至油缸小腔油管	OIL TUBE (SMALL)	1	部件
26	2918000809	三通接头体	TEE BEND JOINT BODY	1	部件
27	4011000479	螺栓 GB16674-M12*30EpZn-8.8	BOLT GB16674-M12*30EpZn-8.8	4	
28	4120000326	双杆液压缸 HSGL-60*35*55-ZLK30F2	FLUID CYLINDER HSGL-60*35*55-ZLK30F2	1	

D3

转斗油缸 DUMP CYLINDER

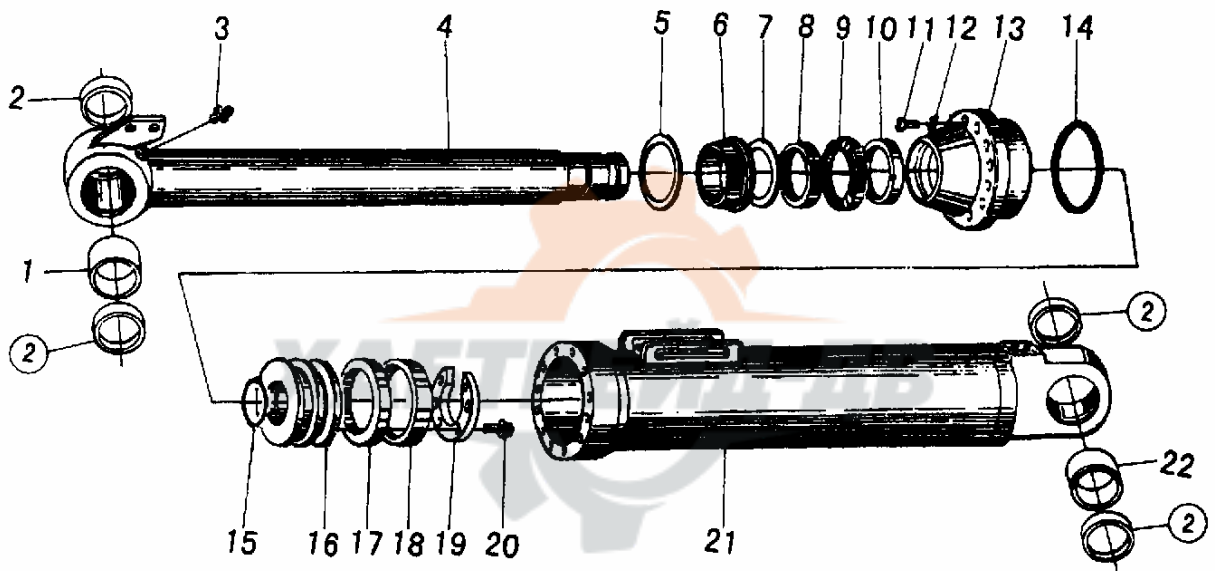

D3

序号	代号	名称		数量	备注
KEY	PART NO.	DESCRIPTION		QTY	REMARKS
1		衬套	BUSHING	1	
2		防尘圈	DUST PROOF RING	4	
3		油杯	FITTING	1	
4		活塞杆	PISTON ROD	1	
5		卡环	LOCK RING	1	
6		防尘圈	DUST PROOF RING	1	
7		挡圈	SNAP RING	1	
8		U形圈	U-RING	1	
9		缓冲环	CUSHION RING	1	
10		支撑环	SUPPORTING RING	1	
11		螺栓	BOLT	12	
12		垫圈	WASHER	12	
13		缸盖	CYLINDER COVER	1	
14		O形圈	O-RING	1	
15		O形圈	O-RING	1	
16		活塞	PISTON	1	
17		组合封	FABRICATE SEALING	1	
18		支撑环	SUPPORTING RING	1	
19		挡块	HOLDING BLOCK	1	
20		螺栓	BOLT	6	
21		缸体	CYLINDER BODY	1	
22		衬套	BUSHING	1	

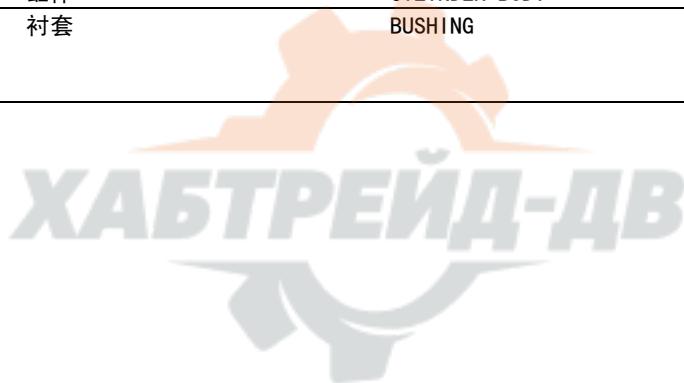

D4

动臂油缸 LIFT ARM CYLINDER

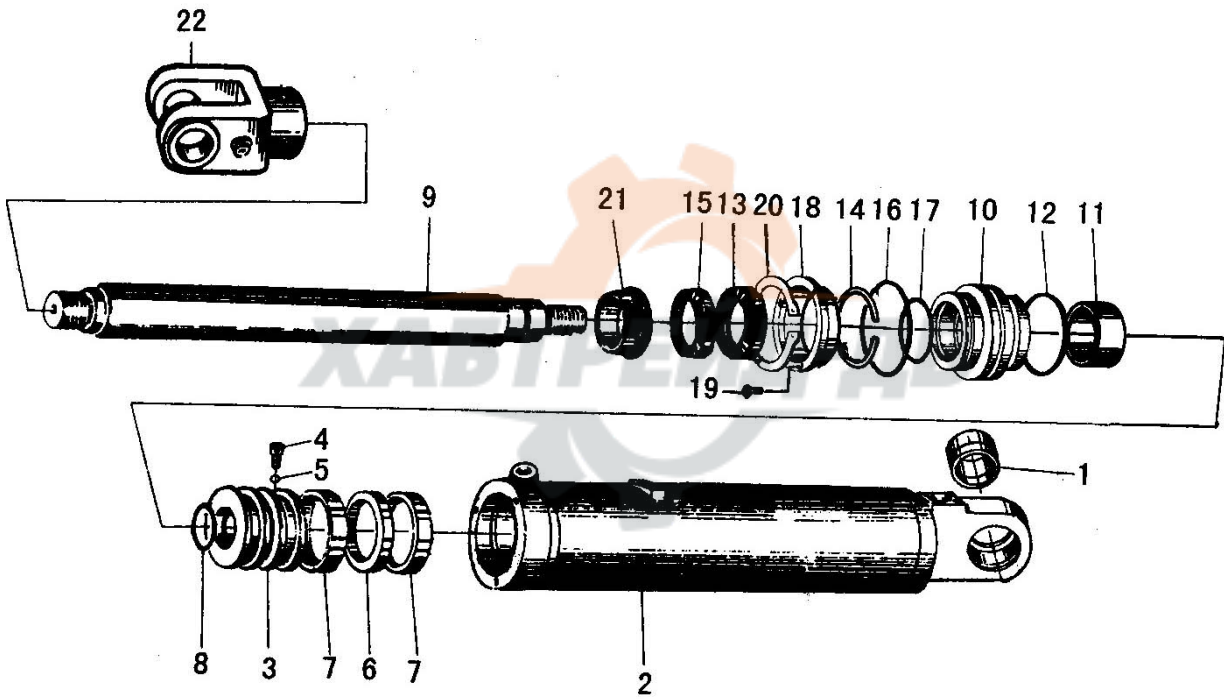

D4

序号	代号	名称		数量	备注
KEY	PART NO.	DESCRIPTION		QTY	REMARKS
1		衬套	BUSH	1	
2		缸体	CYLINDER BODY	1	
3		活塞	PISTON	1	
4		螺钉	SCREW	1	
5		钢球	STEEL BALL	1	
6		孔用组合封	FABRICATE SEALING	1	
7		支撑环	SUPPORTING RING	2	
8		O 形圈	O-RING	1	
9		活塞杆	PISTON ROD	1	
10		导向塞	GUIDE SLEEVE	1	
11		支撑环	SUPPORTING RING	1	
12		O 形圈	O RING	1	
13		轴用组合封	FABRICATE SEALING	1	
14		钢丝挡圈	WIRED CIRCLIP	1	
15		Y 型密封圈	Y DUST RING	1	
16		O 形圈	O RING	1	
17		O 形圈	O RING	1	
18		挡环	SNAP RING	1	
19		螺钉	SCREW	1	
20		弹性挡圈	SNAP RING	3	
21		防尘圈	DUST-PROOF RING	1	
22		耳环座	DOUBLE-EAR RING	1	

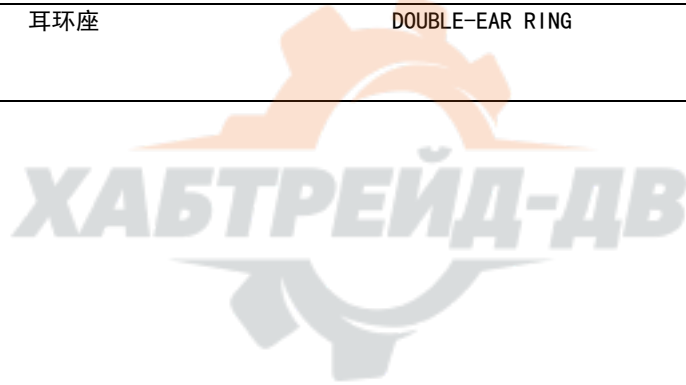

D5

双联泵

TANDEM GEAR PUMP

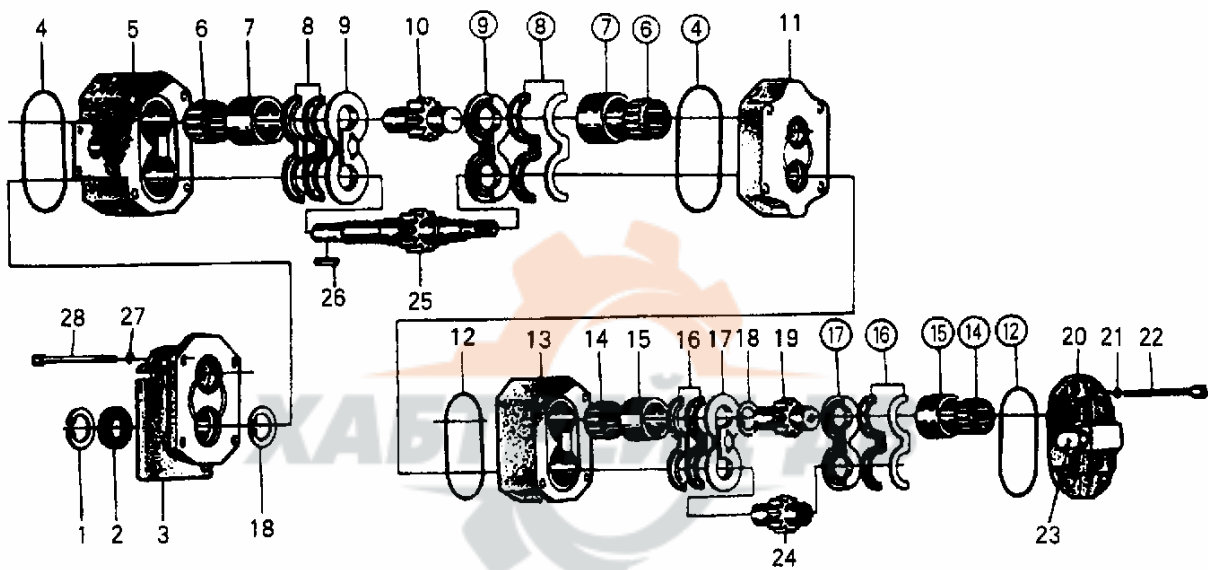

D5

序号	代号	名称	数量	备注
KEY	PART NO.	DESCRIPTION	QTY	REMARKS
1		弹性挡圈	1	
2		油封	2	
3		前盖	1	
4		密封圈	2	
5		前泵体	1	
6		轴承	4	
7		轴套	4	
8		密封件	2	
9		侧板	2	
10		从动齿轮轴	1	
11		中间体	1	
12		矩形密封圈	2	
13		泵体	1	
14		轴承	4	
15		轴套	4	
16		密封件	2	
17		侧板	2	
18		弹性挡圈	1	
19		从动齿轮	1	
20		后盖	1	
21		弹性垫圈	4	
22		螺栓	4	
23		溢流阀	1	
24		主动齿轮	1	
25		主动齿轮轴	1	
26		平键	1	
27		弹性垫圈	4	
28		内六角圆柱螺钉	4	

D6

先导阀总成 PRIORITY VALVE

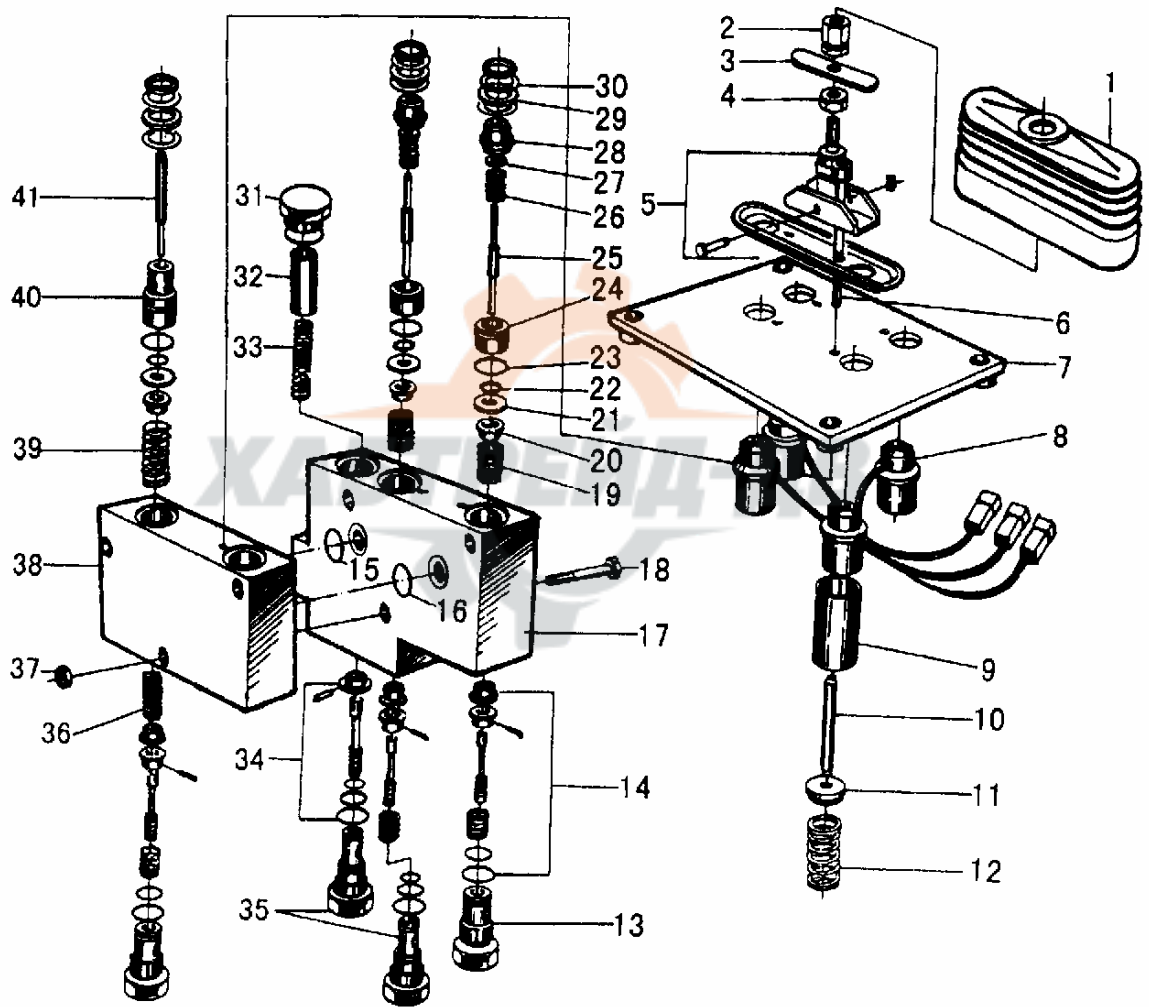

D6

序号	代号	名称	数量	备注
KEY	PART NO.	DESCRIPTION	QTY	REMARKS
1		橡胶罩	RUBBER COVER	2
2		螺纹座	THREAD RETAINER	2
3		压板	PIVOT PLATE	2
4		螺母	NUT	2
5		压销组	CLAMP PIN GROUP	2
6		固定螺栓	SET BOLT	4
7		固定板	SET PLATE	1
8		线圈总成	COIL ASSEMBLY	4
9		弹簧导管	SPRING GUIDE	4
10		挺柱	PLUNGER	4
11		弹簧座	SPRING RETAINER	4
12		回位弹簧	RETURNING SPRING	4
13		阀座	VALVE SEAT	3
14		计量阀芯	METERING VALVE STEM	4
15		密封圈	SEALING RING	1
16		密封圈	SEALING RING	1
17		举升联阀体	VALVE BOLCK , LIFTING PORTION	1
18		螺栓	BOLT	1
19		计量弹簧	METERING SPRING	2
20		垫弹座	RETAINER	8
21		垫片	SPACER	4
22		密封圈	SEALING RING	4
23		密封圈	SEALING RING	4
24		法兰	FLANGE	2
25		压杆	PUSH ROD	2
26		弹簧	SPRING	2
27		垫片	SPACER	2
28		导向座	GUIDE RETAINER	2
29		垫片	SPACER	8
30		绝缘片	ISOLATOR	8
31		螺塞	THREAD PLUG	1
32		弹簧导管	SPRING GUIDE	1
33		弹簧	SPRING	1
34		计量阀芯	METERING VALVE STEM	1
35		阀芯	VALVE SEAT	2
36		弹簧	SPRING	2
37		螺母	NUT	3
38		转斗联阀体	VALVE BOLCK , TILTTING PORTION	1
39		弹簧	SPRING	2
40		导向座	GUIDE RETAINER	2
41		压杆	PUSH ROD	2
42				

E 油箱
TANK



山东临工工程机械有限公司
SHANDONG LINGONG CONSTRUCTION MACHINERY LTD.

E1

燃油箱总成

FUEL TANK ASSEMBLY

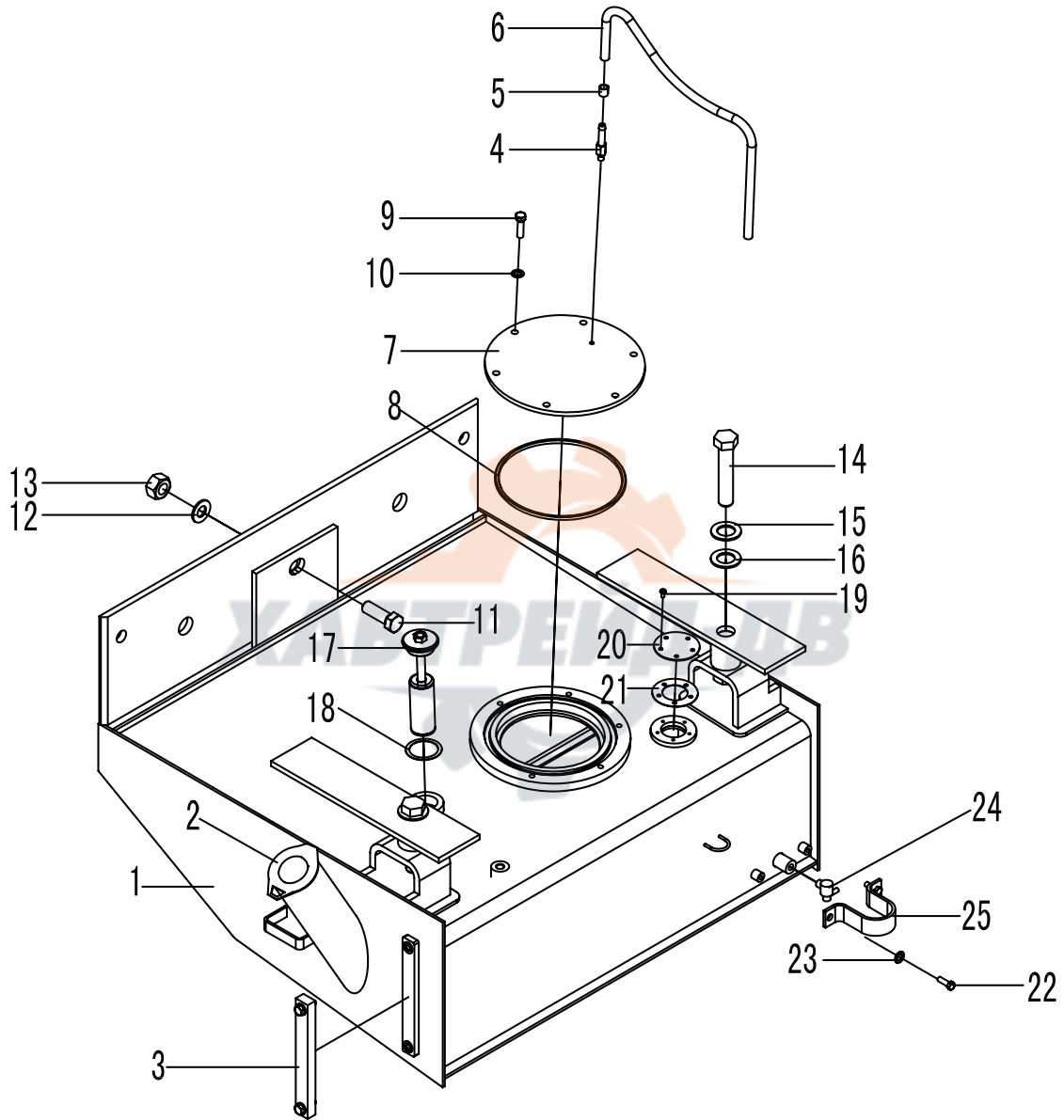

E1

序号	代号	名称		数量	备注
KEY	PART NO.	DESCRIPTION		QTY	REMARKS
1	2902000759	燃油箱体	FUEL TANK	1	
2	4120001404	带锁液压过滤器 SL-50A	LOCK HYDRAULIC FILTER SL-50A	1	
3	4120000093	液位计 YWZ-200	FUEL LEVEL GAUGE YWZ-200	1	
4	2902000656	透气钢管	TUBE	1	
5	4017000015	喉箍 JB8870-d25	CLIP JB8870-d25	1	
6	4120000046	胶管 JB8406-A10*560	TUBE JB8406-A10*560	1	
7	2902000657	盖板	COVER PLATE	1	
8	4030000022	O形圈 GB3452.1-200*7.00G	O-RING GB3452.1-200*7.00G	1	
9	4011000085	螺栓 GB5783-M10*35EpZn-8.8	BOLT GB5783-M10*35EpZn-8.8	6	
10	4015000162	垫圈 GB97.1-10EpZn-300HV	WASHER GB97.1-10EpZn-300HV	6	
11	4011000114	螺栓 GB5785-M20*2*60EpZn-8.8	BOLT GB5785-M20*2*60EpZn-8.8	1	
12	4015000176	垫圈 GB97.1-20EpZn-300HV	WASHER GB97.1-20EpZn-300HV	1	
13	4013000040	螺母 GB6171-M20*2EpZn-8	NUT GB6171-M20*2EpZn-8	1	
14	4011000117	螺栓 GB5785-M24*2*150-8.8	BOLT GB5785-M24*2*150-8.8	2	
15	4015000187	垫圈 GB96.1-24EpZn-300HV	WASHER GB96.1-24EpZn-300HV	2	
16	4015000031	垫圈 GB93-24-65Mn	WASHER GB93-24-65Mn	2	
17	2010900046	滤油器总成	FUEL FILTER	1	
18	3010900068	垫圈	WASHER	1	
19	4014000047	螺钉 GB818-M5*8EpZn-4.8	SCREW GB818-M5*8EpZn-4.8	5	
20	2902000684	法兰盖	FLANGED CAP	1	
21	2902000685	垫片	SPACER	1	
22	4011000106	螺栓 GB5783-M8*25EpZn-8.8	BOLT GB5783-M8*25EpZn-8.8	2	
23	4015000072	垫圈 GB97.1-8EpZn-300HV	WASHER GB97.1-8EpZn-300HV	2	
24	4120000099	球阀 MBS216-1/2"	GLOTTAL VALVE MBS216-1/2"	1	
25	2902000659	护板	GUARD PLATE	1	



E2

液压油箱总成

HYDRAULIC TANK ASSEMBLY

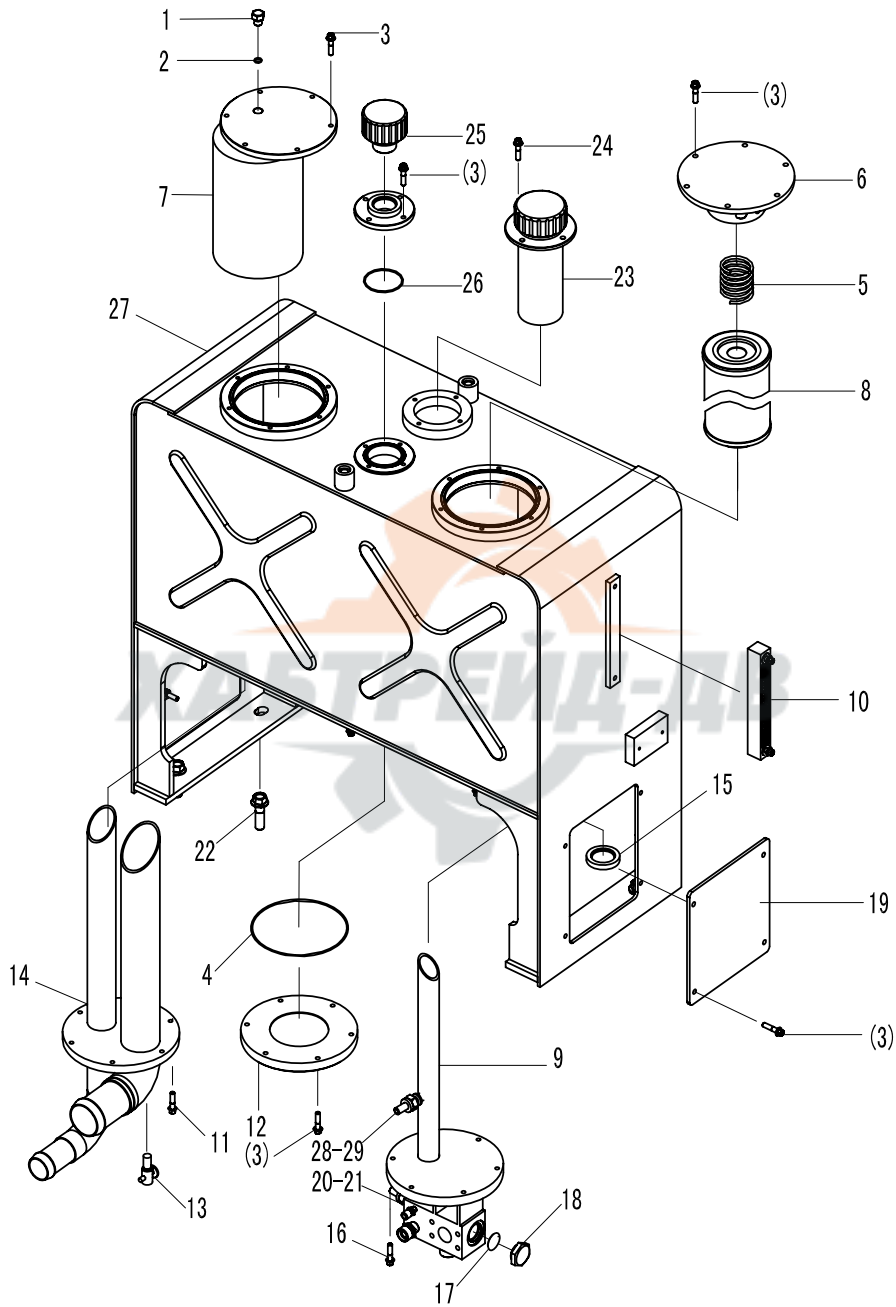

E2

序号	代号	名称		数量	备注
KEY	PART NO.	DESCRIPTION		QTY	REMARKS
1	4041000774	螺塞 LGB153-01422	THREAD PLUG LGB153-01422	1	
2	4041000767	O形圈 LGB168-11124	O-RING LGB168-11124	1	
3	4011000458	螺栓 GB16674-M8*20EpZn-8.8	BOLT GB16674-M8*20EpZn-8.8	24	
4	4030000210	O形圈 GB3452.1-165*3.65G	O-RING GB3452.1-165*3.65G	5	
5	2910000005	弹簧	SPRING	1	65Mn
6	2910000004	回油发兰盖	FLANGE CAP	1	部件
7	2910000407	上部吸油发兰	OIL-SUCTION STRAIN CORE	1	部件
8	2910000406	回油滤芯	STRAIN CORE	1	部件
9	2910000764	回油发兰	OIL-RETURN FLANGE	1	部件
10	4120000093	液位计 YWZ-200	OIL LEVEL YWZ-200	1	部件
11	4011000455	螺栓 GB16674-M8*25EpZn-8.8	BOLT GB16674-M8*25EpZn-8.8	6	
12	2910000036	发兰盖	FRANGE CAP	1	Q235A
13	4120000099	球阀 MBS216-1/2"	BOLL-VALVE MBS216-1/2"	1	部件
14	2910000409	吸油发兰	OIL-SUCTION STRAIN CORE	1	部件
15	4190000008	环形磁铁	ANNULAR MAGNET	1	
16	4011000481	螺栓 GB16674-M8*30EpZn-8.8	BOLT GB16674-M8*30EpZn-8.8	6	
17	4041000192	螺塞 LGB135-03341	THREAD PLUG LGB135-03341	1	
18	4041000765	O形圈 LGB168-12931	O-RING LGB168-12931	1	
19	2910000855	侧板	SIDE BROAD	2	Q235A
20	4041000728	堵塞 LGB14201805	PLUGGING LGB14201805	1	
21	4030000490	O形圈 GB3452.1-10.0*1.80G	O-RING GB3452.1-10.0*1.80G	1	
22	4011000449	螺栓 GB16674-M16*35EpZn-8.8	BOLT GB16674-M16*35EpZn-8.8	4	
23	4120000452	加油滤芯 SFM-323M	OIL-SUPPLYING STRAIN CORE SFM-323M	1	部件
24	4011000461	螺栓 GB16674-M8*16EpZn-8.8	BOLT GB16674-M8*16EpZn-8.8	4	
25	4120001088	换气过滤器 L1.0807-31	GAS-EXCHANGE FILTER L1.0807-31	1	部件
26	4030000233	O形圈 GB3452.1-65*3.55G	O-RING GB3452.1-65*3.55G	1	
27	2910000766	液压油箱体	HYDRAULIC TANK	1	部件
28	4041000598	堵塞 LGB14201604	PLUGGING LGB14201604	1	
29	4030000240	O形圈 GB3452.1-8.00*1.80G	O-RING GB3452.1-8.00*1.80G	1	

F 工作装置
WORKING EQUIPMENT



山东临工工程机械有限公司
SHANDONG LINGONG CONSTRUCTION MACHINERY LTD.

F1

工作装置

WORKING EQUIPMENT

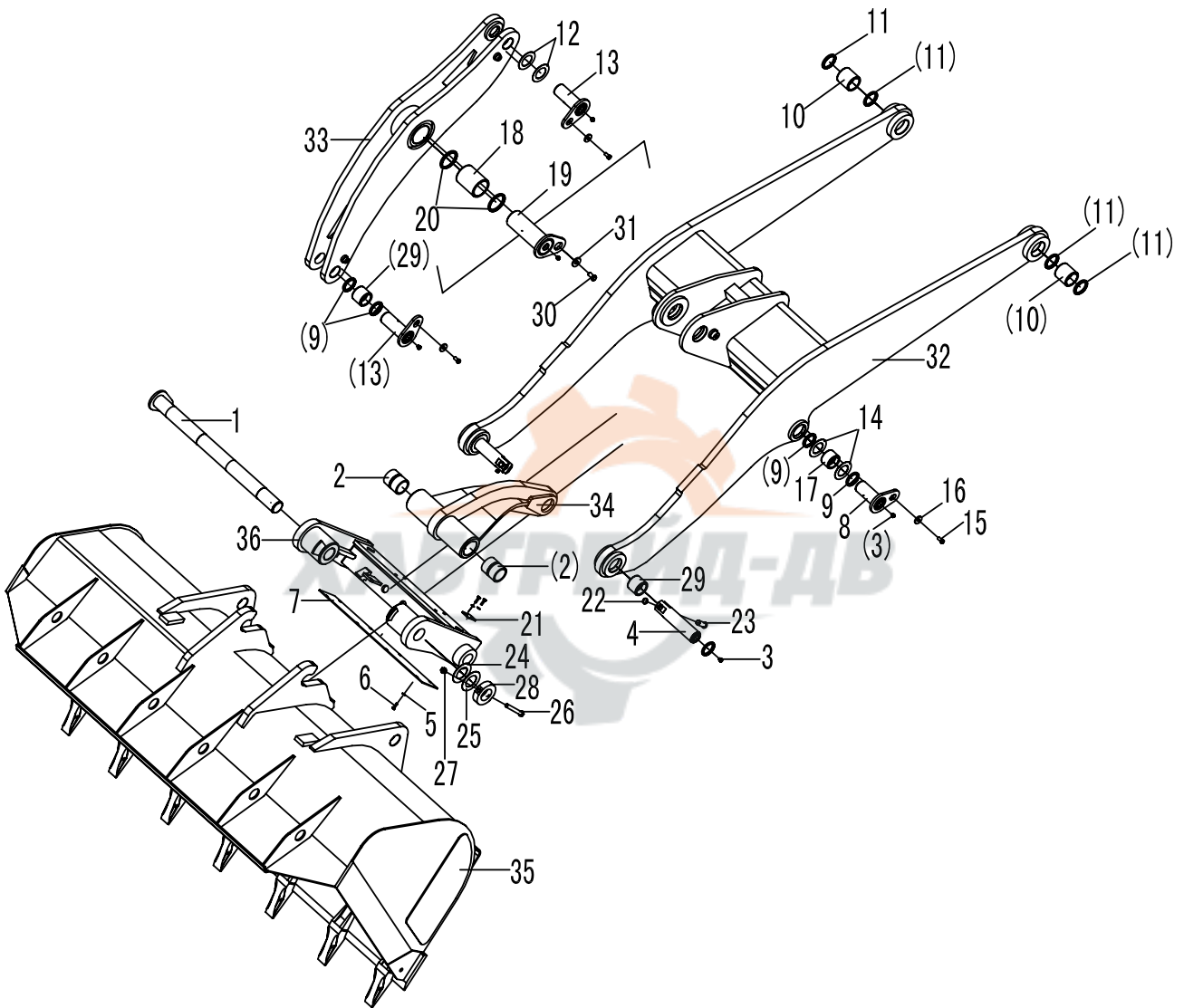

F1

序号	代号	名称		数量	备注
KEY	PART NO.	DESCRIPTION		QTY	REMARKS
1	2916000773	销轴	PIN	1	部件
2	4043000177	轴套 LGB302-65*90B3	BUSH LGB302-65*90B3	2	
3	4030000065	油杯 JB7940.1-M10*1	GREASE NIPPLE JB7940.1-M10*1	9	
4	2916000775	销轴	PIN	2	40Cr
5	4015000072	垫圈 GB97.1-8-300HV	WASHER GB97.1-8-300HV	12	
6	4011000106	螺栓 GB5783-M8*25EpZn-8.8	BOLT GB5783-M8*25EpZn-8.8	12	
7	2916000761	盖板	HOOD	1	Q235A
8	4043000119	销轴 LGB301-60*85*150-40Cr	PIN LGB301-60*85*150-40Cr	2	
9	4043000127	防尘圈 LGB307-60	PUSTRING LGB307-60	10	
10	4043000123	轴套 LGB302-65*80A2	BUSH LGB302-65*80A2	2	
11	4043000128	防尘圈 LGB307-65	PUSTRING LGB307-65	4	
12	4043000126	垫片 LGB303-60*100*2	SPACER LGB303-60*100*2	2	
13	4043000112	销轴 LGB301-60*95*170-40Cr	PIN LGB301-60*95*170-40Cr	2	
14	4043000125	垫片 LGB303-60*100*1	SPACER LGB303-60*100*1	6	
15	4011000197	螺栓 GB5783-M12*25EpZn-8.8	BOLT GB5783-M12*25EpZn-8.8	5	
16	4040000001	垫圈 LGB001-12*45*6	WASHER LGB001-12*45*6	5	
17	4043000121	轴套 LGB302-60*50A2	BUSH LGB302-60*50A2	2	
18	4043000124	轴套 LGB302-85*125A2	BUSH LGB302-85*125A2	1	
19	4043000120	销轴 LGB301-85*132*245-40Cr	PIN LGB301-85*132*245-40Cr	1	
20	4043000056	防尘圈 LGB307-85	PUSTRING LGB307-85	2	
21	2916000769	压板	PRESS PLATE	2	Q235A
22	4015000166	挡圈 GB894.1-22	SHIELD RING GB894.1-22	2	
23	2916000763	锁销	LOCKPIN	2	40Cr
24	4043000068	垫片 LGB303-65*110*1	SPACER LGB303-65*110*1	1	
25	4043000176	垫片 LGB303-65*110*2	SPACR LGB303-65*110*2	1	
26	4011000211	螺栓 GB5782-M16*140EpZn-8.8	BOLT GB5782-M16*140EpZn-8.8	1	
27	4013000016	螺母 GB6170-M16EpZn-8	NUT GB6170-M16EpZn-8	2	
28	2916000774	盘	DISC	1	Q345A
29	4043000122	轴套 LGB302-60*60A2	BUSH LGB302-60*60A2	3	
30	4011000094	螺栓 GB5783-M16*30EpZn-8.8	BOLT GB5783-M16*30EpZn-8.8	1	
31	4040000002	垫圈 LGB001-16*50*6	WASHER LGB001-16*50*6	1	
32	2915000817	动臂	LIFT ARM	1	
33	2915000861	摇臂	ROCHER ARM	1	
34	2915000783	连杆	LINKAGE ROD	1	
35	2917001322	铲斗	BUCKET	1	
36	2918000783	快换装置	QUICK-CHANGE DEVICE	1	

G 转向系统

STEERING SYSTEM



山东临工工程机械有限公司
SHANDONG LINGONG CONSTRUCTION MACHINERY LTD.

G1

序号	代号	名称		数量	备注
KEY	PART NO.	DESCRIPTION		QTY	REMARKS
1	4041000516	软管 LGB164-010150	PIPE LGB164-010150	1	
2	2920000402	转向器出油钢管 A	OIL OUTLET TUBE OF STEERING GEAR (A)	1	部件
3	4030000501	O 形圈 GB3452.1-15.0*1.80G	O-RING GB3452.1-15.0*1.80G	2	
4	2920000403	转向器出油钢管 B	OIL OUTLET TUBE OF STEERING GEAR (B)	1	部件
5	4120000360	方向盘 FXP-950	STEERING WHEEL FXP-950	1	
6	4120000019	转向柱 FZ2-770-HEaF	STEERING POLE FZ2-770-HEaF	1	
7	4041000564	直接头 LGB120-02620	JOINT LGB120-02620	4	
8	4041000783	O 形圈 LGB168-11724	O-RING LGB168-11724	4	
9	4011000475	螺栓 GB16674-M10*30EpZn-8.8	BOLT GB16674-M10*30EpZn-8.8	4	
10	4120001317	转向器 BZZ5-500	STEERING GEAR BZZ5-500	1	
11	2920000778	优先阀反馈油管	FEEDBACK PIPE OF PRIORITY VALVE	1	部件
12	4041000131	直接头 LGB120-01412	JOINT LGB120-01412	3	
13	4041000784	O 形圈 LGB168-10924	O-RING LGB168-10924	3	
14	4041000794	软管 LGB128-010037	PIPE LGB128-010037	1	
15	4041000187	直接头 LGB120-02622	JOINT LGB120-02622	1	
16	4041000771	O 形圈 LGB168-11924	O-RING LGB168-11924	1	
17	4011000302	螺栓 GB16674-M8*75EpZn-8.8	BOLT GB16674-M8*75EpZn-8.8	2	
18	4120000709	优先阀 VLE-150	PRIORITY VALVE VLE-150	1	
19	4041000188	直接头 LGB120-03028	JOINT LGB120-03028	1	
20	4041000779	O 形圈 LGB168-12331	O-RING LGB168-12331	1	
21	4041000514	软管 LGB165-003121	PIPE LGB165-003121	1	
22	2919000782	转向泵出油钢管	OIL OUTLET TUBE OF STEERING PUMP	1	部件
23	4011000475	螺栓 GB16674-M10*30EpZn-8.8	BOLT GB16674-M10*30EpZn-8.8	12	
24	4041000026	分体法兰 LGB117-310491	FLANGE LGB117-310491	2	
25	4030000026	O 形圈 GB3452.1-32.5*3.55G	O-RING GB3452.1-32.5*3.55G	2	
26	2919000783	转向泵至优先阀胶管	PIPE OF PRIORITY VALVE	1	部件
27	2919000414	优先阀进油钢管	INLET TUBE OF PRIORITY VALVE	1	部件
28	4030000241	O 形圈 GB3452.1-20.0*1.80G	O-RING GB3452.1-20.0*1.80G	1	
29	4041000774	螺塞 LGB135-01421	PLUG SCREW LGB135-01421	1	
30	4041000767	O 形圈 LGB168-11124	O-RING LGB168-11124	1	
31	4030000028	O 形圈 GB3452.1-36.5*3.55G	O-RING GB3452.1-36.5*3.55G	1	
32	4041000056	分体法兰 LGB117-312550	FLANGE LGB117-312550	1	
33	2919000784	转向泵吸油钢管	INLET TUBE OF STEERING PUMP	1	部件
34	4120001060	转向泵 CBGj2063	STEERING PUMP CBGj2063	1	
35	2919000781	密封垫	SEALING PLATE	1	耐油石棉橡胶板
36	4012000025	螺柱 GB898-M16*40EpZn-8.8	DOUBLE-SCREW BOLT GB898-M16*40EpZn-8.8	4	
37	4015000181	垫圈 GB97.1-16EpZn-300HV	WASHER GB97.1-16EpZn-300HV	4	
38	4013000016	螺母 GB6170-M16EpZn-8	NUT GB6170-M16EpZn-8	4	
39	4030000425	吸油胶管 HG4-763-45*670	INLET PIPE HG4-763-45*670	1	
40	4017000007	JB8870-d60	JB8870-d60	4	
41	2921000408	钢管	TUBE	1	部件
42	4030000275	O 形圈 GB3452.1-22.4*3.55G	O-RING GB3452.1-22.4*3.55G	2	
43	4011000481	螺栓 GB16674-M8*30EpZn-8.8	BOLT GB16674-M8*30EpZn-8.8	4	
44	4011000277	螺栓 GB16674-M8*40EpZn-8.8	BOLT GB16674-M8*40EpZn-8.8	4	
45	2921000409	钢管	TUBE	1	部件
46	4041000563	软管 LGB128-006078	PIPE LGB128-006078	2	
47	4120001004	转向油缸 HSGL-80*45*327-594	STEERING CYLINDER HSGL-80*45*327-594	2	
48	2921000766	转向缸进油胶管	OIL INLET PIPE OF STEERING CYLINDER	2	部件
49	2921000406	固定座	PERMANENT SEAT	1	部件
50	2921000407	橡胶板	RUBBER PLATE	2	耐油橡胶
51	4011000476	螺栓 GB16674-M10*70EpZn-8.8	BOLT GB16674-M10*70EpZn-8.8	1	

G2

转向器总成 STEERING GEAR

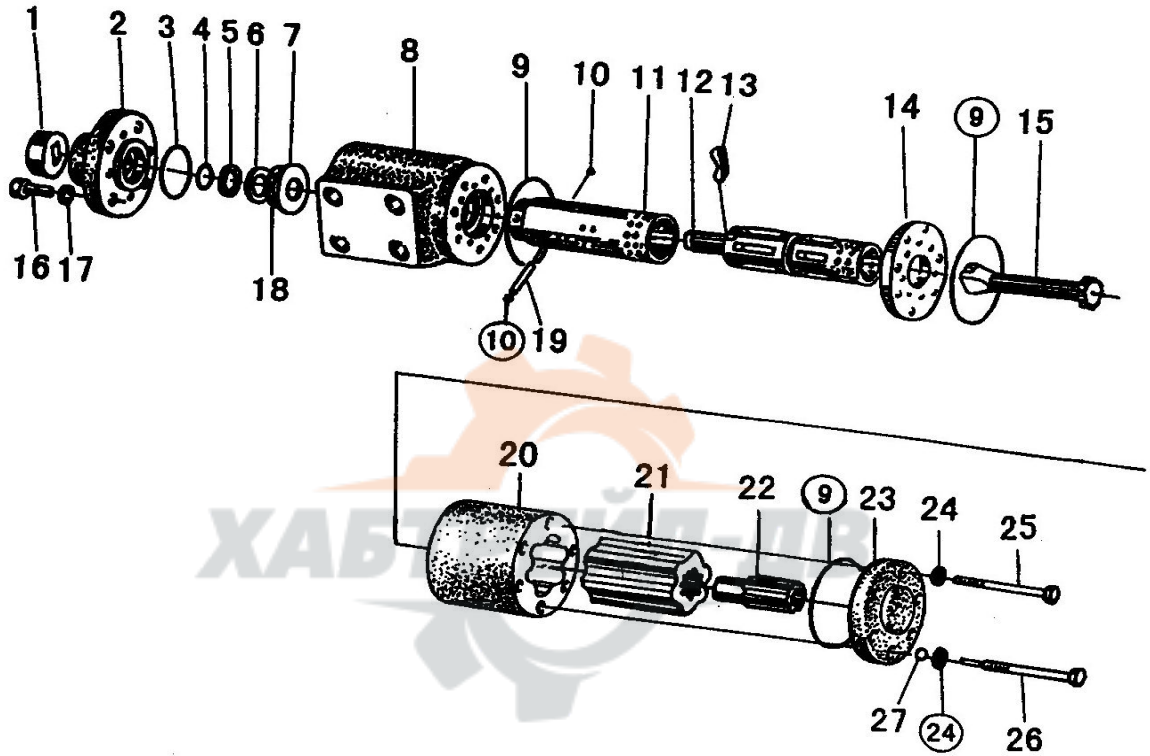

G2

序号	代号	名称		数量	备注
KEY	PART NO.	DESCRIPTION		QTY	REMARKS
1		转向器	CONNECTING BLOCKS MODULE	1	
2		前盖	FRONT COVER	1	
3		O形圈	O-RING	1	
4		O形圈	O-RING	1	
5		X形圈	X-RING	1	
6		垫	GASKET	1	
7		挡环	GASKET	1	
8		阀体	VALVE BLOCK	1	
9		O形圈	O-RING	3	
10		垫片	GASKET	2	
11		阀套	VALVE SLEEVE	1	
12		阀芯	VALVE STEM	1	
13		弹簧片	SPRING SLIP	6	
14		隔盘	ISOLATING PLATE	1	
15		联动轴	COUPLING SHAFT	1	
16		螺钉	SCREW	4	
17		垫圈	WASHER	4	
18		推力滚针轴承	THRUST NEEDLE BEARING	1	
19		拔销	CENTER PIN	1	
20		定子	STATOR MODULE	1	
21		转子	ROTOR	1	
22		限位柱	STOPPER	1	
23		后盖	REAR COVER	1	
24		组合密封垫	SEAL RING	7	
25		螺栓	BOLT	6	
26		限位螺栓组件	CAGING BOLT MODULE	1	
27		钢球	STEEL BALL	1	

优先阀总成 PRIORITY VALVE

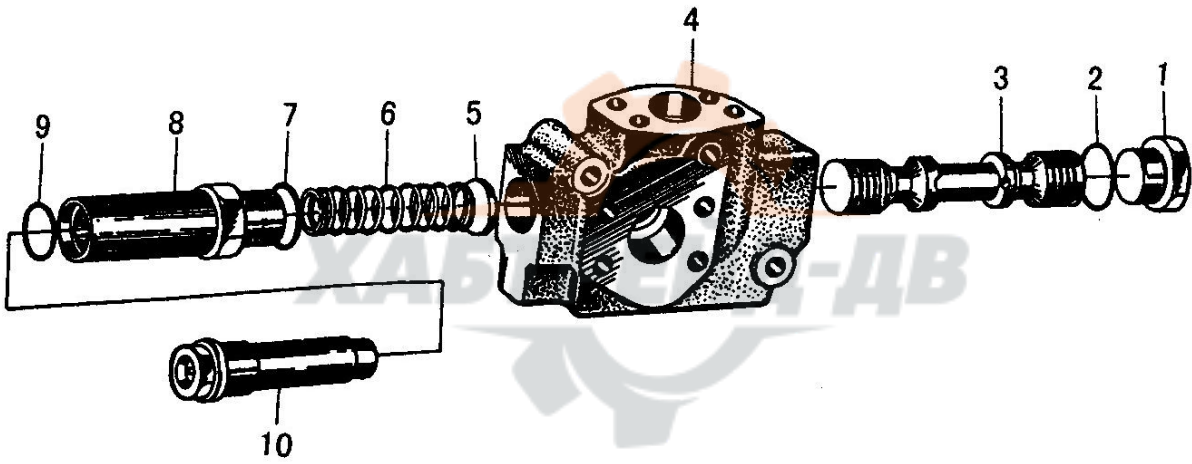

G3

序号	代号	名称		数量	备注
KEY	PART NO.	DESCRIPTION		QTY	REMARKS
1		丝堵	THREAD PLUG	1	
2		O 形圈	O-RING	1	
3		阀芯	VALVE SPOOL	1	
4		阀体	VALVE BODY	1	
5		弹簧座	RETAINER	1	
6		主阀弹簧	SPRING	1	
7		O 形圈	O-RING	1	
8		安全阀阀座	SAFETY VALVE SEAT	1	
9		O 形圈	O-RING	1	
10		安全阀总成	SAFETY VALVE ASY	1	



转向油缸总成 STEERING CYLINDER

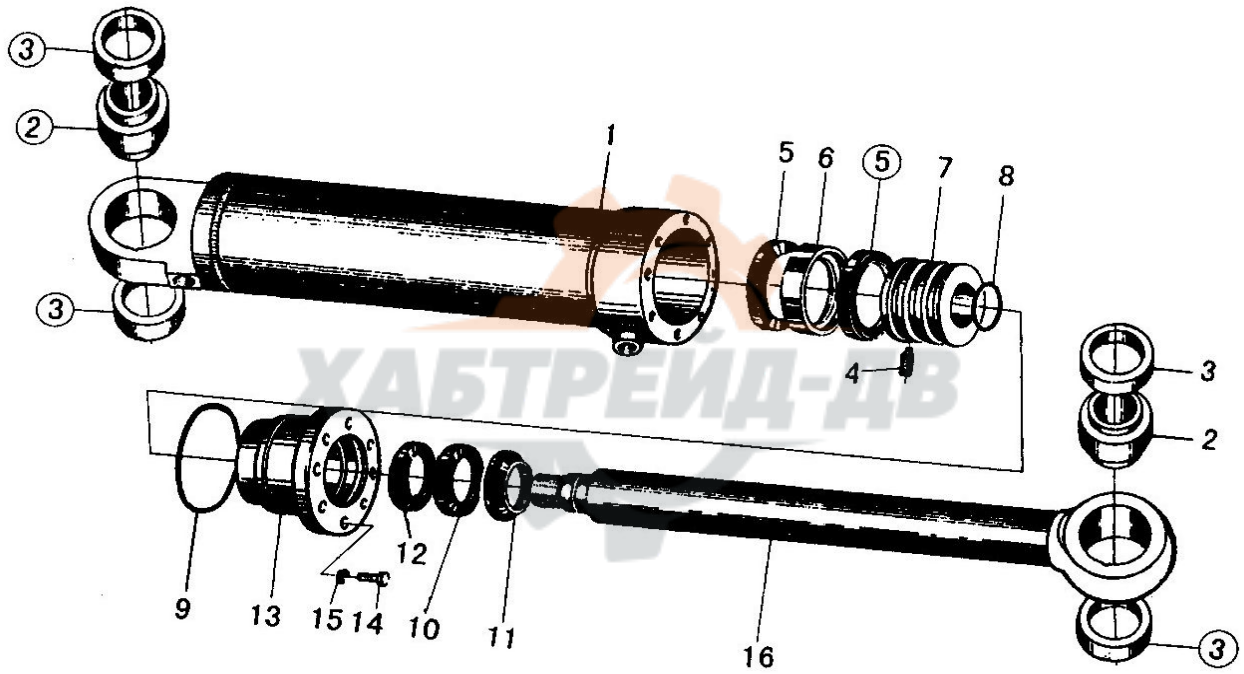

G4

序号	代号	名称		数量	备注
KEY	PART NO.	DESCRIPTION		QTY	REMARKS
1		缸体	CYLINDER BODY	1	
2		关节轴承	SPHERICAL PLAIN BEARING	2	
3		挡环	SPCER RING	4	
4		紧定螺钉	SCREW		
5		支撑环	SUPPORTING RING		
6		孔用组合封	FABRICATE SEALING		
7		活塞	PISTON	1	
8		O形圈	O-RING	1	
9		O形圈	O-RING	1	
10		密封圈	SEALRING-RING	1	
11		防尘圈	PUST PROOD RING	1	
12		轴用组合封	TABRICATE SEALING	1	
13		缸盖	CYLINDER	1	
14		螺栓	BOLT	8	
15		垫圈	WASHER	8	
16		活塞杆	PISTON	1	



H 制动系统 BRAKE SYSTEM



山东临工工程机械有限公司
SHANDONG LINGONG CONSTRUCTION MACHINERY LTD.

H1

序号	代号	名称		数量	备注
KEY	PART NO.	DESCRIPTION		QTY	REMARKS
1	2922000405	三通接头	TEE OF THE OIL LINE	1	35
2	4011000455	螺栓 GB16674-M8*25EpZn-8.8	BOLT GB16674-M8*25EpZn-8.8	8	
3	2922000406	前桥制动油管	TUBE OF FRONT AXLE	2	部件
4	4041000704	软管 LGB153002050	TUBE LGB153002050	1	
5	4120001328	气制动阀 LG22-ZDF	BRAKE VALVE LG22-ZDF	1	部件
6	2901000004	螺栓	BOLT	4	35
7	2901000006	垫圈	WASHER	11	软钢纸板
8	2922000403	储气罐至脚制动阀气管	TUBE FROM AIR RESERVOIR TO BRAKE VALVE	1	部件
9	2922000118	脚制动阀至后加力泵气管	TUBE FROM BRAKE VALVE TO REAR BOOSTER	1	部件
10	2922000053	储气罐	AIR RESERVOIR	1	部件
11	4011000560	螺栓 GB16674-M12*25EpZn-8.8	BOLT GB16674-M12*25EpZn-8.8	4	
12	2922000407	后桥左油管	TUBE OF REAR AXLE (LEFT)	1	部件
13	2922000013	三通接头	TEE OF THE OIL LINE	1	35
14	2922000002	垫圈	WASHER	10	T2
15	2922000003	制动器管接头	CONNECTOR	2	35
16	2922000016	加力泵管接头	CONNECTOR	2	35
17	2922000017	垫圈	WASHER	2	T2
18	4120000090	加力泵 XZ-60	BOOSTER XZ-60	2	部件
19	4041000552	软管 LGB152002180	TUBE LGB152002180	1	
20	2922000408	后桥右油管	TUBE OF REAR AXLE (RIGHT)	1	部件
21	4041000724	软管 LGB151004215	TUBE LGB151004205	1	
22	2901000005	垫圈	WASHER	4	软钢纸板
23	2901000007	二通接头	CONNECTOR	4	35
24	4011000447	螺栓 GB16674-M10*20EpZn-8.8	BOLT GB16674-M10*20EpZn-8.8	4	
25	2922000409	管接头	CONNECTOR	2	35
26	4120000750	金属软管	METAL TUBE	1	部件
27	2922000402	油水分离器支架	BRACKET FOR AIR DYER	1	Q235A
28	4120000084	油水分离器组合阀 ST-50G	AIR DYER ST-50G	1	部件
29	4041000560	软管 LGB149004220	TUBE LGB149004220	1	部件
30	3090900004	制动盘	BRAKE DISC	4	
31	4110000012	ZL40 盘式制动器 LG09-ZDQ	ZL40 DISC BRAKE LG09-ZDQ	4	

H2

盘式制动器 DISK BRAKE

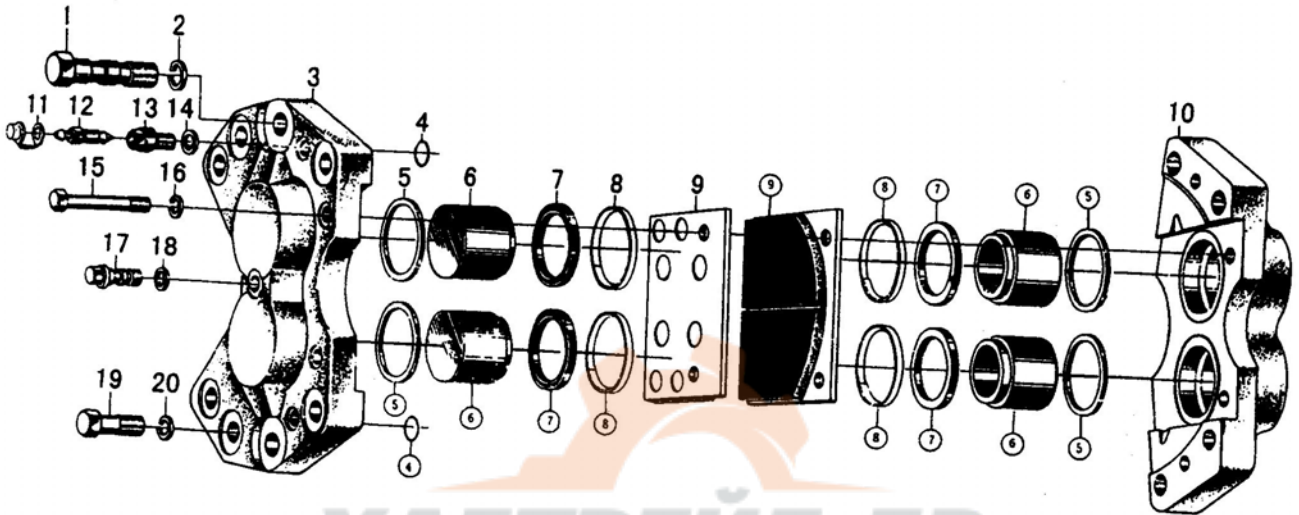

H2

序号	代号	名称		数量	备注
KEY	PART NO.	DESCRIPTION		QTY	REMARKS
1		螺栓	BOLT	4	
2		垫圈 22	WASHER 22	4	
3		内钳	INTERNAL PLIERS	1	
4		O 形圈 20*2.4	O-RING 20*2.4	2	
5		矩形密封圈	SQUQRE SEAL	4	
6		活塞	PISTON	4	
7		防尘罩	DUST	4	
8		卡圈	RETAINER RING	4	
9		制动片	BRAKE SHOE	4	
10		外钳	EXTERNAL PLIERS	1	
11		橡皮帽	RUBBER COVER	2	
12		放气嘴	AIR BLEEDER	2	
13		接头	CONNECTOR	2	
14		O 形圈 16*2.4	O-RING 16*2.4	2	
15		螺栓销	BOLT PIN	2	
16		垫圈 10	WASHER 10	2	
17		管接头	TUBE CONNECTOR	1	
18		垫圈	WASHER	1	
19		螺栓	BOLT	4	
20		垫圈 20	WASHER 20	4	



H3

储气罐、制动阀、油水分离器

AIR RESERVOIR, BRAKE CONTROL VALVE, AIR DRYER

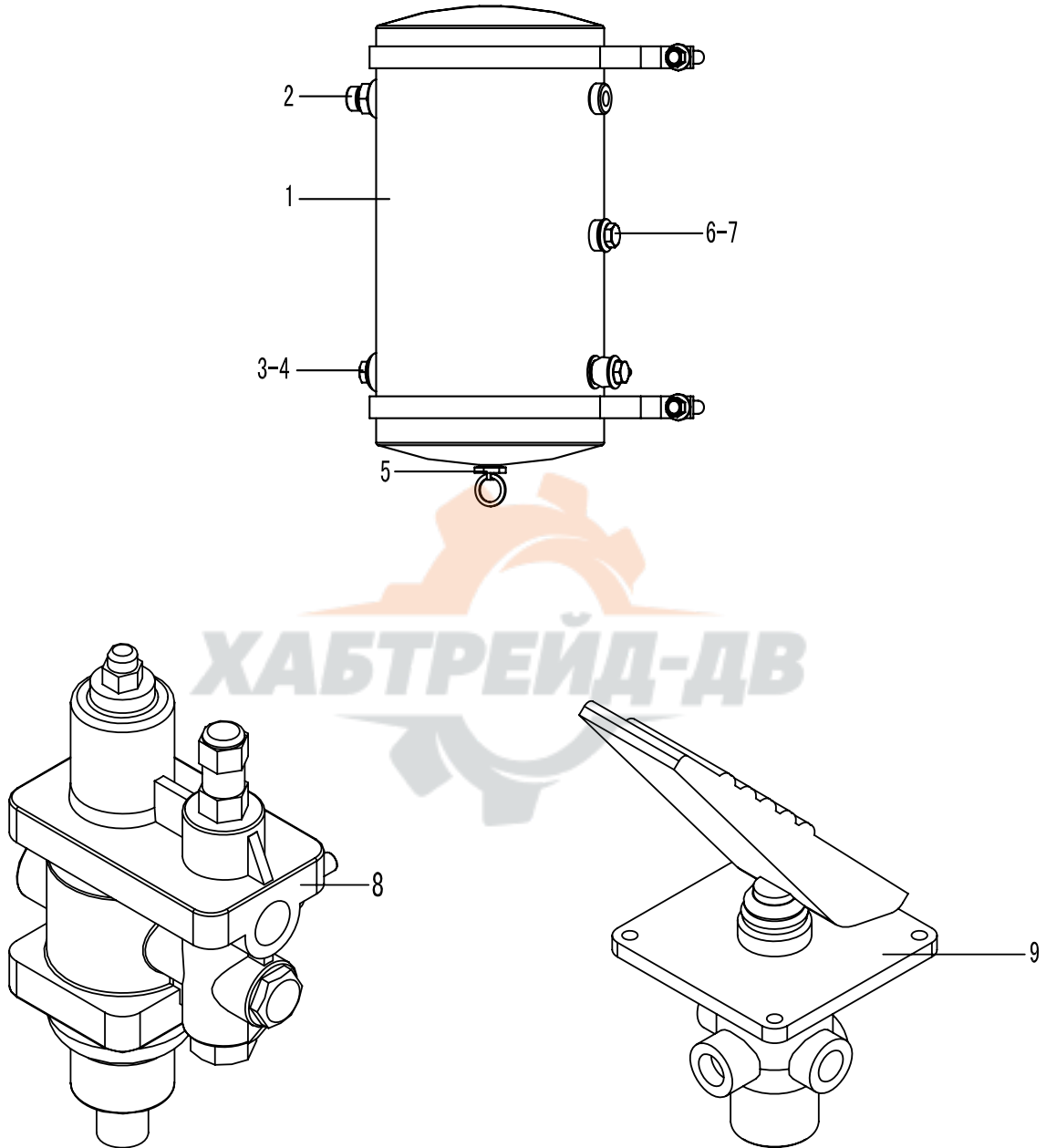

H3

序号	代号	名称		数量	备注
KEY	PART NO.	DESCRIPTION		QTY	REMARKS
1	2922000054	罐体	AIR RESERVOIR	1	部件
2	4120000065	安全阀	SAFETY VALVE	1	部件
3	4120000742	轮胎充气阀	CHARGE VALVE FOR TIRE	1	部件
4	2901000006	垫圈	WASHER	2	软钢纸板
5	4120000066	791 手动放水阀	791-WATER DRAIN VALVE	1	部件
6	4030000311	螺塞 JB1000-M10*1-35	PLUG JB1000-M10*1-35	1	
7	2923000014	垫圈	WASHER	1	软钢纸板
8	4120000084	油水分离器组合阀 ST-50G	COMBINED VALVE FOR WATER SEPARATOR	1	
9	4120000089	脚制动阀 XM-60	BRAKE CONTROL VALVE XM-60	1	



H4

加力泵总成 BRAKE BOOSTER

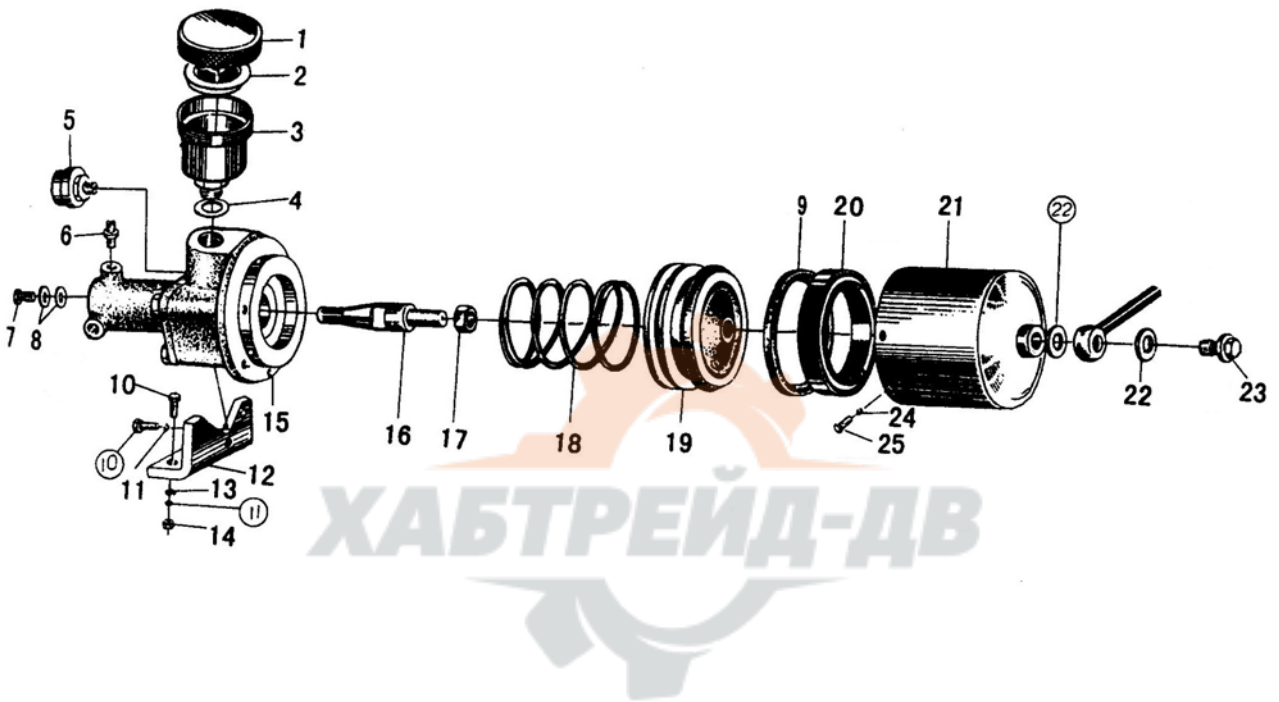

H4

序号	代号	名称		数量	备注
KEY	PART NO.	DESCRIPTION		QTY	REMARKS
1		油杯盖	OIL RESERVOIR COVER	2	
2		过滤套	FILTER SLEEVE	2	
3		油杯体	OIL RESERVOIR	2	
4		O形圈 40*3.1	O-RING 40*3.1	2	
5		放气嘴	AIR BLEEDER	2	
6		接头	CONNECTOR	2	
7		管接头	FITTING	2	
8		垫圈	WASHER	4	
9		密封圈	SEALING WASHER	2	
10		螺栓 M10*20-Ep·Zn	BOLT M10*20-Ep·Zn	8	
11		垫圈 10	LOCK WASHER 10	8	
12		支架	BRACKET	2	
13		垫圈 10	WASHER 10	8	
14		螺母 M10	NUT M10	4	
15		制动总泵	BRAKE MAIN PUMP	2	
16		推杆	PUSH ROD	2	
17		螺母 M12*1.5	NUT M12*1.5	2	
18		弹簧	SPRING	2	
19		活塞	PISTON	2	
20		YX形密封圈	YX-RING SEAL	2	
21		加力缸	BOOSTING TANK	2	
22		垫圈	WASHER	4	
23		螺栓	BOLT	2	
24		垫圈 8	WASHER 8	12	
25		螺栓 M8*16	BOLT M8*16	12	



H5

驻车制动系统

PARKING BRAKE SYSTEM

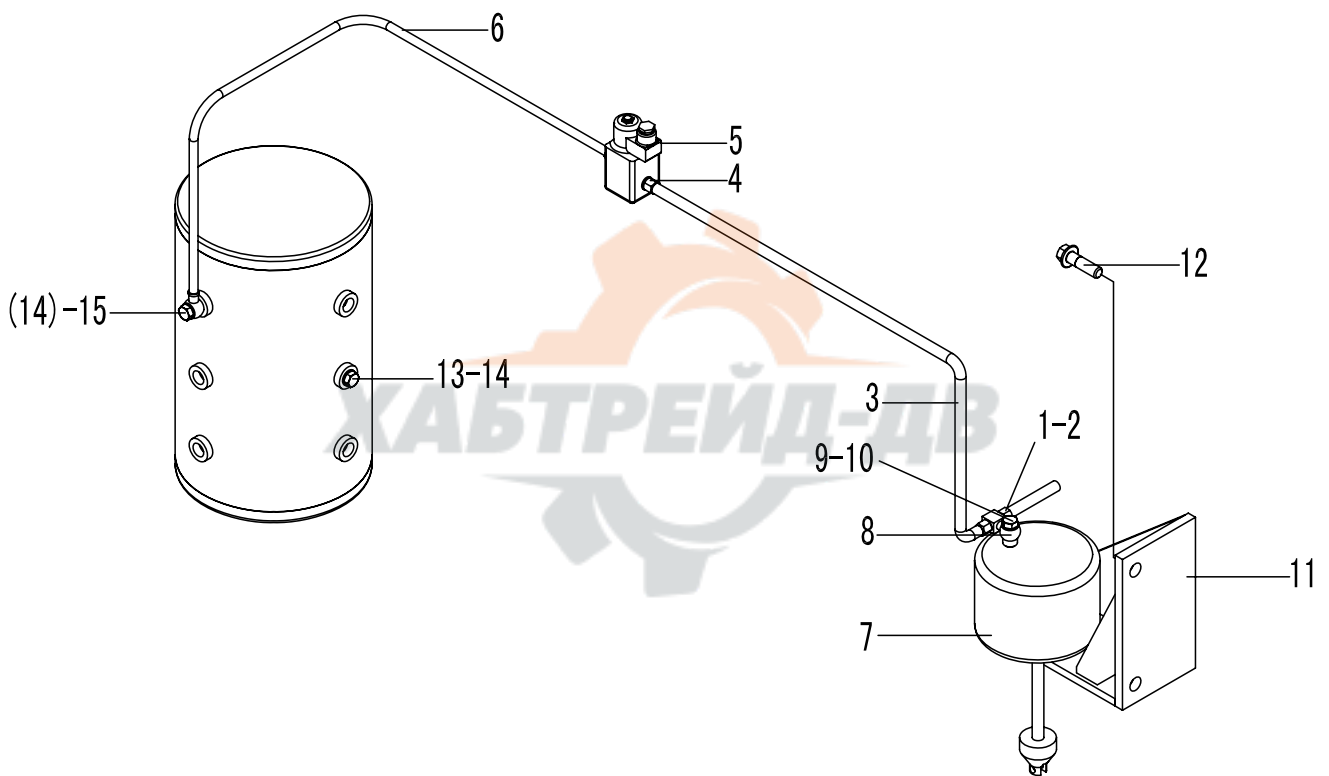

H5

序号	代号	名称		数量	备注
KEY	PART NO.	DESCRIPTION		QTY	REMARKS
1	4130000055	气压信号灯开关 HFF-3757002	SWITCH HFF-3757002	1	
2	2901000005	垫圈	WASHER	1	软钢纸板
3	2923000773	电磁阀出气管	PIPE	1	部件
4	2923000012	接头体	CONNECTOR	2	35
5	4120000759	制动电磁阀 LG23-DCF	BRAKE VALVE LG23-DCF	1	
6	2923000013	电磁阀进气管	PIPE	1	部件
7	4120000506	驻车制动气室	AIR RESERVOIR	1	部件
8	2923000015	三通块	THREE-WAY PIPE	1	部件
9	4011000339	螺栓 JB999-M14*1.5*28-35	BOLT JB999-M14*1.5*28-35	1	
10	2923000003	垫圈	WASHER	2	软钢纸板
11	2923000767	支架	BRACKET	1	部件
12	4011000480	螺栓 GB16674-M20*40EpZn-8.8	BOLT GB16674-M20*40EpZn-8.8	2	
13	4120000760	压力开关 LY-3720002	SWITCH LY-3720002	1	
14	2923000014	垫圈	WASHER	3	软钢纸板
15	4011000283	螺栓 JB999-M10*1*18-35	BOLT JB999-M10*1*18-35	1	



I 车架 FRAME



山东临工工程机械有限公司
SHANDONG LINGONG CONSTRUCTION MACHINERY LTD.

前车架总成 FRONT FRAME

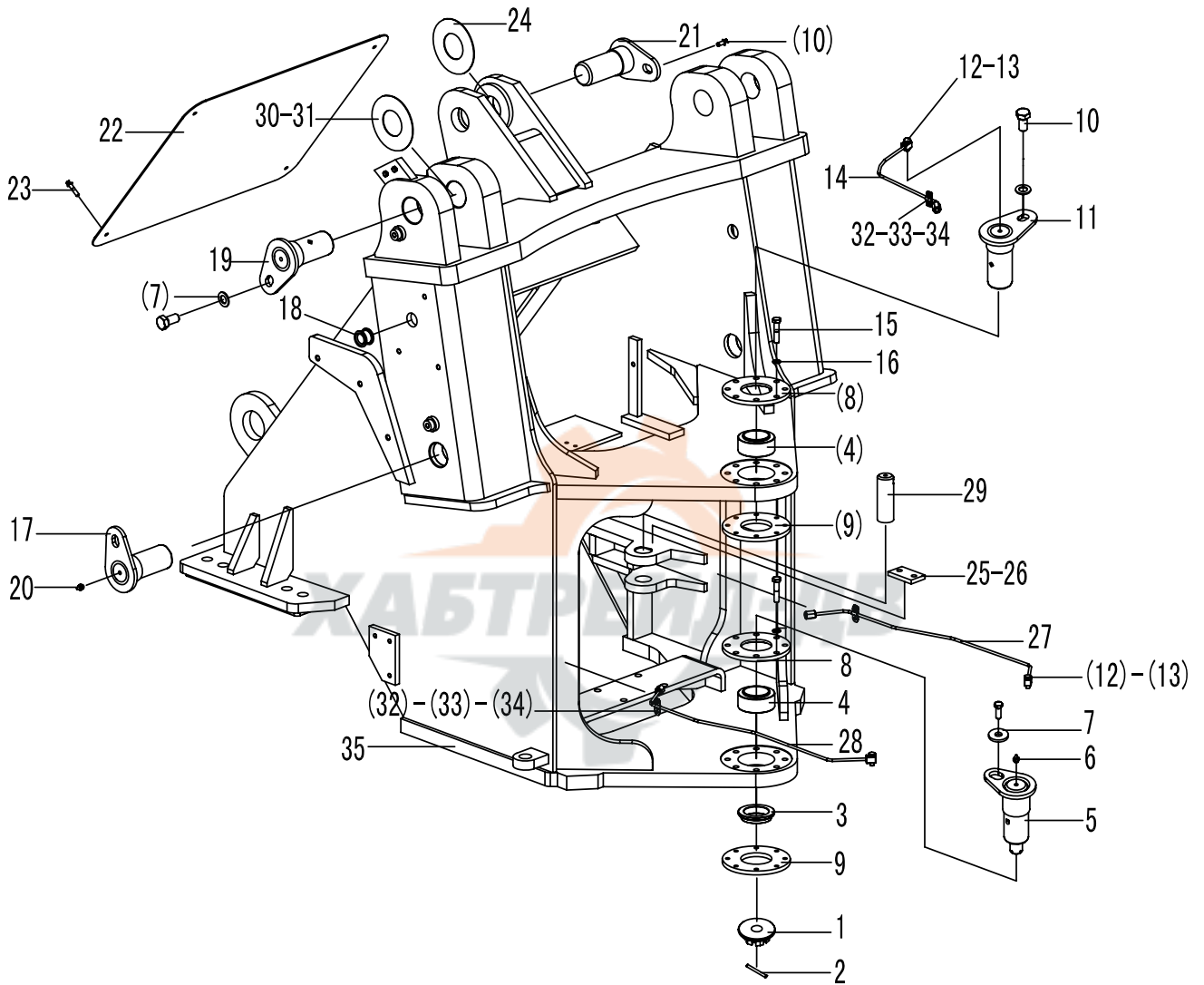

序号	代号	名称		数量	备注
KEY	PART NO.	DESCRIPTION		QTY	REMARKS
1	2925000106	开槽螺母	SLOTTED NUT	1	
2	4016000113	开口销 GB91-6. 3*63EpZn-Q235A	SPLIT PIN GB91-6. 3*63EpZn-Q235A	1	
3	2925000759	套	BUSH	1	
4	4021000042	关节轴承 GB9163-GE60ES-2RS	BEARING GB9163-GE60ES-2RS	2	
5	2925000403	下铰接销	DOWN ARTICULATION PIN	1	
6	4030000199	油杯 JB7940. 2-90° M10*1	GREASE NIPPLE JB7940. 2-90° M10*1	1	
7	4040000001	垫圈 LGB001-12	WASHER LGB001-12	7	
8	2925000401	盘	DISC	2	
9	2925000402	盘	DISC	2	
10	4011000197	螺栓 GB5783-M12*25EpZn-8. 8	BOLT GB5783-M12*25EpZn-8. 8	11	
11	2925000404	上铰接销	UP ARTICULATION PIN	1	
12	2925000029	通油螺栓	OIL BOLT	3	
13	2925000030	垫片	SPACER	6	
14	2925000409	油管	OIL TUBE	1	
15	4011000186	螺栓 GB5782-M12*55EpZn-8. 8	BOLT GB5782-M12*55EpZn-8. 8	16	
16	4015000026	垫圈 GB93-12-65Mn	WASHER GB93-12-65Mn	20	
17	4043000205	销轴 LGB301-60*125*235G-40Cr	PIN LGB301-60*125*235G-40Cr	2	
18	2925000135	走线胶套	RUBBER SLEEVE	4	
19	4043000204	销轴 LGB301-65*122*235G-40Cr	PIN LGB301-65*122*235G-40Cr	2	
20	4030000065	油杯 JB7940. 1-M10*1	GREASE NIPPLE JB7940. 1-M10*1	8	
21	4043000203	销轴 LGB301-60*95*170G-40Cr	PIN LGB301-60*95*170G-40Cr	1	
22	2925000417	前盖板	FRONT HOOD	1	
23	4011000461	螺栓 GB16674-M8*16EpZn-8. 8	BOLT GB16674-M8*16EpZn-8. 8	4	
24	4043000151	垫片 LGB303-60*120*1	SPACER LGB303-60*120*1	4	
25	2925000111	卡板	PLATE	2	
26	2925000112	卡板	PLATE	2	
27	2925000406	右注油管	OIL TUBE (RIGHT)	1	
28	2925000407	左注油管	OIL TUBE (LEFT)	1	
29	2925000408	前转向销	FRONT PIN OF STEERING CYLINDER	2	
30	4043000197	垫片 LGB303-65*140*1	SPACER LGB303-65*140*1	2	
31	4043000198	垫片 LGB303-65*140*2	SPACER LGB303-65*140*2	2	
32	4014000024	螺钉 GB818-M6*10EpZn-4. 8	SCREW GB818-M6*10EpZn-4. 8	6	
33	4015000035	垫圈 GB93-6-65Mn	WASHER GB93-6-65Mn	6	
34	2925000031	管夹	PIPE CLIP	3	
35	2924000856	前车架	FRONT FRAME	1	

后车架总成 REAR FRAME

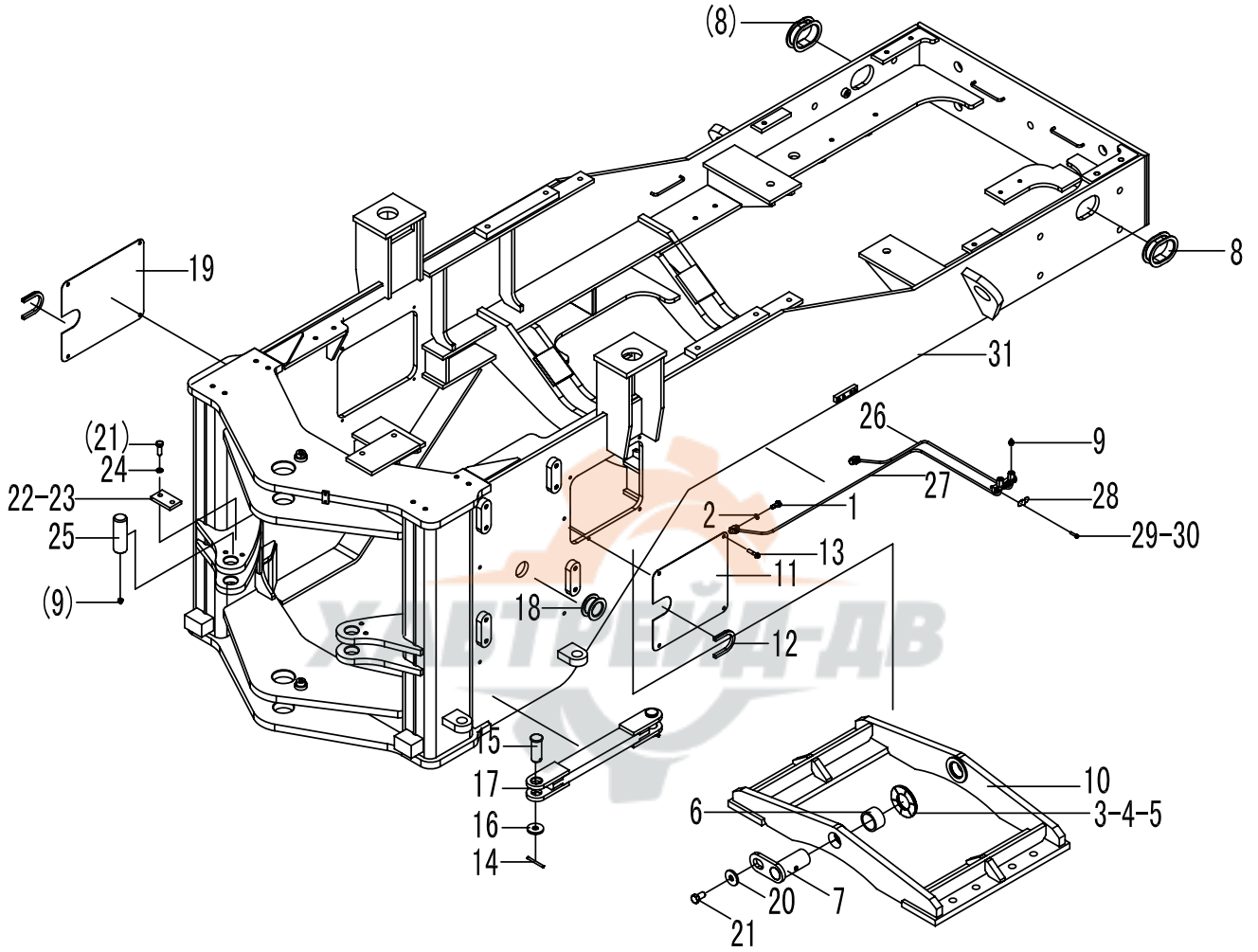

12

序号	代号	名称		数量	备注
KEY	PART NO.	DESCRIPTION		QTY	REMARKS
1	2925000029	通油螺栓	OIL BOLT	2	
2	2925000030	垫片	SPACER	4	
3	2927000105	调整垫片	ADJUST SPACER	2	
4	2927000106	调整垫片	ADJUST SPACER	2	
5	2927000107	调整垫片	ADJUST SPACER	2	
6	2927000783	套	BUSH	2	
7	4043000202	销轴 LGB301-50d9*62R*120G-40Cr	PIN LGB301-50d9*62R*120G-40Cr	2	
8	2927000003	走线胶套	RUBBER SLEEVE	2	
9	4030000065	油杯 JB7940.1-M10*1	GREASE NIPPLE JB7940.1-M10*1	4	
10	2927000784	副车架	OSCILLATING FRAME	1	
11	2927000756	盖板	HOOD	1	
12	2927000779	橡胶套	RUBBER BUSH	2	
13	4011000461	螺栓 GB16674-M8*16EpZn-8.8	BOLT GB16674-M8*16EpZn-8.8	8	
14	4016000040	开口销 GB91-6.3*50EpZn-Q235A	SPLIT PIN GB91-6.3*50EpZn-Q235A	2	
15	4016000136	销轴 GB882-B30*75EpZn-35	PIN GB882-B30*75EpZn-35	2	
16	4015000119	垫圈 GB97.1-30EpZn-300HV	WASHER GB97.1-30EpZn-300HV	2	
17	2927000793	车架固定连杆	MOUNT BAR	1	
18	2927000755	走线胶套	RUBBER SLEEVE	1	
19	2927000763	盖板	HOOD	1	
20	4040000001	垫圈 LGB001-12	WASHER LGB001-12	2	
21	4011000197	螺栓 GB5783-M12*25EpZn-8.8	BOLT GB5783-M12*25EpZn-8.8	6	
22	2925000111	卡板	PLATE	2	
23	2925000112	卡板	PLATE	2	
24	4015000026	垫圈 GB93-12-65Mn	WASHER GB93-12-65Mn	4	
25	2927000797	后转向销	REAR PIN OF STEERING CYLINDER	2	
26	2927000775	后输油管	REAR OIL TUBE	1	
27	2927000777	前输油管	FRONT OIL TUBE	1	
28	2925000031	管夹	PIPE CLIP	2	
29	4014000024	螺钉 GB818-M6*10EpZn-4.8	SCREW GB818-M6*10EpZn-4.8	4	
30	4015000035	垫圈 GB93-6-65Mn	WASHER GB93-6-65Mn	4	
31	2926000837	后车架	REAR FRAME	1	

配重铁总成
COUNTER WEIGHT

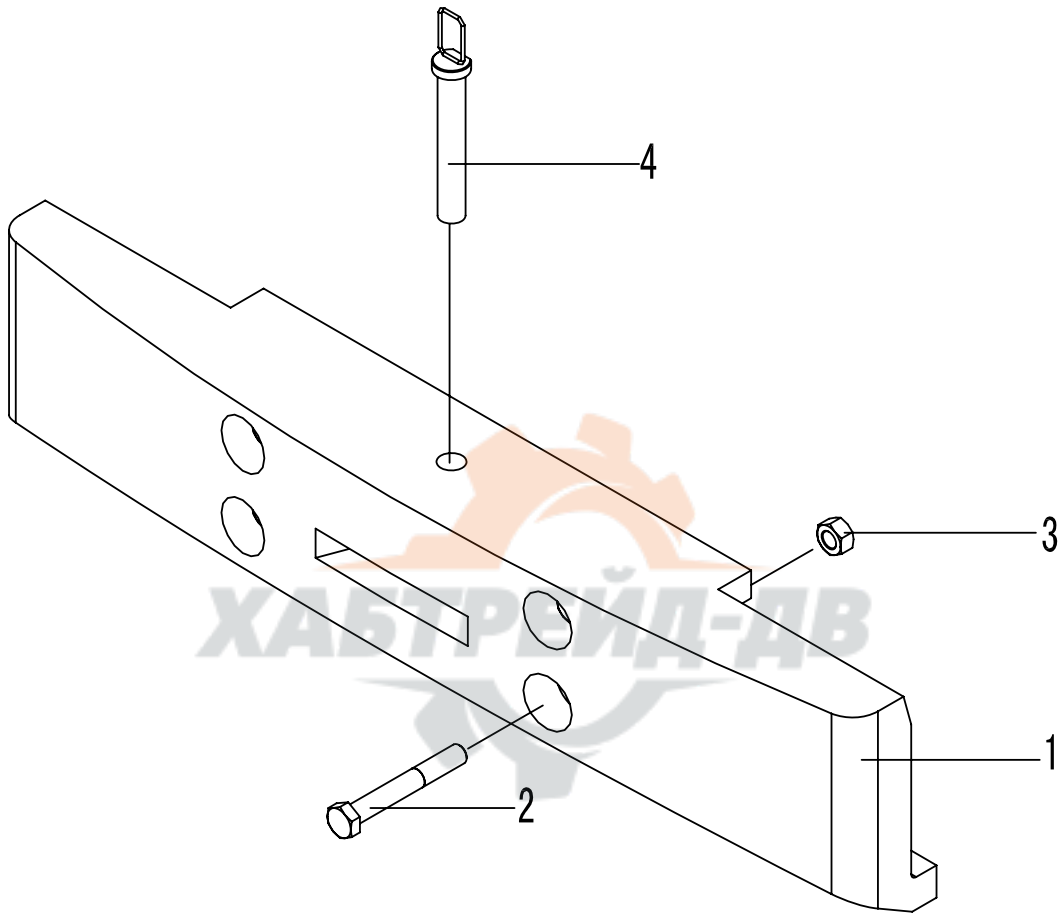

序号	代号	名称		数量	备注
KEY	PART NO.	DESCRIPTION		QTY	REMARKS
1	2928000402	平衡铁	COUNTER WEIGHT	1	HT100
2	4011000120	螺栓 GB5785-M30*2*215-8.8	BOLT GB5785-M30*2*215-8.8	4	
3	4013000064	螺母 GB889.2-M30*2-8	NUT GB889.2-M30*2-8	4	
4	2928000754	牵引销	TRACTIVE PIN	1	部件



J 驾驶室 CAB GROUP



山东临工工程机械有限公司
SHANDONG LINGONG CONSTRUCTION MACHINERY LTD.

J1

驾驶室总成 CAB GROUP

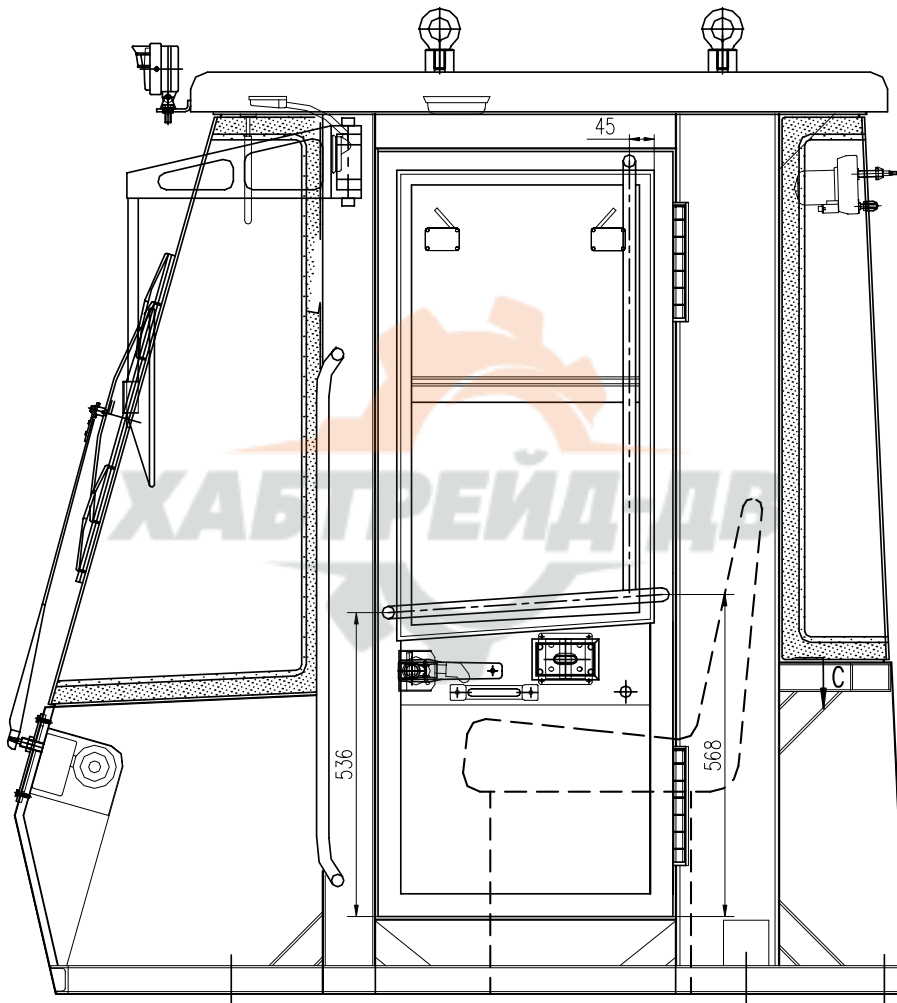

J1

序号	代号	名称	数量	备注
KEY	PART NO.	DESCRIPTION	QTY	REMARKS
1	4190000157	驾驶室 LG953E (CD) CAB GROUP LG953E (CD)	1	部件



J2

仪表盘总成 PANEL ASS'M

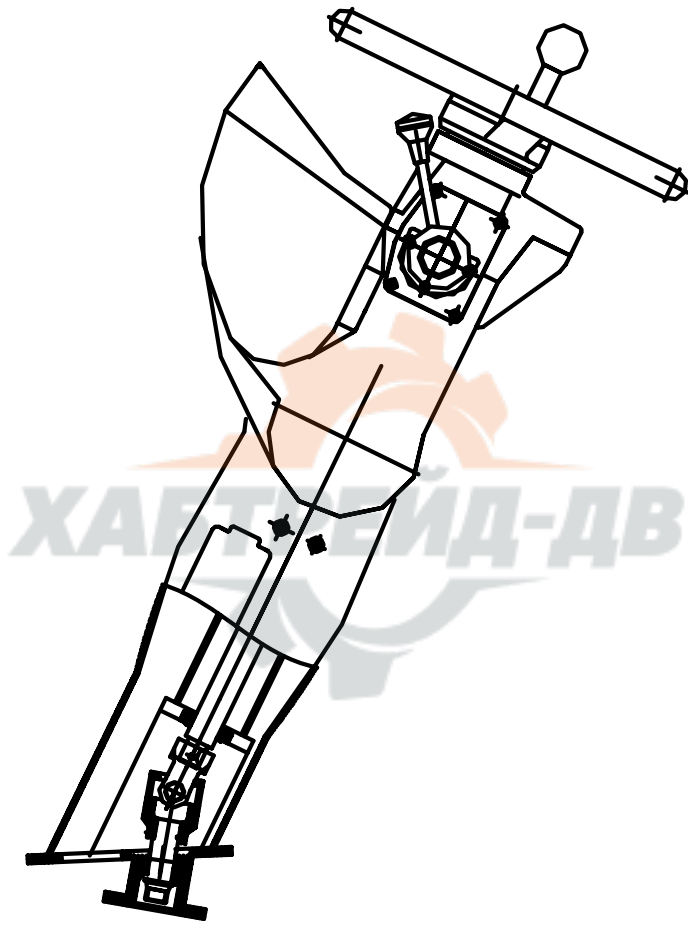

J2

序号	代号	名称	数量	备注
KEY	PART NO.	DESCRIPTION	QTY	REMARKS
1	2937000782	仪表盘总成 Y938KM PANELY938KM	1	



J3

座椅支架总成 SEAT ASSEMBLY

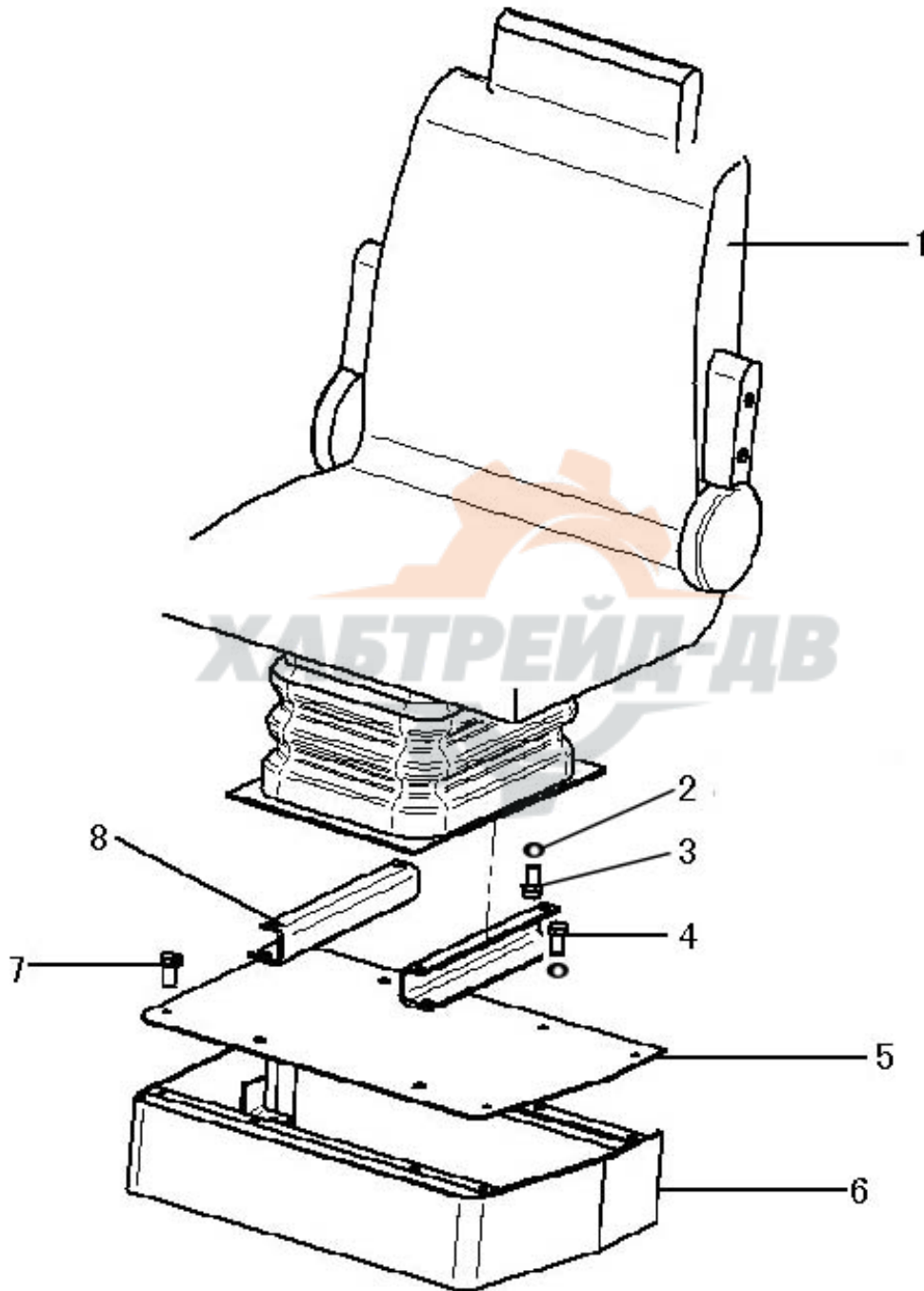

J3

序号	代号	名称		数量	备注
KEY	PART NO.	DESCRIPTION		QTY	REMARKS
1	4190000072	座椅 CS-B	DRIVER SEAT CS-B	1	部件
2	4015000072	垫圈 GB97. 1-8EpZn-300HV	WASHER	8	
3	4011000137	螺栓 GB16674-M12*20EpZn-8. 8	BOLT GB16674-M12*20EpZn-8. 8	4	
4	4011000105	螺栓 GB5783-M8*20EpZn-8. 8	BOLT GB5783-M8*20EpZn-8. 8	4	
5	2930000003	盖板	COVER	1	Q235A
6	2930000002	座椅支架	BRACKET	1	部件
7	4011000458	螺栓 GB16674-M8*20Ep. Zn-8. 8	BOLT GB16674-M8*20Ep. Zn-8. 8	8	
8	2930000004	槽钢	SUPPORT	2	Q235A



K 覆盖件系统
COVER SYSTEM



山东临工工程机械有限公司
SHANDONG LINGONG CONSTRUCTION MACHINERY LTD.

K1

发动机罩总成

HOOD OF DIESEL ENGINE ASSEMBLY

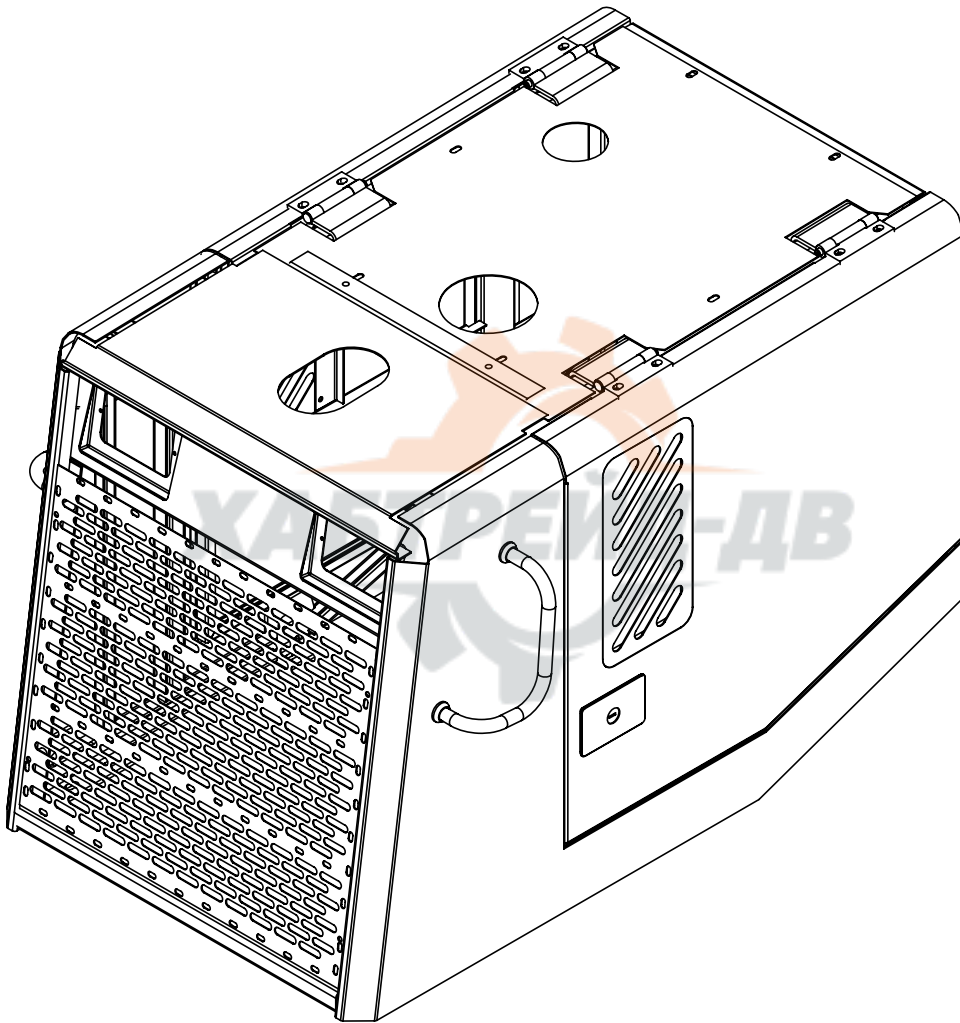

K1

序号	代号	名称	数量	备注
KEY	PART NO.	DESCRIPTION	QTY	REMARKS
1	2933001095	发动机罩	1	HOOD OF DIESEL ENGINE



K2

左台架总成

LEFT BENCH GROUP

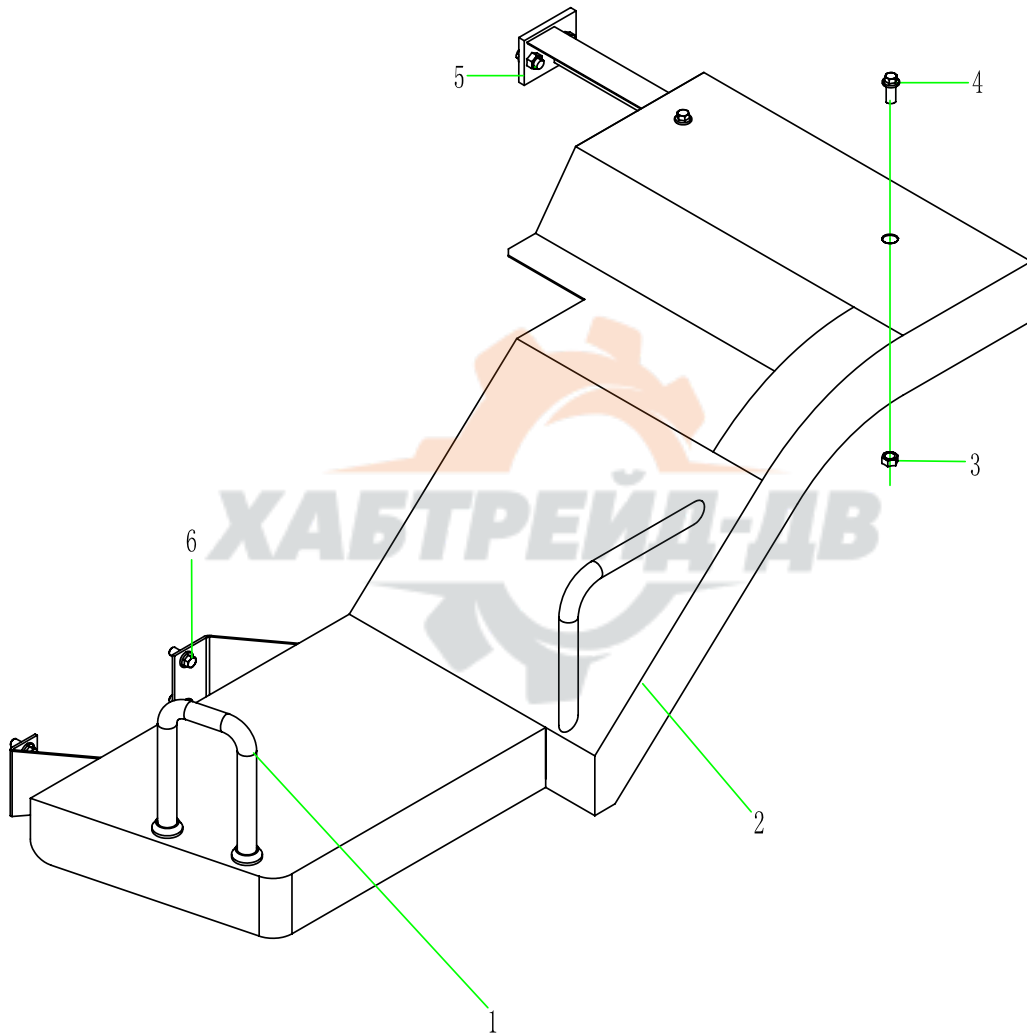

K2

序号	代号	名称		数量	备注
KEY	PART NO.	DESCRIPTION		QTY	REMARKS
1	2120900921	前扶手	FRONT HANDRAIL	1	
2	2934000870	左台架	LEFT BENCH	1	
3	4013000011	螺母 GB6170-M12EpZn-8	NUT GB6170-M12EpZn-8	2	
4	4011000560	螺栓 GB16674-M12*25EpZn-8.8	BOLT GB16674-M12*25EpZn-8.8	6	
5	2120900030	左支承架	LEFT SUPPORT FRAME	1	
6	4011000137	螺栓 GB16674-M12*20EpZn-8.8	BOLT GB16674-M12*20EpZn-8.8	4	



K3

右台架总成 RIGHT BENCH GROUP

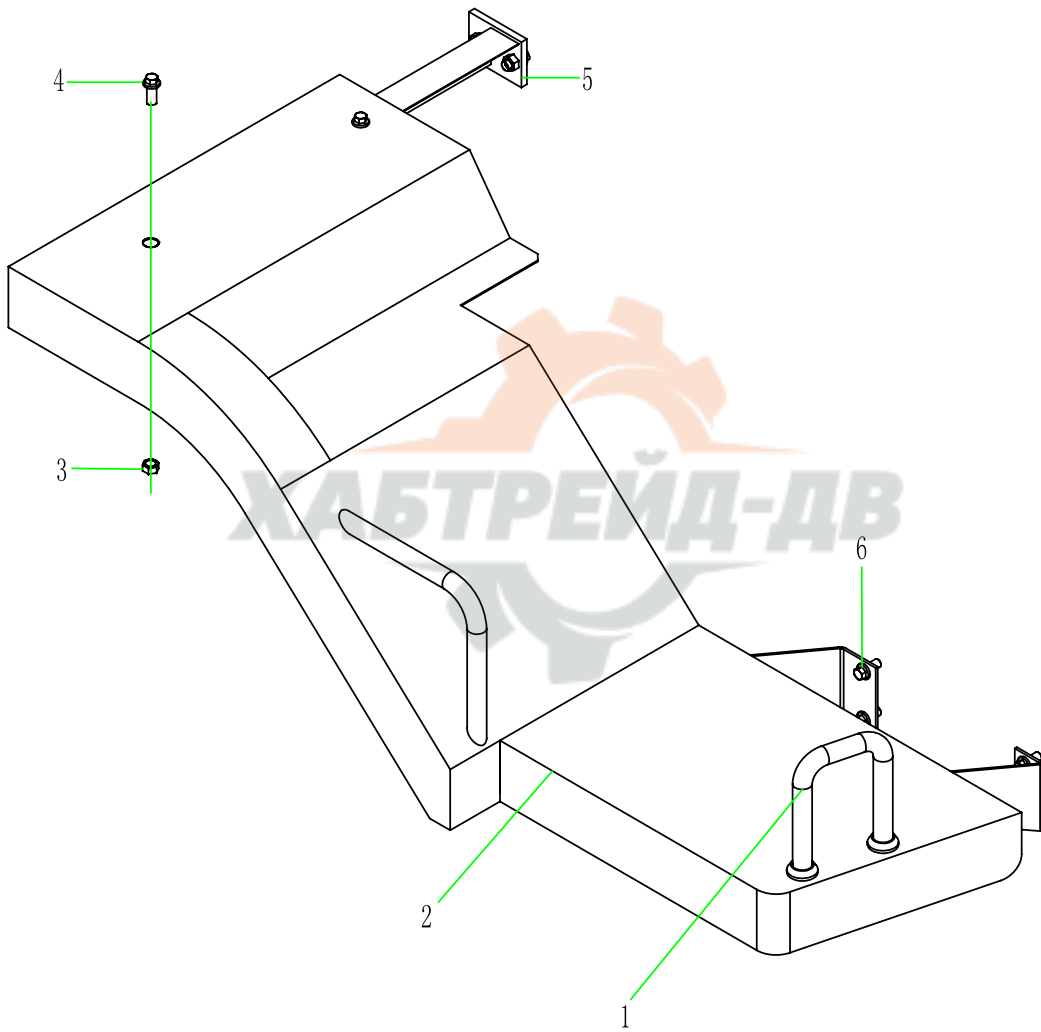

K3

序号	代号	名称	数量	备注
KEY	PART NO.	DESCRIPTION	QTY	REMARKS
1	2120900921	前扶手	1	FRONT HANDRAIL
2	2934000851	右台架	1	RIGHT BENCH
3	4013000011	螺母 GB6170-M12 EpZn-8	2	NUT GB6170-M12 EpZn-8
4	4011000560	螺栓 GB16674-M12*25EpZn-8.8	6	BOLT GB16674-M12*25EpZn-8.8
5	2120900056	右支承架	1	RIGHT SUPPORT FRAME
6	4011000137	螺栓 GB16674-M12*20EpZn-8.8	4	BOLT GB16674-M12*20EpZn-8.8



K4

左、右灯架

LEFT RIGHT LAMP FRAME

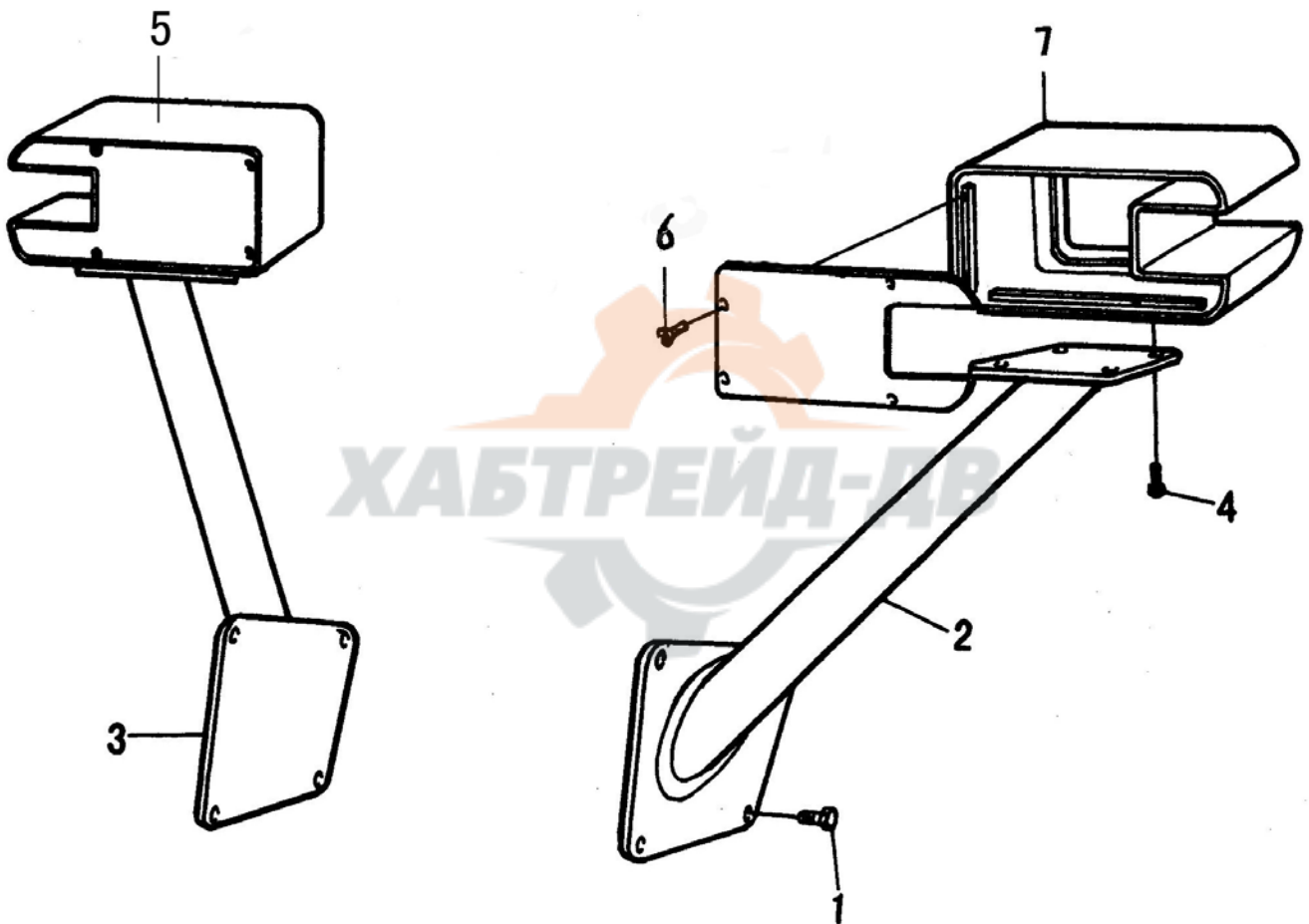

K4

序号	代号	名称		数量	备注
KEY	PART NO.	DESCRIPTION		QTY	REMARKS
1	4011000479	螺栓 GB16674-M12*30-Ep. Zn-8. 8	BOLT GB16674-M12*30-Ep. Zn-8. 8	6	
2	2120900532	左灯架	LEFT BRACKET OF LAMP	1	
3	2120900533	右灯架	RIGHT BRACKET OF LAMP	1	
4	4011000474	螺栓 GB16674-M10*25-Ep. Zn-8. 8	BOLT GB16674-M12*30-Ep. Zn-8. 8	6	
5	4130000205	前右组合灯 LFRD-24V	RIGHT FRONT ASSEMBLED LAMP LFRD-24V	1	
6		螺钉	SCREW	8	灯上自带
7	4130000204	前左组合灯 LFLD-24V	LEFT FRONT ASSEMBLED LAMP LFLD-24V	1	



K5

左、右前挡泥瓦

LEFT RIGHT FRONT FENDER

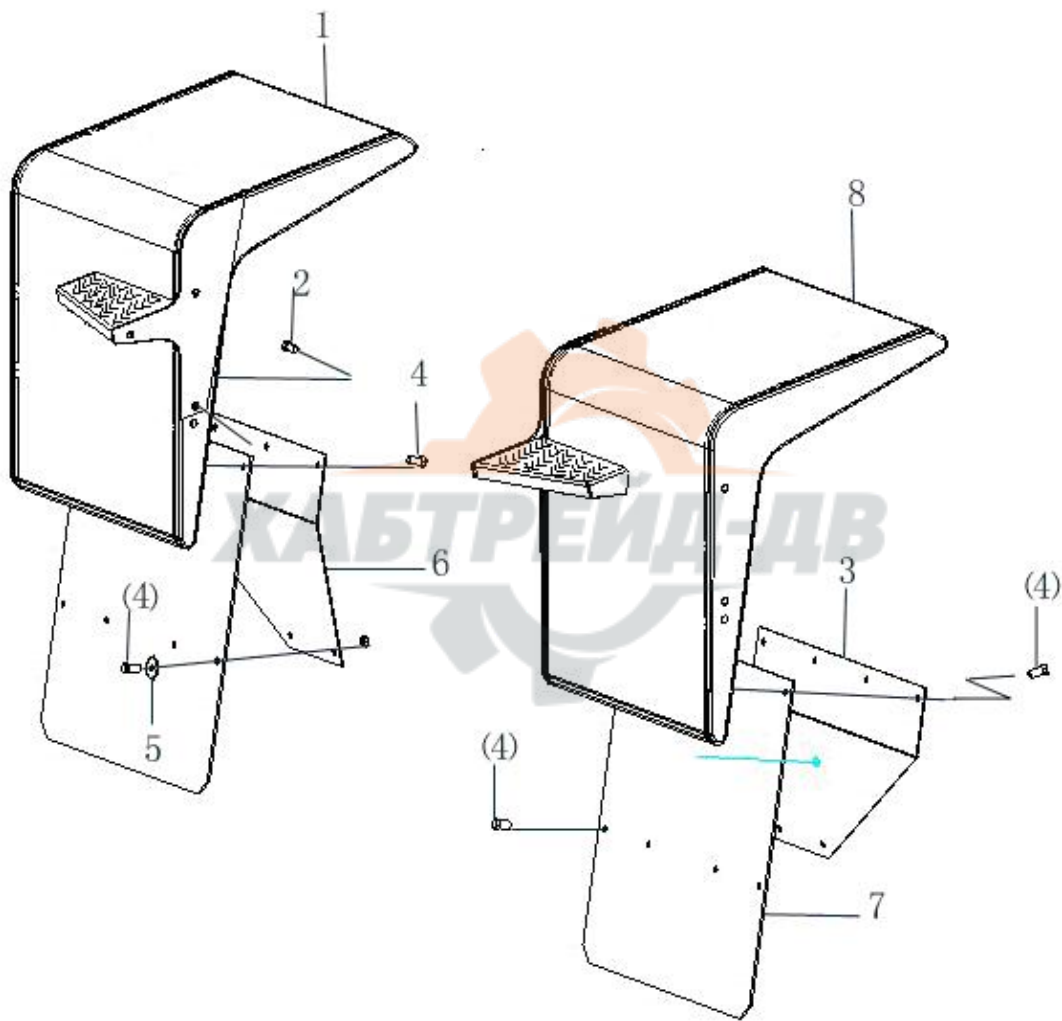

K5

序号	代号	名称		数量	备注
KEY	PART NO.	DESCRIPTION		QTY	REMARKS
1	2120900133	左前挡泥瓦	LEFT FRONT FENDER	1	
2	4011000560	螺栓 GB16674-M12*25Ep • Zn-8. 8	BOLT GB16674-M12*25Ep • Zn-8. 8	6	
3	2925000062	支撑板	PLATE	1	
4	4011000474	螺栓 GB16674-M10*25Ep • Zn-8. 8	BOLT GB16674-M10*25Ep • Zn-8. 8	12	
5	2925000042	垫圈	WASHER	4	
6	2925000068	支撑板	PLATE	1	
7	2925000063	橡胶板	RUBBER FENDER	2	
8	2120900138	右前挡泥瓦	RIGHT FRONT FENDER	1	



K6

电瓶箱总成 BATTERY CASE ASSEMBLY

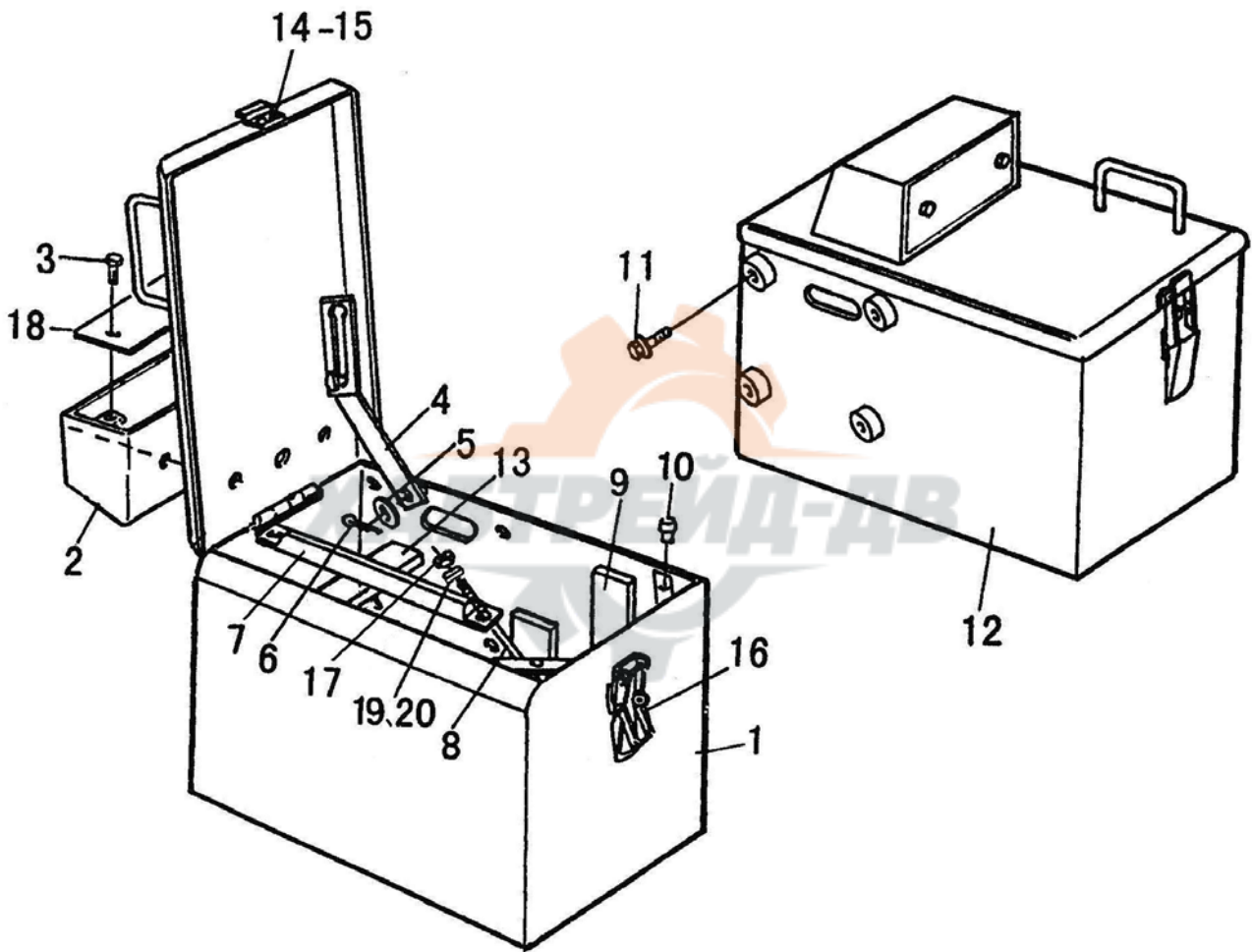

K6

序号	代号	名称		数量	备注
KEY	PART NO.	DESCRIPTION		QTY	REMARKS
1	2934000931	右电瓶箱	RIGHT BATTERY BOX	1	
2	2934000206	后转向灯罩	LAMP BOX	2	
3	4011000474	螺栓 GB16674-M8*16-EpZn-8.8	BOLT GB16674-M8*16-EpZn-8.8	4	
4	2934000909	拉杆	LINK ASSEM	2	
5	4015000168	垫圈 GB97.1-12Ep.Zn-300HV	WASHER GB97.1-12EpZn-300HV	4	
6	4016000035	开口销 GB91-4*20-EpZn-Q235A	SPLIT PIN GB91-4*20-EpZn-Q235A	2	
7	2934000911	锁紧角钢	LOCKING ANGLE BAR	2	
8	2934000912	锁紧螺杆	CLAMP BOLT	4	
9	2934000908	侧胶垫	RUBBER PAD	4	
10	2934000910	橡胶塞	RUBBER PLUG	4	
11	4011000150	螺栓 GB16674-M16*35-EpZn-8.8	BOLT GB16674-M16*35-EpZn-8.8	8	
12	2934000907	左电瓶箱	LEFT BATTERY BOX	1	
13	2934000013	下胶垫	RUBBER PAD	4	
14	4014000023	螺钉 GB818-M5*10-EpZn-4.8	SCREW GB818-M5*10-EpZn-4.8	10	
15	4015000110	垫圈 GB97.1-5EpZn-300HV	WASHER GB97.1-5EpZn-300HV	10	
16	4190000025	扣锁 NBXS1013	LOCK NBXS1013	2	
17	4013000033	螺母 GB6170-M8EpZn-8	NUT GB6170-M8EpZn-8	4	
18	2934000033	板	PLATE	2	
19	4015000036	垫圈 GB93-8-65Mn	WASHER GB93-8-65Mn	4	
20	4015000072	垫圈 GB97.1-8EpZn-300HV	WASHER GB97.1-8EpZn-300HV	4	

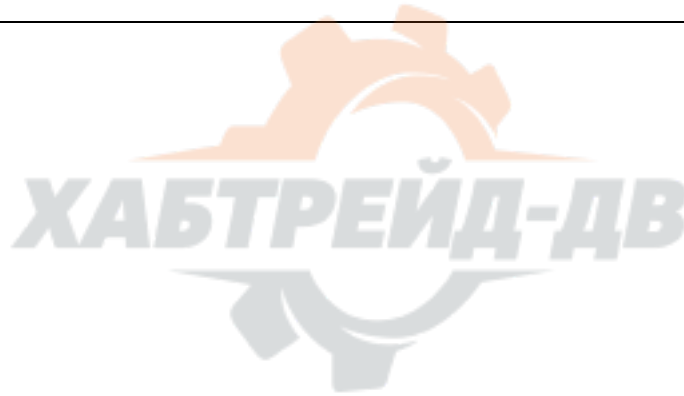

L 空调系统
AIR CONDITIONER SYSTEM



山东临工工程机械有限公司
SHANDONG LINGONG CONSTRUCTION MACHINERY LTD.

空调系统 AIR CONDITIONER SYSTEM

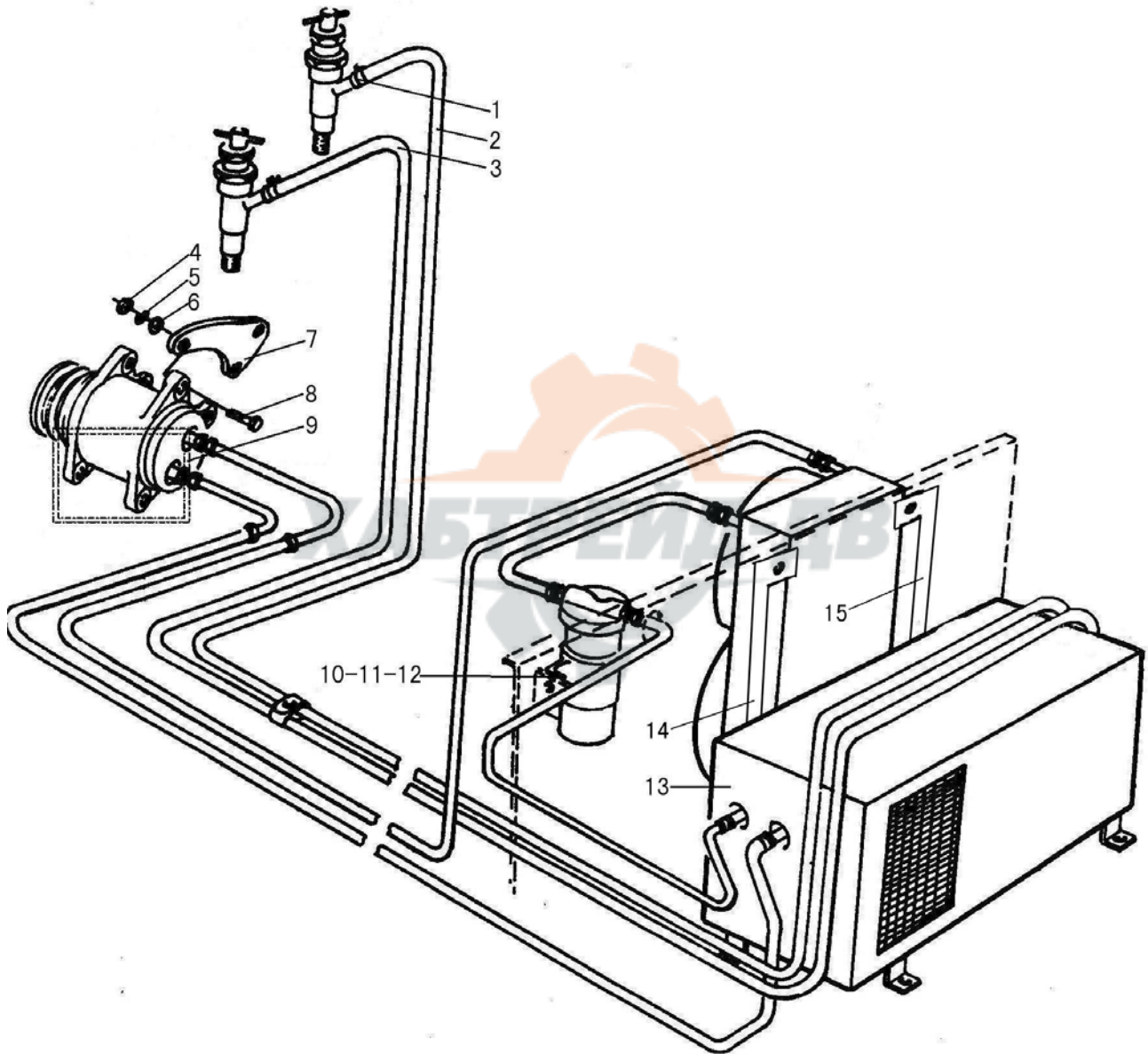

L1

序号	代号	名称		数量	备注
KEY	PART NO.	DESCRIPTION		QTY	REMARKS
1	4120000075	胶管夹箍 Q/ZB251-1/2”	CLAMP Q/ZB251-1/2”	4	部件
2	4120000049	胶管 JB8406-B16X2600	RUBBER TUBE JB8406-B16X2600	1	耐油橡胶
3	4120000119	胶管 JB8406-B16X2300	RUBBER TUBE JB8406-B16X2300	1	耐油橡胶
4	4013000007	螺母 GB6170-M10EpZn-8	NUT GB6170-M10EpZn-8	8	
5	4015000162	垫圈 GB97.1-10EpZn-300HV	LOCK WASHER GB97.1-10EpZn-300HV	8	
6	4015000025	垫圈 GB93-10-65Mn	LOCK WASHER GB93-10-65Mn	8	
7	2935000811	托板	SUPPORT PLATE	2	Q235A
8	4011000085	螺栓 GB5783-M10*35EpZn-8.8	BOLT GB5783-M10*35EpZn-8.8	8	
9	2935000781	压缩机支架	COMPRESSOR SUPPORT	1	部件
10	4011000474	螺栓 GB16674-M10*25EpZn-8.8	BOLT GB16674-M10*25EpZn-8.8	8	
11	4013000007	螺母 GB6170-M10EpZn-8	NUT GB6170-M10EpZn-8	4	
12	2935000788	储液罐支架	DRYER BEARING	1	Q235A
13	4190000472	空调 CD30L17	AIR CONDITIONER CD30L17	1	部件
14	2935000780	前支板	FRONT SUPPORTING PLATE	1	
15	2935000779	后支板	REAR SUPPORTING PLATE	1	



M 电气系统
ELECTRIC SYSTEM



山东临工工程机械有限公司
SHANDONG LINGONG CONSTRUCTION MACHINERY LTD.

M1

电气系统 ELECTRIC SYSTEM

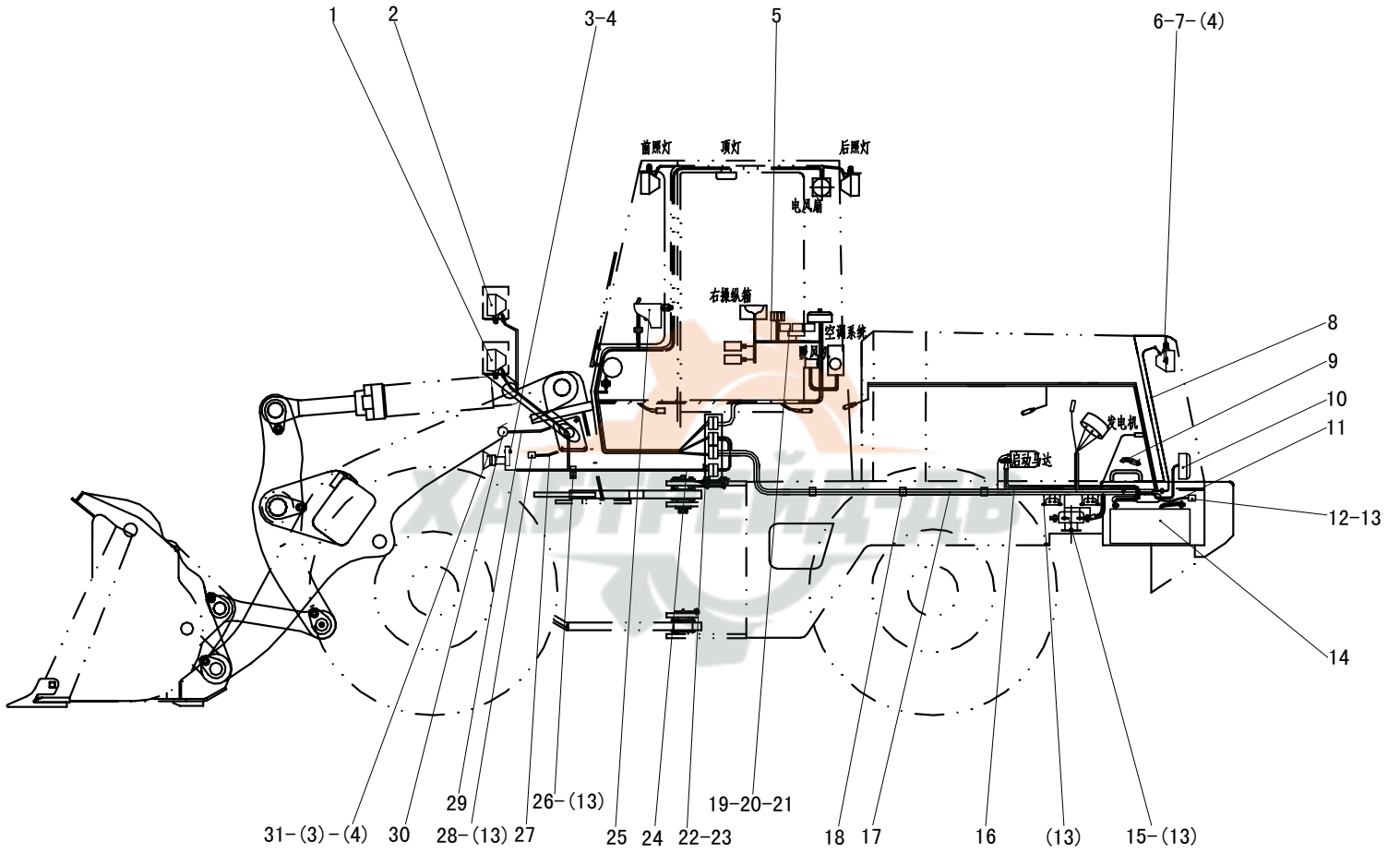

M1

序号	代号	名称		数量	备注
KEY	PART NO.	DESCRIPTION		QTY	REMARKS
1	4130000204	前左组合灯 LFLD-24V	LEFT FRONT HEAD LAMP	1	
2	4130000205	前右组合灯 LFRD-24V	RIGHT FRONT HEAD LAMP	1	
3	4014000024	螺钉 GB818-M6*10EpZn-4.8	SCREW GB818-M6*10EpZn-4.8	2	
4	4015000207	垫圈 GB97.1-6EpZn-300HV	WASHER GB97.1-6EpZn-300HV	6	
5	2937000776	右操纵箱线束总成	RIGHT STEERING WIRING HARNESS	1	部件
6	4130000211	后大灯 LRD-24V	REAR LARGE LAMP LRD-24V	2	
7	4014000026	螺钉 GB818-M6*16EpZn-4.8	SCREW GB818-M6*16EpZn-4.8	4	
8	2937000404	后罩线束	COVER HARNESS	1	部件
9	2937000405	蓄电池接地线	EARTH WIRE	1	部件
10	4130000213	后尾灯 LRTD-24V	REAR LAMP LRTD-24V	2	
11	2937000407	启动马达线	LINE FROM SWITCH TO MOTOR	1	部件
12	4130000121	倒车蜂鸣器 KSHM-12F4	ANNUNCIATOR KSHM-12F4	1	
13	4011000461	螺栓 GB16674-M8*16EpZn-8.8	BOLT GB16674-M8*16EpZn-8.8	15	
14	4130000057	蓄电池 6-QW-120B	BATTERY 6-QW-120B	2	
15	4130000005	蓄电池继电器 DK2312A	MAIN SWITCH OF POWER SOURCE	1	
16	2937000406	蓄电池串联线	STORAGE BATTERY WIRE	1	部件
17	2937000779	后车架线束	BODY WIRING HARNESS	1	部件
18	4190000020	扎丝 LG13-ZS4*250	BINDING WIRE	60	
19	4130000011	中间继电器 JD2914	MIDDLE RELAY JD2914	5	
20	4014000048	螺钉 GB818-M5*12EpZn-4.8	SCREW GB818-M5*12EpZn-4.8	5	
21	4015000110	垫圈 GB97.1-5EpZn-300HV	WASHER GB97.1-5EpZn-300HV	5	
22	4014000087	螺钉 GB818-M4*16EpZn-4.8	SCREW GB818-M4*16EpZn-4.8	14	
23	4015000135	垫圈 GB97.1-4EpZn-300HV	WASHER GB97.1-4EpZn-300HV	14	
24	2937000781	前车架线束	BODY WIRING HARNESS	1	部件
25	2937000782	仪表盘总成 Y938KM	PANEL Y938KM	1	部件
26	2935000002	管夹	PIPE NIP	5	部件
27	2937000783	快换装置线束	RAPIDNESS DEVICE WIRING HARNESS	1	部件
28	4130000031	倒车蜂鸣器 FM211	ANNUNCIATOR FM211	1	
29	2937000784	自动找平装置线束	SELFLEVELING DEVICE WIRING HARNESS	1	部件
30	4130000010	接近开关 J7-D10B1	PROXIMITY SWITCH	2	
31	4130000009	双音盆形喇叭 DL125-24V	ELECTRIC HORN DL125-24V	1	