

可调整转向柱 STEERING COLUMN ADJUSTABLE

序号  
NO

k

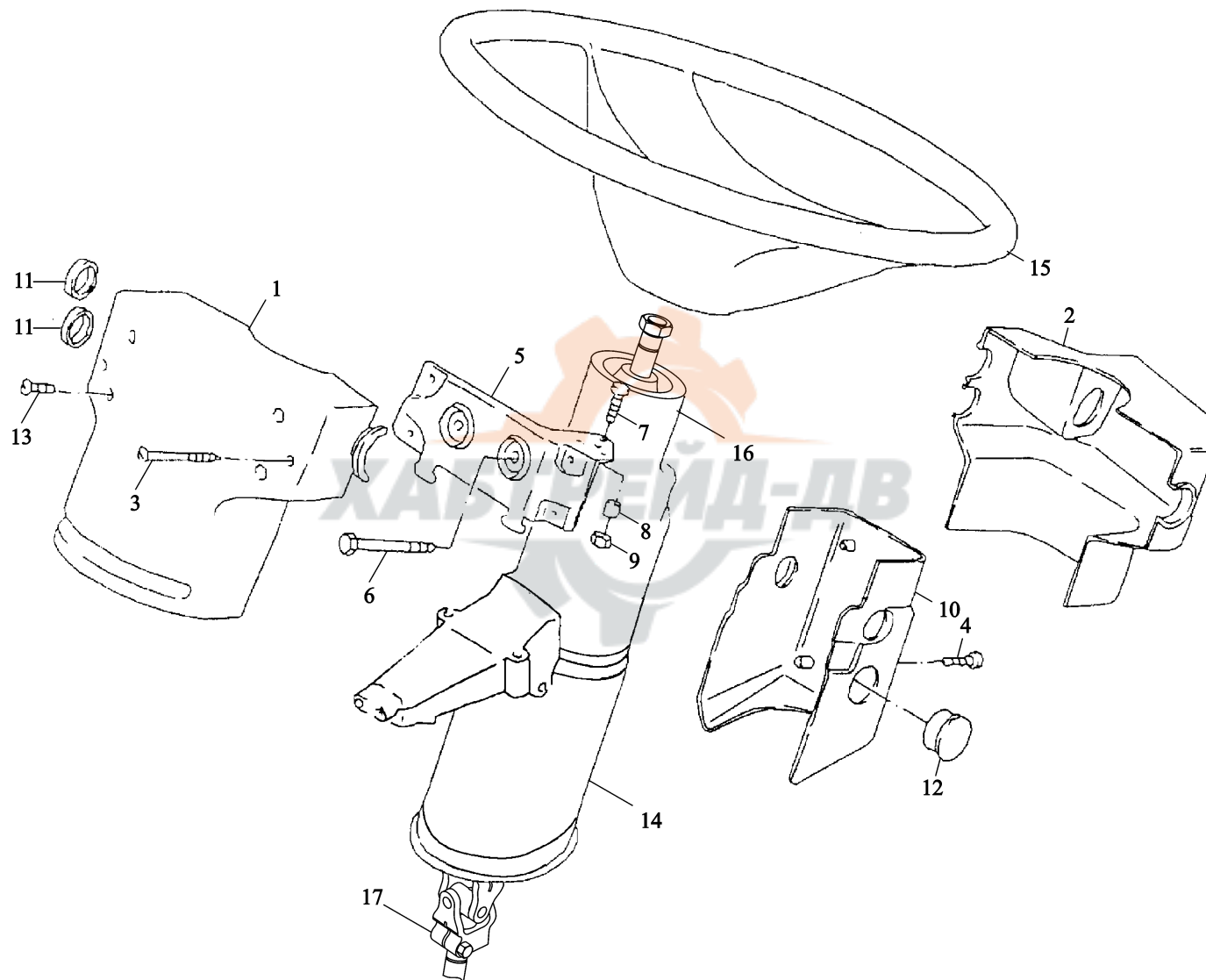

1	81.46113.0095	护 盖	Protection cover	1	
2	81.46113.0094	护 盖	Protection cover	1	
3	06.07158.1511	自攻螺钉	Self-tapping screw	2	ST4.2×50C-H-A3R
4	06.07095.0204	自攻螺钉	Self tapping screw	4	AEM4×12-A3R
5	81.46145.0014	支 架	Bracket	1	
6	81.90490.0443	带外扭矩的保险螺栓	Safety bolt with external torx	2	
7	06.04201.2513	盘头螺钉	Pan-head screw	1	M5×30-4.8-H-MAN183-B1
8	81.95801.0071	滚 子	Bush	1	6.1×10×16-POM
9	06.11240.2102	六角锁紧螺母	Locking nut	1	AM5-8-A2C
10	81.46113.0085	转向柱罩壳	Steering column cover	1	
11	81.46113.0088	罩	Cover black plastic	2	
12	81.96410.0560	盖	Cover	1	
13	06.07095.0207	自攻螺钉	Self-tapping screw	4	56×20
14	81.46132.0074	波纹管总成	Ripple pipe assy	1	
	81.46132.0076	波纹管总成	Ripple pipe assy	1	
15	51.46430.0069	方向盘	Handl wheel	1	右置车 to right
16	DZ9112470001	转向管柱总成	Steering column assy	1	
17	81.46122.6112	转向伸缩轴总成	Steering flex shaft assy	1	

# 液 压 装 置 ( 一 ) HYDRAULIC DEVICE I

序号 NO	件号 Part.No	
----------	---------------	--

备注 Remark
--------------

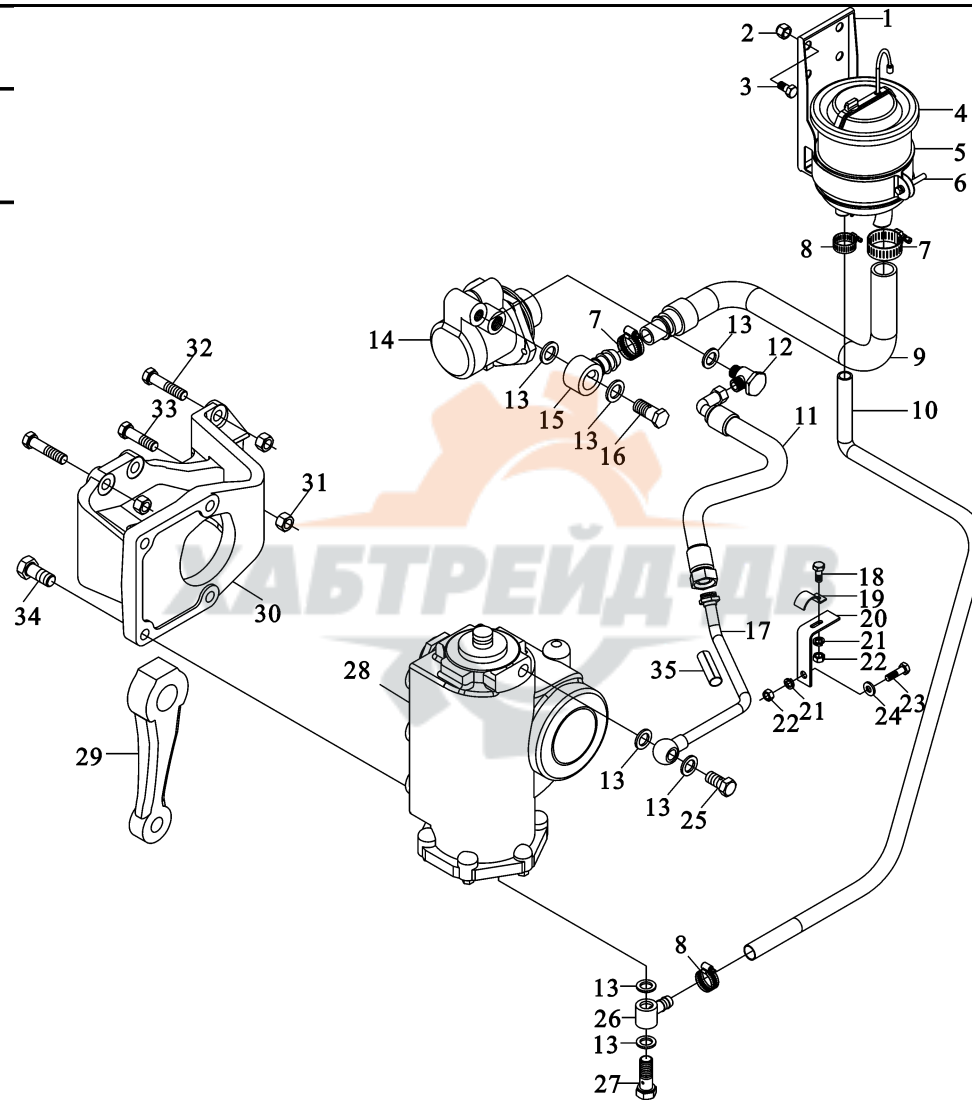

1	DZ9100470101	支架	Bracket	1		
2	Q33410	I 型全金属六角锁紧螺	Locking nut	2		
3	Q150B1020	母	Hex screw	2		
4	DZ9100470095	六角头螺栓	Oil container assy	1	4×2 6×4	
5	DZ9100470110	转向油罐总成	Fastening strap	1		
6	Q2140635	夹紧带总成	Hex screw	1		
7	Q67632	十字槽盘头螺钉	Clip	2		
8	Q676B25	B 型蜗杆传动式软管环	Clip	2		
9	DZ9100470017	箍	Hose	1		
10	DZ9100470014	C 型蜗杆传动式软管环	Rubber hose	1		
11	99100470107	成型软管	High pressure hose	1		
12	99100470110	带纤维夹层的橡胶软管	Nozzle	1		
13	90003098031		Seal washer	5		A26×31
14	DZ9100130028	高压软管	Hydraulic pump	1		420Ps
	DZ9100130037	旋转管接头	Hydraulic pump	1		
15	99100470076	密封垫圈	Nipple	1		
16	90003962651	转向油泵	Female screw	1		
17	DZ9118470026	转向油泵	Delivery line	1		8×4
	DZ9100470052	环形接头	Delivery line	1		
18	90003802321	空心螺栓	Hex screw	1		Q150B0616
19	38091360181	压油管总成	Clip	2		
20	39700350169	压油管总成	Bracket	1		
21	90003931082	六角头螺栓	Spring washer	3		Q40506
22	90003871232	管 夹	Nut	3		Q340B06

# 液 压 装 置 ( 一 ) HYDRAULIC DEVICE I

序号 NO	件号 Part.No	
----------	---------------	--

备注 Remark
--------------

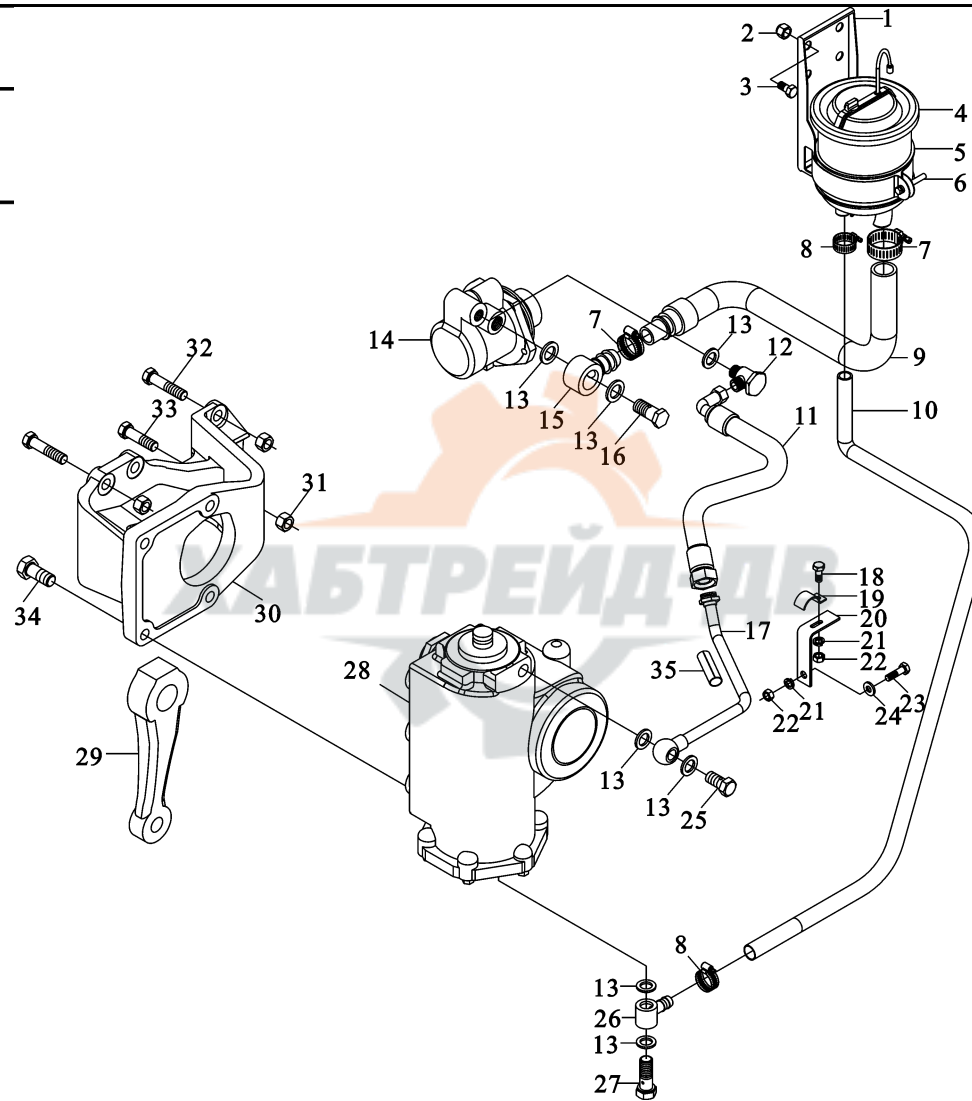

24	90003936101	大垫圈	Washer	3		Q40206
25	90003962632	空心螺栓	Female screw	1		
26	DZ9100470013	旋转管接头	Screwing	1		
27	250-3408017	空心螺栓	Female screw	1		
28	DZ9114470050J	转向器	Steering gear	1		进口
	J	转向器	Steering gear	1		国产沙市
	DZ9100470055	转向器	Steering gear	1		右置车
29	DZ9114470060	转向垂臂	Drop arm	1		
	DZ9100470005	转向垂臂	Drop arm	1		
	DZ9100470205	转向垂臂	Drop arm	1	8×4	
	99118470050	转向垂臂	Drop arm	1		右置车
30	DZ9100470206	转向器支架	Bracket	1	8×4	DZ9100470006
	DZ9100470213	转向器支架	Bracket	1		
	DZ9118470022	转向器支架	Bracket	1		右置车
31	DZ9100470214	自锁螺母	Locking nut	5		
32	90003888627	六角头螺栓	Hex screw	4		Q151B1670TF2
33	90003802848	六角头螺栓	Hex screw	1		
34	Q151B1655TF	六角头螺栓	Hex screw	5		
35	2	橡胶软管	Rubber hose	1		
	90003803964	15/21				
	1610060211					

# 双转向液压装置 (二) DOUBLE SHAFTS STEERING HYDRAULIC DEVICE II

双转向

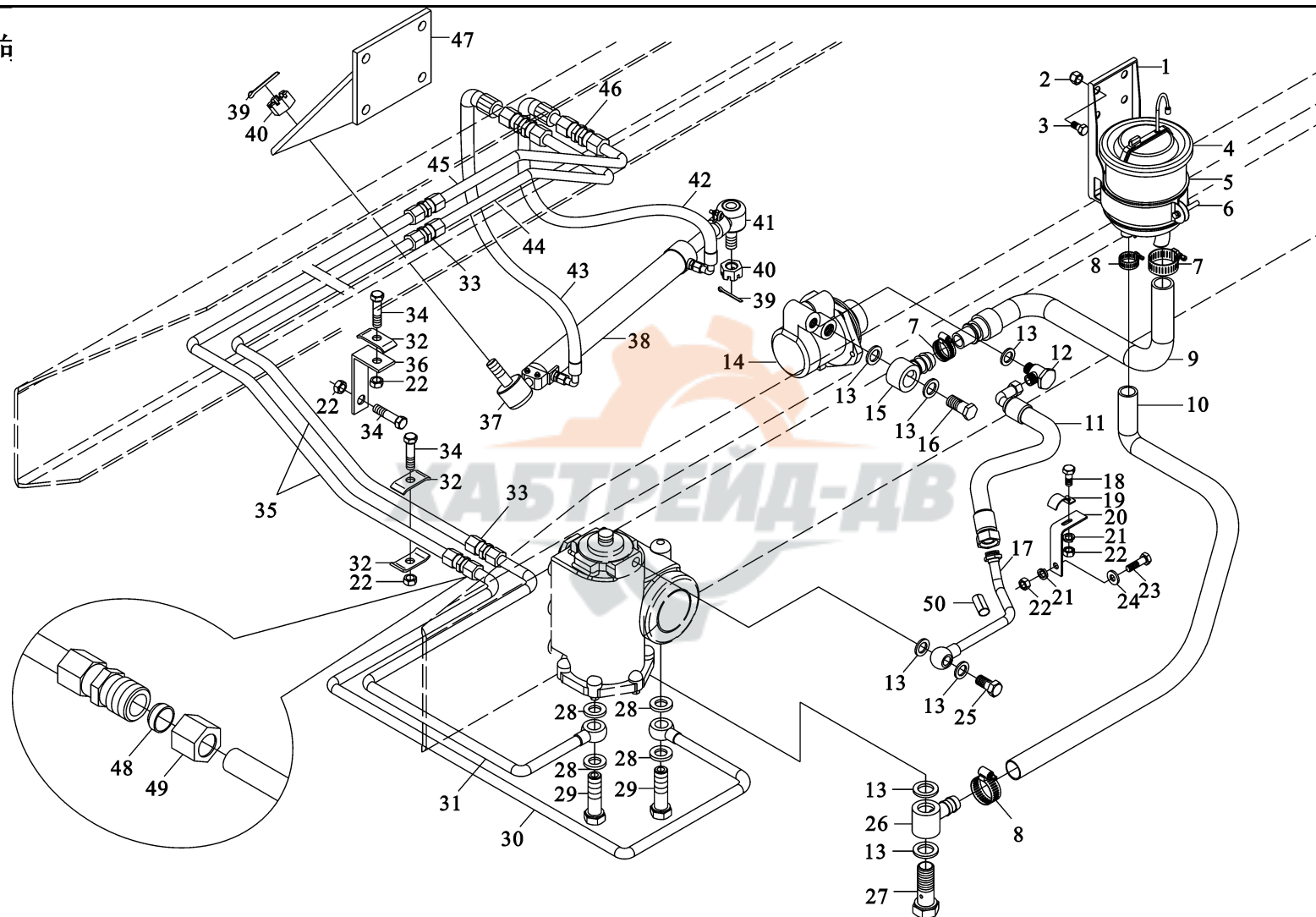

1	DZ9100470101	支 架	Bracket	1	
2	Q33410	I 型全金属六角锁紧螺	Locking nut	2	
3	Q150B1020	母	Hex screw	2	
4	69100470033	六角头螺栓	Oil container assy	1	
5	DZ9100470110	转向油罐总成	Fastening strap	1	
6	Q2140635	夹紧带总成	Pan-head screw	1	
7	Q67632	十字槽盘头螺钉	Clip	2	
8	Q676B25	B 型蜗杆传动式软管环	Clip	2	
9	DZ9100470017	箍	Hose	1	
10	99114470088	C 型蜗杆传动式软管环	Rubber hose	1	
11	99100470107	箍	High pressure hose	1	
12	99100470110	成型软管	Screwing	1	
13	90003098031	带纤维夹层的橡胶软管	Seal-washer	5	
14	DZ9100130037	高压软管	Hydraulic pump	1	420Ps
	DZ9100130028	旋转管接头	Hydraulic pump	1	
15	99100470076	密封垫圈	Nipple	1	
16	90003962651	转向油泵	Female screw	1	
17	DZ9100470026	转向油泵	Delivery line	1	8×4
18	Q150B0616	环形接头	Hex screw	1	
19	38091360181	空心螺栓	Clip	2	
20	39700350169	压油管总成	Bracket	1	
21	Q40506	六角头螺栓	Spring washer	3	
22	Q340B06	管 夹	Nut	3	
23	Q150B0625	角形支架	Hex screw	1	
24	Q40206	重型弹簧垫圈	washer	3	



# 双转向液压装置 (二) DOUBLE SHAFTS STEERING HYDRAULIC DEVICE II

双转向

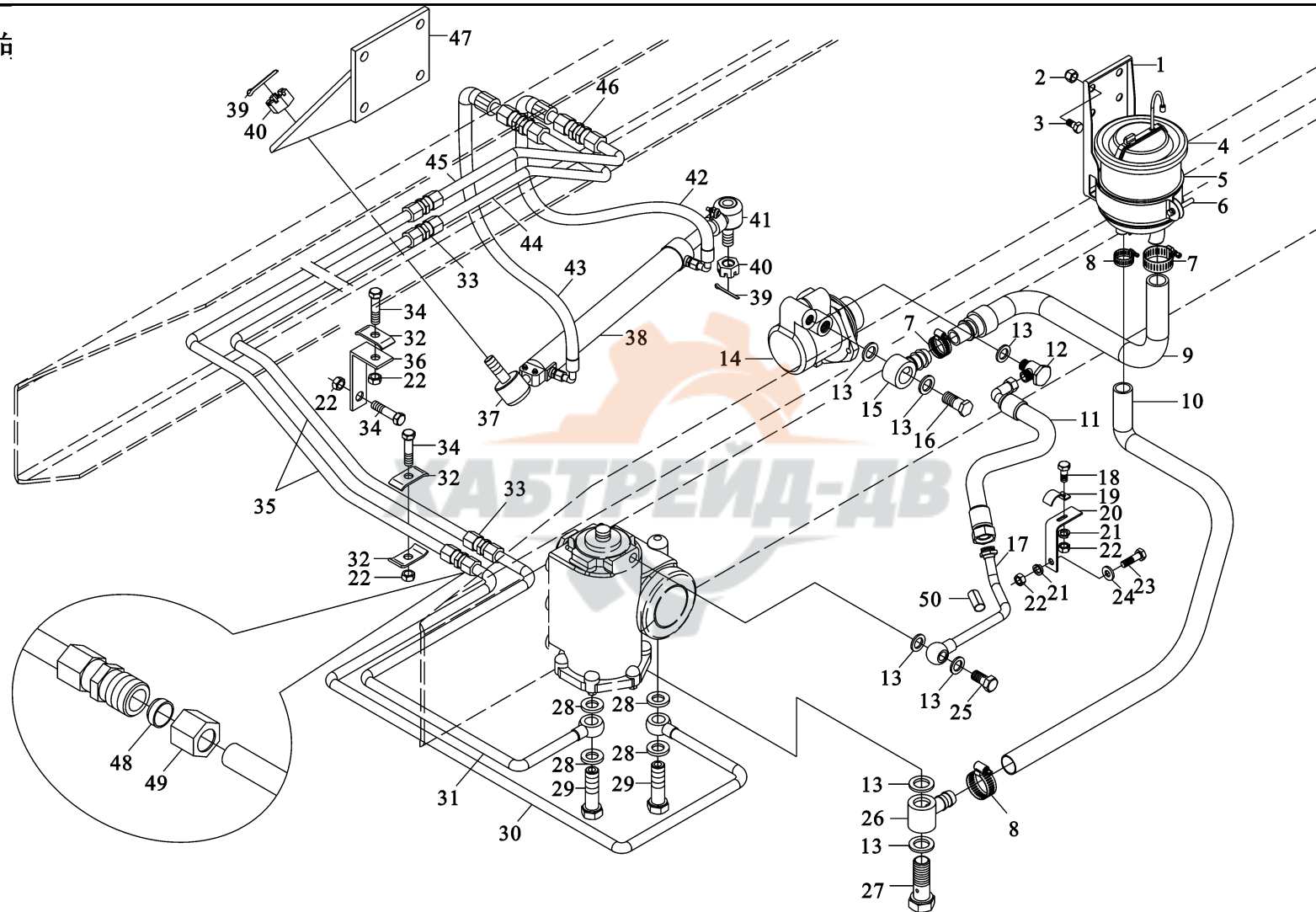

25	90003962632	空心螺栓	Female screw	1		
26	DZ9100470013	旋转管接头	Screwing	1		
27	250-3408017	空心螺栓	Famale screw	1		
28	90003098020	密封垫圈	Seal washer	4		
29	90003962632	空心螺栓	Female screw	2		
30	DZ9118470036	钢 管	Steel pipe	1		
31	DZ9118470034	钢 管	Steel pipe	1		
32	880 730187	管 夹	Clip	3		
33	6122-3406097-04	直通体接头	Nozzle	4		
34	Q150B0630	六角头螺栓	Hex screw	2		
35	DZ9118470044	钢 管	Steel pipe	2		
36	99012360440	角形支架	Bracket	1		
37	DZ9118470024	球型接头总成	Ball connector assy	1		
38	DZ9114470008	动力缸	Operating cylider	1		
39	Q5004036	开口销	Cotter pin	2		
40	90003872359	六角开槽螺母	Slit nut	2		
41	99018470025	球型接头总成	Ball connector assy	1		
42	99100470107	高压油管	Oil pipe	1		
43	DZ9100470108	高压油管	Oil pipe	1		
44	DZ9118470045	钢 管	Steel pipe	1		
45	DZ9118470046	钢 管	Steel pipe	1		
46	DZ9118470009	直通接头体	Nozzle	2		
47	99018510018	动力缸支架	Bracket	1		
48	90003559562	卡 套	Cutting ring	4		

转向油罐 STEERING OIL TANK



# 转向油罐

序号	NO
1	1

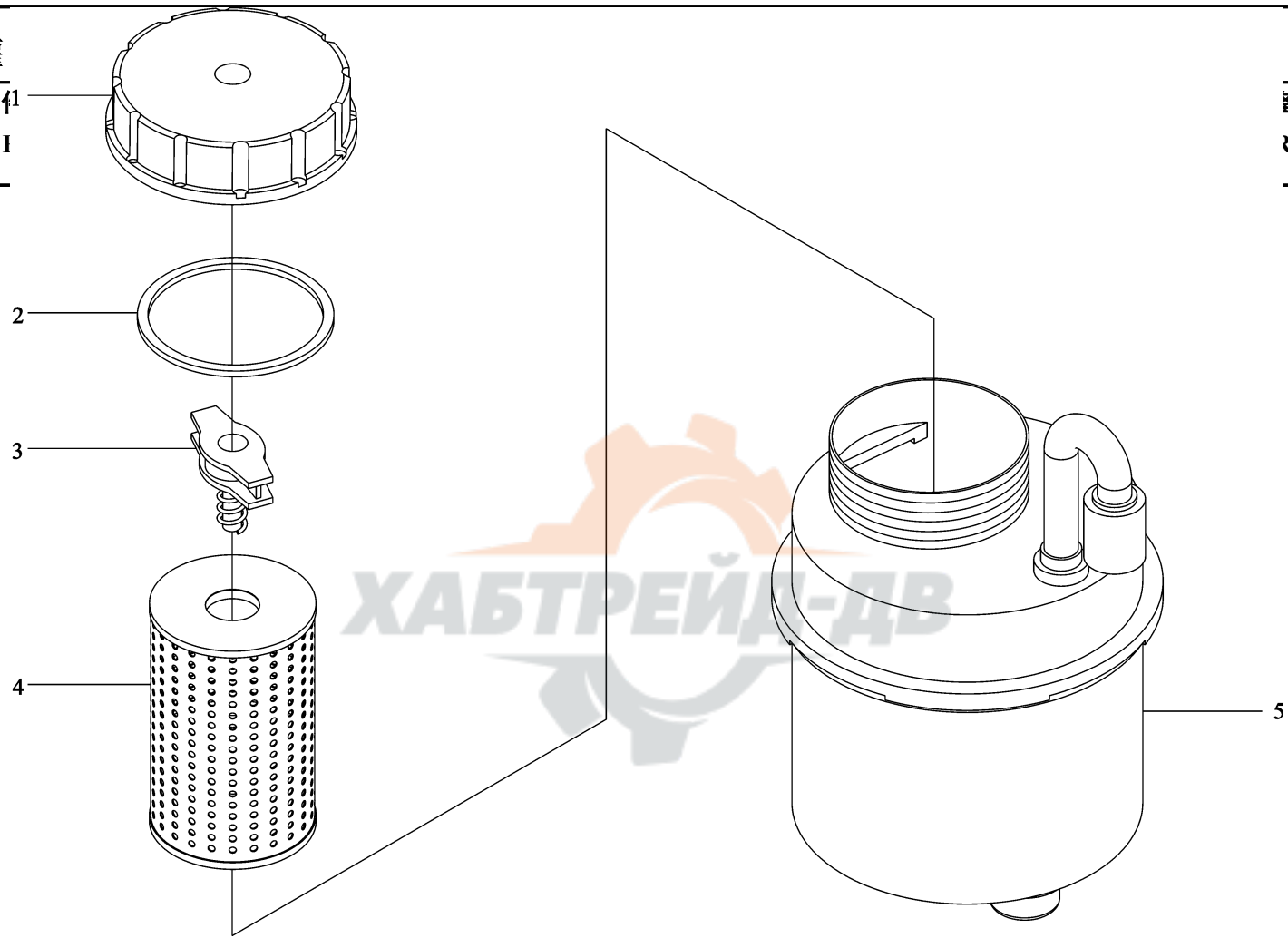

备注  
remark

1	6910047073	转向油罐螺盖	Oil container cover	1		
2	6910047072	密封环	Seal ring	1		
3	6910047071	锁止器	Latch	1		
4	480A 470748	滤 芯	Filter element	1		
5		转向油罐壳体	Oil container housing	1		



叶片泵 SEMI ROTARY PUMP ASSY

叶  
序

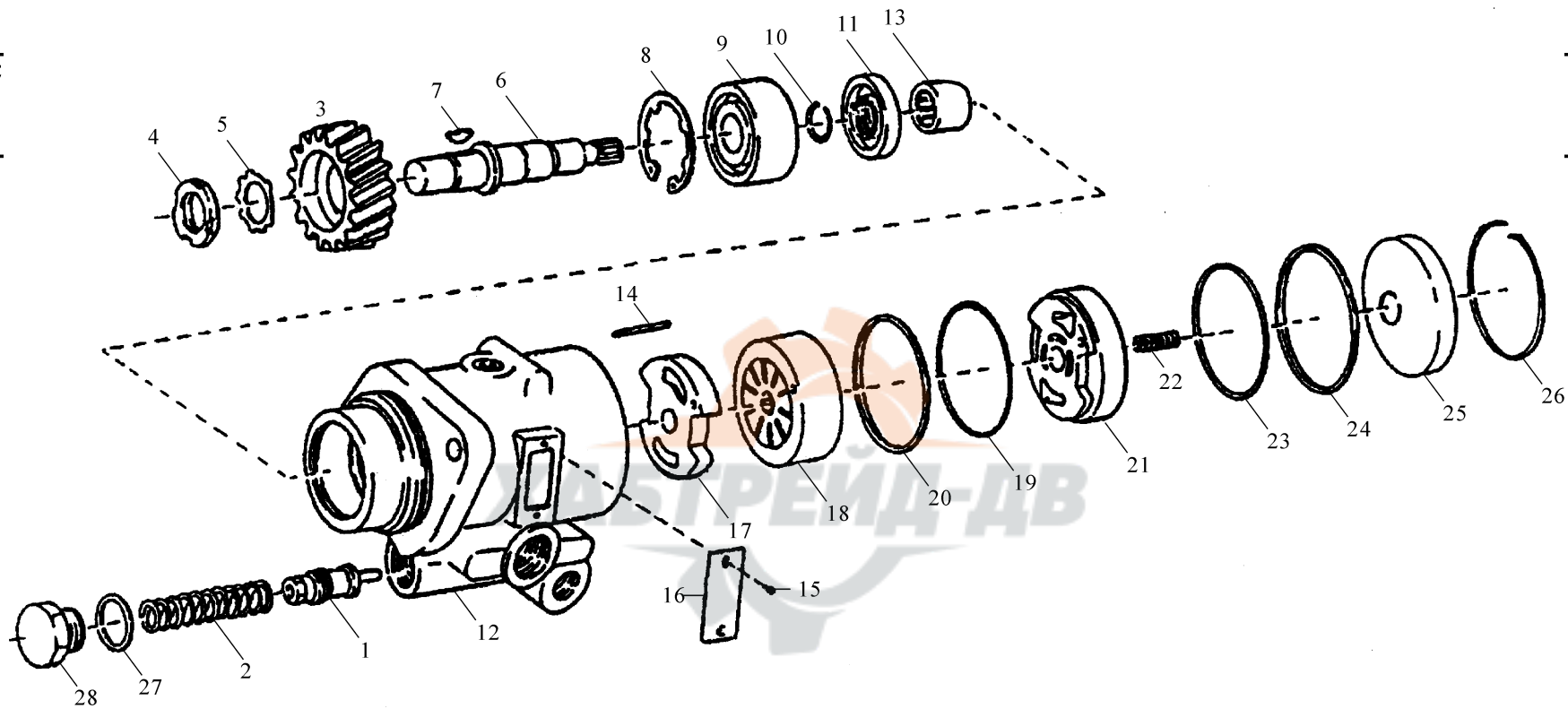

	DZ9100130037	叶片泵总成	Semi rotary pump assy	1		ZF7672955280(2—28)
	DZ9100130028	叶片泵总成	Semi rotary pump assy	1		420Ps
1	61500130716	流量控制活塞	Piston	1		7723036102
2	81500130760	压力弹簧	Spring	1		7673009102
3	61500130701	油泵驱动齿轮	Gear	1		M18×1.5
4	90003881318	圆螺母	Nut	1		
5	90003936422	锁片	Locking plate	1		7673014137
6	81500130821	驱动轴	Driving shaft	1		52×2
8	90003934739	内舌孔用弹性挡圈	Circlip	1		6304J
9	90003311472	滚珠轴承	Ball bearing	1		0770198091
11	81500130826	油封	Oil seal	1		0635303047
13	81500130822	滚针轴承	Needle bearing	1		7673041371
17	61200130759	进油端盖	Cover	1		7672860108
18	81500130824	转子副	Rotor set	1		0634316357
19	81500130827	O型密封圈	O-ring	1		7673041376
21	61200130760	出油端盖	Cover	1		7672036115
22	81500130825	压力弹簧	Spring	1		1634316358
23	81500130828	O型密封圈	O-ring	1		ZF7673037104
26	81500130768	弯头钢丝挡圈	Snap ring	1		
27	90003098026	密封垫片	Seal washer	1		7673633005(11,19,20,23,24)
	81500130820	密封组件	Seal set	1		

# 车架总成 (一) FRAME ASSY I

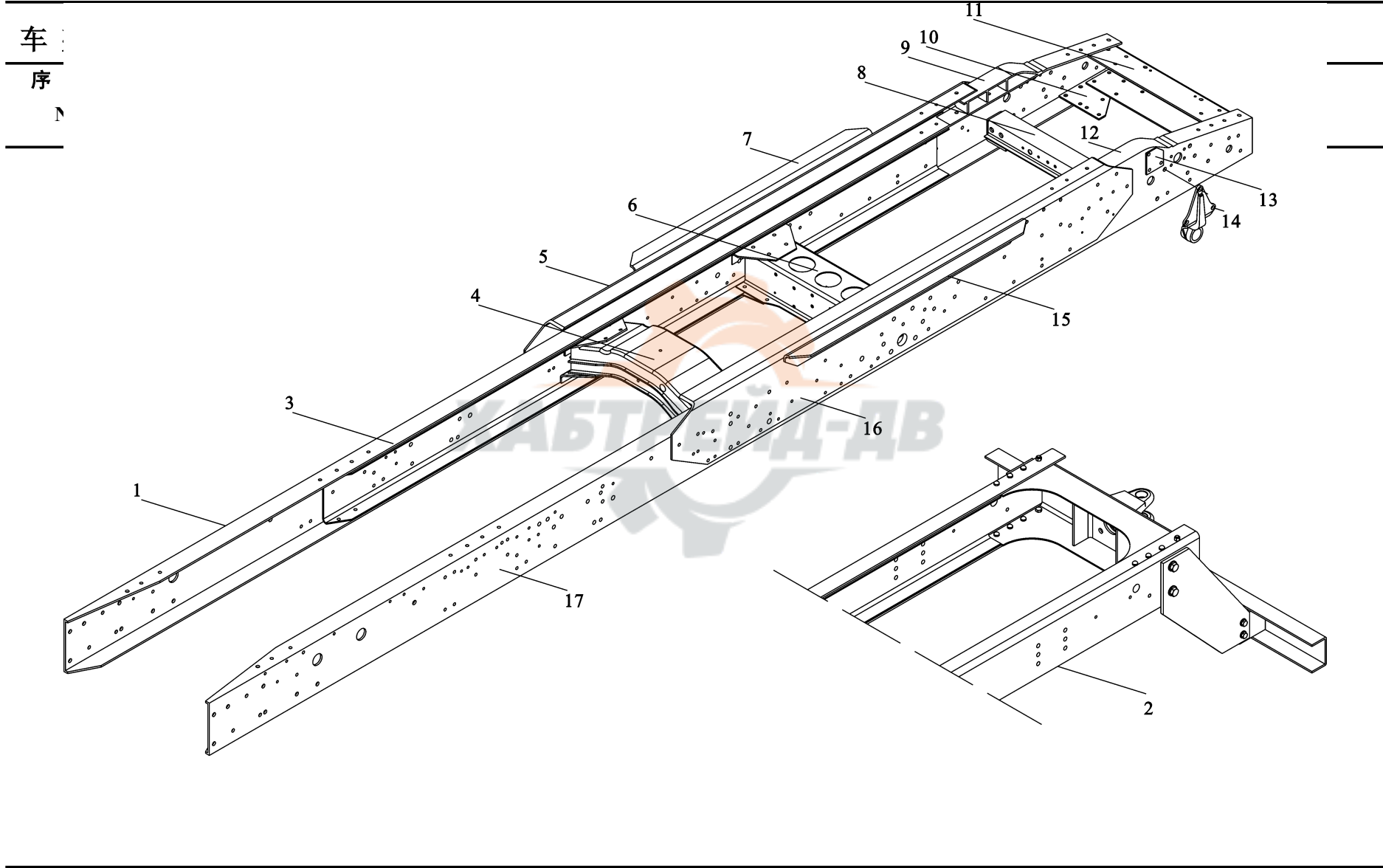



1	DZ9112510140	车架总成	Frame assy	1	4×2	牵引车 towing truck
	DZ9112510164	车架总成	Frame assy	1		
2	DZ9112510700	车架总成	Frame assy	1		牵引车 towing truck
3	DZ9112510142	右纵梁总成	Right carling assy	1		
4	DZ9100510150	横梁总成	Cross member	1		载货车 truck
5	DZ9112510058	右角支承板	Right support plate	1		
6	DZ9100510010	横梁总成	Cross member assy	1		
7	99100510357	右角形连接板	Right connection plate	1		
8	99100510098	横梁总成	Cross member assy	1		
9	DZ9100510158	右导板总成	Right guided plate assy	1		
10	880 510040	后横梁连接板	Rear cross member plate	2		
11		后横梁总成	Rear cross member	1		
12	AZ9112510342	左导板总成	Left guided plate	1		
13	DZ9100510157	连接板	Connection plate	2		
14	DZ9100510148	稳定杆托架	Stabilify rod bracket	2		
15	99100510008	左角形连接板	Left angle connection plate	1		
16	99100510356	左角支承板	Left support plate	1		
17	DZ9112510057	左纵梁总成	Left carling assy	1		
	DZ9112510141					

## 车架总成（二）FRAME ASSY II





车架

序号

NO

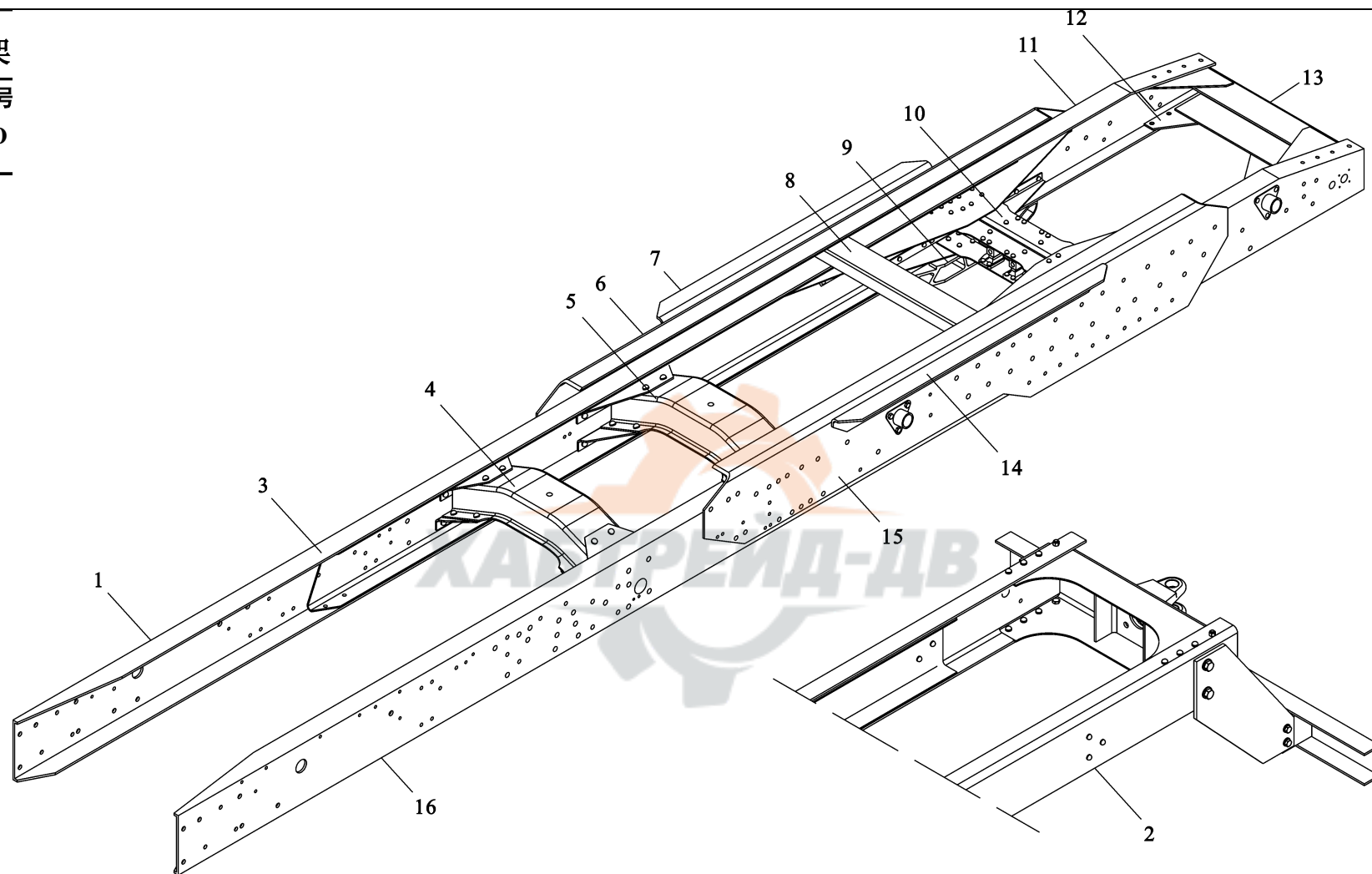

1	DZ9114512910	车架总成	Frame assy	1	6×4	□ 引□ towing truck
2	DZ9114512300	车架总成	Frame assy	1		□ □ □ truck
3	DZ9114512940	右纵梁总成	Right carling assy	1		
4	DZ9114512960	横梁总成	Cross member assy	1		
5	DZ9114512980	横梁总成	Cross member assy	1		
6	DZ9114512894	右支承板	Right support plate	1		
7	99114512876	右角板	Right angle plate	1		
8	99114512870	横梁总成	Cross member assy	1		
9	99114510015	中间支座	Connecting base	1		
10	99014512015	横梁总成	Cross member	1		
11	99014510226	支 架	Bracket	4		
12	880 510040	后横梁连接板	Rear cross member connection	2		
13	DZ9114512750	后横梁总成	plate	1		
14	99114512875	左角板	Rear cross member	1		
15	DZ9114512893	左支承板	Left angle plate	1		
16	DZ9114512893	左纵梁总成	Left support plate	1		
	DZ9114510260	左纵梁总成	Left carling assy	1		
			Left carling assy			右置车 to right

车 架 总 成 （ 三 ） FRAME ASSY III

车  
序

1

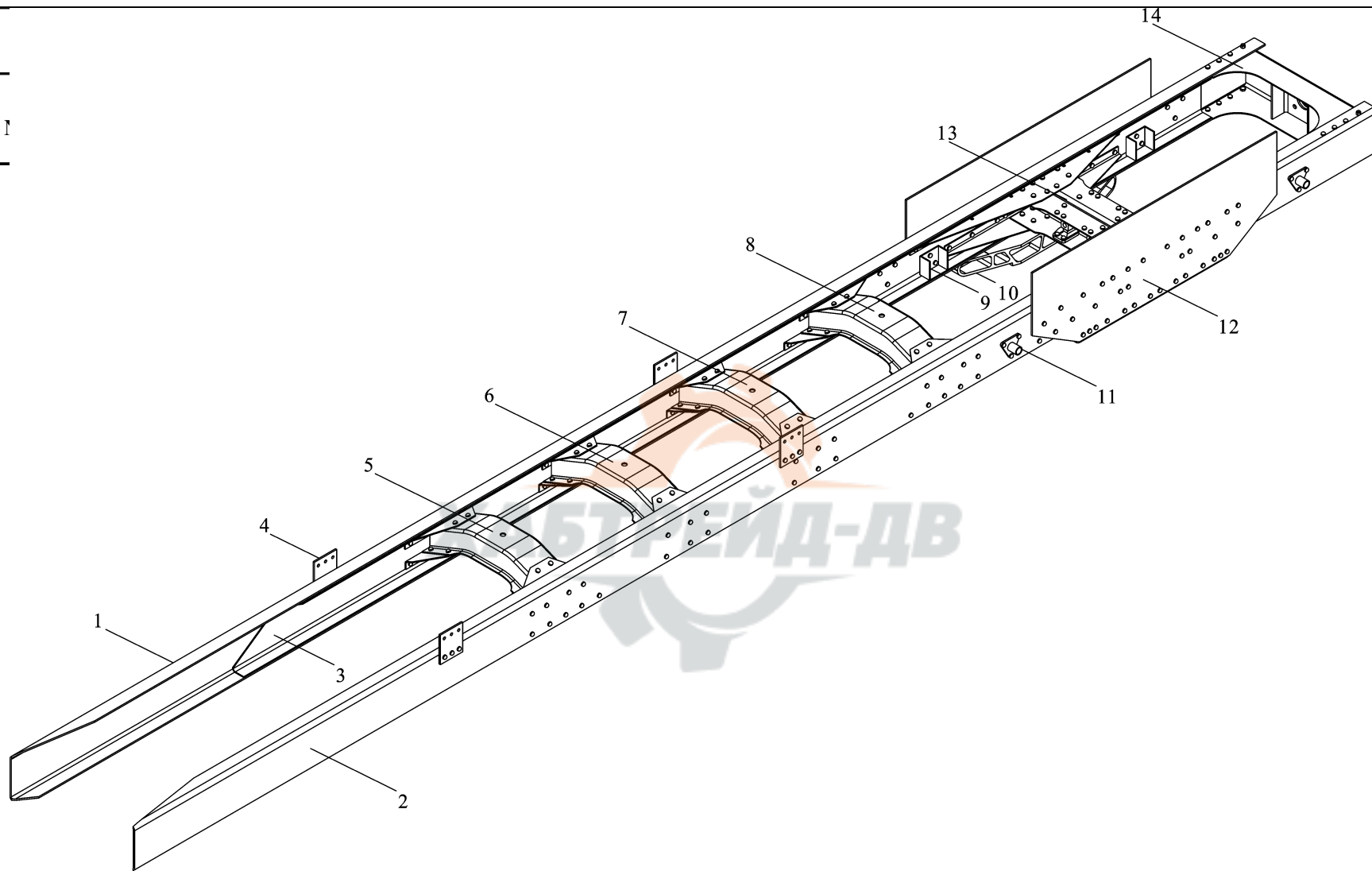

	DZ9118510060	车架总成	Frame assy	1	8×4	载货车 truck
	DZ9118510430	车架总成	Frame assy	1		
	DZ9114512910	车架总成	Frame assy	1		载货车 truck
1	DZ9118510062	右纵梁总成	Right carling assy	1		
2	DZ9118510061	左纵梁总成	Left carling assy	1		载货车 truck
3	3380-2801122	右加强板	Right strengthen plate	1		
	3380-2801121	左加强板	Left strengthen plate	1		
4	3380-2801111	连接板	Connecting plate	4		
5	3380-2801030	横梁总成	Cross member assy	1		
6	3380-2801040	横梁总成	Cross member assy	1		
7	DZ9118510080	横梁总成	Cross member assy	1		
8	3380-2801050	横梁总成	Cross member assy	1		
9	99014510226	支 架	Bracket	4		
10	3380-2801071	中间支座	Connecting base	2		
11	99014510038	限位绳支架	Position rope bracket	4		
12	3380-2801008	支承板	Support plate	2		
13	3380-2801060	横梁总成	Cross member assy	1		
14	3261-2801060	尾梁总成	Cauda cross member	1		

保 险 杠 及 联 接 支 架      BUMPER AND FRONT BRACKET

保 險

序 号

NO

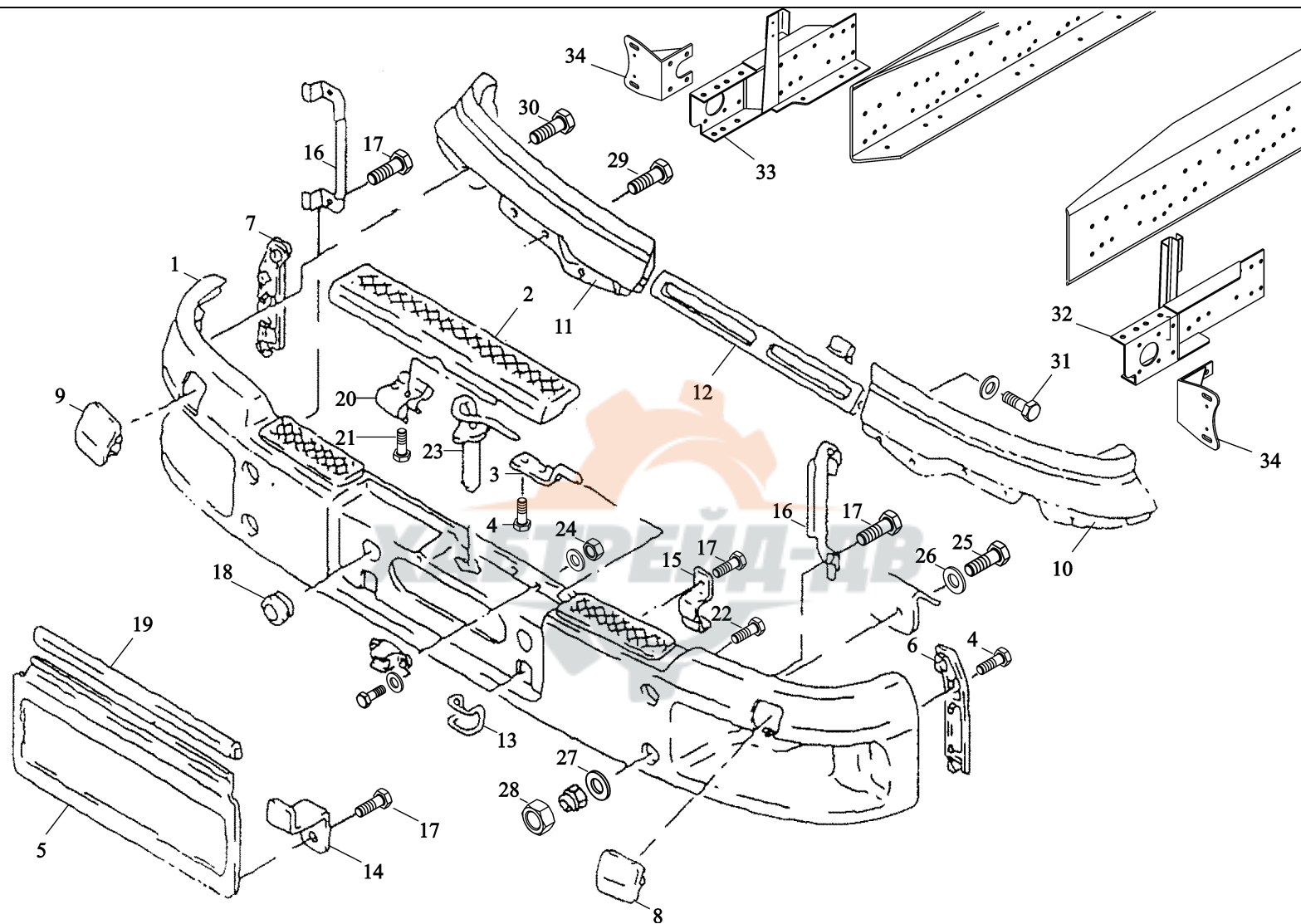



1	81.41610.4114	保险杠	Synthetic bumper assembly	1	
2	81.41610.0191	上装饰件	Flap upper	1	
3	81.41610.0154	卡子	Pin	2	
4	81.90470.0623	自攻螺栓	Screw	4	6.6×22-ST-T30-A3R
5	81.41610.0150	护面	Flap lower	1	
6	81.41610.0151	转向灯固定板(左)	Trim left	1	
7	81.41610.0152	转向灯固定板(右)	Trim right	1	
8	81.41610.0159	盖(左)	Cover left	1	
9	81.41610.0158	盖(右)	Cover right	1	
10	81.41610.0167	左挡板	Trim left wide	1	
11	81.41610.0166	右挡板	Trim right wide	1	
12	81.41610.0164	中间挡板	Trim center	1	
13	81.41610.0153	支架	Bracket	2	
14	81.97488.0075	双角铁	Double angle	2	
15	81.41610.0172	压板	Plate	2	
16	81.41610.0198	前照灯总成固定支架	Bracket	2	
17	81.90470.0623	自攻螺栓	Head screw	8	6.6×22-ST-T30-A3R
18	81.96001.0101	橡胶扣	Rubber grommet	2	22.0-30×8.5/45×18-GI-60
19	81.96121.0032	夹紧架	Clamping frame	2	
20	81.41610.0192	锁扣	Lock grommet	1	
21	81.90470.0619	六角头螺栓	Hex screw	2	PT-KA5×12-WN1412-10.9-A3C
22	81.90470.0623	螺钉	Screw	28	6.6×22-ST-T30-A3R
23	DZ9112930100	牵引销	Towing pin	1	
24	06.11069.0106	六角螺母	Hexagon nut	2	M6-8-A2R
25	06.01733.6313	六角螺栓	Hex bolt	4	M12×1.5×40-8.8-MAN183-B1

保险杠及联接支架 BUMPER AND FRONT BRACKET

保 險

序 号

NO

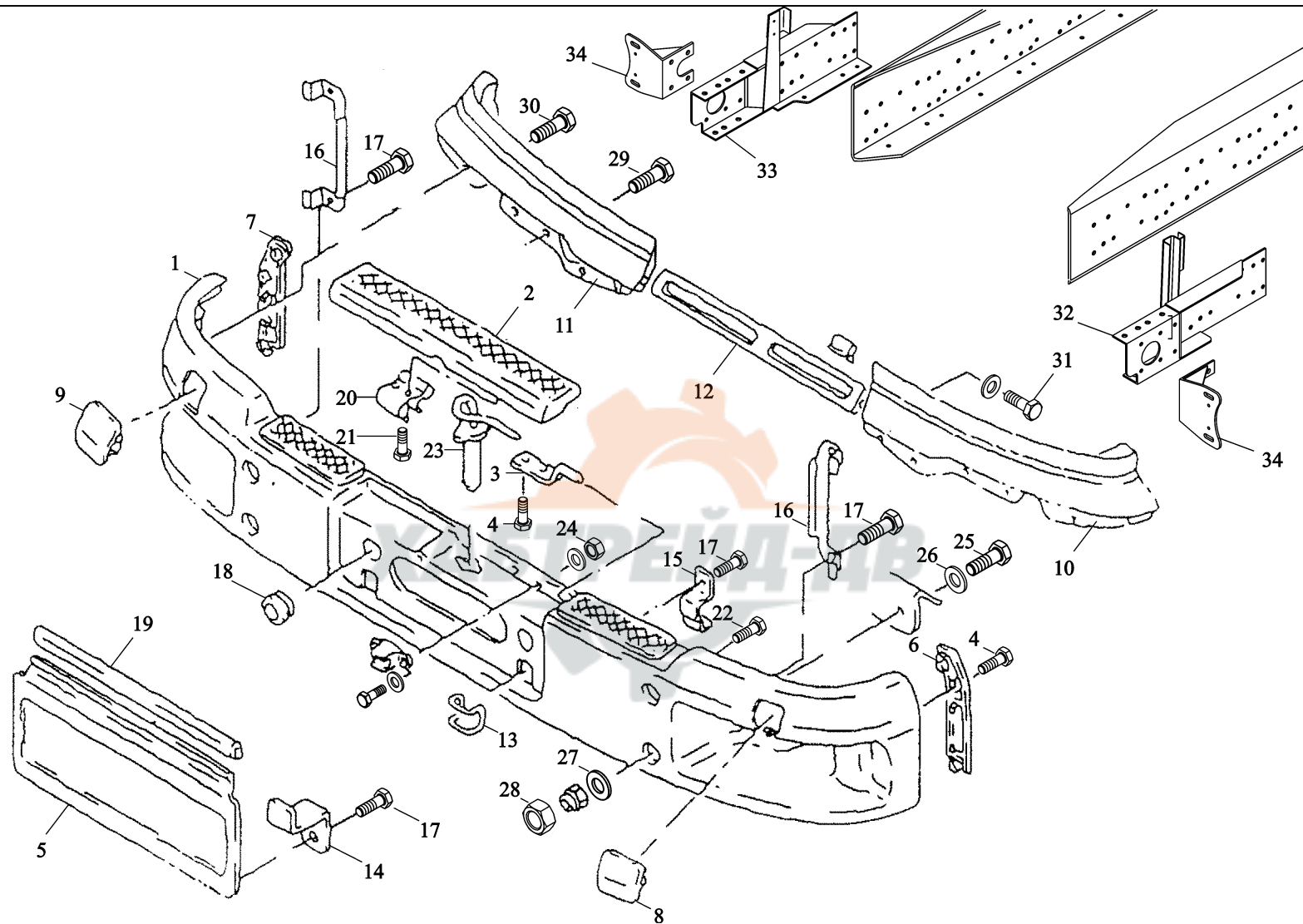

26	06.15030.0815	垫 圈	Washer	4		13×20×2-140HV-MAN183-B1
27	81.90712.0881	垫 圈	Washer	4		
28	81.96002.0425	盖	Cap	4		
29	81.90470.0623	自攻螺栓	Screw	10		6.6×22-ST-T30-A3R
30	81.90470.0624	六角头螺栓	Screw	2		6.6×40-ST-T30-A3R
31	81.90470.0621	自攻螺钉	Screw	2		PT-KA5×20-WN1411-10.9-A3R
32	DZ9112930030	左托架总成	Left bracket assy	1		
33	DZ9112930040	右托架总成	Right bracket assy	1		
34	81.41601.5044	上保险杠固定座	Position base	2		

副 保 险 杠 及 联 接 支 架      AUXILIARY BUMPER AND FRONT BRACKET

副保险杆

序号  
NO

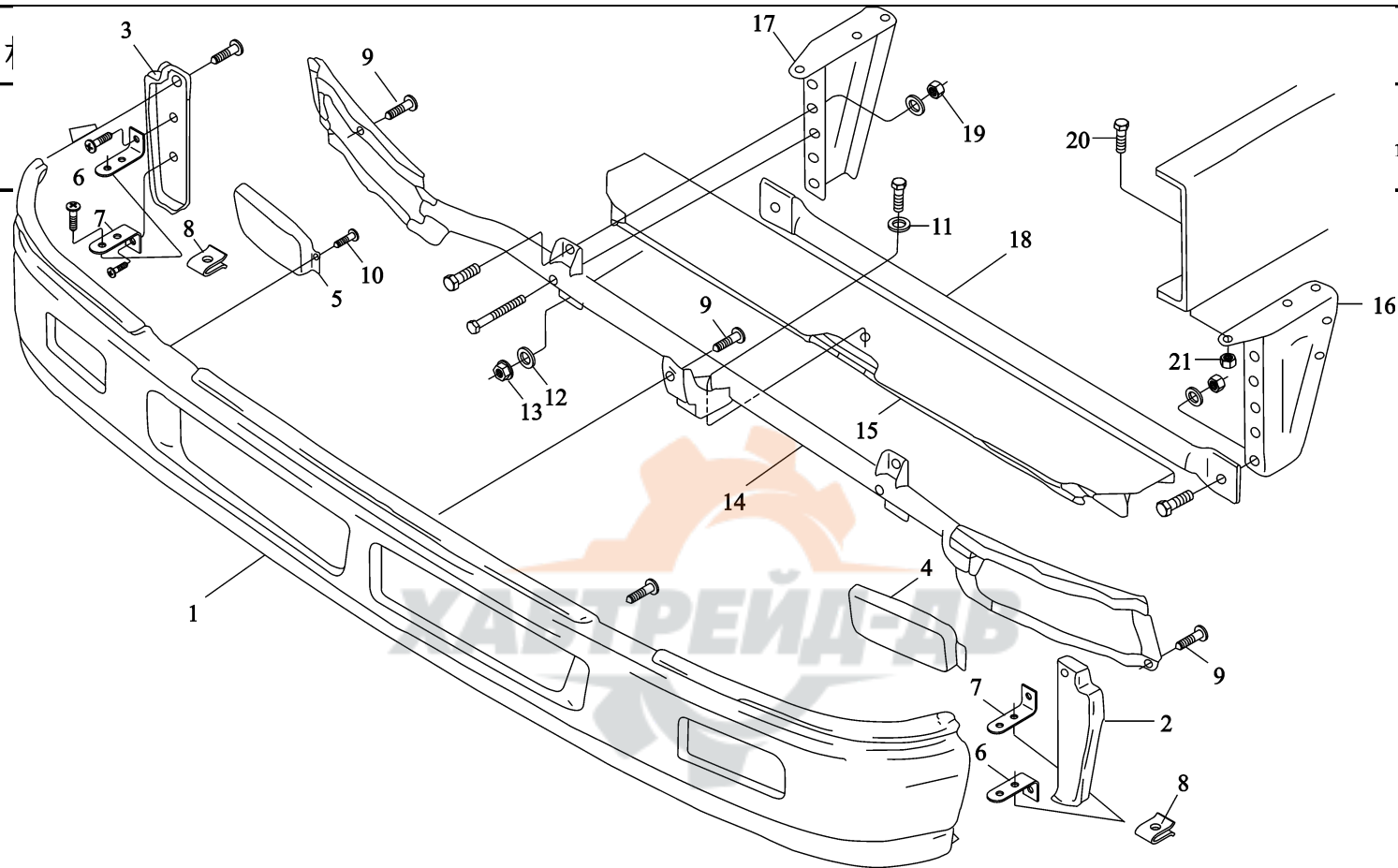

注  
mark

1	81.41613.0074	副保险杠总成	Auxiliary bumper assy	1	高位保险杠 (high position)
	81.41613.0071	副保险杠总成	Auxiliary bumper assy	1	
2	81.41613.0069	前雾灯盲孔盖 (左)	Trim left	1	低位保险杠 (lower position)
3	81.41613.0066	前雾灯盲孔盖 (右)	Trim right	1	
4	81.41613.0081	左端板	Plane board left		
5	81.41613.0080	右端板	Plane board right		低位保险杠 (lower position)
6	81.41613.0077	下支架	Bracket lower	2	
7	81.41613.0076	上支架	Bracket upper	2	低位保险杠 (lower position)
8	8141613.5031	角 板	Speed nut	12	
9	81.90470.0618	六角头螺栓	Grooved raised head	18	高位保险杠 (high position)
10	81.90470.0619	六角头螺栓	coll.screw	8	
11	06.15190.0309	垫 圈	Grooved oval head screw	1	高位保险杠 (high position)
12	06.15190.0311	垫 圈	Washer	2	
13	06.11240.0406	六角锁紧螺母	Washer	2	ST4.8-5-MAN183-B1
14	81.41613.5035	大灯支架	Hex lock nut	1	PT-KA6×20-WN1411-10.9-A3R
15	81.41615.5061	脚踏板	Airdam mounting assembly	1	PT-KA5×12-WN1412-10.9-A3C
16	DZ9112930252	左下支架	Foothold assembly	1	8.4×24×2-140HV-MAN183-B1
17	DZ9112930253	右下支架	Bracket left	1	13×37×3-140HV-MAN183-B1
18	81.41653.0004	撑 杆	Bracket right	1	BM10-8-MAN183-B1
19	06.11251.2001	六角锁紧螺母	Protective tube	4	
20	06.02813.4911	六角锁紧螺钉	Hex lock nut	6	
21	06.11251.2005	六角锁紧螺母	Hex lock screw	6	
			Hex lock nut		M10-10-MAN183-B1

左、右翼子板支架 LEFT/RIGHT FENDER BRACKET

左、

序号  
NO

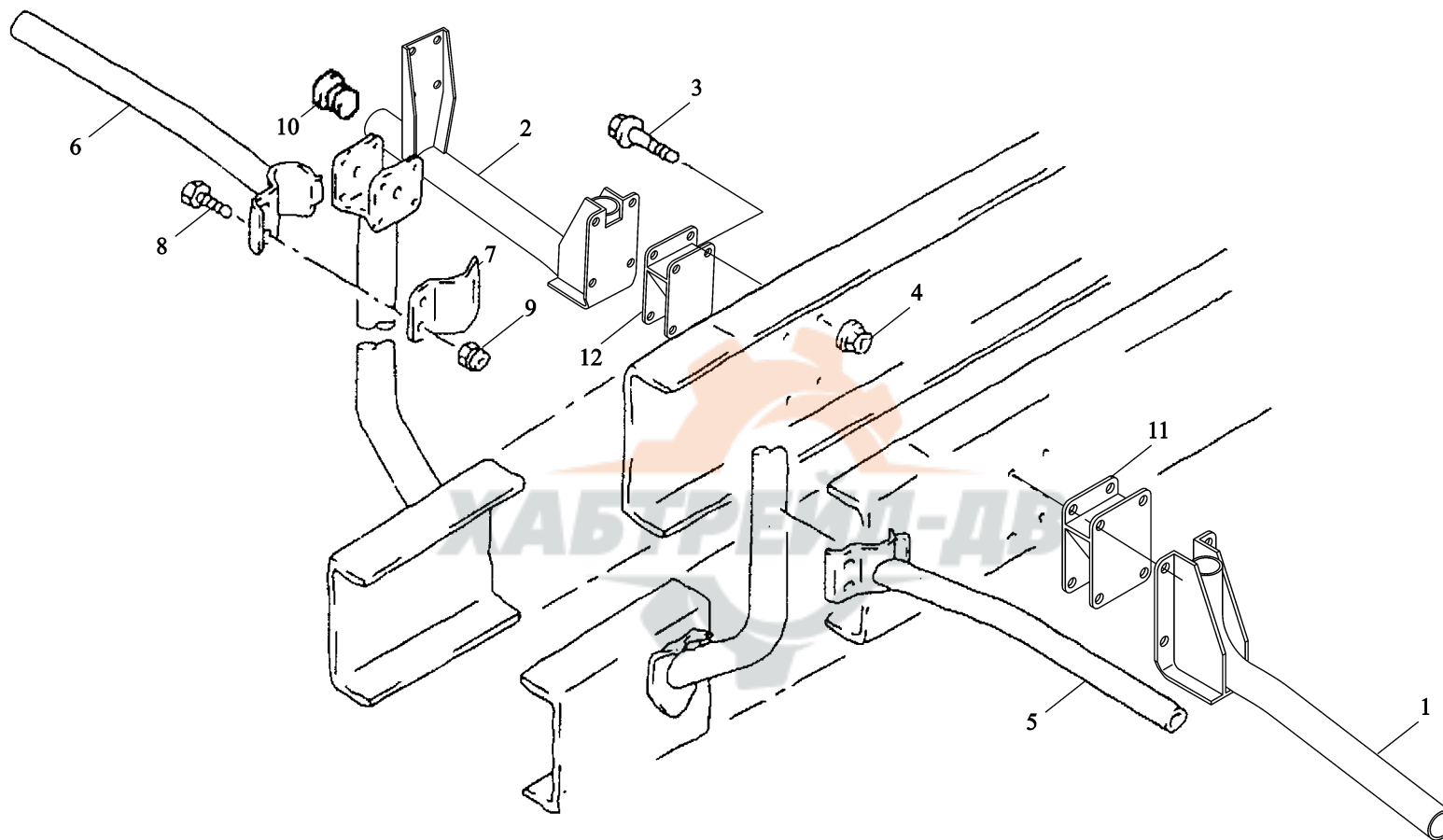

1	81.61243.5265	左后翼子板支架总成	Bracket assembly left	1	SX4195NW351	
	DZ1640230020	左后翼子板支架总成	Bracket assembly left	1		
	DZ1640230030	左后翼子板支架总成	Bracket assembly left	1	SX4195JV351	
2	81.61243.5267	右后翼子板支架总成	Bracket assembly right	1		
	DZ1640230026	右后翼子板支架总成	Bracket assembly right	1		
	DZ1640230040	右后翼子板支架总成	Bracket assembly right	1	SX4195JV351	
3	Q150B1430	六角螺栓	Hex lock screw	16		M14×1.5×40-10.9-MAN183-B1
4	Q33414	六角锁紧螺母	Hex lock screw	16		M14×1.5-10-MAN183-B1
5	81.61243.5234	前支架	Bracket assembly left	1		
6	81.61243.5236	前支架	Bracket assembly right	1		
7	81.61243.0086	夹片	Mounting clamp	2		
8	Q150B1030	六角螺栓	Hex bolt	4		M10×30-8.8-MAN183-B1
9	Q33410	六角锁紧螺母	Hex lock nut	4		BM10-8-MAN183-B1
10	81.96002.0416	盲盖	Plug	4		
11	DZ1640230060	左翼子板支座总成	Bracket base left	1		
12	DZ1640230050	右翼子板支座总成	Bracket base right	1		

踏板支架 FOOT PANEL BRACKET

# 踏板支

序号
NO

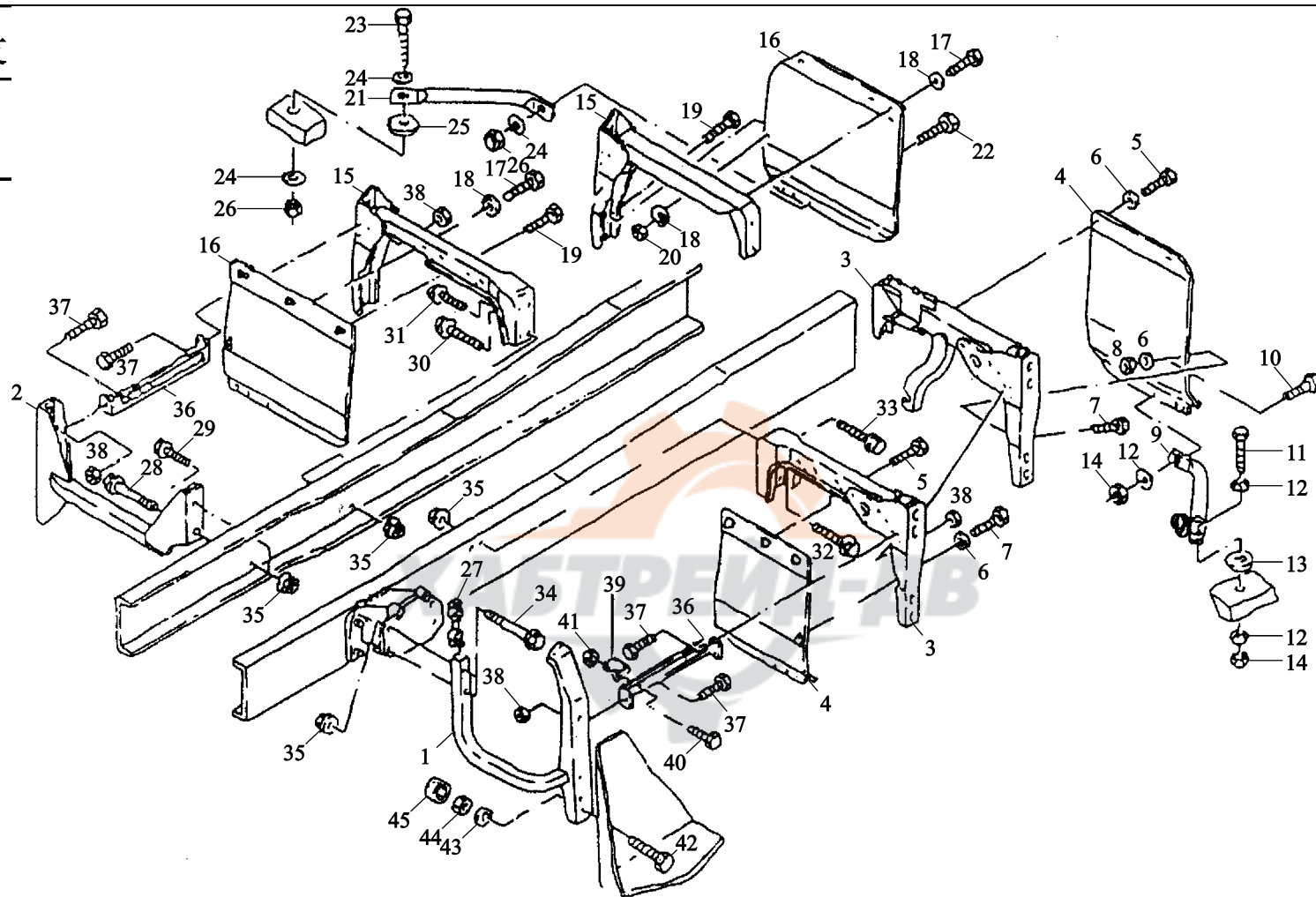

E
rk



1	81.41890.5059	左前踏板支架总成	Bracket assembly left front	1		
	DZ1642240140	左前踏板支架总成	Bracket assembly left front			
	DZ1640240050	左前踏板支架总成	Bracket assembly left front	1		用于右置车
2	81.41890.5062	右前踏板支架总成	Bracket assembly right front	1		
	DZ1640240020	右前踏板支架总成	Bracket assembly right front			
	DZ1642240120	右前踏板支架总成	Bracket assembly right front			
3	81.41890.5119	左后踏板支架总成	Bracket assembly left rear	1		
	DZ1640240029	左后踏板支架总成	Bracket assembly left rear	1		用于右置车
	DZ1640240031	左后踏板支架总成	Bracket assembly left rear			
	DZ1640240040	左后踏板支架总成	Bracket assembly left rear	1		
	DZ1642240150	左后踏板支架总成	Bracket assembly left rear			
4	DZ1642240009	左后盖板	Cover plate left rear	1		
	81.41890.0011	左后盖板	Cover plate left rear			
	DZ1642240011	左后盖板	Cover plate left rear			
	DZ1642240013	左后盖板	Cover plate left rear			
5	06.01303.2910	六角螺栓	Hex bolt	5		M6×12SK-8.8-MAN183-A2C
6	06.15013.0409	垫 片	Washer	2		A6.4×12×1.6-200HV- MAN183-B1
7	06.01283.4911	六角螺栓	Hex bolt	1		M6×16-8.8-MAN183-B1
8	06.11240.0303	六角锁紧螺母	Hex lock nut	1		AM6-8-MAN183-B1
9	81.41890.0051	左支柱	Support left	1		
10	06.01289.0262	六角螺栓	Hex bolt	1		M8×18-8.8-MAN183-A2R
11	06.01289.0264	六角螺栓	Hex bolt	1		M8×28-8.8-MAN183-A2R
12	06.15019.0084	垫 片	Washer	4		A8.4×16×1.6-200HV-MAN183-B4
13	06.15190.0409	垫 片	Washer	1		8.4×24×2-140HV-MAN183-B4

# 踏板支架 FOOT PANEL BRACKET

踏板支

序号
NO

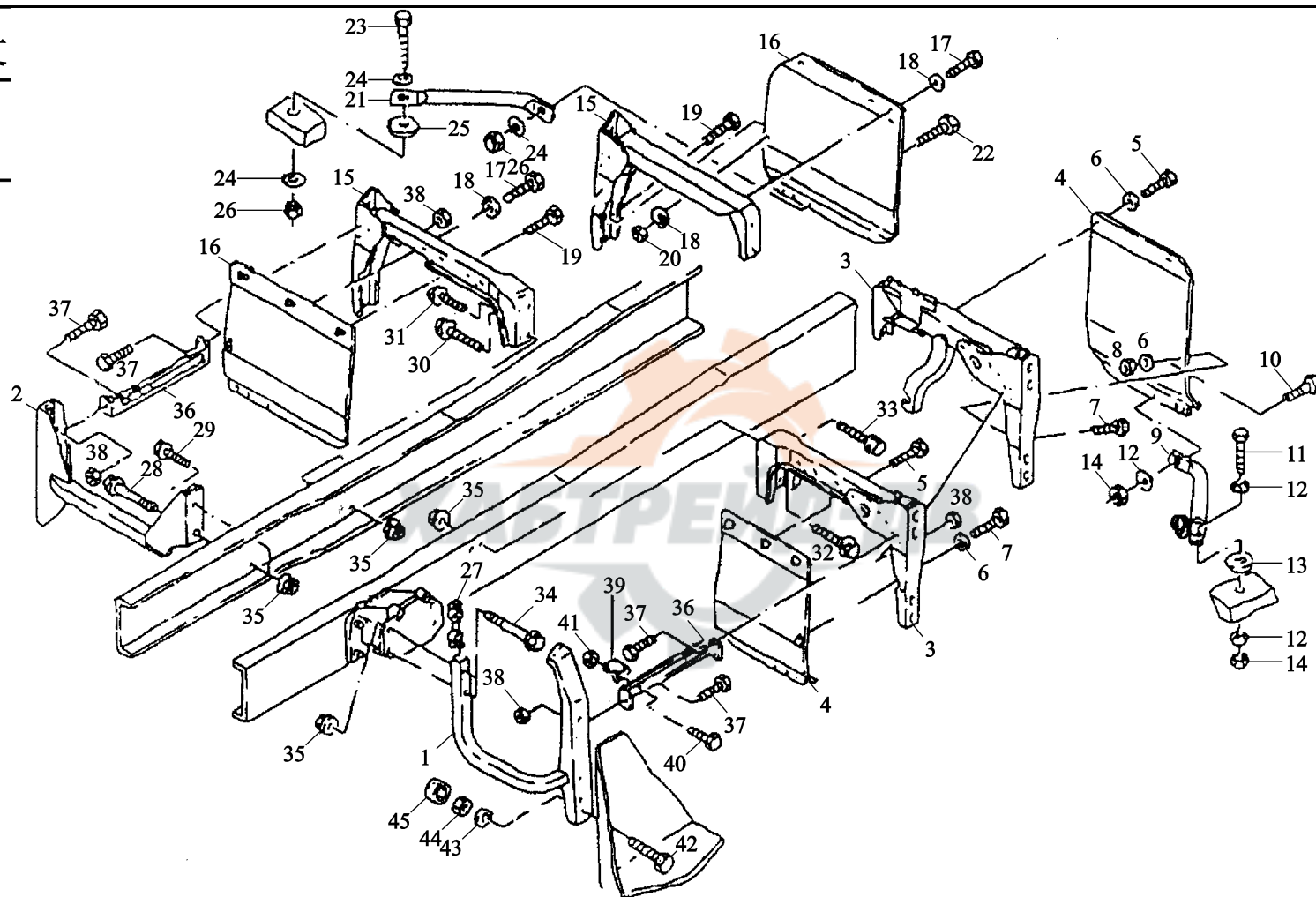

主  
rk

14	06.11069.0158	六角螺母	Hexagon nut	2		M8-8-MAN183-B4
15	81.41890.5068	右后踏板支架总成	Bracket assembly right rear	1		用于右置车
	DZ1640240030	右后踏板支架总成	Bracket assembly right rear			
	DZ1640240032	右后踏板支架总成	Bracket assembly right rear			
	81.41890.5080	右后踏板支架总成	Bracket assembly right rear			
	DZ1643240030	右后踏板支架总成	Bracket assembly right rear			
16	81.41890.0008	右后盖板总成	Cover plate right rear	1		油田专用车
	DZ1642240010	右后盖板总成	Cover plate right rear			油田专用车
	DZ1642240014	右后盖板总成	Cover plate right rear			
17	06.01303.2910	六角螺栓	Hex bolt	3		M6×12SK-8.8-MAN183-A2C
18	06.15013.0409	垫 片	Washer	5		A6.4×12×1.6-200HV- MAN183-B1
19	06.01283.4911	六角螺栓	Hex bolt	2		M6×16-8.8-MAN183-B1
20	06.11240.0303	六角螺栓	Hex lock nut	2		AM16-8-MAN183-B1
21	81.41890.0050	右支柱	Support right	1		
22	06.01289.0262	六角螺栓	Hex bolt	1		M8×188.8-MAN183-A2R
23	06.01289.0264	六角螺栓	Hex bolt	1		M8×28-8.8-MAN183-A2R
24	06.15019.0084	垫 片	Washer	4		A8.4×16×1.6-200HV- MAN183-B4
25	06.15190.0409	垫 片	Washer	1		8.4×24×2-140HV-MAN183-B4
26	06.11069.0158	六角螺母	Hexagon nut	2		M8-8-MAN183-B4
27	81.41820.5061	衬垫总成	Packing assembly	1		
28	06.02815.8934	六角锁紧螺钉	Hex lock screw	1		M14×1.5×95-10.9-MAN183-A3C
29	06.02813.4914	六角锁紧螺钉	Hex lock screw	1		M14×1.5×45-10.9-MAN183-B1
30	06.02813.4913	六角锁紧螺钉	Hex lock screw	2		M14×1.5×40-10.9-MAN183-B1

## 踏 板 支 架      FOOT PANEL BRACKET



踏板支

序号
NO

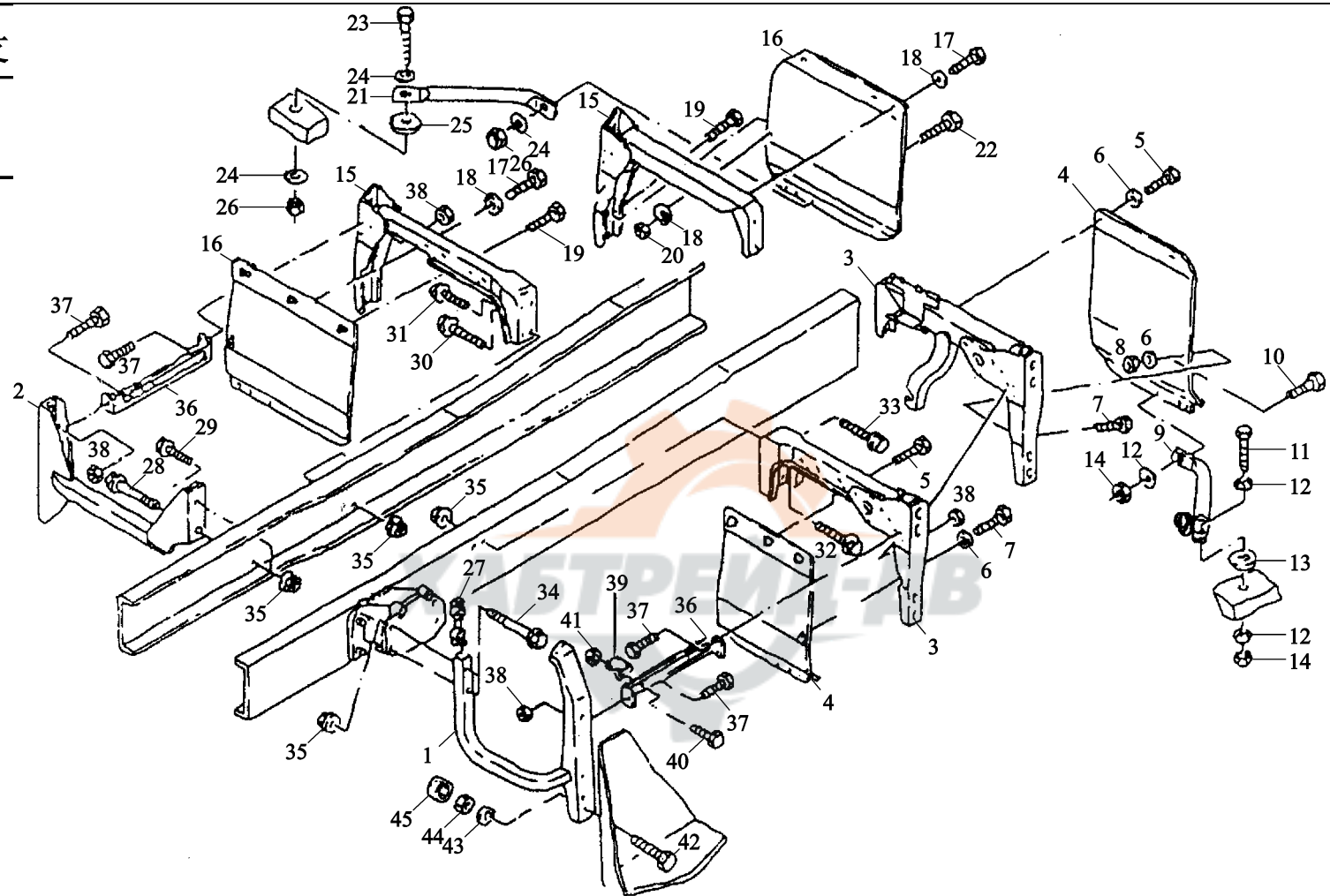

主
rk

31	06.02813.4911	六角锁紧螺钉	Hex lock screw	2		M14×1.5×30-10.9-MAN183-B1
32	06.02813.4913	六角锁紧螺钉	Hex lock screw	2		M14×1.5×40-10.9-MAN183-B1
33	06.02813.4911	六角锁紧螺钉	Hex lock screw	2		M14×1.5×30-10.9-MAN183-B1
34	06.02813.4918	六角锁紧螺钉	Hex lock screw	2		M14×1.5×65-10.9-MAN183-B1
35	06.11251.2005	六角锁紧螺钉	Hex lock nut	8		M14×1.5-10-MAN183-B1
36	81.41890.0044	支 座	Support	2		
37	06.01283.5112	六角螺栓	Hex bolt	6		M8×18-8.8-MAN183-B1
38	06.11251.2018	六角锁紧螺母	Hex lock nut	6		M8-10-MAN183-B1
39	81.27421.0151	压力传感器	Sensor	2		
40	06.01283.5112	六角螺栓	Hex bolt	2		M8×18-8.8-MAN183-B1
41	06.11240.0404	六角锁紧螺母	Hex lock nut	2		BM8-8-MAN183-B1
	06.11251.2018	六角锁紧螺母	Hex lock nut	2		M8-10-MAN183-B1
42	06.01283.5215	六角螺母	Hex bolt	8		M10×25-8.8-MAN183-B1
43	06.15199.0016	垫 圈	Washer	8		10.5×30×2.5-140HV-a2-a3R
44	06.11240.0406	六角锁紧螺母	Hex lock nut	8		BM10-8-MAN183-B1
45	88.96002.0027	盖	Cap	8		

后翼子板（一） REAR FENDER I

后  
序

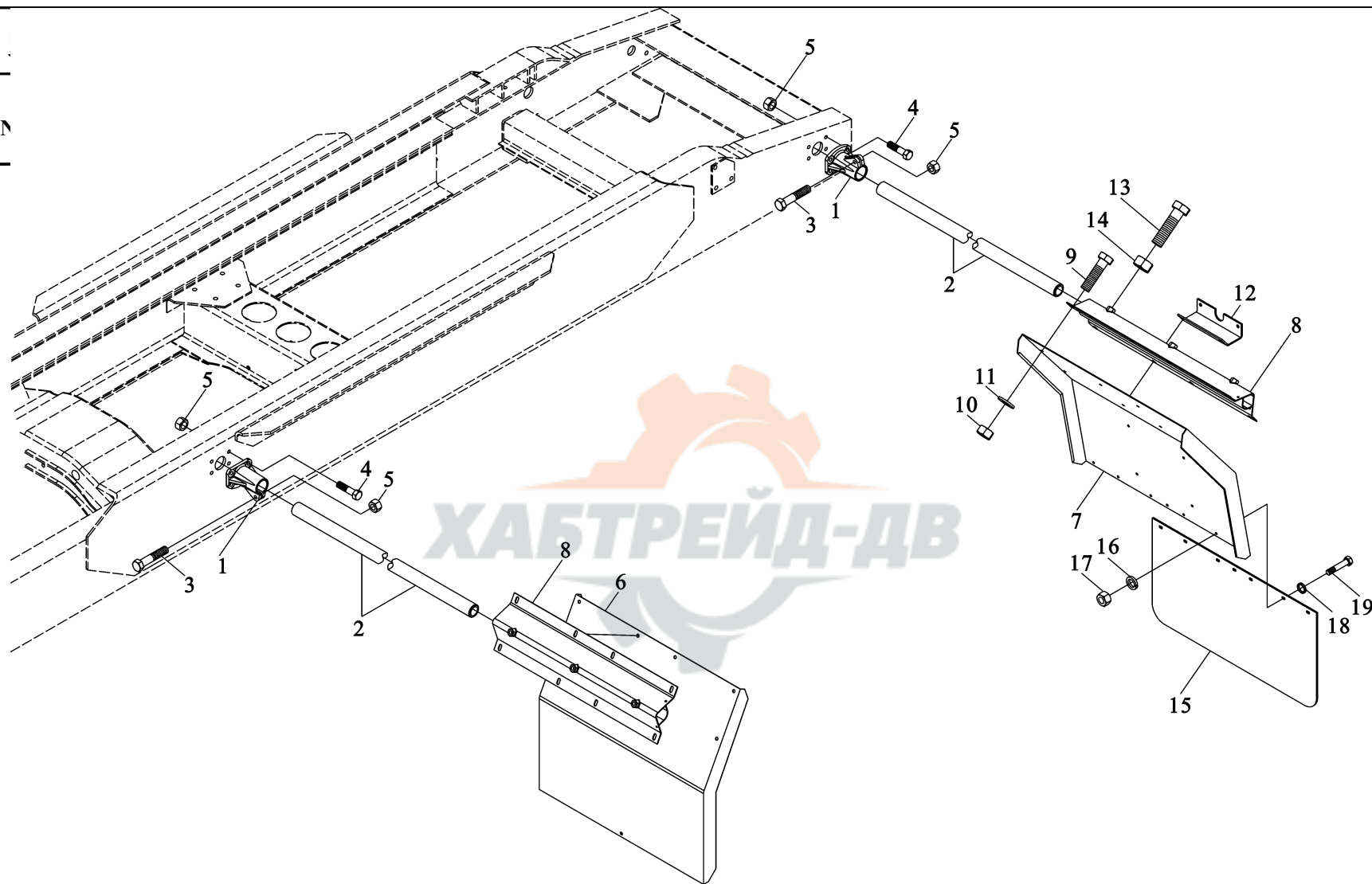

1	99014950008	固定托架	Bracket	4	
2	99112950070	管 梁	Carrier	2	
3	90003800529	六角头螺栓	Hex screw	12	Q150B1040
4	90008302532	六角头螺栓	Hex screw	16	Q150B1035
5	90003888452	Ⅱ型全金属六角锁紧螺	Locking nut	12	Q332210
6	99112950066	母	Front fender	2	
7	AZ9112950123	前弓形翼子板	Rear fender	2	
8	99114950070	后弓形翼子板	Plate	4	
9	90003802419	加强板总成	Hex screw	28	Q150B0820
10	90003888451	六角头螺栓	Locking nut	28	Q33208
11	90003936103	Ⅱ型全金属六角锁紧螺	Washer	32	Q40208
12	AZ9112950125	母	Light holder	2	
13	90003802527	大垫圈	Hex screw	12	Q150B1030
14	90003871305	灯 架	Nut	12	Q340B10
15	AZ9100950027	六角头螺栓	Mudguard	2	
16	90003931082	I型六角螺母	Spring washer	12	Q40506
17	90003871232	挡泥板	Hex nut	12	Q340B06
18	90003936101	重型弹簧垫圈	Washer	12	Q40206
19	90003802331	I型六角螺母 大垫圈 六角头螺栓	Hex screw	12	Q150B0620

后翼子板（二） REAR FENDER II



后  
序

1

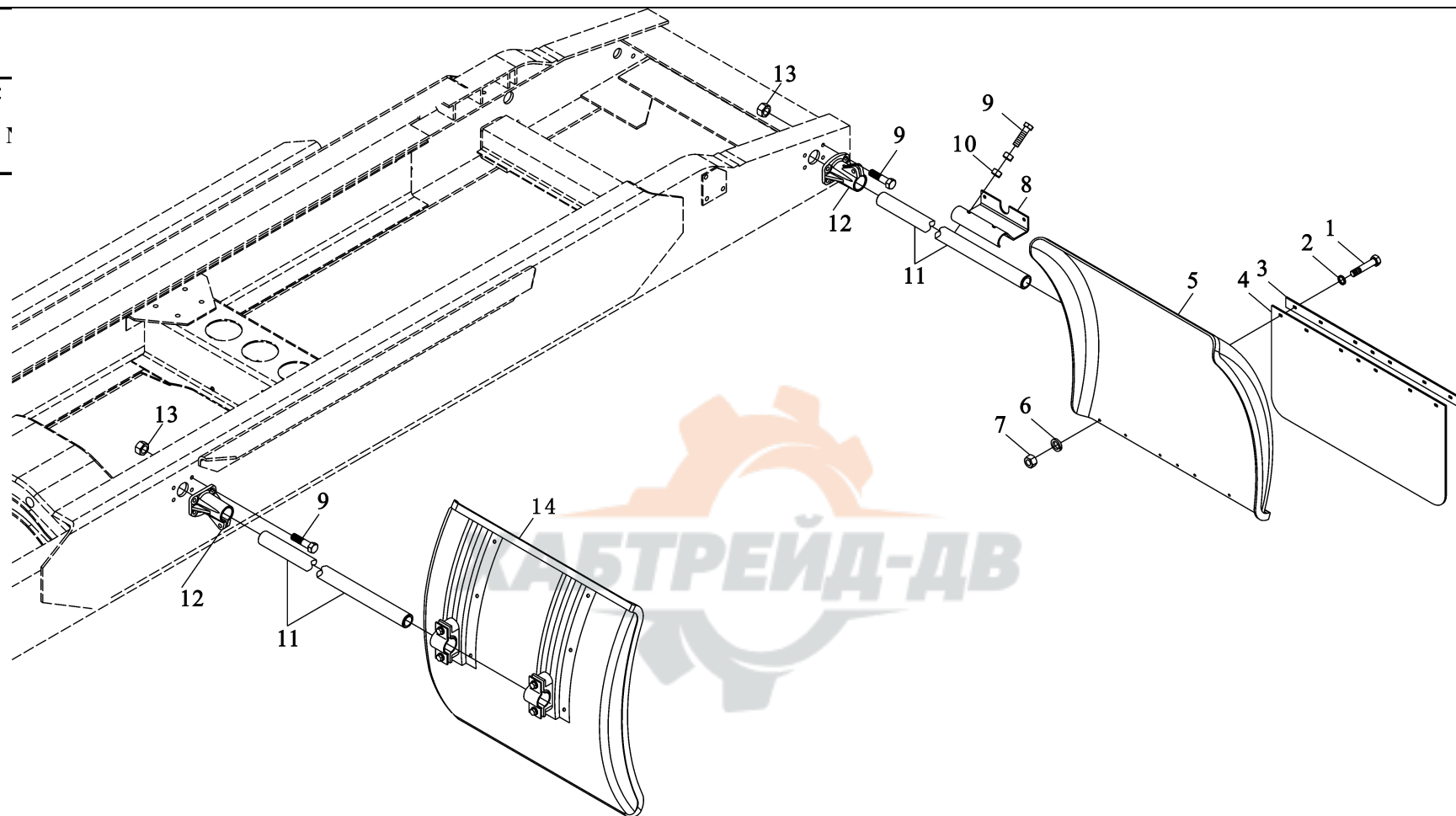

1	Q150B0620	六角头螺栓	Hex screw	10		
2	Q40206	大垫圈	Washer	10		
3	DZ9112952068	挡泥板压条	Plate	2		
4	DZ9112952069	挡泥板	Mudguard	2		
5	DZ9112952065	后翼子板	Rear fender	2		
6	Q40506	重型弹簧垫圈	Spring washer	10		
7	Q340B06	I 型六角螺母	Hex nut	10		
8	DZ9112950110	尾灯支架总成	Tail light carrier	1		
	DZ9112950120	尾灯支架总成 (右)	Tail light carrier (right)	1		
9	Q150B1040	六角头螺栓	Hex screw	24		
10	Q340B10	I 型六角螺母	Hex nut	4		
11	DZ9112952070	管梁总成	Carrier assy	2		
12	99014950008	固定托架	Barcket	4		
13	Q332210	II 型全金属六角锁紧螺	Locking nut	20		
14	DZ9112952066	母 前翼子板	Front frnder	2		

后保险杠及牵引钩 REAR BUMPER AND TOWING HOOK

# 后保险杠及牵引

序号 NO	件号 Part.No
----------	---------------

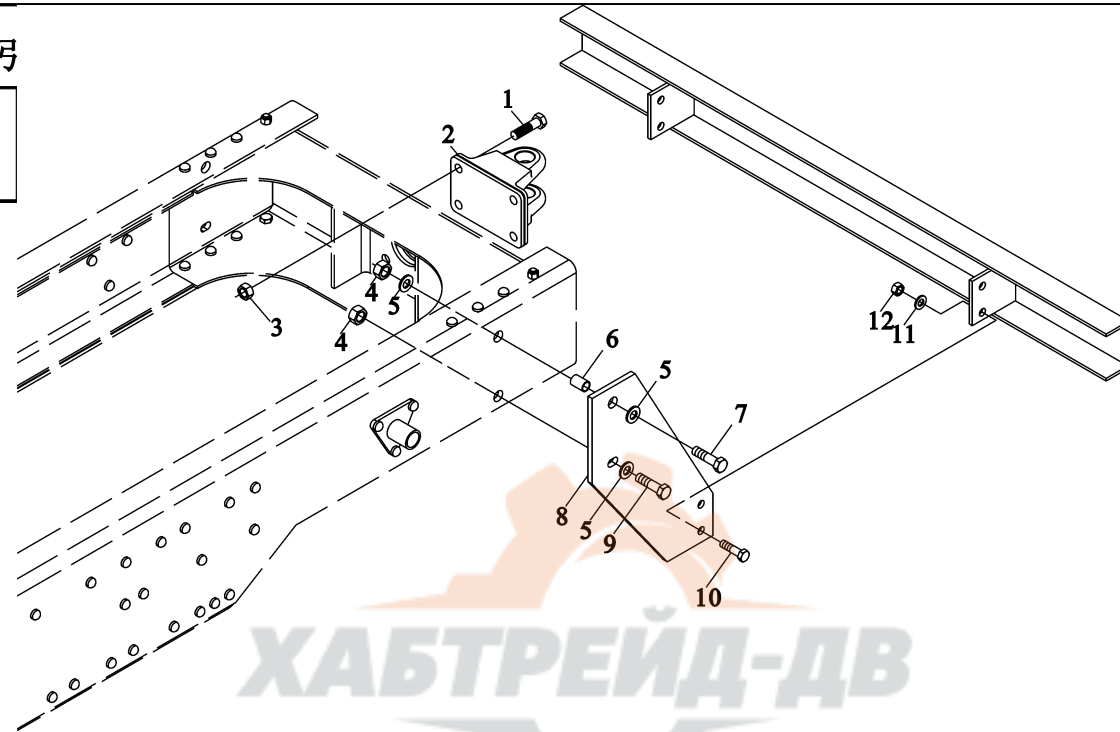

备注 Remark
--------------

1	Q151B1665	六角头螺栓	Hex screw	4		
2	DZ9100930010	牵引钩	Towing hook	1		
3	90003888459	自锁螺母	Locking nut	4		
4	Q33216	II型全金属六角锁紧螺	Locking nut	4		
5	190003937830	母	Washer	6		
6	DZ9114930016	垫 圈	Bush	2		
7	Q150B1655	套 筒	Hex screw	2		
8	DZ9114930031	六角头螺栓	Support plate	2		
9	Q150B1650	支承板	Hex screw	2		
10	Q150B1435	六角头螺栓	Hex screw	4		
11	Q40114	六角头螺栓	Flat washer	8		
12	Q33214	平垫圈	Locking nut	4		
		II型全金属六角锁紧螺 母				

尾灯支架 TAIL LIGHTS BRACKET

尾灯

序号

NO

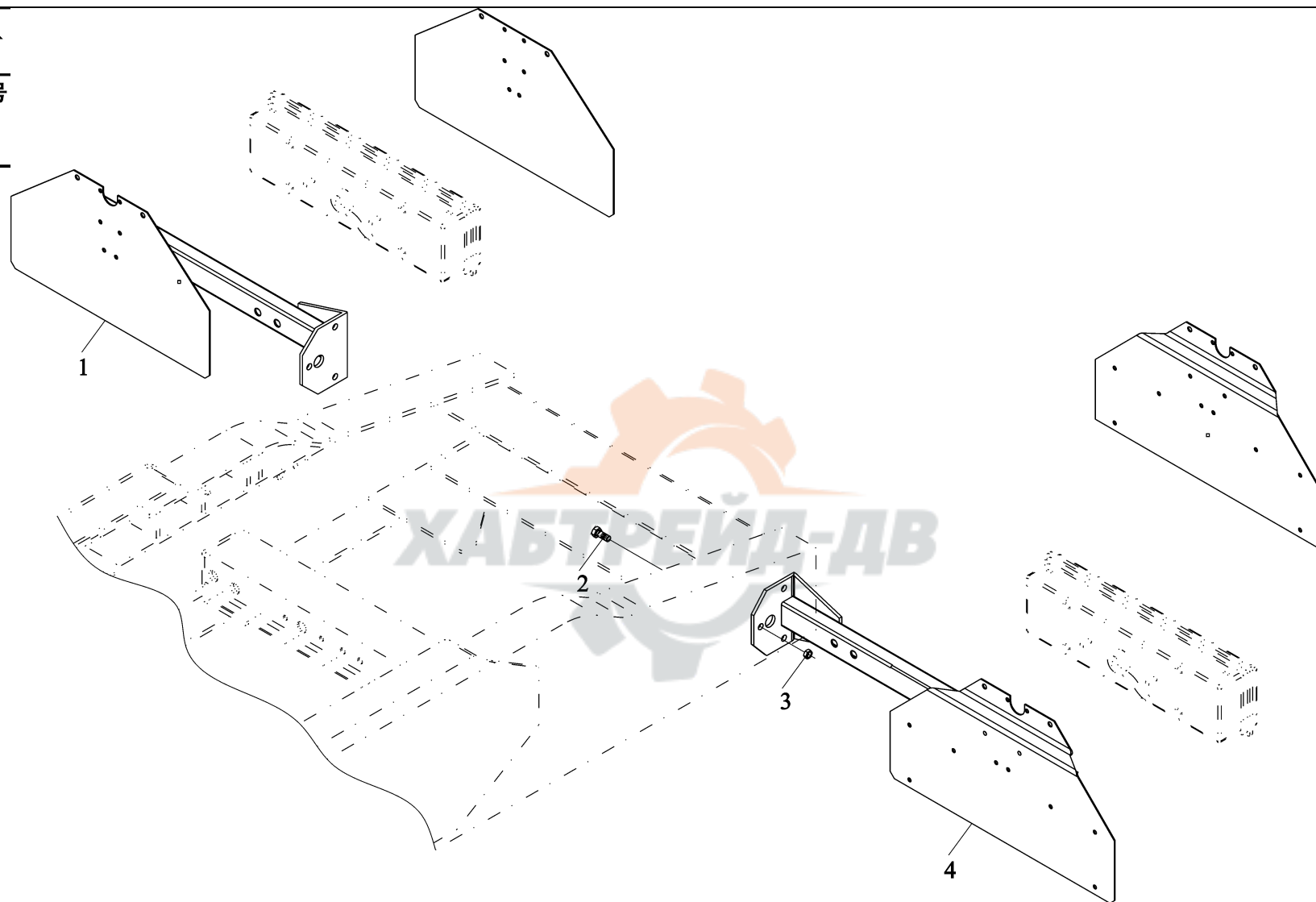

1	AZ9100940003	尾灯支架总成	Tail light carrier	1		
2	Q150B1035	六角头螺栓	Hex screw	6		
3	Q33410	I 型全金属六角锁紧螺	Locking nut	6		
4	AZ9100940025	母 标记支架总成	Support	1		

侧护板及操作平台      SIDE PROTECT PLATE AND OPERATING FLAT ROOF

侧  
序

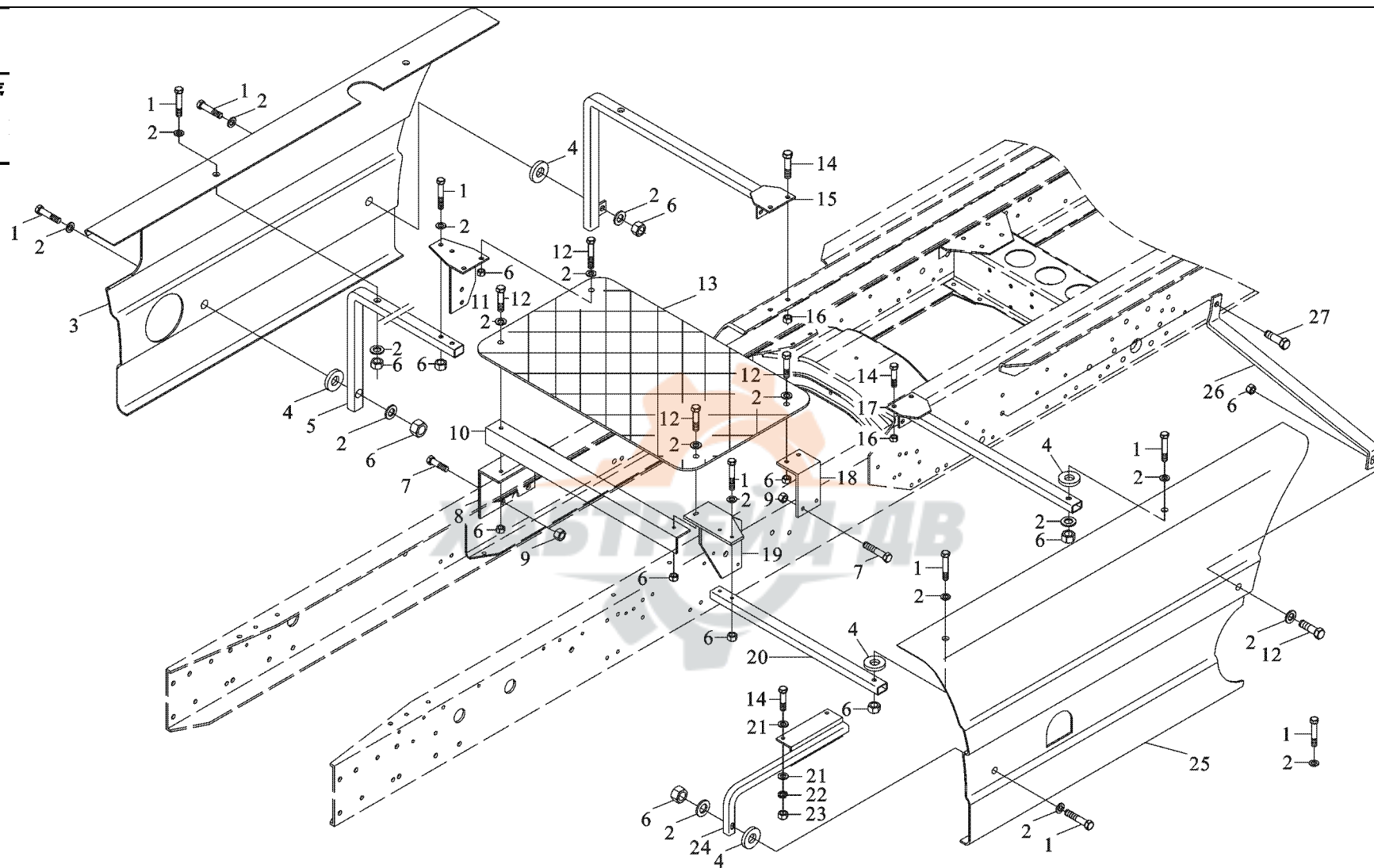

	DZ29114931301	侧防护板及操作平台	Side protect plate and operating flat roof	1		
	DZ2911493120 1	侧防护板及操作平台	Side protect plate and operating flat roof	1		
1		六角头螺栓	Hex screw	11		
2	Q150B0850	大垫圈	Washer	22		
3	Q40208	右侧护板	Right side protect plate	1		
4	DZ1600871227	减振垫	Cushion	8		
5	AZ9114930301	支撑管	Support pipe	1		
6	DZ9114931223	Ⅱ型全金属六角锁紧螺 母	Locking nut	15		
7	Q33208		Hex screw	4		
8	Q150B1450	六角头螺栓	Bracket I	1		
9	DZ9114930644	支架（一）	Locking nut	4		
10	Q33214	Ⅱ型全金属六角锁紧螺 母	Strengthen cross member	2		
11	DZ9114930235		Right front bracket assy	1		
12	DZ9112930340	加强梁	Hex screw	5		
13	Q150B0825	右前支架总成	Operating flat roof	1		
14	DZ9114930214	六角头螺栓	Hex screw	10		
15	Q150B1030	操作平台	Bracket (rear)	1		
16	DZ9114931220	六角头螺栓	Locking nut	8		
17	Q33210	支架总成（后）	Bracket	1		
18	AZ9100930166	Ⅱ型全金属六角锁紧螺 母	Bracket Ⅱ	1		
19	DZ9114930214		Left front bracket assy	1		
20	DZ9114930210	支架总成	Support pipe	1		
21	DZ9114930211	支架（二）	Washer	4		

侧护板及操作平台      SIDE PROTECT PLATE AND OPERATING FLAT ROOF



侧  
序

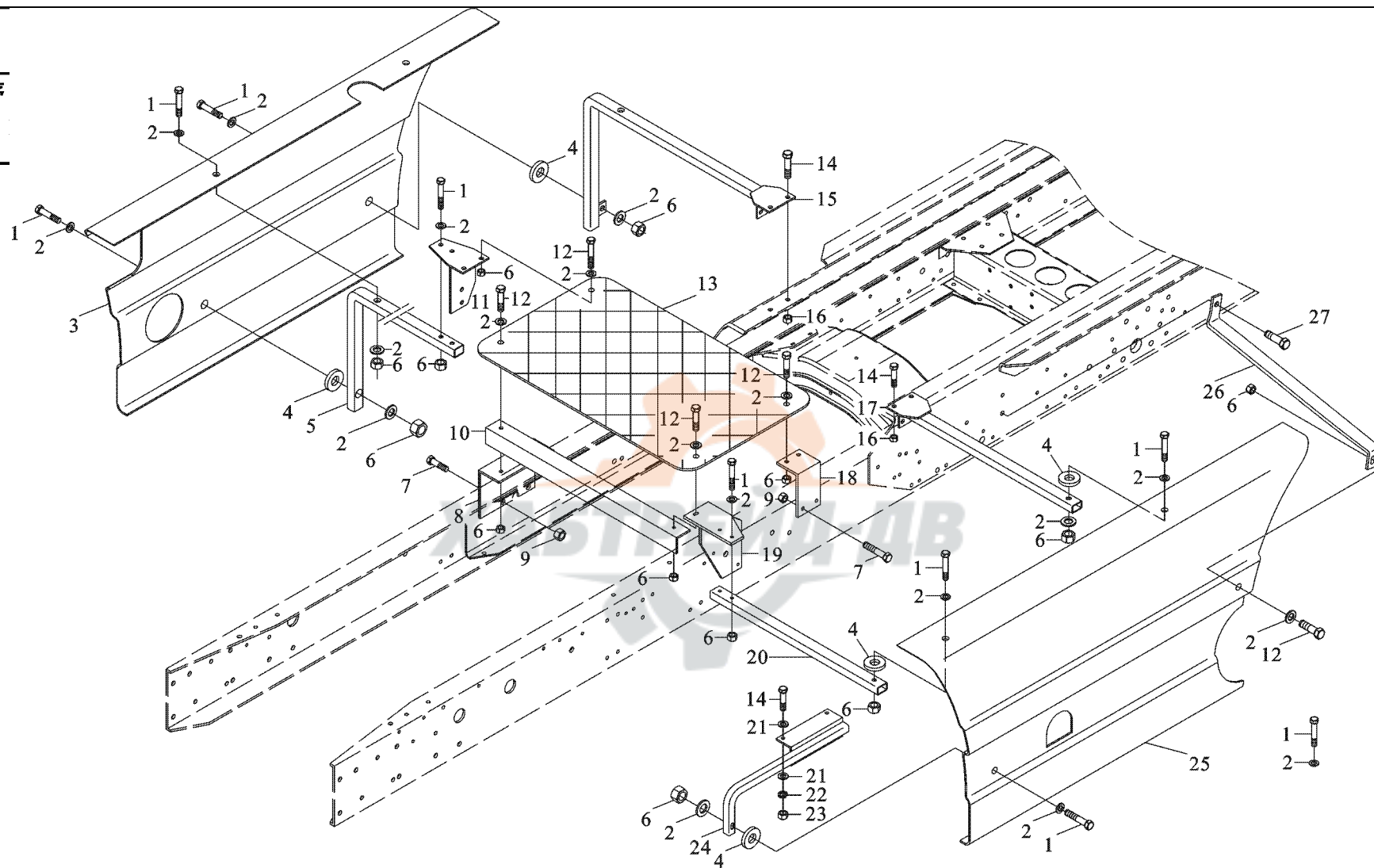

22	Q40310	弹簧垫圈	Spring washer	2		
23	Q340B10	I 型六角螺母	Hex nut	2		
24	AZ9114930370	撑管总成	Support pipe assy	1		
25	DZ1600870026	左侧护板	Left side protect	1		
26	AZ9114930217	左后下支架	Left rear barcket (lower)	1		
27	Q150B1245	六角头螺栓	Hex screw	1		



鞍式牵引座 SEMI TRAILING BASE

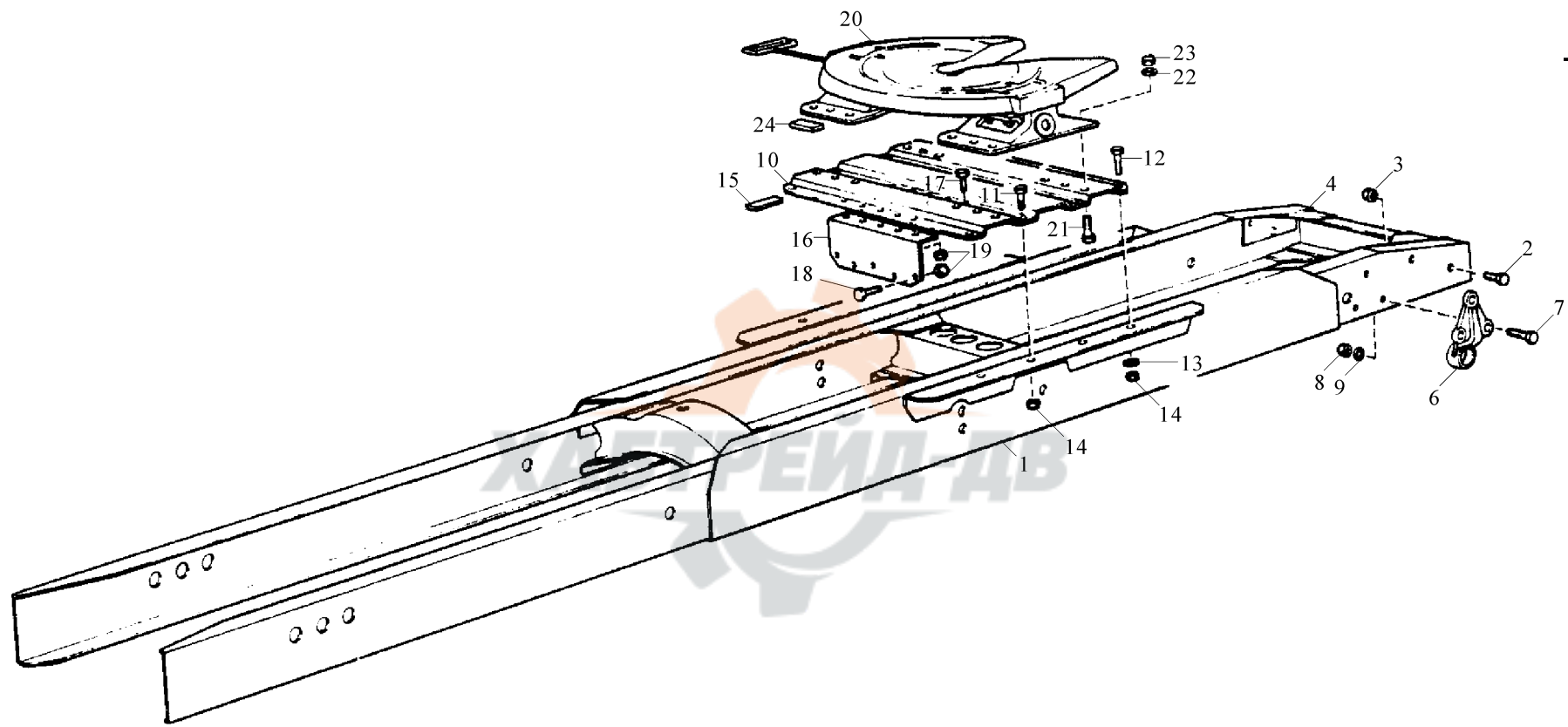

	AZ911493000	单摆 50 鞍座	Single shake 50 semi trailing base		
	99114930076	单摆90鞍座	Single shake 90 semi trailing base		
	AZ911493000	约斯特50鞍座	Eurost 50 semi trailing base		
	AZ911493000	双摆50鞍座	Double shake 50 semi trailing		
	AZ911493000	双摆90鞍座	base		
1	99114512440	车 架	Double shake 90 semi trailing		
2	99100510104	螺 栓	base		
3	90003888620	螺 母	Chassis frame		
4	99112510342	横 梁	Screw		
6	99100510008	支 架	Nut		
7	99012310124	螺 栓	Cross member		
8	90003888627	螺 母	Bracket		
9	90003930301	垫 圈	Screw		
10	99112510349	板	Nut		
11	90003803823	螺 栓	Washer		
12	90003803819	螺 栓	Plate		
13	-99-907-030	垫 圈	Screw		
14	90003888459	螺 母	Screw		
15	99100510102	垫 板	Washer		
16	99114512451	连接板	Nut		
	99112510322	连接板	Sheet		
	99114512452	连接板	Connection plate		
17	90003803643	螺 栓	Connection plate		
18	90003803633	螺 栓	Connection plate		
19	90003888457	螺 母	Screw		

鞍式牵引座 SEMI TRAILING BASE

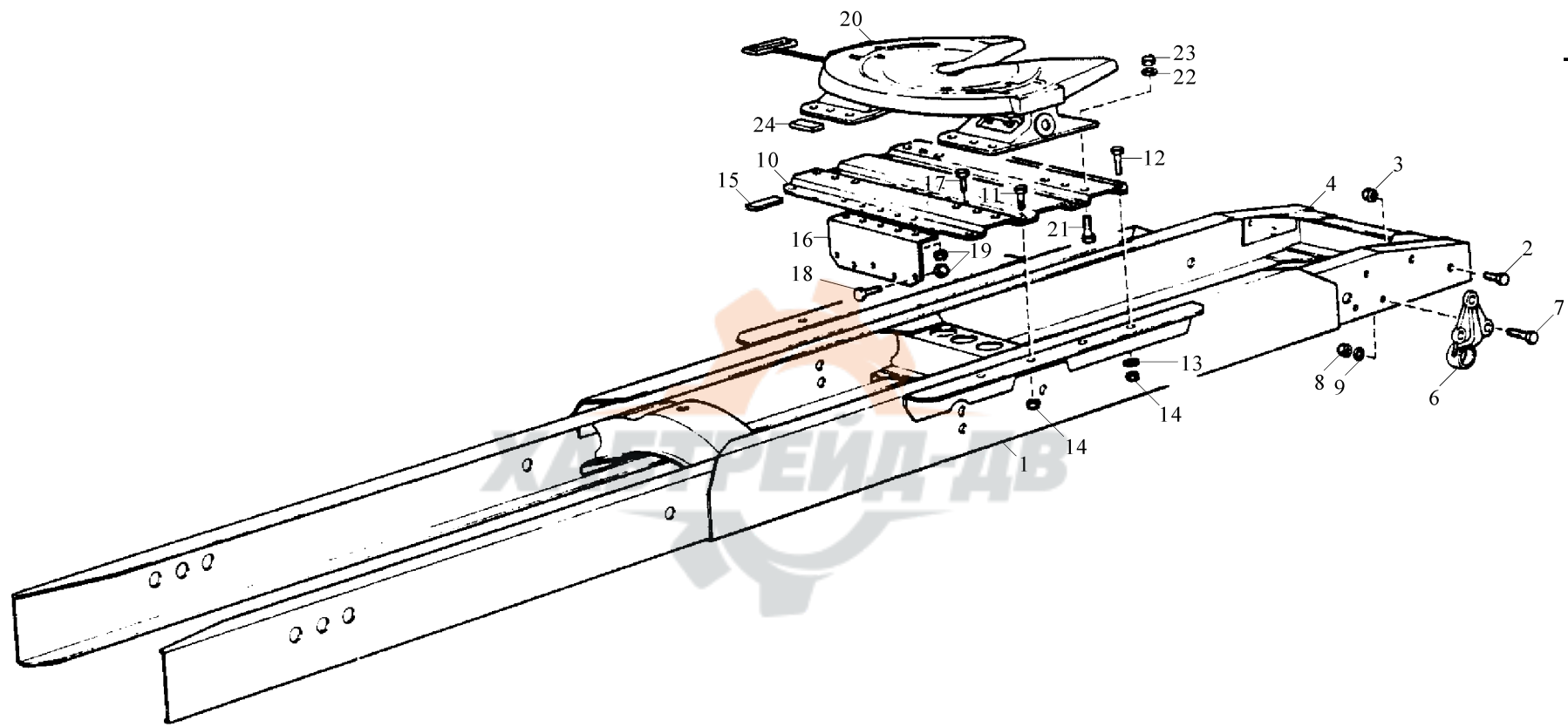

20	99112930106	鞍 座	Semi-clutch			
21	90003803839	螺 栓	Screw			
22	90003937830	垫 圈	Washer			
23	90003888459	螺 母	Nut			
24	780 S 930009	止推板	Stop piece			



前 悬 架 ( 4×2 6×4 ) FRONT SUSPENSION 4×2 6×4

前 悬

序 号

NC

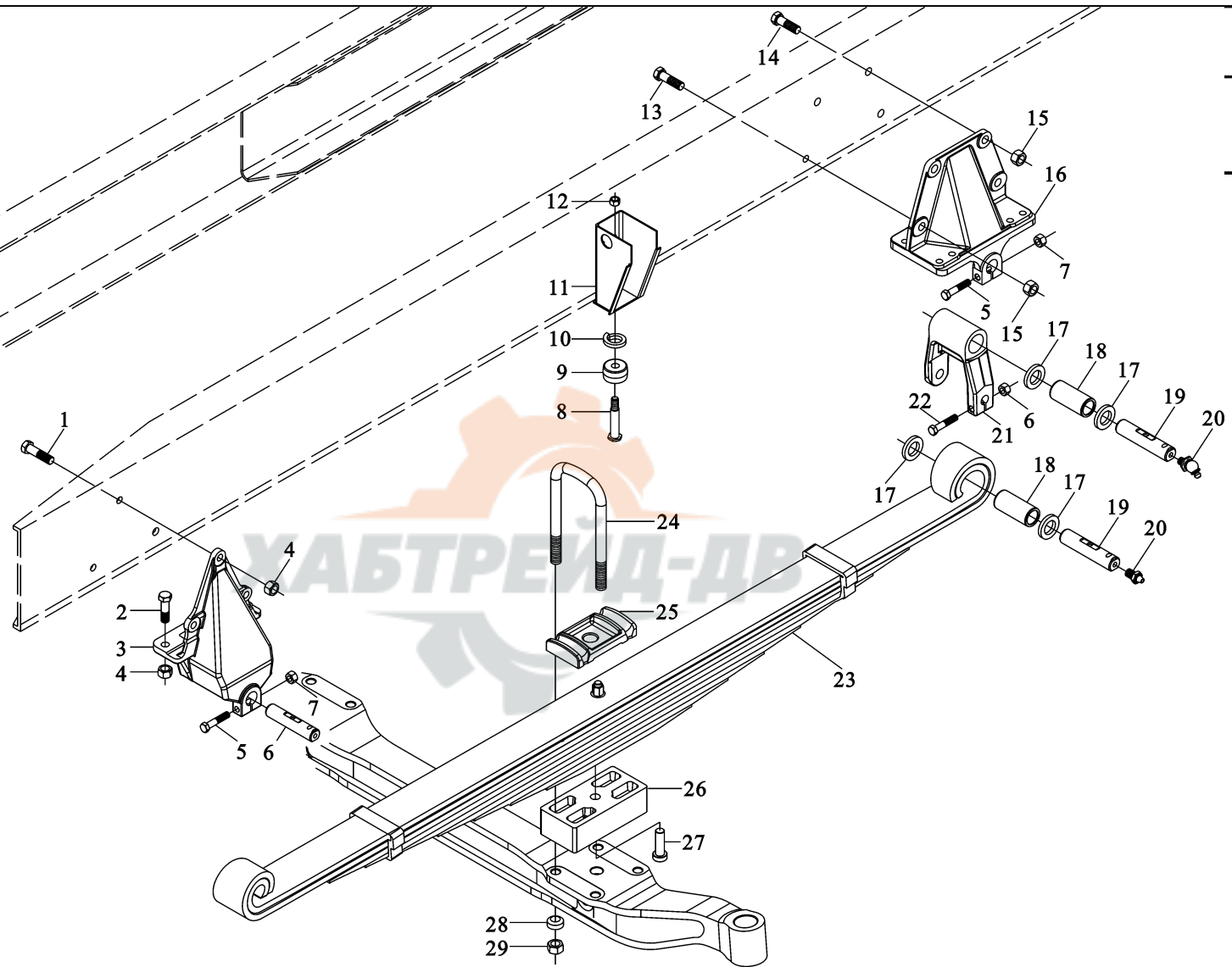

1	90003803757	螺 栓	Hex screw	6	(4×2 6×4)	
2	90003803746	螺 栓	Hex screw	4		
3	DZ9100520010	前簧前支架	Bracket	2		
	99100520010	前簧前支架	Bracket	2		
4	90003888458	螺 母	Nut	10		
5	90003803674	螺 栓	Stud	4		
6	DZ9114520005	□ 簧□	Bolt	1		
7	90003888457	螺 母	Nut	6		
8	880 520019	□ 固件	Fastening part	2		
9	880 520017	前簧限位□	Spring block	2		
10	90003931122	□ 簧□ 圈	Spring washer	2		
11	99114680014	□ 冲□ 支架	Cushion	2		
12	90003871305	螺 母	Nut	2		
13	90003803846	螺 栓	Screw	2		
14	90003803844	螺 栓	Screw	6		
15	90003888459	螺 母	Nut	8		
16	99100520115	前簧左后支架	Bracket	2		4×2
	99114520285	前簧左后支架	Bracket	2		6×4
	99114520286	前簧右后支架	Bracket	2		6×4
	99100520156	前簧右后支架	Bracket	2		4×2
17	680 520050	□ 圈 □	Washer	12		
18	99000520078	吊耳□ 套	Bush	6		
19	99100520005	□ 簧□ □	Bolt	6		
	99100520006	□ 簧□ □	Bolt	6		

前 悬 架 ( 4×2 6×4 ) FRONT SUSPENSION 4×2 6×4



前悬

序号

NC

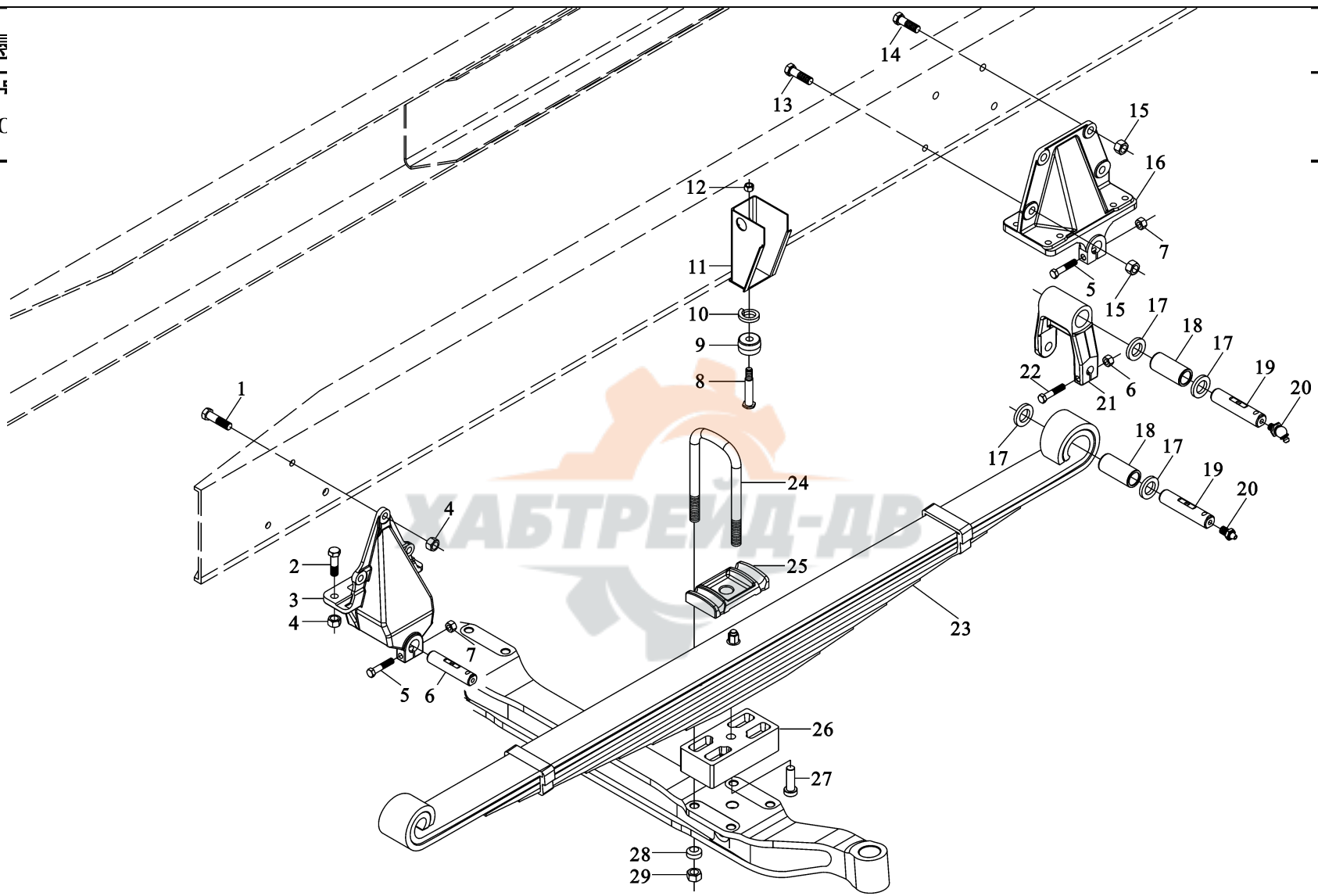

20	90003963127	油嘴 (前、后、左)	Nipple(front rear left)	6		
	90003963112	油嘴 (前、后、左)	Nipple(front rear left)	6		
21	99100520034	前簧吊耳□ 戒	Spring shackle	2		
	99100520018	前簧吊耳	Spring shackle	2		
22	90003803666	螺 栓	Screw	2		
23	DZ9100529004	前左□ 板□ 簧□ 戒	Leaf spring left	1		
	DZ9100529005	前右簧板□ 簧□ 戒	Leaf spring right	1		
24	DZ9100520007	□ □ 螺栓	Screw	4		
25	880 520002	前簧□ 板	Plate	2		
26	99014520304	□ 簧座	Spring base	2		□ 用于 6×4 □
27	99000520006	□ 向□	Bolt	2		
28	680 520056	□ 圈 □	Washer	8		
	680 520043	□ 圈 □	Washer	8		
29	90003888626	螺 母	Nut	8		

前 悬 架 ( 8×4 ) FRONT SUSPENSION 8×4

前

F

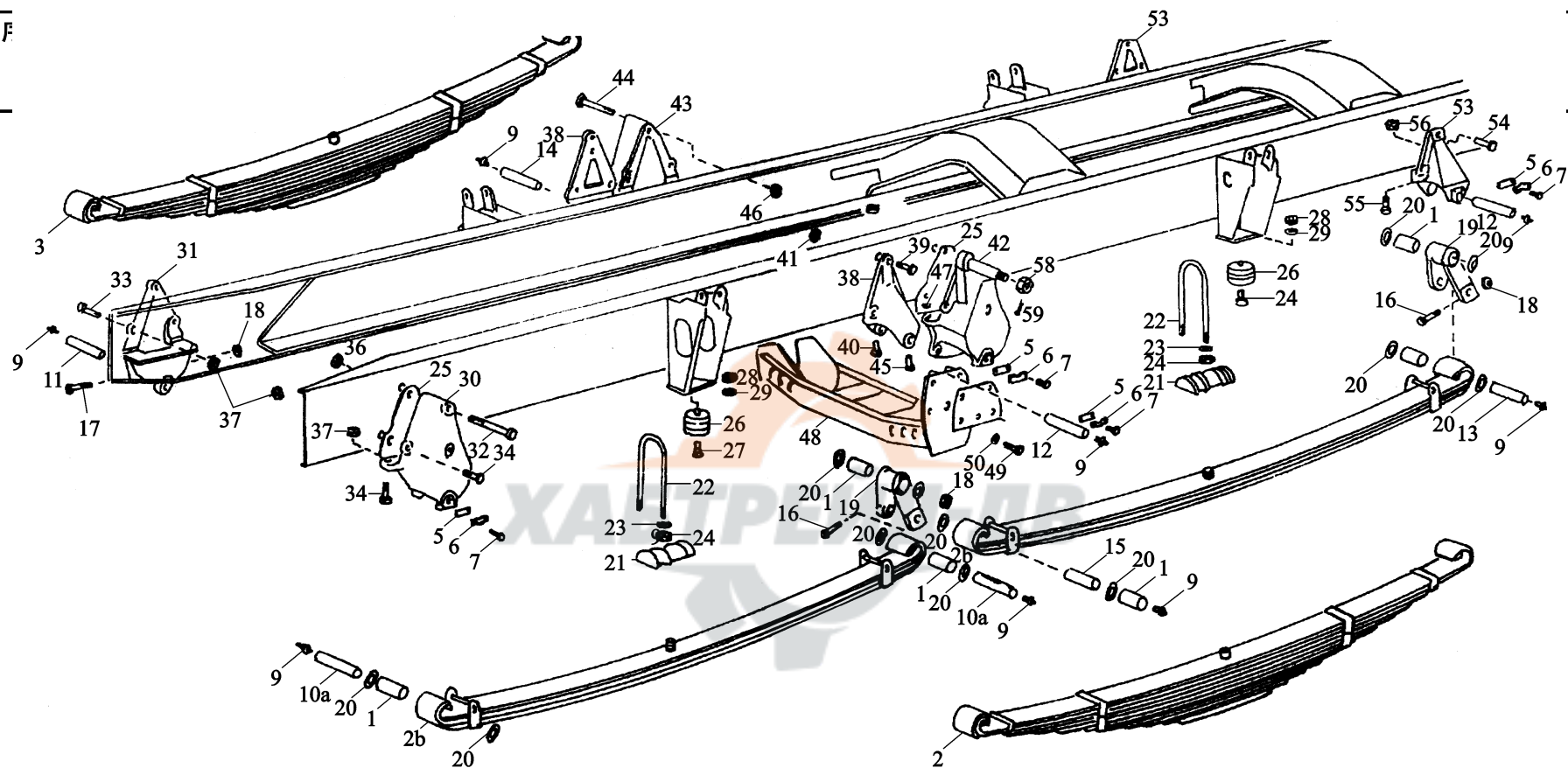

1	99100520078	□ 套	Bush	12		
2	DZ9118529001	左前□ 板□ 簧□ 戒□(14	Spring ( left )	2		
3	DZ9118529002	片)	Leaf spring assy	14		
7	90003802419	右前□ 板□ 簧□ 戒□(13	Screw	12		
9	90003963115	片)	Oil nipple	1		
10	89000520015	螺 栓	Spring	5		
10a	99100520065	油 嘴	Spring	4		
12	99000520080	□ 簧□	Spring	2		
14	79000520040	□ 簧□	Screw	4		
16	90003803666	□ 簧□	Screw	1		
17	90003803674	□ 簧□	Screw	5		
18	90003888457	□ 簧□	Nut	4		
19	99100520034	螺 栓	Support,shackle	24		
20	680 520050	螺 栓	Washer	4		
21	880 520002	螺 母	Plate	8		
22	880 520001	吊耳支架	Screw	16		
23	680 520043	□ 圈 □	Washer	16		
24	90003888626	前簧□ 板	Nut	2		
25	99018520001	□ □ 螺栓	Plate	4		
26	880 520017	□ 圈 □	Cushion	4		
27	880 520019	螺 母	Bolt	4		
28	90003871305	□ 板 □	Nut	4		
29	90003931122	□ 冲□ □	Spring washer	1		
30	99000520058	□ 固□	Bracket,left	1		
31	99100520010					

前 悬 架 ( 8×4 ) FRONT SUSPENSION 8×4

前  
F

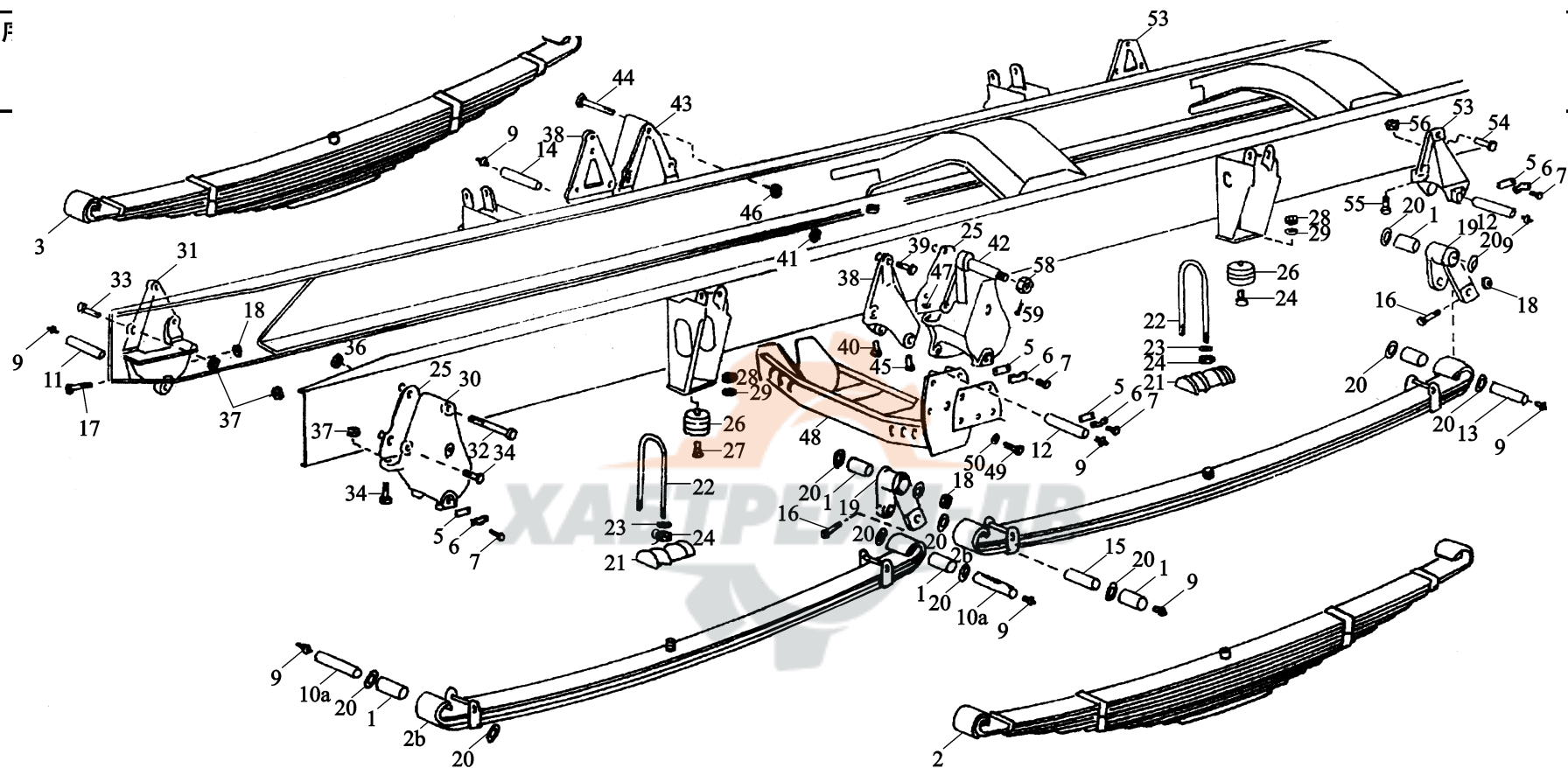

32	90003803882	螺 栓	Screw	1		
33	90003803751	螺 栓	Screw	3		
34	90003803753	螺 栓	Screw	2		
34	90003803743	螺 栓	Screw	4		
36	90003888459	螺 母	Nut	1		
37	90003888458	螺 母	Nut	9		
38	79000520050	前簧后支架	Rear bracket	2		
39	90003803743	螺 栓	Screw	8		
40	90003803743	螺 栓	Screw	2		
41	90003888458	螺 母	Nut	10		
42	99118520011	左前簧前支架	Bracket ( left )	1		
43	99118520010	右前簧前支架	Bracket ( right )	1		
44	90003803872	螺 栓	Screw	2		
45	90003803743	螺 栓	Screw	8		
46	90003888459	螺 母	Nut	2		
47	90003888458	螺 母	Nut	8		
48	DZ9118520120	鞍形横梁	Cross member	1		
	99118520001	鞍形横梁	Cross member	1		
49	90003803737	螺 栓	Screw	8		
50	90003935432	□ 形□ 圈	Washer	8		
53	99018520006	前簧后支架	Bracket	2		
54	90003803746	螺 栓	Screw	6		
55	90003803743	螺 栓	Screw	2		
56	90003888458	螺 母	Nut	8		
58	90003872381	花螺母	Screw	1		

前 悬 架 ( 8×4 ) FRONT SUSPENSION 8×4

前  
F

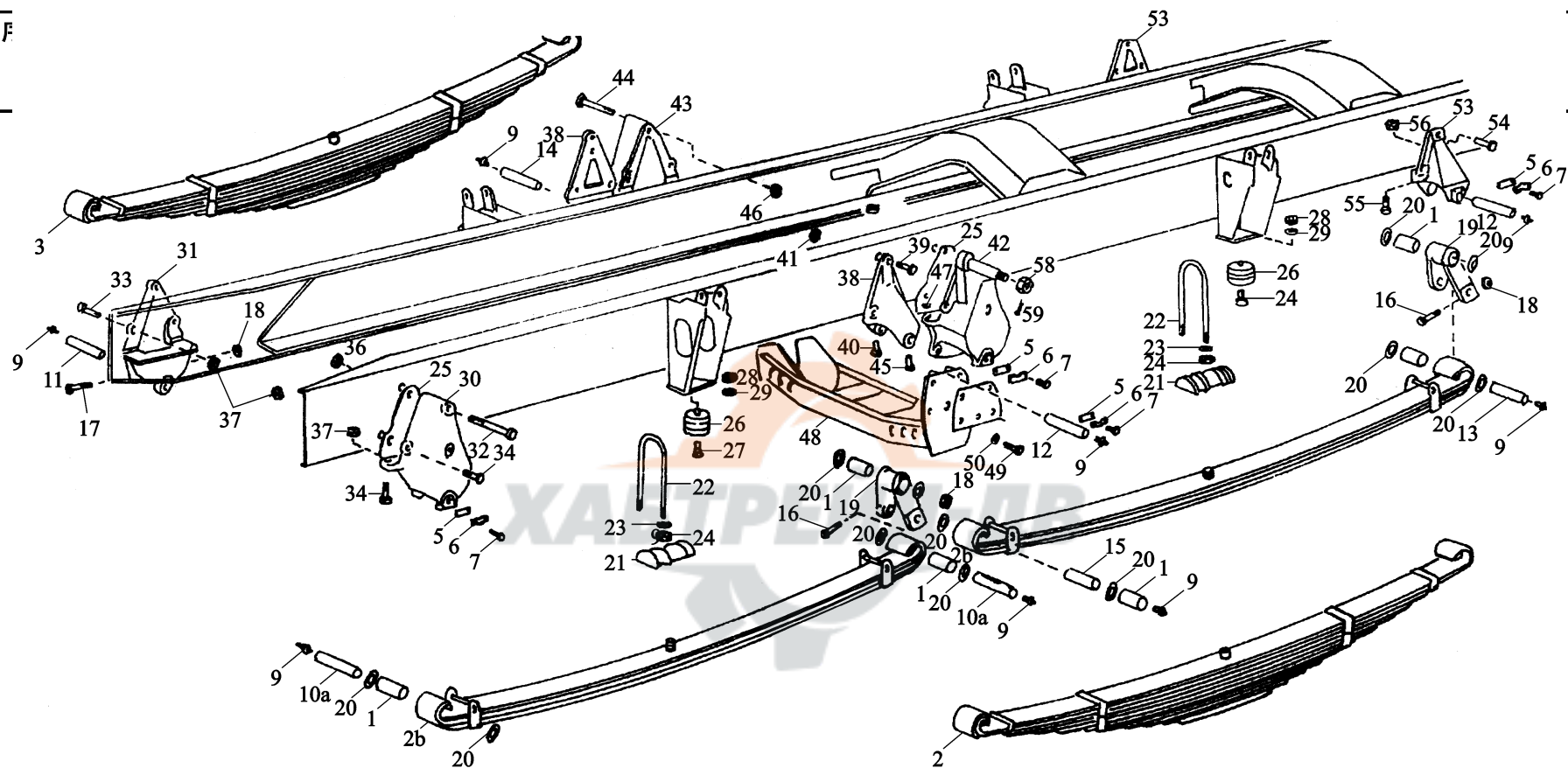

59	90003920541	□ □□	Cotter pin	1		
60	99000520096	保□帽	Protective cap			



后 悬 架 （ 4×2 ） REAR SUSPENSION 4×2



后  
序

I

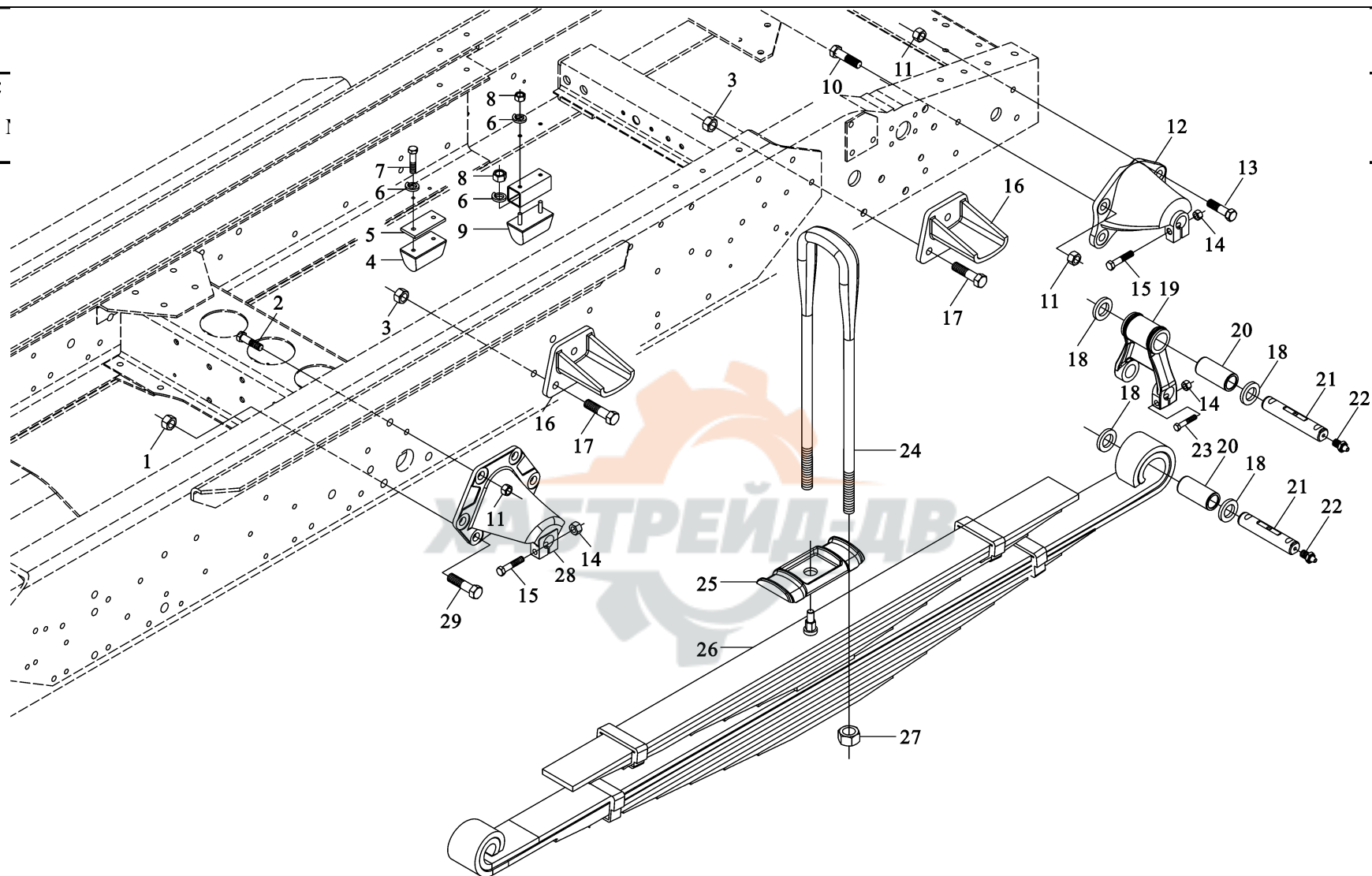

1	90003808626	螺 母	Nut	4		
2	90003803839	六角□ 螺栓	Hex screw	8		
	90003803819	六角□ 螺栓	Hex screw	8		
3	90003888458	自□ 螺母	Locking nut	12		
4	99012520011	后□ 限位□ □ 戚	Limit block	2		
5	99012520012	板	Plate	2		
6	90003931122	□ 簧□ 圈	Spring washer	4		
7	90003800536	螺 栓	Hex screw	4		
8	90003871305	螺 母	Nut	4		
9	199012520011	□ 冲□ □	Cushion	2		
10	90003803839	六角□ 螺栓	Hex screw	4		
11	90003888459	自□ 螺母	Locking nut	12		
12	99100520013	后簧后支架	Bracket	2		
	AZ9100520110	后簧后支架	Bracket	2		□ 用于4×2 低位鞍式□ 引□ to lower saddle towing truck
13	90003803819	六角□ 螺栓	Hex screw	8		
14	90003888457	自□ 螺母	Locking nut	6		
15	90003803694	六角□ 螺栓	Hex screw	4		
16	99112520081	限位支架□ 戚	Bracket	4		
17	90003803743	螺 栓	Hex screw	12		
	90003803753	螺 栓	Hex screw	12		
18	680 520050	□ 圈 □	Washer	12		
19	99100520019	后□ 簧吊耳	Spring shackle rear	2		
20	99000520079	□ 套 □	Bush	4		
21	99100520006	板簧□ □	Bolt	6		

## 后 悬 架 （ 4×2 ） REAR SUSPENSION 4×2

后  
序

I

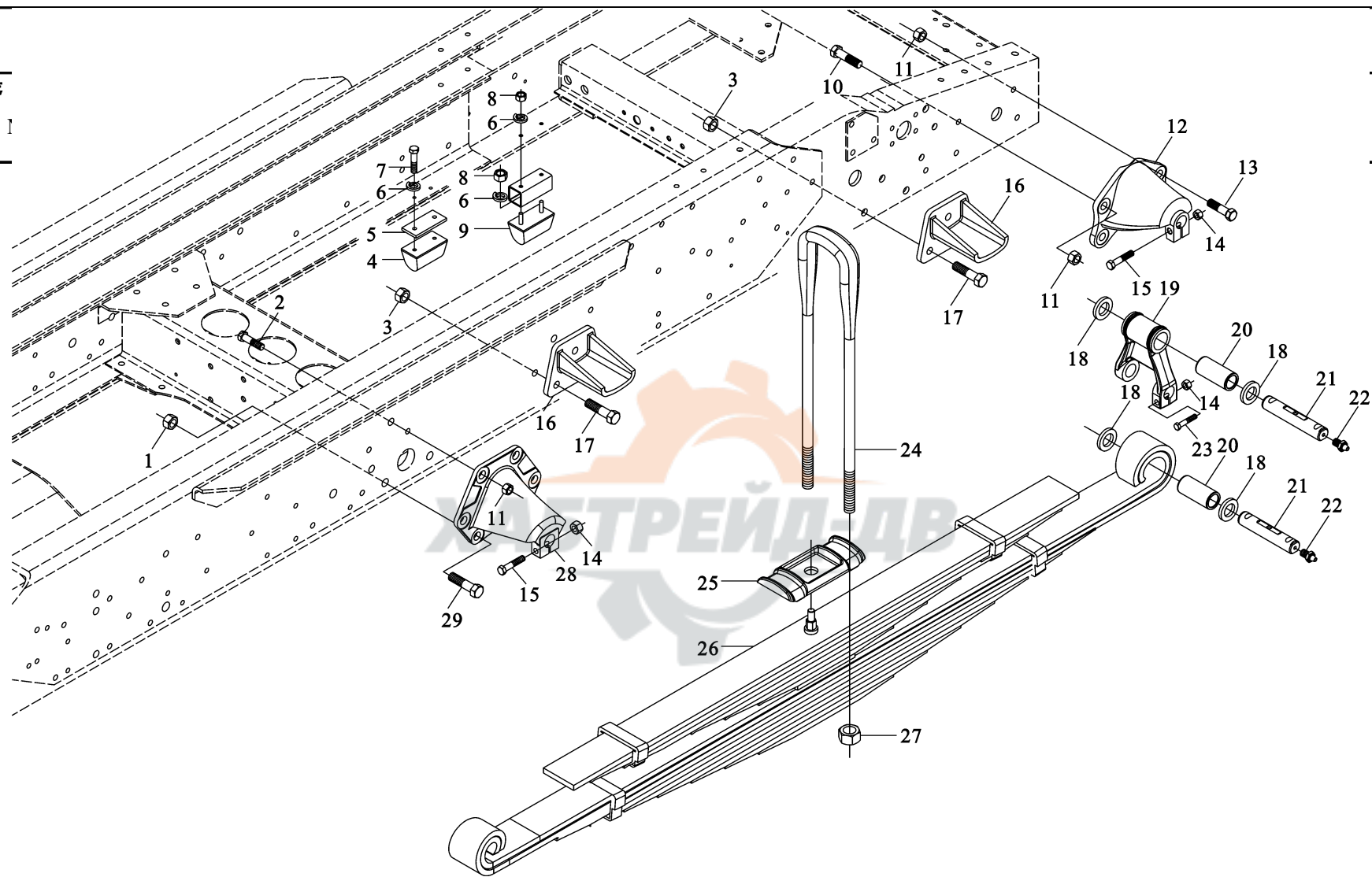

22	90003963124	米制 螺 滑脂嘴	Oil nipple	6		AM10×1 DIN
23	90003803674	六角 螺 栓	Hex screw	2		
24	99100520037	后 簧 螺 栓	Screw	4		
25	99100520020	簧 板	Plate	2		
26	99112520004	后 板 簧 成	Leaf spring rear	2		
27	90003888630	自 螺 母	Locking nut	8		
28	99100520012	后 簧 前 支 架	Bracket	2		
29	90003803960	六角 螺 栓	Hex screw	4		

平衡悬架（一） BALANCING SUSPENSION I

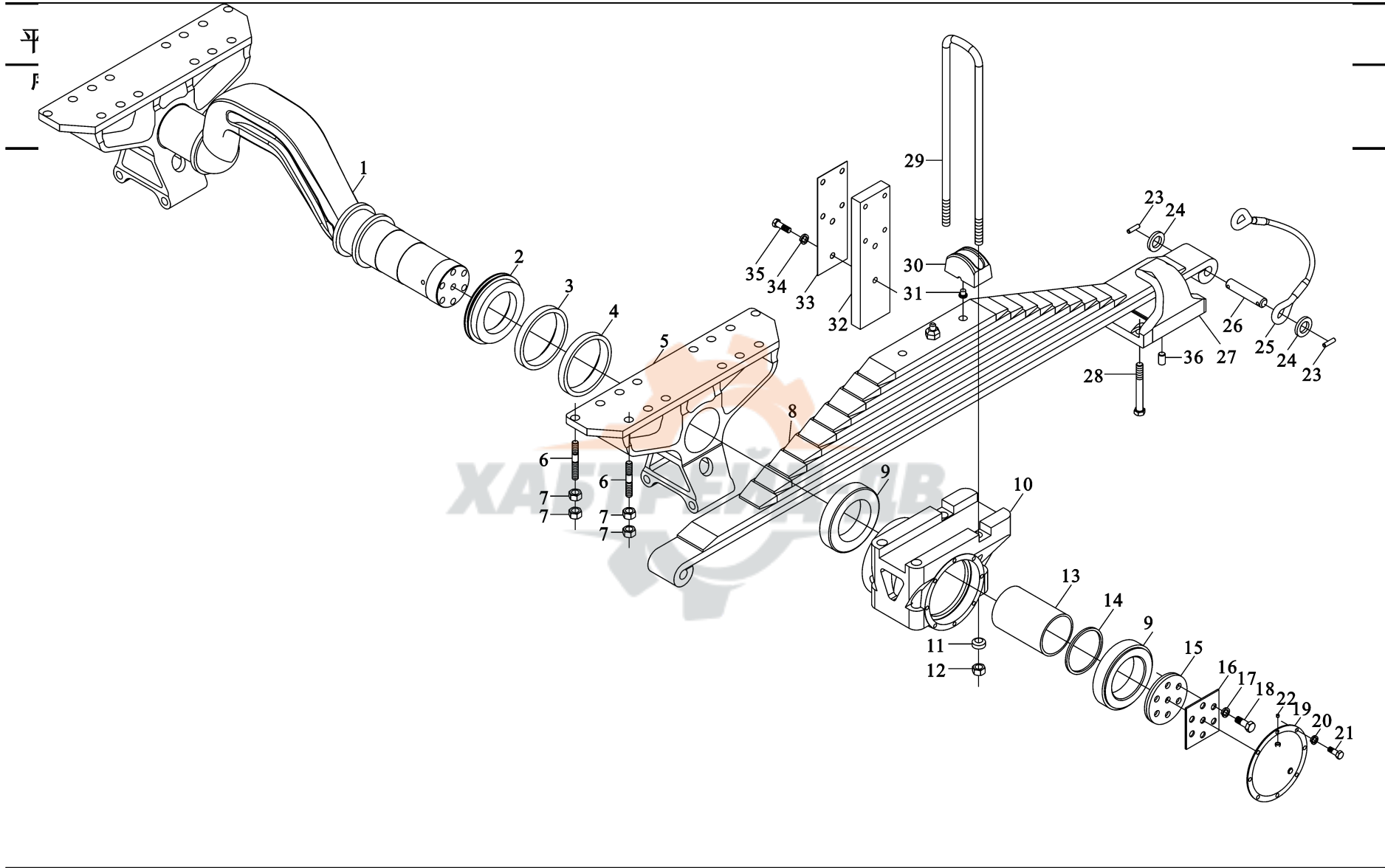

1	99114520168	平衡轴总成	Balancing shaft assy	1	6×4、8×4	后 架 rear suspension
2	99114520136	轴承油封盖	Bearing seal cover	2		
3	99114520222	密封圈	Seal-ring	2		
	90003074394	密封圈	Seal-ring	2		
	99014520195	密封圈	Seal-ring	2		
4	61400130062	轴密封圈	Seal-ring	2		
5	99014520217	支 架	Bracket	2		
6	99014520227	双头螺栓	Stud	28		
	99014520228	双头螺栓	Stud	28		
7	90003871353	I 型六角螺母（细牙）	Hex nut	28		
8	99114520060	后钢板弹簧总成	Leaf spring rear	2		
9	99114520042	球面轴承	Bearing	4		
10	99114520035	平衡轴壳	Axle housing	2		
11	188340022	垫 圈	Washer	8		
12	90003888749	自锁薄螺母	Locking nut	8		
13	99014520191	间隔衬套	Bush	2		
14	99014520192	定位垫圈	Washer	2		
15	99014520188	轴承压板	Plate	2		
16	AZ9114520188	止动垫圈	Stop washer	2		
17	Q40316	弹簧垫圈	Spring washer	8		
18	90003803809	六角头螺栓	Hex screw	12		
19	DZ9114520311	壳 盖	Cover	2		
20	90003931102	弹簧垫圈	Spring washer	16		
21	90003802419	六角头螺栓	Hex screw	16		
22	90003962021	锥螺纹内六角螺塞	plug	2		

平 衡 悬 架 （ 一 ） BALANCING SUSPENSION I

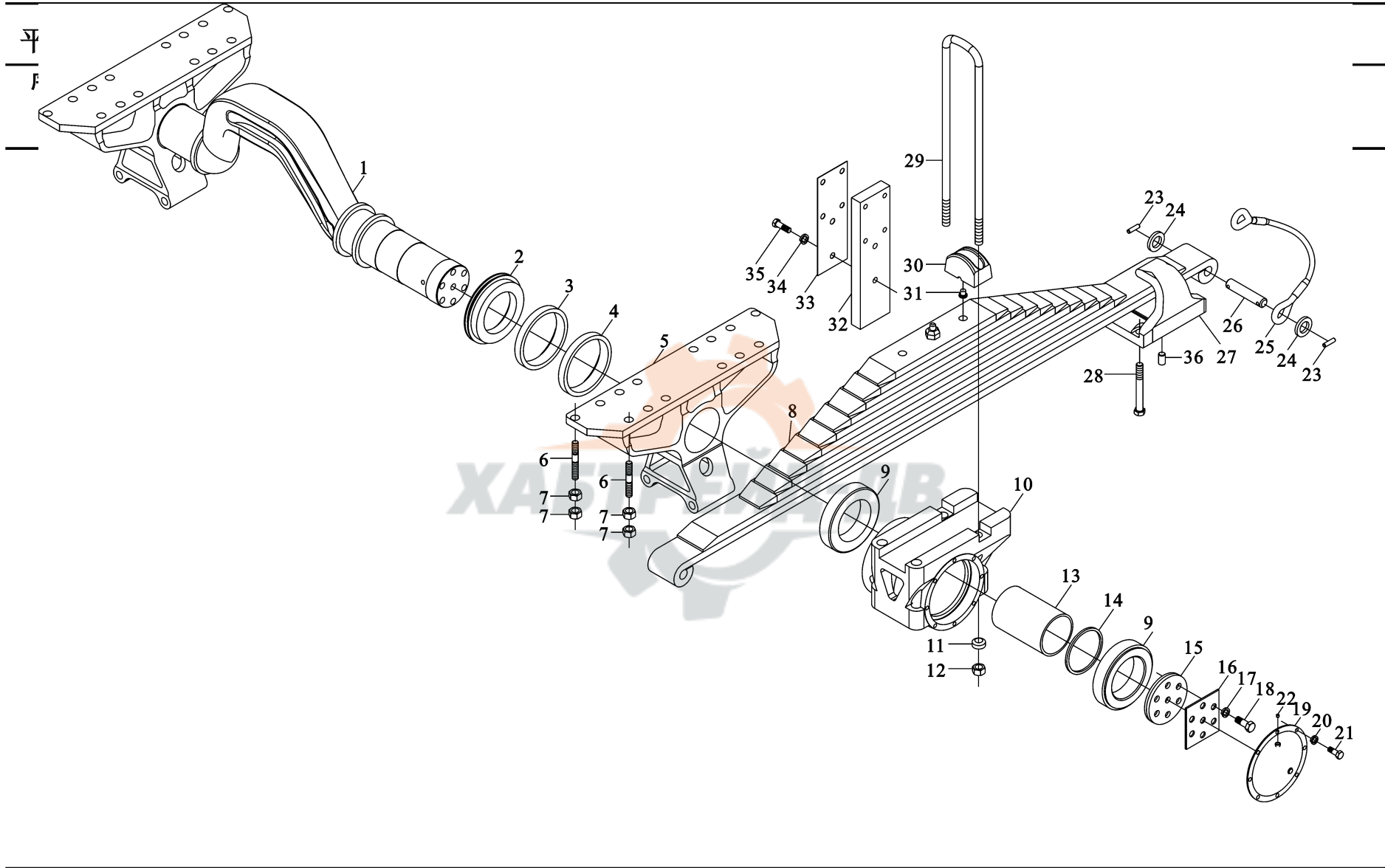

23	90003909654	弹性圆柱销	Cyl.pin	4		Q5280840
	90003909659	弹性圆柱销	Cyl.pin	4		Q5280860
24	88 270078	垫 圈	washer	4		
25	99114520292	限位链条	limit chain	4		
	99114520293	限位链条	limit chain	4		
26	99014520019	□ 子 □	Bolt	4		
27	99014520294	□ 板□ 簧座	Spring clip plate	4		
28	90003803985	螺 栓	Screw	16		
29	99014520208	后簧□ □ 螺栓	Spring clip	4		
30	99000520021	□ □ 螺栓座	Screw base	4		
31	99000520006	□ 向□	Bolt	4		
32	99114520147	□ 向板	Plate	4		
33	99014520224	平衡板	Plate	4		
34	90003931162	□ 簧□ 圈	Spring washer	4		
35	90003803753	六角□ 螺栓	Hex screw	4		
36	99014520256	□	pin	4		

平衡悬架（二） BALANCING SUSPENSION II



平衡

序号

NO

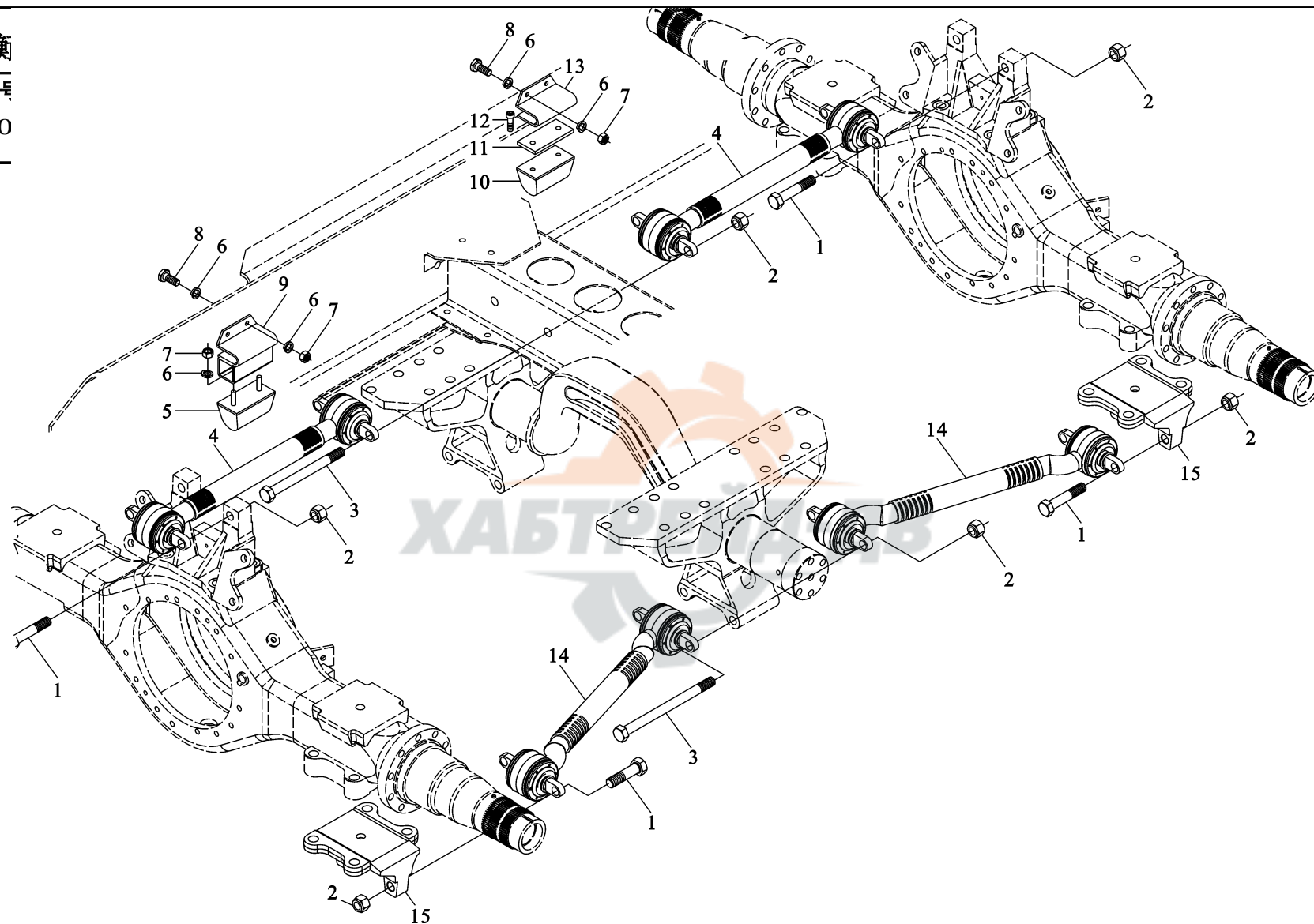

1	9000380007	螺 栓	Hex screw	12	6×4、8×4	M20×1.5×90
2	90003888467	自锁螺母	Locking nut	18		
3	90003803974	六角头螺栓	Hex screw	2		后□ 架Rear suspension
	90003800008	六角头螺栓	Hex screw	4		M20×1.5×240
4	99014520174	上推力杆总成	Push rod assy	2		Q151B20200 M20×1.5×200
5	58600520021	限位块总成	Limit block	2		
6	90003931122	弹簧垫圈	Srping washer	8		
7	90003871305	I 型六角螺母	Hex nut	8		
8	90003800529	六角头螺栓	Hex screw	4		
9	99114520057	限位块支架总成	Bracket	2		
10	99012520011	限位块总成	Limit block	2		
11	99012520012	板	Plate	2		
12	90003862024	内六角型沉头螺钉	Screw	4		Q2581035
13	99114520026	U 形夹	U shape clip	2		
14	99014520175	下推力杆总成	Lower push rod	4		
15	99014520292	右下推力杆支架	Bracket	2		
	99014520293	左下推力杆支架	Bracket	2		

前 稳 定 架 总 成 ( 6×4 4×2 ) FRONT STABILIZER ASSY 6×4 4×2

前 稳

序 号

NO

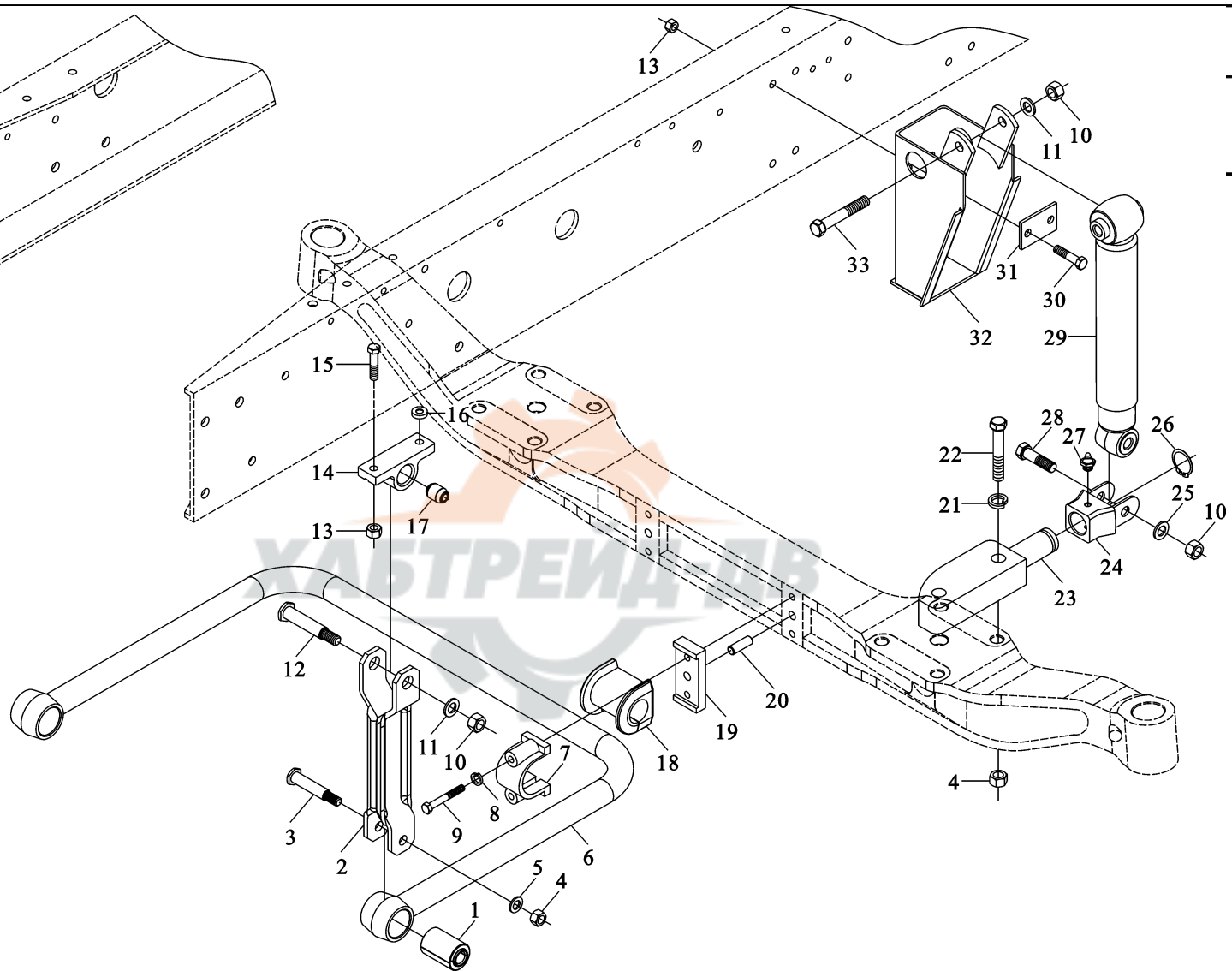

1	99100680052	□ 套合件	Sleeve set	2	
2	99100680055	吊板□ 戒	Clip	2	
3	99100680069	螺 栓	Hex screw	2	
4	90003888458	自□ 螺母	Locking nut	2	
5	90003930291	平□ 圈	Flat washer	2	Q40114
6	99100680048	□ 定杆	Stabilizer assy	1	
7	880 68 24	固定□ 板	Bearing	2	
	880 00 24	固定□ 板	Bearing		
8	90003931122	□ 簧□ 圈	Spring washer	4	Q40310
9	90003802578	螺 栓	Hex screw	4	
10	90003888459	自□ 螺母	Locking nut	4	
11	9003930301	小□ 圈	Washer	4	
12	99100680057	螺 栓	Hex screw	2	
13	90006888457	自□ 螺母	Locking nut	12	
14	99100680053	支架□ 戒	Bracket	2	
15	90003803646	六角□ 螺栓	Hex screw	4	
16	DZ9100680015	□ 圈 □	Wahser	2	Q151C1250
17	99100680054	□ 套 □	Bush	2	
18	99100680068	橡胶□ 承	Rubber bearing	2	
19	880 680027	□ 板 □	Cushion	2	
20	90003901700	□ 柱□	Cyl pin	2	Q5211424
21	90003931182	□ 簧□ 圈	Spring washer	4	
22	90003803844	螺 栓	Hex screw	4	
23	DZ9100680065	□ 交叉支座	Support	2	
24	99012680025	下支架□ 叉叉	Joint fork	2	

前 稳 定 架 总 成 ( 6×4 4×2 ) FRONT STABILIZER ASSY 6×4 4×2

前 稳

序 号

NO

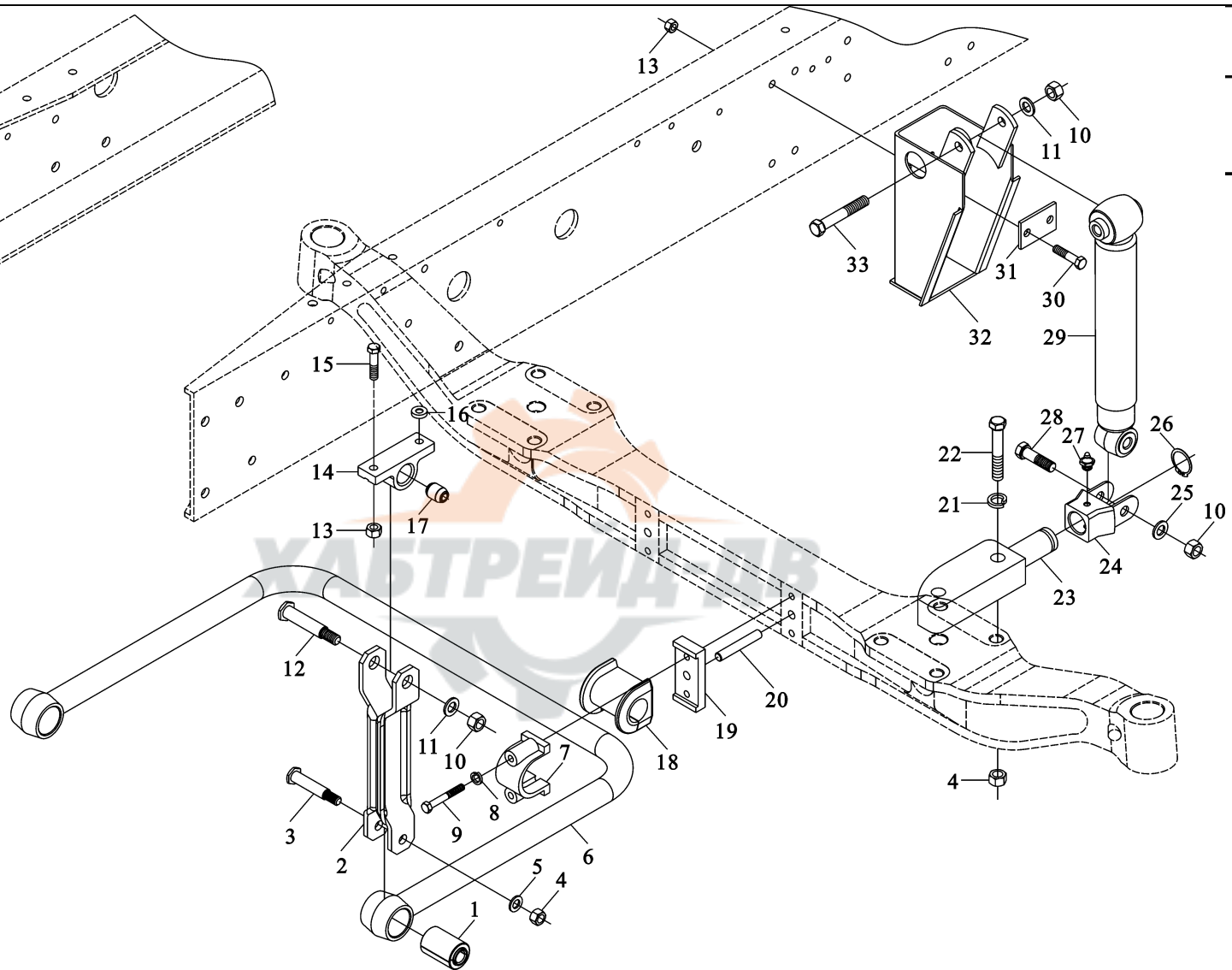

25	90003930301	小□ 圈	Washer	2		
26	90003933242	□ 用□ 牲□ 圈	Circlip	2		
27	90003963112	油 嘴	Oil nipple	2		
28	99012680009	螺 栓	Hex screw	2		
29	99104680004	减振器	Shock absorber	2		
	99100680001	减振器	Shock absorber	2		
30	90003803645	螺 栓	Hex screw	8		
31	99100680021	□ 板 □	Cushion	4		
32	DZ9100680020	减振器支架	Bracket	2		
33	99100680036	螺 栓	Hex screw	2		

前 稳 定 架 总 成 ( 8×4 ) FRONT STABILIZER ASSY 8×4

前  
序

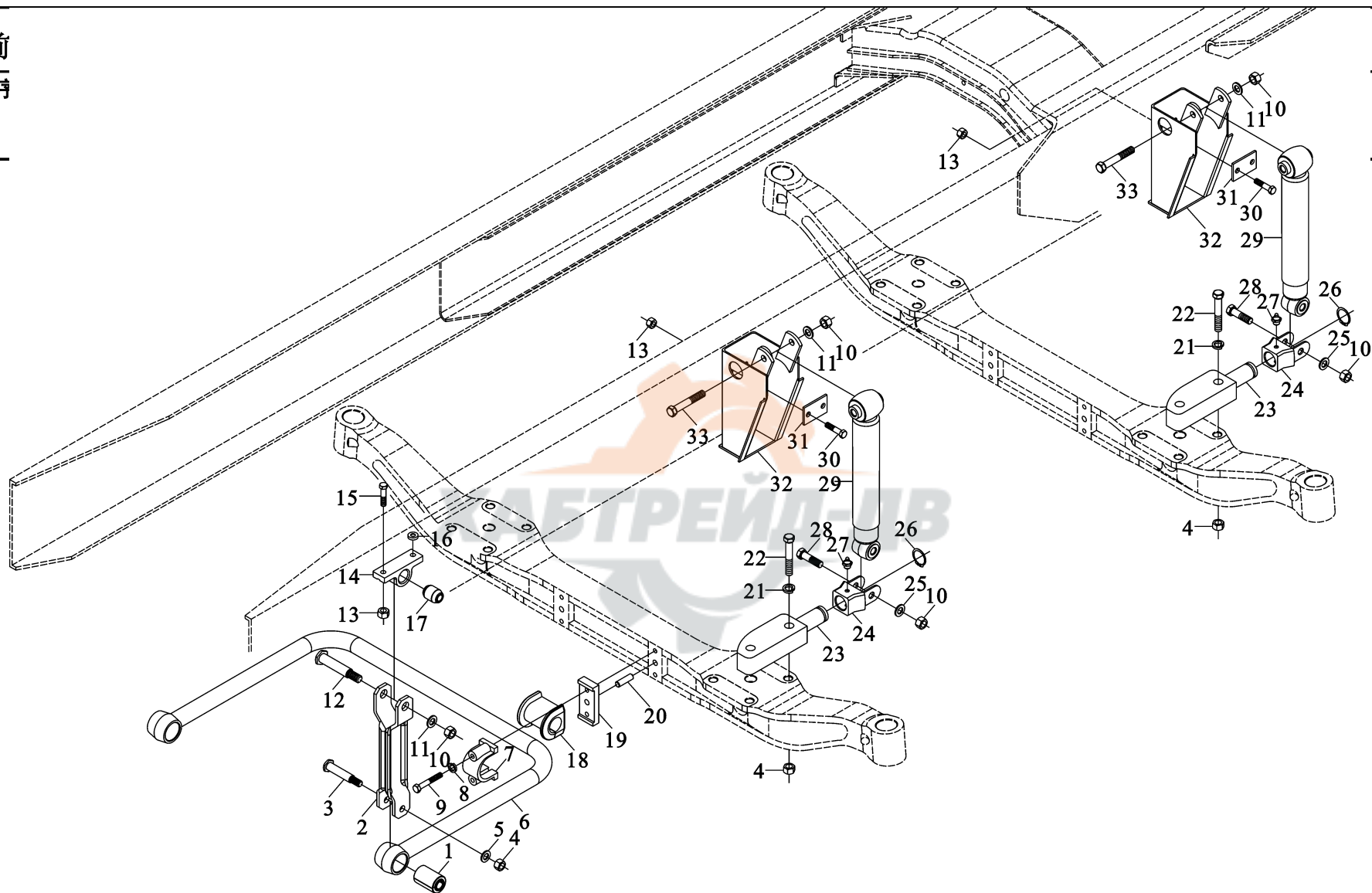

1	99100680052	□ 套合件	Sleeve set	2	
2	99100680055	吊板□ 戒	Clip	2	
3	99100680069	螺 栓	Hex screw	2	
4	90003888458	自□ 螺母	Locking nut	2	
5	90003930291	平□ 圈	Flat washer	2	Q40114
6	99100680050	□ 定杆	Stabilizer	1	
7	880 680024	固定□ 板	Bearing	2	
8	90003931122	□ 簧□ 圈	Spring washer	4	Q40310
9	90003802578	螺 栓	Hex screw	4	
10	90003888459	自□ 螺母	Locking nut	8	
11	90003930301	小□ 圈	Washer	6	
12	99100680057	螺 栓	Hex screw	2	
13	90006888457	自□ 螺母	Locking nut	20	
14	99100080053	支架□ 戒	Bracket	2	
	99100680047	支架□ 戒	Bracket	2	
15	90003803646	六角□ 螺栓	Hex screw	4	Q151C1250
16	99100680070	□ 圈 □	Washer	4	
17	99100680054	□ 套 □	Bush	2	
18	99100680068	橡胶□ 承	Rubber bearing	2	
19	880 680027	□ 板 □	Cushion	2	
20	90003901700	□ 柱□	Cyl pin	2	Q5211424
21	90003931182	□ 簧□ 圈	Spring washer	8	
22	90003803844	螺 栓	Hex screw	8	
23	DZ9100680065	支 架	Bracket	4	
24	99012680025	下支架□ 叉	Joint fork	4	

前 稳 定 架 总 成 ( 8×4 ) FRONT STABILIZER ASSY 8×4



前  
序

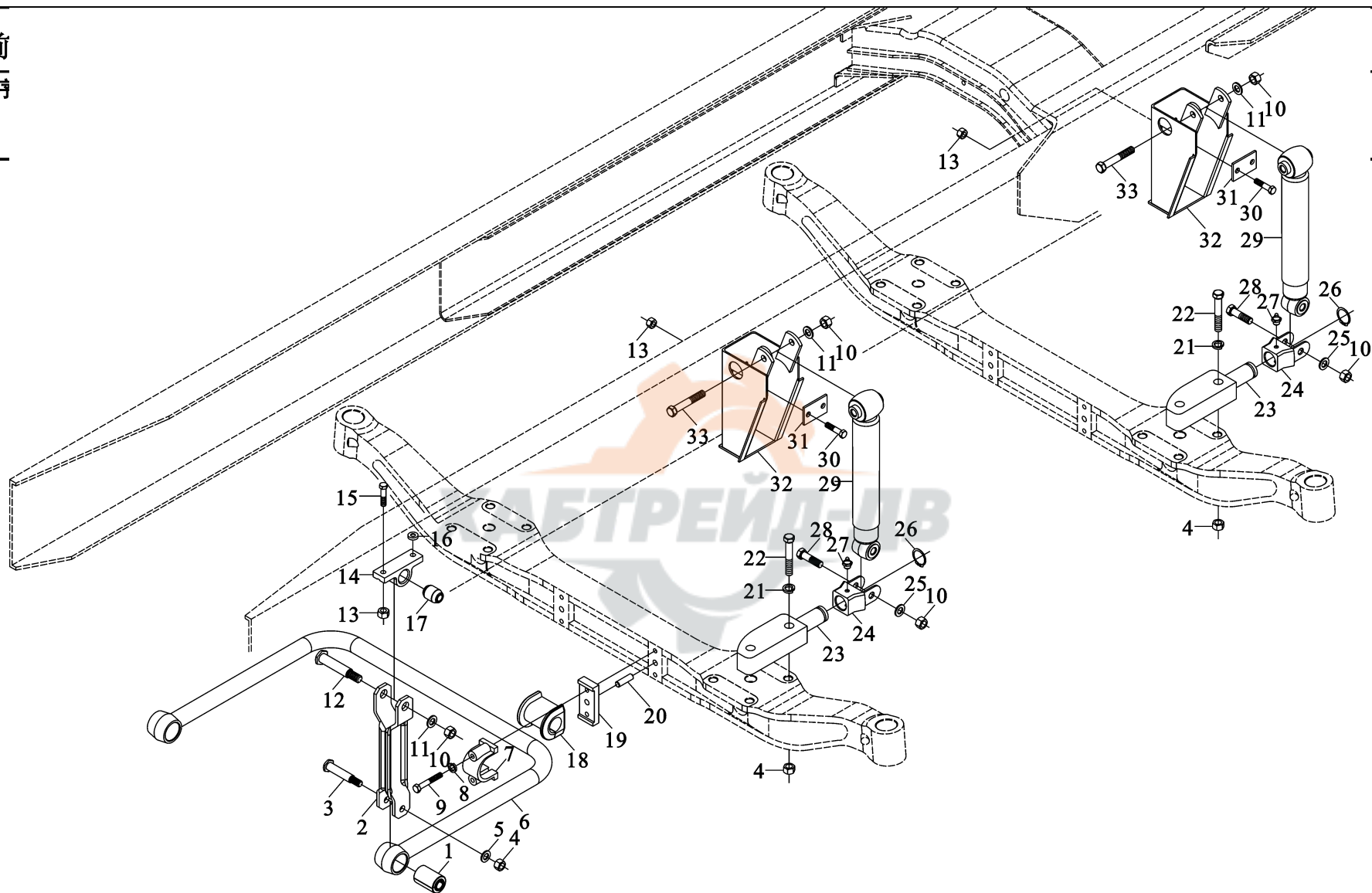

25	90003930301	小□ 圈	Washer	4		
26	90003933242	□ 用□ 牲□ 圈	Circlip	4		
27	90003963112	油 嘴	Oil nipple	4		
28	99012680009	螺 栓	Hex screw	4		
29	99112680014	减振器	Shock absorber	4		
30	90003803643	六角□ 螺栓	Hex screw	16		
31	99100680021	□ 板	Cushion	8		
32	99114680049	减振器支架□ 成	Bracket	2		
	99100680020	减振器支架□ 成	Bracket	2		
33	99100680036	螺 栓	Hex screw	4		

后 稳 定 器 ( 4×2 ) REAR STABLIZER 4×2

后  
序

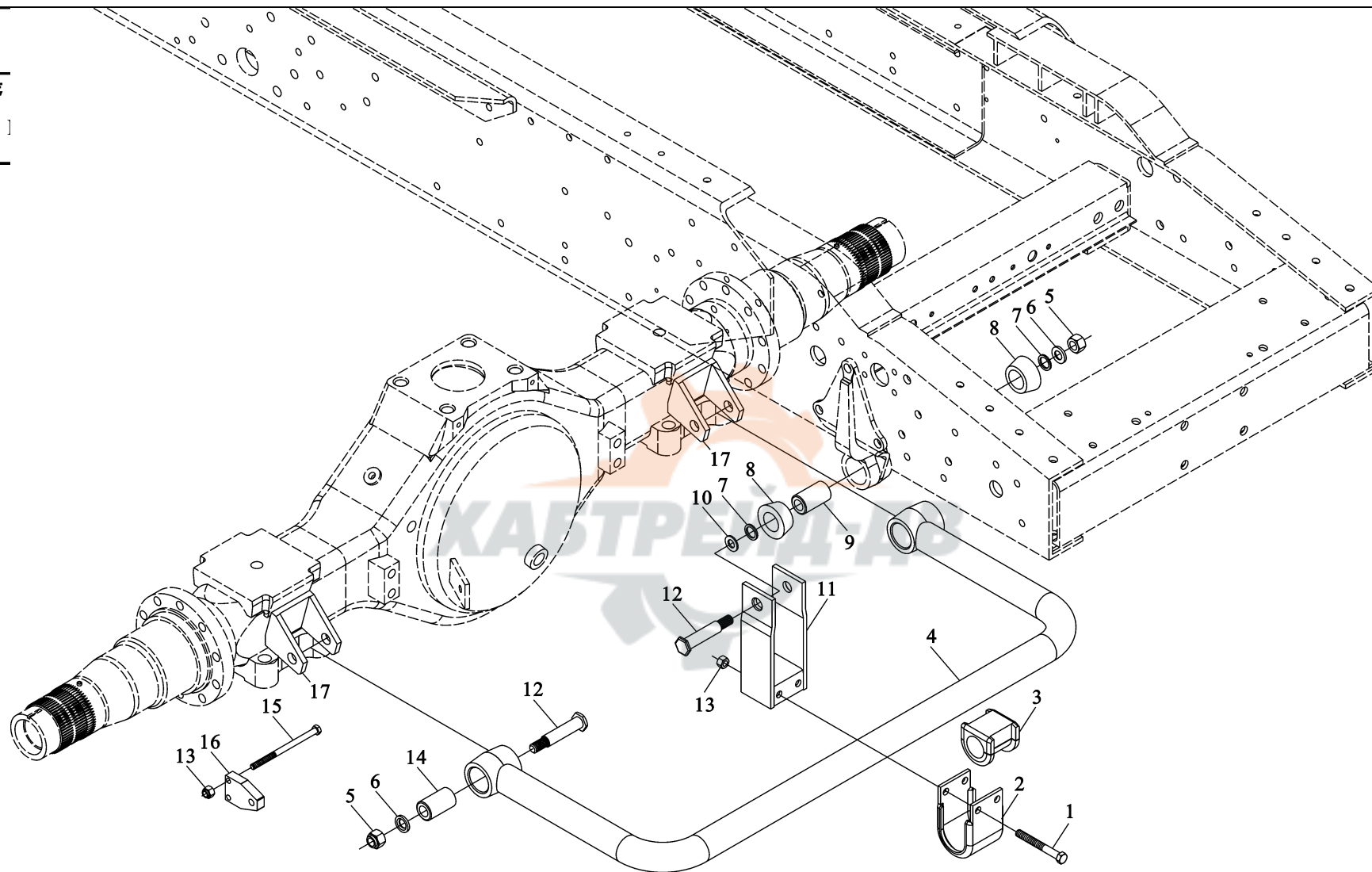

1	90003803662	六角□ 螺栓	Hex screw	4	4×2	Q151C12100
2	780 680032	□ 承□	Clip	2		
3	99100680067	橡胶□ 承	Rubber bearing	2		
4	880 680014	□ 定杆	Stabilizer	2		
5	90003888459	自□ 螺母	Locking nut	2		
6	780 680030	□ 圈 □	Washer	2		
7	680 250092	密封圈	Oil-seal	4		
8	99100680066	□ 承 □	Bearing	4		
9	99100680037	套 筒	Bush	2		
10	99100680071	□ 圈 □	Washer	2		
11	99100680016	平衡□	Clip	2		
	99100680038	平衡□	Clip	2		
12	780 680029	螺 栓	Hex screw	4		
13	90003888457	自□ 螺母	Locking nut	8		
14	780 680035	□ 套□ 件	Bush set	2		
15	90003803664	螺 栓	Hex screw	4		
16	9000680044	□ 接板	Connecting plate	4		
17	99012330019	□ 定杆固定支架	Bracket	2		

后 稳 定 器 ( 6×2 ) REAR STABILIZER 6×2

后  
月

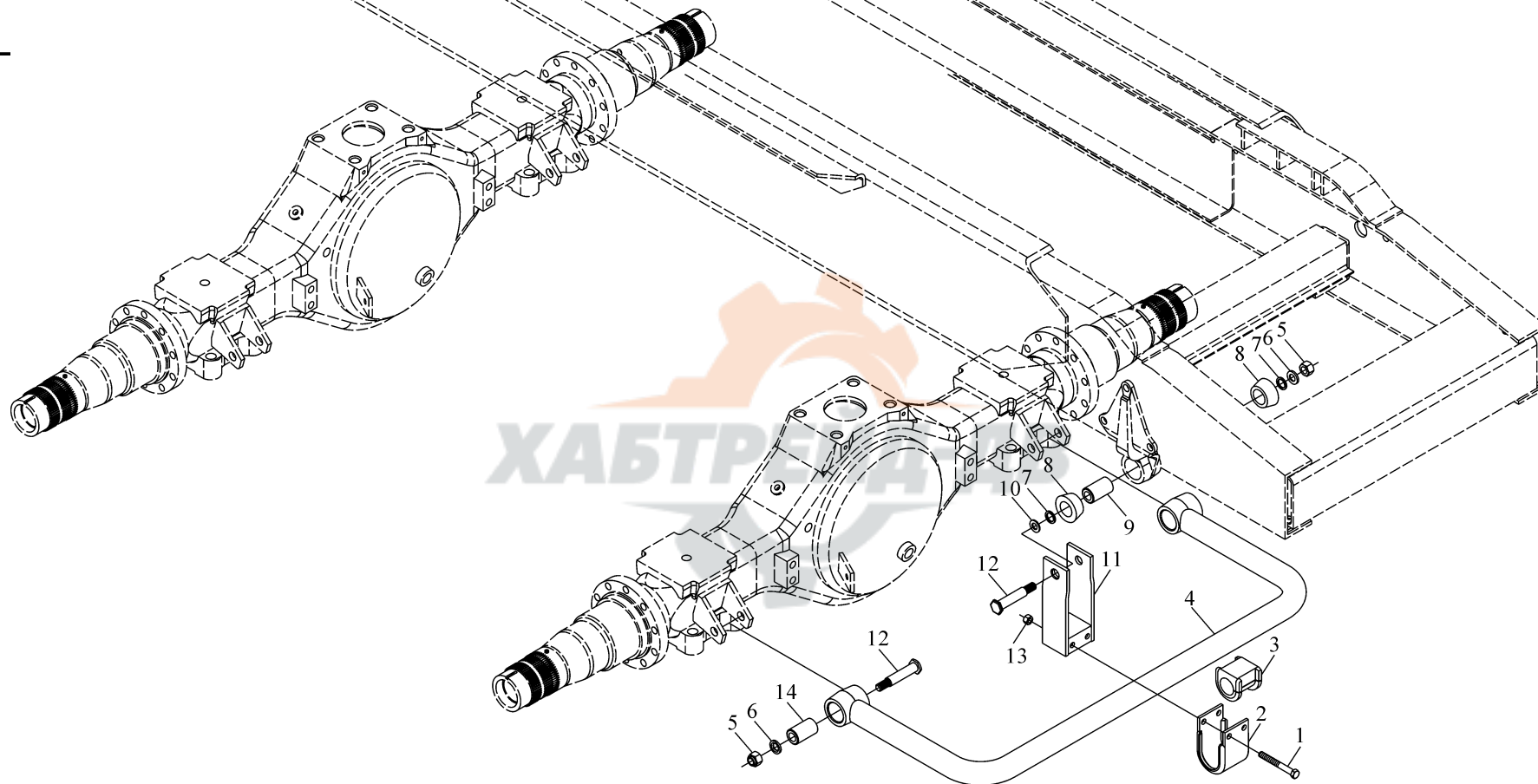

	99100680064	□ 定杆□ 成	Stabilizer assy	1		
1	90003803662	六角□ 螺栓	Hex screw	4	6×2	Q151C12100
2	780 680032	□ 承□	Clip	2		
3	99100680067	橡胶□ 承	Rubber bearing	2		
4	880 680014	□ 定杆	Stabilizer	2		
5	90003888459	自□ 螺母	Locking nut	2		
6	780 680030	□ 圈 □	Washer	2		
7	680 250092	密封圈	Oil-seal	4		
8	99100680066	□ 承 □	Bearing	4		
9	99100680037	套 筒	Bush	2		
10	99100680070	□ 圈 □	Washer	2		
11	99100680016	□ 定杆支承架	Stabilizer rod support bracket	2		
	99100680038	□ 定杆支承架	Stabilizer rod support bracket	2		
	99114680005	□ 定杆支承架	Stabilizer rod support bracket	2		
12	780 680029	螺 栓	Hex screw	2		
13	90003888457	自□ 螺母	Locking nut	8		
14	780 680035	□ 套□ 件	Bush set	2		

后 减 振 器 REAR SHOCK ABSORBER

后  
序

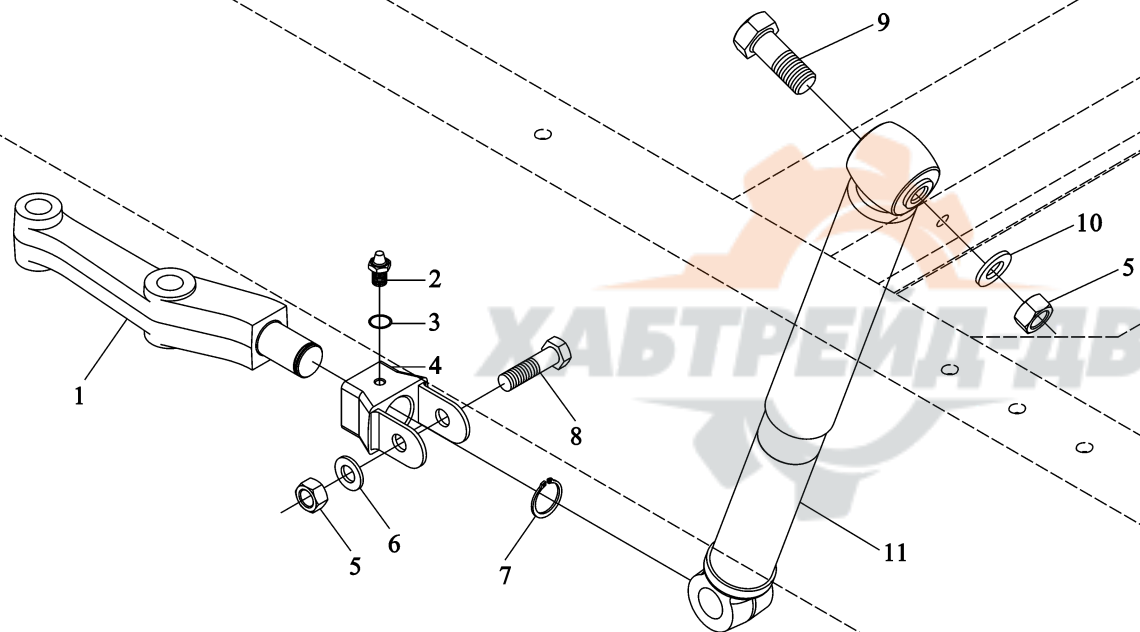

1	99114680014	□ 交叉支座	Support	2		
2	90003963112	油 嘴	Oil nipple	2		
3	90003098008	密封圈	Seal ring	2		
4	99012680025	□ 交叉支座	Support	2		
5	90003888459	螺 母	Hex nut	4		
6	90003930301	□ 圈 □	Washer	2		
7	90003933242	□ 用 □ 簧 □ 圈	Circlip	2		
8	99012680009	螺 栓	Hex screw	2		
9	99100680036	螺 栓	Hex screw	2		
10	90003932965	□ 圈 □	Washer	2		
11	99100680046	减振器	Shock absorber	2		

横 向 减 振 器 ( 8×4 ) TRANSVERSE SHOCK ABSORBER 8×4



横向游

序号  
NO

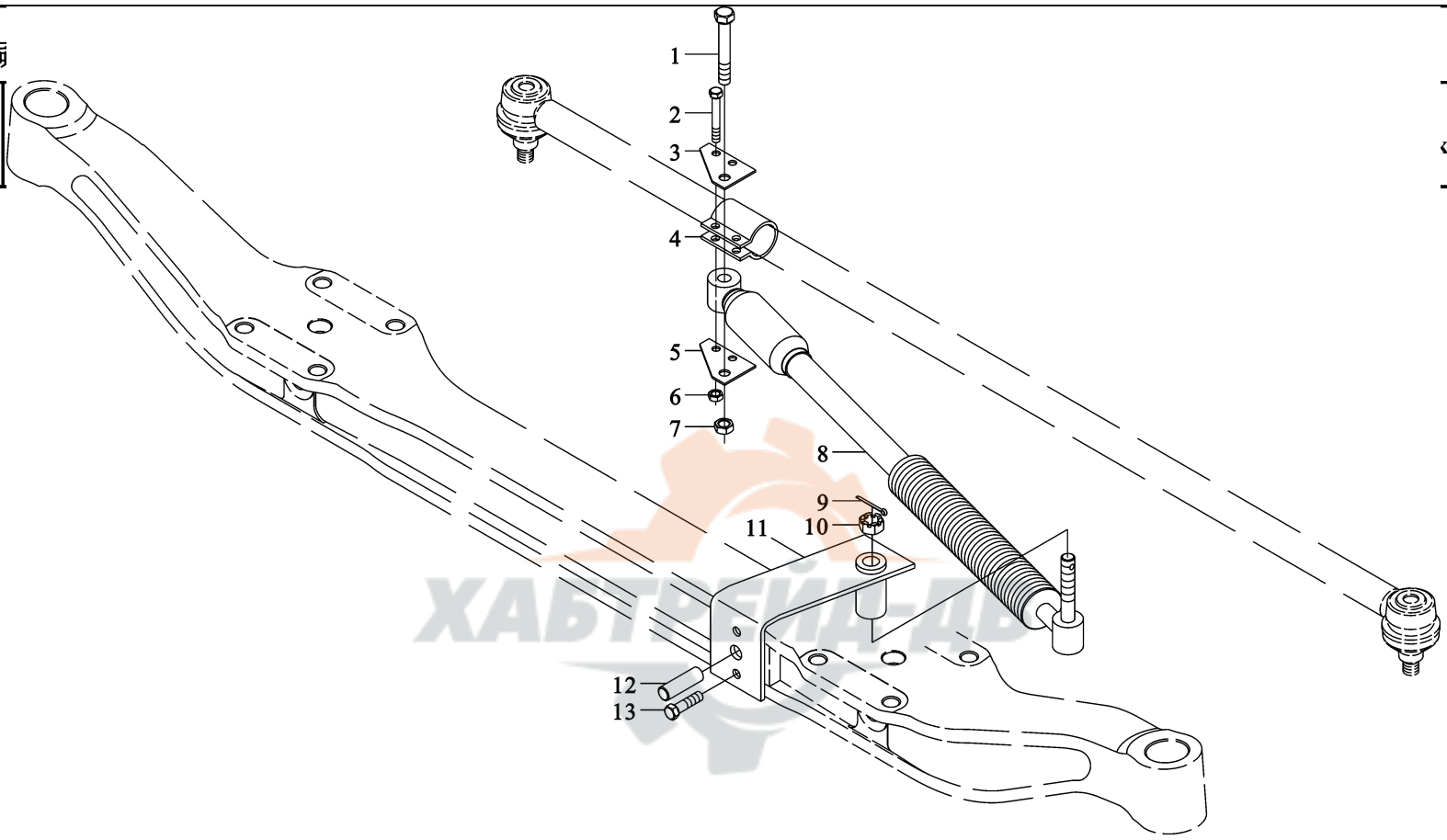

1	Q151B1480	六角□ 螺栓	Hex screw	1		
2	Q151C1270	六角□ 螺栓	Hex screw	2		
3	99118470035	支 板	Plate	1		
4	AZ9118470037	□ □ □ 箍	Clip	1		
5	99118470036	支 板	Plate	1		
6	90003888457	自□ 螺母	Locking nut	2		
7	90003888458	自□ 螺母	Locking nut	1		
8	99114470106	减振器	Shock absor	1		
9	Q5003225	□ □ □	Cotter pin	1		
10	Q381B14	I 型六角□ 槽螺母	Slit nut	1		
11	99118470033	角钢焊接总成	Angle steel welding assy	1		
12	Q5211424	园柱□	Cyl pin	1		
13	Q151B1025	六角□ 螺栓	Hex screw	2		

上 推 力 杆      UPPER PUSH ROD

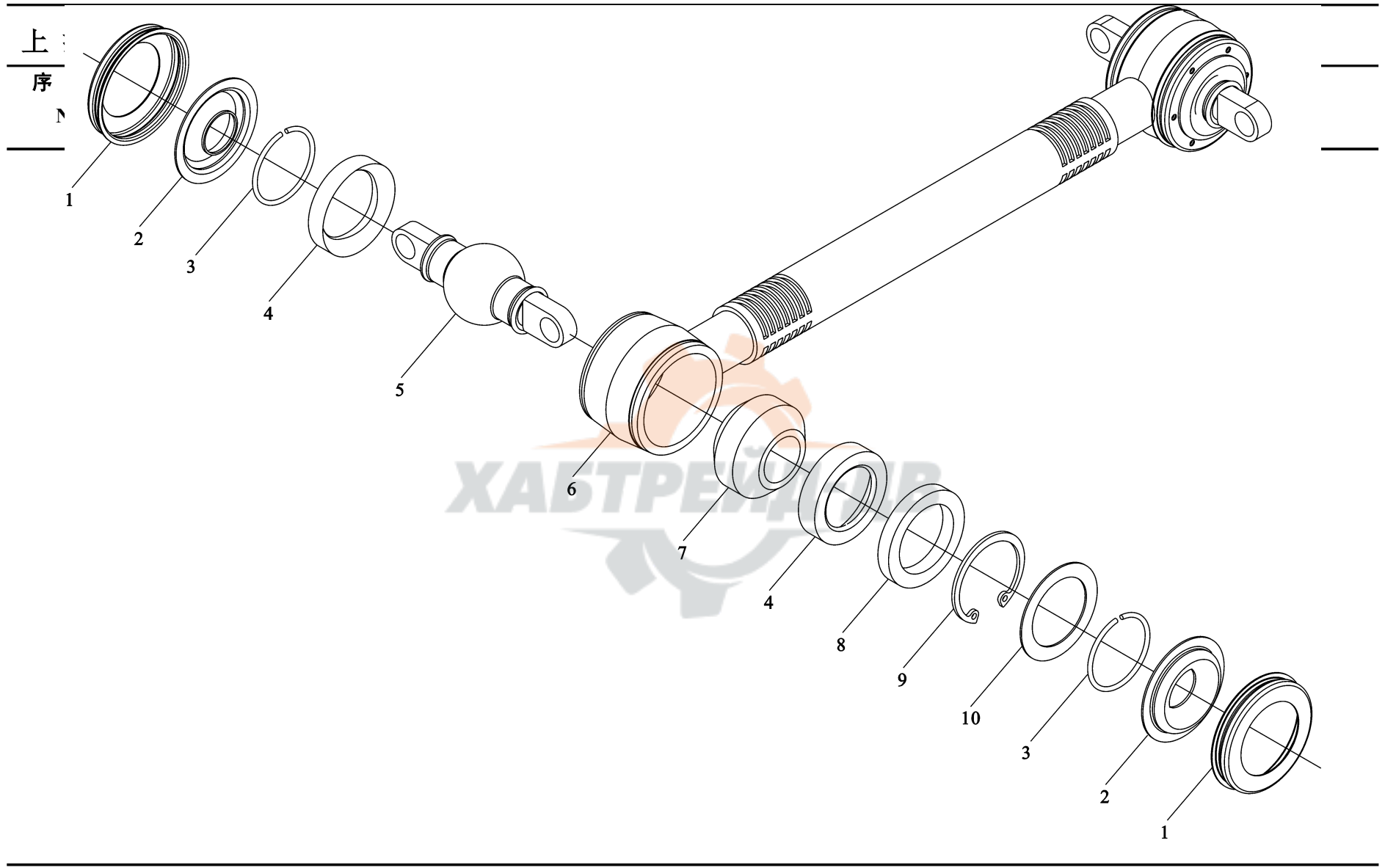

	99014520174	上推力杆□ 戚	Upper push rod assy	1		
	99014520865	□ 用□ 戚	Assy	2		
1	99014520837	固定□	Ring	4		
2	99014520836	密封皮碗	Cup washer	4		
3	99014520838	□ □ □ 圈	Snap ring	4		
4	99014520835	□ □	Ring	4		
5	99014520832	双□ 球□ □	Ball pin	2		
6	88014520174	推力杆	Push rod	1		
7	99014520833	球 座	Ball seat	4		
8	99014520834	□ □ 螺□	Locking ring	2		
9	90003934400	□ 簧□ □	Spring washer	2		
10	99014520839	隔 片	Spacer	2		

下 推 力 杆      LOWER PUSH ROD

下推力

序号
NO

注
mark

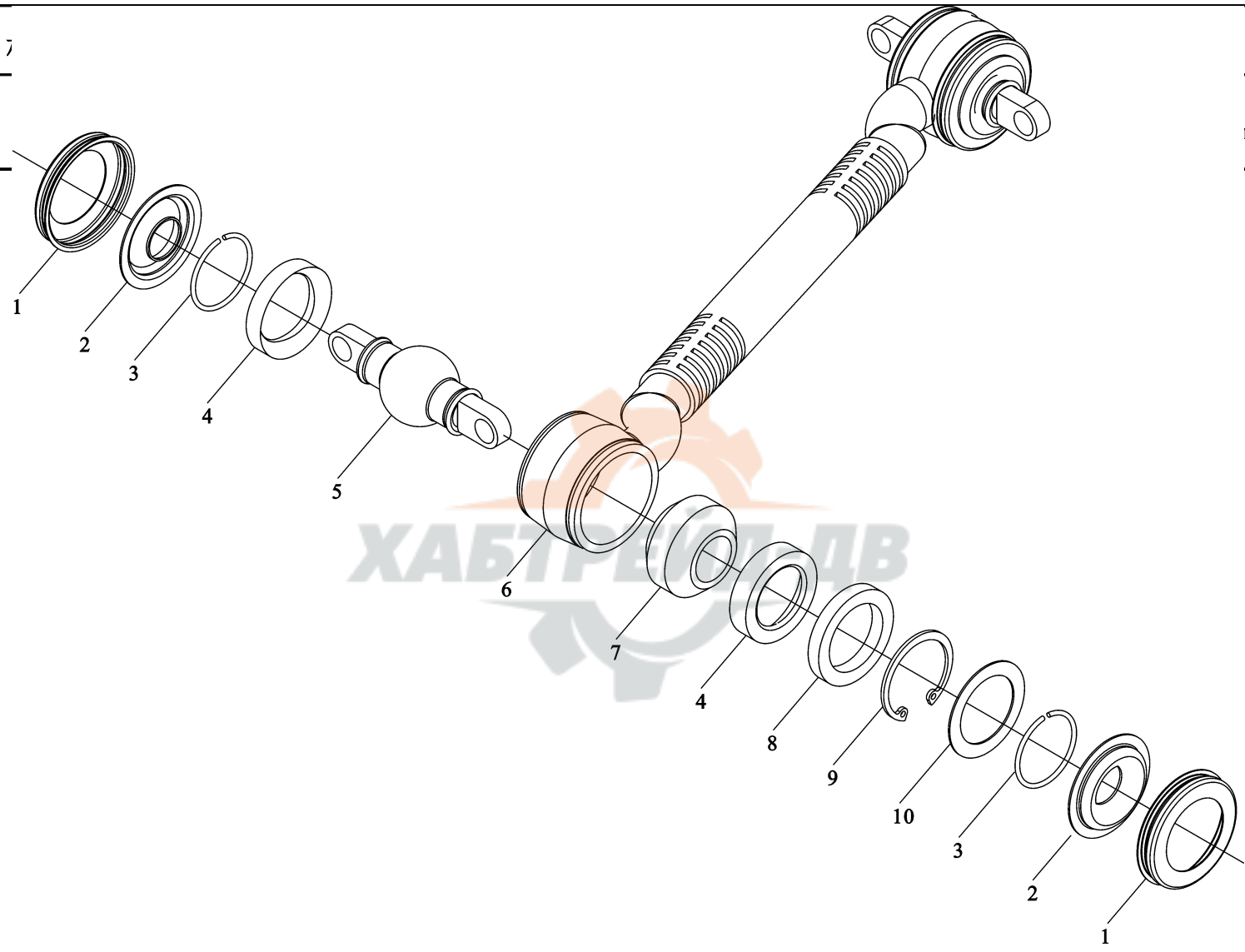

	99014520175	下推力杆 总成	Lower push rod assy			
1	99014520837	固定 圈	Ring	4		
2	99014520837	密封皮碗	Cup washer	4		
3	99014520838	□ □ □ 圈	Snap ring	4		
4	99014520835	□ □	Ring	4		
5	99014520832	双 球 座	Ball pin	2		
6	99014520475	推力杆	Push rod	1		
7	99014520833	球 座	Ball seat	4		
8	99014520834	□ □ 螺 母	Locking ring	2		
9	990003934400	□ 簧 □ □	Spring washer	2		
10	99014520839	隔 片	Spacer	2		

前 钢 板 弹 簧      FRONT LEAF SPRING

# 前钢板弹

序号	件
NO	P

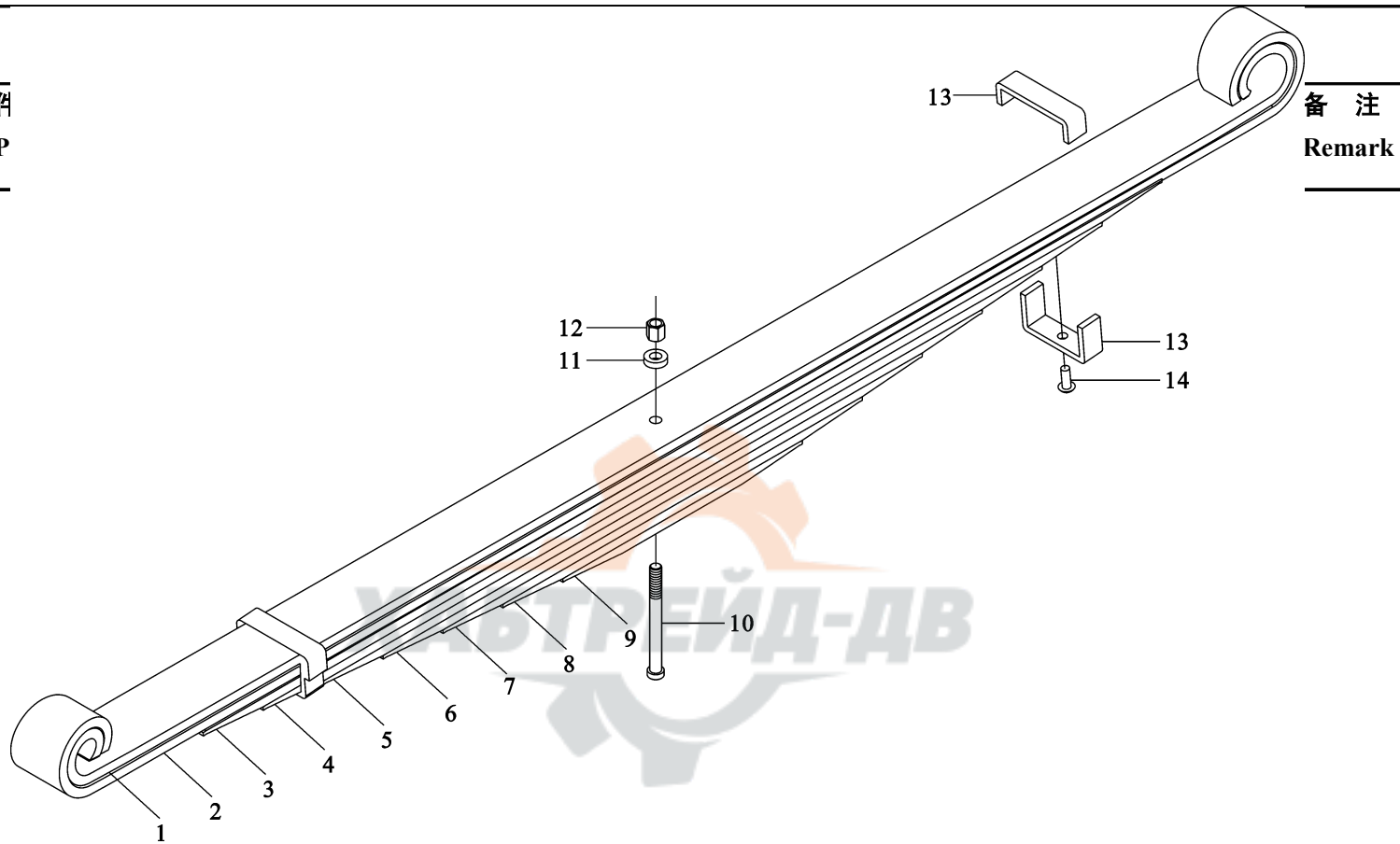

备注  
Remark

	DZ9100529004	右前板簧□ 戚	Front leaf spring (Right)	1	6×4 4×2
	DZ9100529005	左前板簧□ 戚	Front leaf spring (Left)	1	6×4 4×2
	DZ9118529002	左前板簧□ 戚□(12片)	Front leaf spring (Left)	1	8×4
	DZ9118529001	右前板簧□ 戚□(13片)	Front leaf spring (Right)	1	8×4
1	99100520707	□ 簧板 1	Spring plate 1	1	
2	99100520708		Spring plate 2	1	
3	991100520709	□ 簧板 2	Spring plate 3	1	
4	99114520724		Spring plate 4	1	
5	99114520725	□ 簧板 3	Spring plate 5	1	
6	99114520726		Spring plate 6	1	
7	99114520745	□ 簧板 4	Spring plate 7	1	
8	99114520746		Spring plate 8	1	
9	99114520747	□ 簧板 5	Spring plate 9	1	
10	99100520710		Screw	1	
11	680 520798	□ 簧板 6	Washer	1	
12	79000520733		Nut	1	
13	99100520711	□ 簧板 7	Spring clip	2	
14	90003910430		Rivet	2	
		□ 簧板 8			
		□ 簧板 9			
		板簧螺栓			
		□ 圈 □			
		螺 母			

后钢板弹簧 REAR LEAF SPRING



# 后钢板弹

序号	件
NO	P

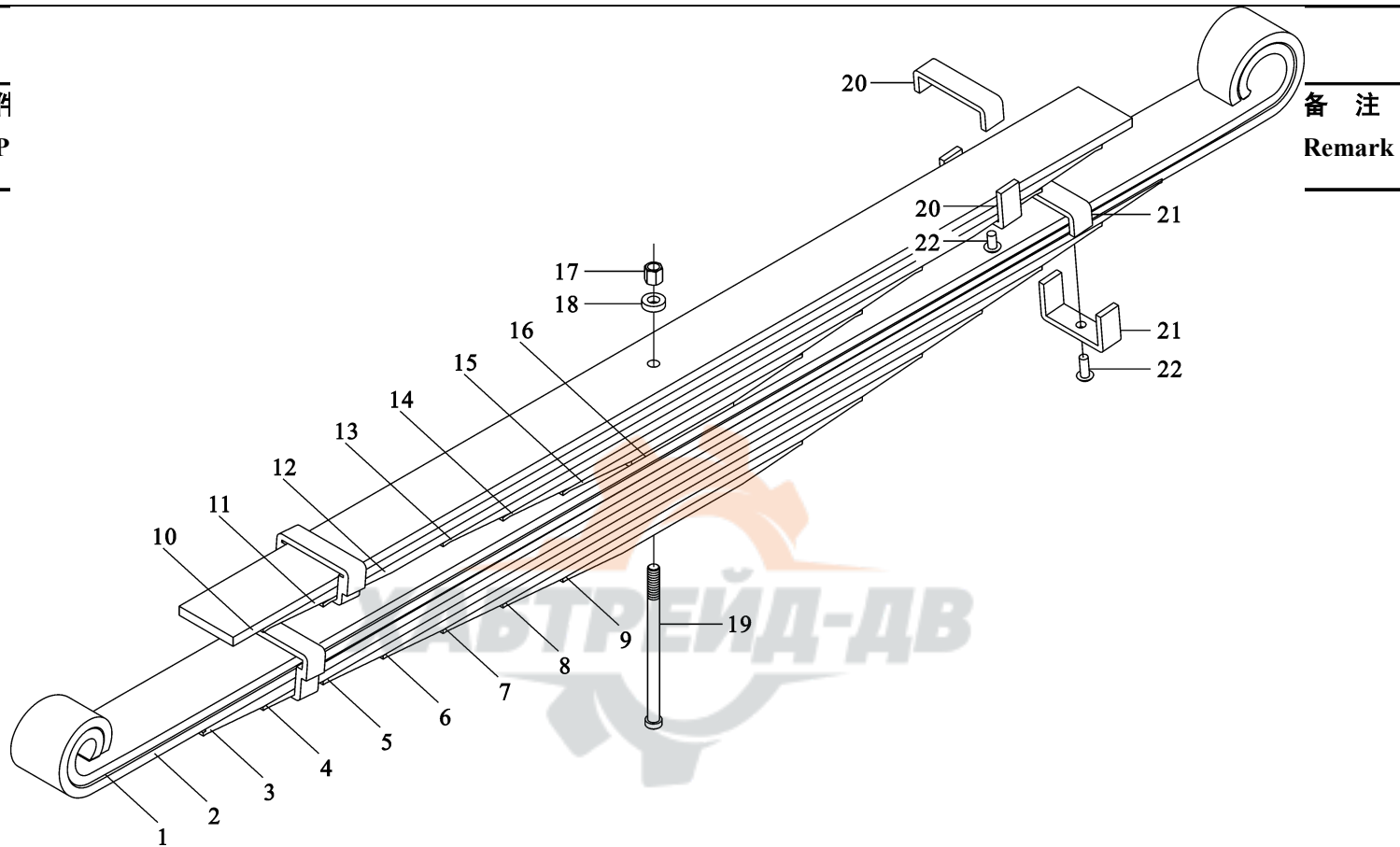

备注  
Remark

	99112520004	后□ 板□ 簧□ 成	Rear leaf spring assy	1		4×2
1	99112520701	□ 簧板 1	Spring plate 1	1		
2	99112520702		Spring plate 2	1		
3	99112520703	□ 簧板 2	Spring plate 3	1		
4	99112520708		Spring plate 4	1		
5	99112520709	□ 簧板 3	Spring plate 5	1		
6	99112520724		Spring plate 6	1		
7	99112520726	□ 簧板 4	Spring plate 7	1		
8	99112520727		Spring plate 8	1		
9	99112520725	□ 簧板 5	Spring plate 9	1		
10	99100520712		Spring plate 10	1		
11	99100520748	□ 簧板 6	Spring plate 11	1		
12	99100520754		Spring plate 12	1		
13	99100520749	□ 簧板 7	Spring plate 13	1		
14	99100520750		Spring plate 14	1		
15	99100520751	□ 簧板 8	Spring plate 15	1		
16	89100520704		Spring plate 16	1		
17	79000520737	□ 簧板 9	Nut	1		
18	680 520796		Washer	1		
19	99112520704	□ 簧板10	Screw	1		
20	99100520717	□ 簧板11	Spring clip	2		
21	99100520714		Spring clip	2		
22	90003910430	□ 簧板12	Rivet	4		
		□ 簧板13				
		□ 簧板14				

钢板弹簧 LEAF SPRING

钢板弹簧 L

序号	件号
NO	Part.No

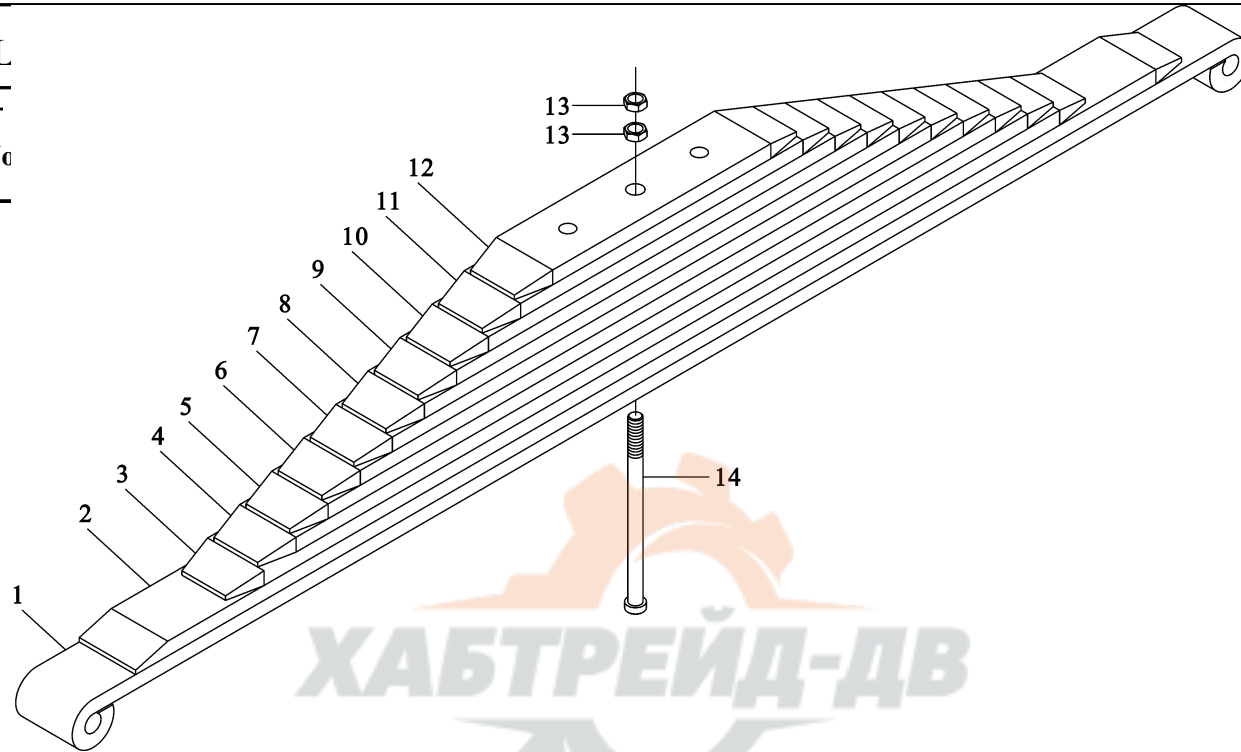

备注  
Remark

	99014520230	□ 板簧总成	Leaf spring assy	1	6×4 8×4	
1	99014520840	□ 簧板 1	Spring plate 1	1		
2	99014520841	□ 簧板 2	Spring plate 2	1		
3	99014520842	□ 簧板 3	Spring plate 3	1		
4	99014520843	□ 簧板 4	Spring plate 4	1		
5	99014520844	□ 簧板 5	Spring plate 5	1		
6	99014520845	□ 簧板 6	Spring plate 6	1		
7	99014520846	□ 簧板 7	Spring plate 7	1		
8	99014520847	□ 簧板 8	Spring plate 8	1		
9	99014520848	□ 簧板 9	Spring plate 9	1		
10	99014520849	□ 簧板 10	Spring plate 10	1		
11	99014520850	□ 簧板 11	Spring plate 11	1		
12		□ 簧板 12	Spring plate 12	1		
13	90003888621	□ 簧板 7	Nut	2		
14	99014520800	□ 簧板 8	Screw	1		
		□ 簧板 9				
		□ 簧板 10				
		□ 簧板 11				
		□ 簧板 12				
		螺 母				
		板簧螺栓				

车 轮 及 轮 胎      WHEEL AND TYRE

车 轮

序 号

NO

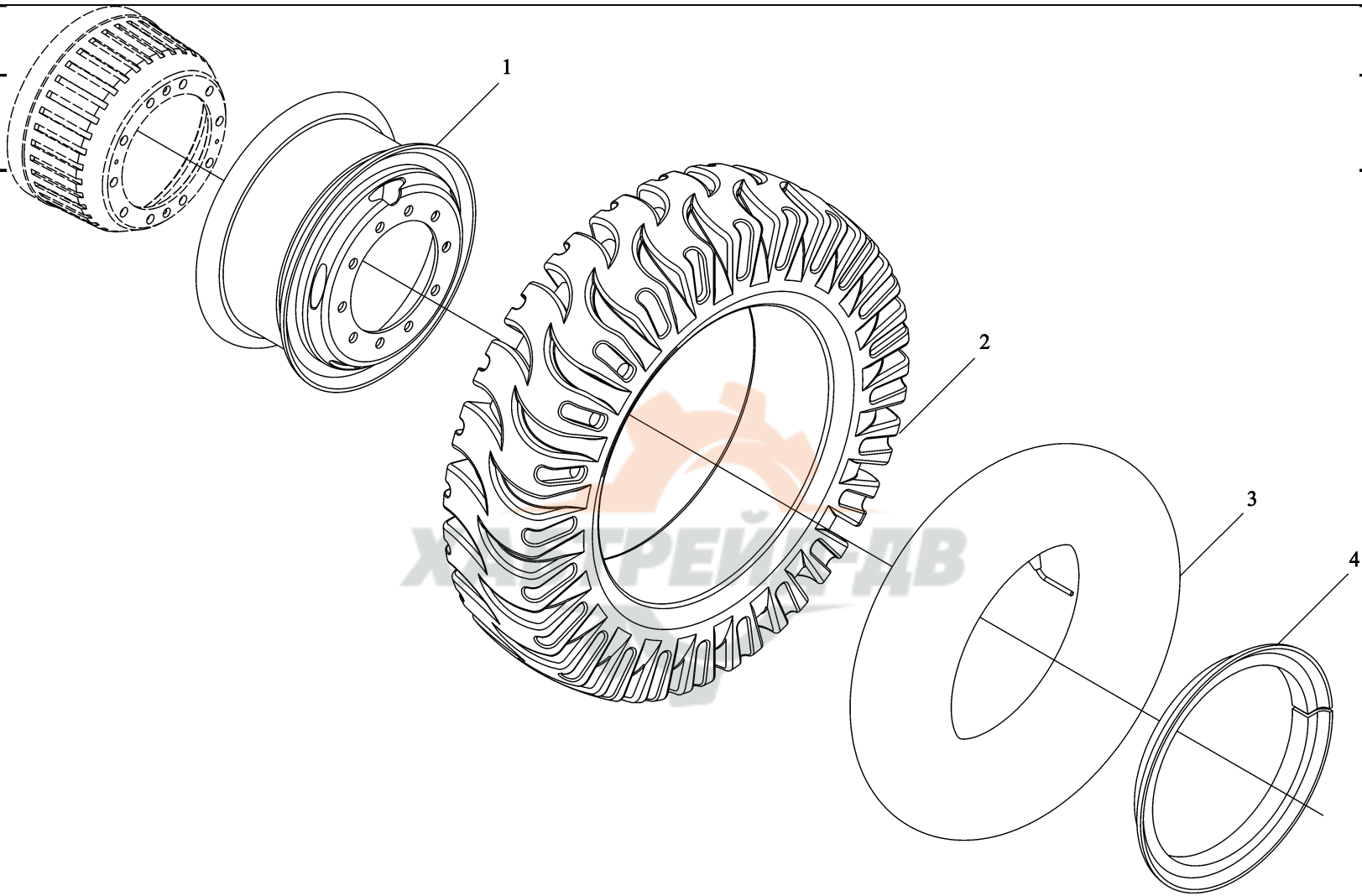

1	DZ9100610061	8.5-20 二件式 □ □ 戚	8.5-20 wheel assy	1		
2	DZ9100610021	12.00R20 □ 胎 ATH 18PR	12.00R20 tyre ATH 18PR	1		
3	DZ9112610032	SEMP	12.00-20 tube assy	1		
4	30066610075	12.00-20 内胎 □ 戚 SEMP 8.5-20 二件式 □ 牲 □ 圈	8.5-20 circlip	1		



备 轮 架 SPARE WHEEL HOLDER

备  
序

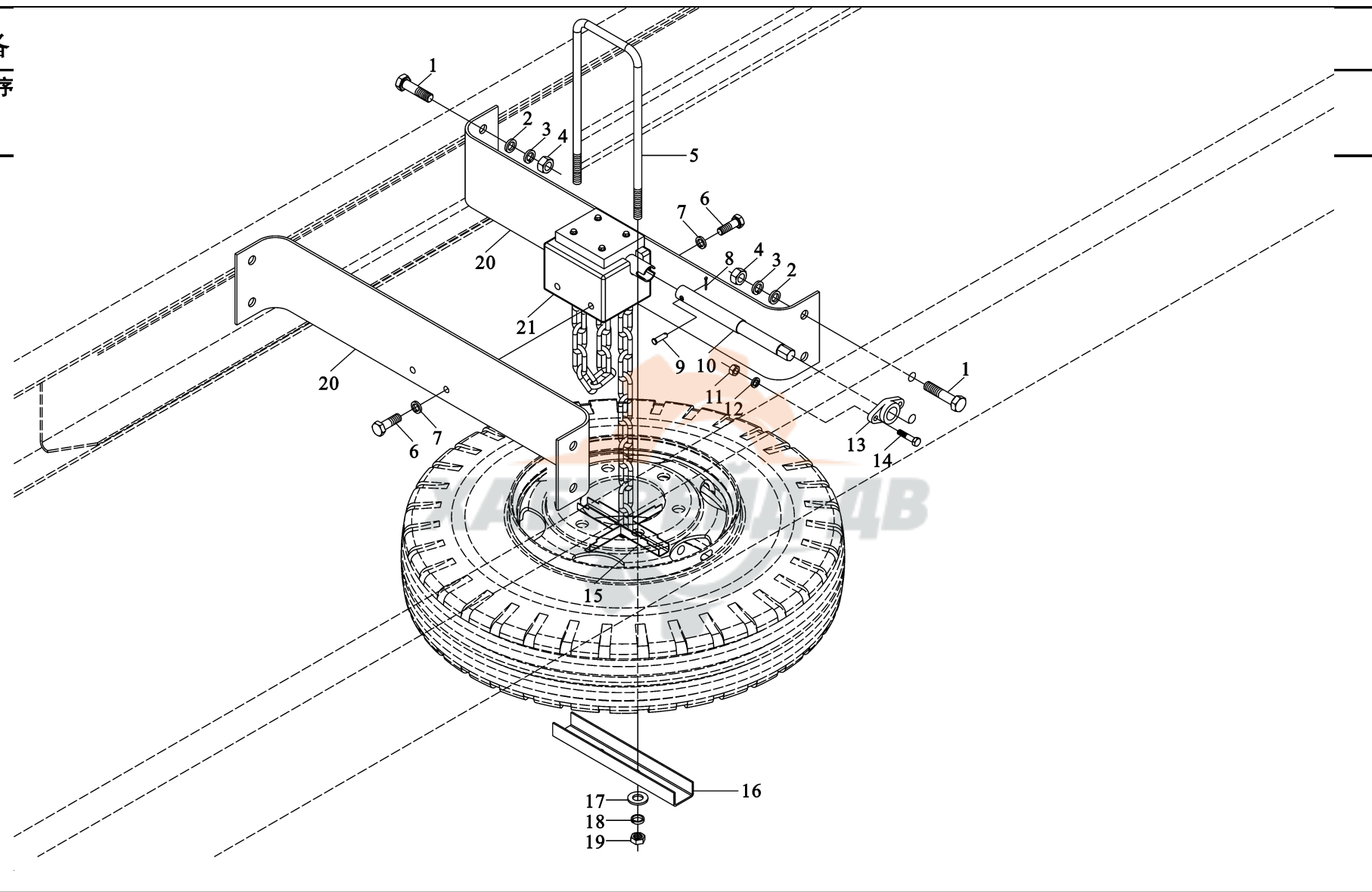

1	Q150B1648	六角□ 螺栓	Hex screw	8		
2	Q40116	平□ 圈	Flat washer	8		
3	Q40316	□ 簧□ 圈	Spring washer	8		
4	Q340B16	I 型六角螺母	Hex nut	8		
5	2190EB-310505	□ □ U型螺栓	Screw	1		
6	5		Hex screw	4		
7	Q150B1225	六角□ 螺栓	Spring washer	4		
8	Q40312	□ 簧□ 圈	Cotter pin	1		
9	Q5003214	□ □ □	Bolt	1		
10	Q5100845	□ □	Shake rod	1		
11	1380A-3105012	□ 杆 □	Hex nut	2		
12	Q340B08	I 型六角螺母	Spring washer	2		
13	Q40308	□ 簧□ 圈	Support block	1		
14	DZ9100862001	□ 杆支承□	Hex screw	2		
15	Q150B0840	六角□ 螺栓	Bracket	1		
16	1380A-3105020	托架□ 成	Support member	1		
17	1380A-3105054	支撑梁	Flat washer	2		
18	Q40114	平□ 圈	Spring washer	2		
19	Q40314	□ 簧□ 圈	Hex nut	2		
20	Q341B14	I 型六角螺母	Cross member	2		
21	DZ9112860081	横 梁	Spare wheel holder body	1		
	DZ9100862040	□ 胎架本体				

液 压 备 轮 架      HYDRAULIC SPARE WHEEL HOLDER



液 压 备

序 号
NO

注  
ark

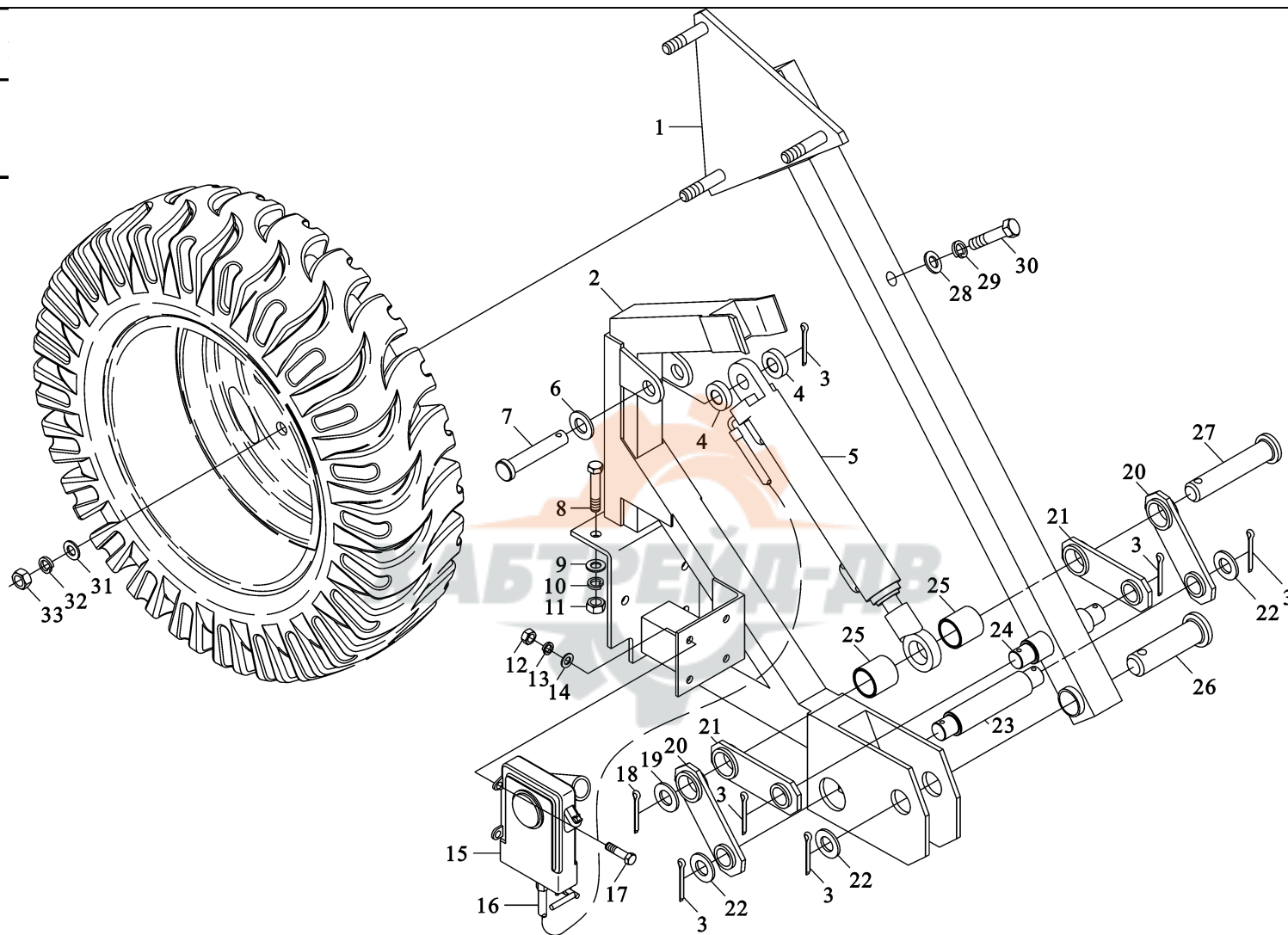

1	DZ9118861020	液压备胎架翻转架总成	Overturn bracket assy	1		
2	DZ9118861100	液压备胎架支架总成	Bracket assy	1		
3	Q5005040	开口销	Cotter pin	6		
4	DZ9118861019	油缸隔套（一）	Cylinder spacer I	1		
5	DZ9118861200	液压油缸总成	Hydraulic cylinder assy	1		
6	Q40124	大垫圈	Washer	1		
7	DZ9118861018	销轴（五）	Bolt	1		
8	Q150B1445	六角头螺栓	Hex screw	5		
9	Q40114	平垫圈	Flat washer	5		
10	Q40314	弹簧垫圈	Spring washer	5		
11	Q340B14	I 型六角螺母	Hex nut	5		
12	Q340B12	I 型六角螺母	Hex nut	4		
13	Q40312	弹簧垫圈	Spring washer	4		
14	Q40112	平垫圈	Flat washer	4		
15	DZ9100820026	液压手动油泵	Hydraulic handle pump	1		
16	DZ9118861210	高压软管总成	High pressure hose assy	1		
17	Q150B1240	六角头螺栓	Hex screw	4		
18	Q5005050	开口销	Cotter pin	1		
19	DZ9118861056	挡圈（二）	Circlip II	1		
20	DZ9118861060	连板总成	Connecting plate assy	2		
21	DZ9118861050	连板总成	Connecting plate assy	2		
22	DZ9118861054	挡圈（三）	Circlip III	5		
23	DZ9118861058	轴（一）	Shaft I	1		
24	DZ9118860024	轴（三）	Shaft III	1		
25	DZ9118861057	油缸隔套（二）	Spacer II	2		

液 压 备 轮 架      HYDRAULIC SPARE WHEEL HOLDER

液 压 备

序 号
NO

注  
ark

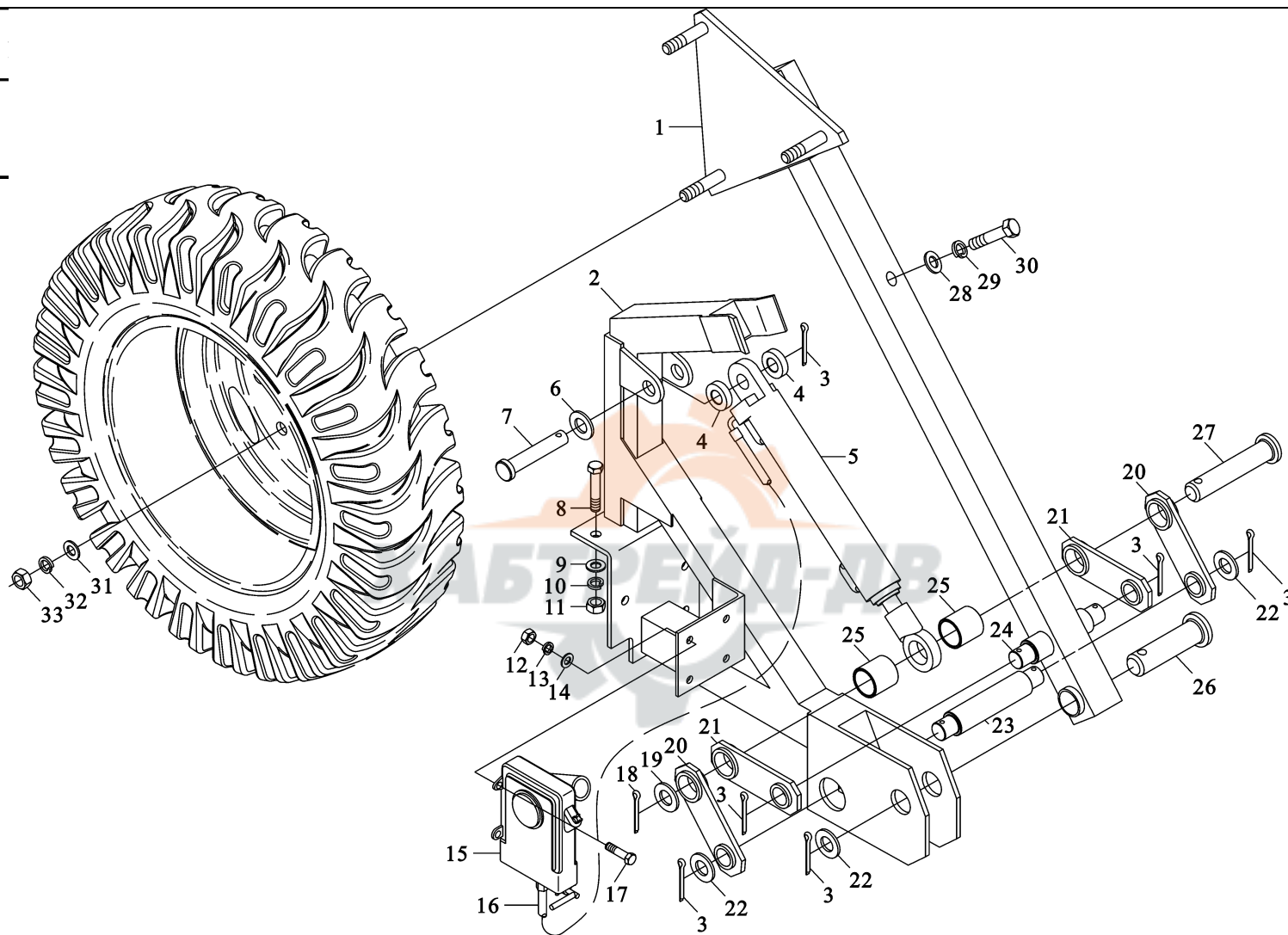

26	DZ9118861052	轴（四）	Shaft IV	1		
27	DZ9118861055	轴（二）	Shaft II	1		
28	Q40116	平垫圈	Flat washer	1		
29	Q40316	弹簧垫圈	Spring washer	1		
30	Q150B16100	六角头螺栓	Hex screw	1		
31	DZ9118861026	垫圈	Washer	3		
32	Q40320	弹簧垫圈	Spring washer	3		
33	Q341B20	I 型六角螺母	Hex nut	3		

高顶驾驶室总成      HIGH ROOF CAB ASSY

高顶驾驶室总成      HIGH ROOF CAB ASSY

序号 NO	件号 Part.No	名称 Designation	Name	数量 Quantit	适用车型 Suited type	备注 Remark
----------	---------------	-------------------	------	---------------	---------------------	--------------



DH0163.430101	豪华型加长加宽高顶驾驶室	Luxury lengthend widen high roof cab	1		(带天窗) with clearstory
DH0163.430201	基本型加长加宽高顶驾驶室	standard lengthend widen high roof cab	1		
DH0163.430199	豪华型右置加长加宽高顶驾驶室	Luxury lengthend widen high roof cab right	1		(带天窗) with clearstory
DH0163.430299	基本型右置加长加宽高顶驾驶室	standard lengthtnd widen high roof cab right	1		

高顶驾驶室焊接总成 HIGH ROOF CAB WELDING ASSY

高顶驾驶室焊接总成      HIGH ROOF CAB WELDING ASSY

序号 NO	件号 Part.No	名称 Designation	Name	数量 Quantity	适用车型 Suited type	备注 Remark
----------	---------------	-------------------	------	----------------	---------------------	--------------



<p>DC0163100020 1</p> <p>DC016310002 02</p>	<p>高□□室本体□成</p> <p>高□□室本体□成</p>	<p>High roof cab body assy</p> <p>High roof cab body assy right</p>	<p>1</p> <p>1</p>		<p>右置车 to right</p>
---	---------------------------------	---	-------------------	--	---------------------



半高顶驾驶室总成      HALF HIGH ROOF CAB ASSY



半高顶驾驶室总成    HALF HIGH ROOF CAB ASSY

序号 NO	件号 Part.No	名称 Designation	Name	数量 Quantit	适用车型 Suited type	备注 Remark
----------	---------------	-------------------	------	---------------	---------------------	--------------



DH0163.420101	豪华型半高顶驾驶室	Luxury half high roof cab	1		带天窗 with clearstory
DH0163.420201	基本型半高顶驾驶室	Standard half high roof cab	1		带天窗 with clearstory

半高顶驾驶室焊接总成      HALF HIGH ROOF CAB WELDING ASSY

半高顶驾驶室焊接总成 HALF HIGH ROOF CAB WELDING ASSY

序号 NO	件号 Part.No	名称 Designation	Name	数量 Quantity	适用车型 Suited type	备注 Remark
----------	---------------	-------------------	------	----------------	---------------------	--------------



1	DC0163100010 1	加加型半高□□ 室本体	Lengthend widen half high roof cab	1		
---	-------------------	----------------	---------------------------------------	---	--	--



驾驶室本体 CAB NOUMENON

驾驶室本体 CAB NOUMENON

序号 NO	件号 Part.No	名称 Designation	Name	数量 Quantit	适用车型 Suited type	备注 Remark
----------	---------------	-------------------	------	---------------	---------------------	--------------



1	81.62910.4193	半高□□□室盖总成	Half high roof cab cover assy	1		
2	81.62910.4234	高□□渡□盖□成	High roof transition cover	1		
3	82.62811.5005	地板□成	assy	1		
4	81.62410.5106	前□□成	Floor assy	1		高□□□室 high roof cab
	81.62410.5100	前□□成	Front panel assy	1		
5	81.61420.4087	□表板支架□成	Front panel assy	1		半高□□□室 half high roof
6	81.62510.4503	左□□□成	Dash bard bracket assy	1		cab
	81.62510.4488	右□□□成	Left side panel assy	1		
	81.62510.4500	右□□□成	Right side panel assy	1		
7	81.62710.4235	后□□成	Right side panel assy	1		
8	81.62600.4077	左□□□成	Rear panel assy	1		高□□□室 high roof cab
	81.62600.4082	右□□□成	Left door assy	1		半高□□□室 half high roof cab
			right door assy			

高顶驾驶室顶盖总成 HIGH ROOF CAB COVER ASSY

高  
序  
N

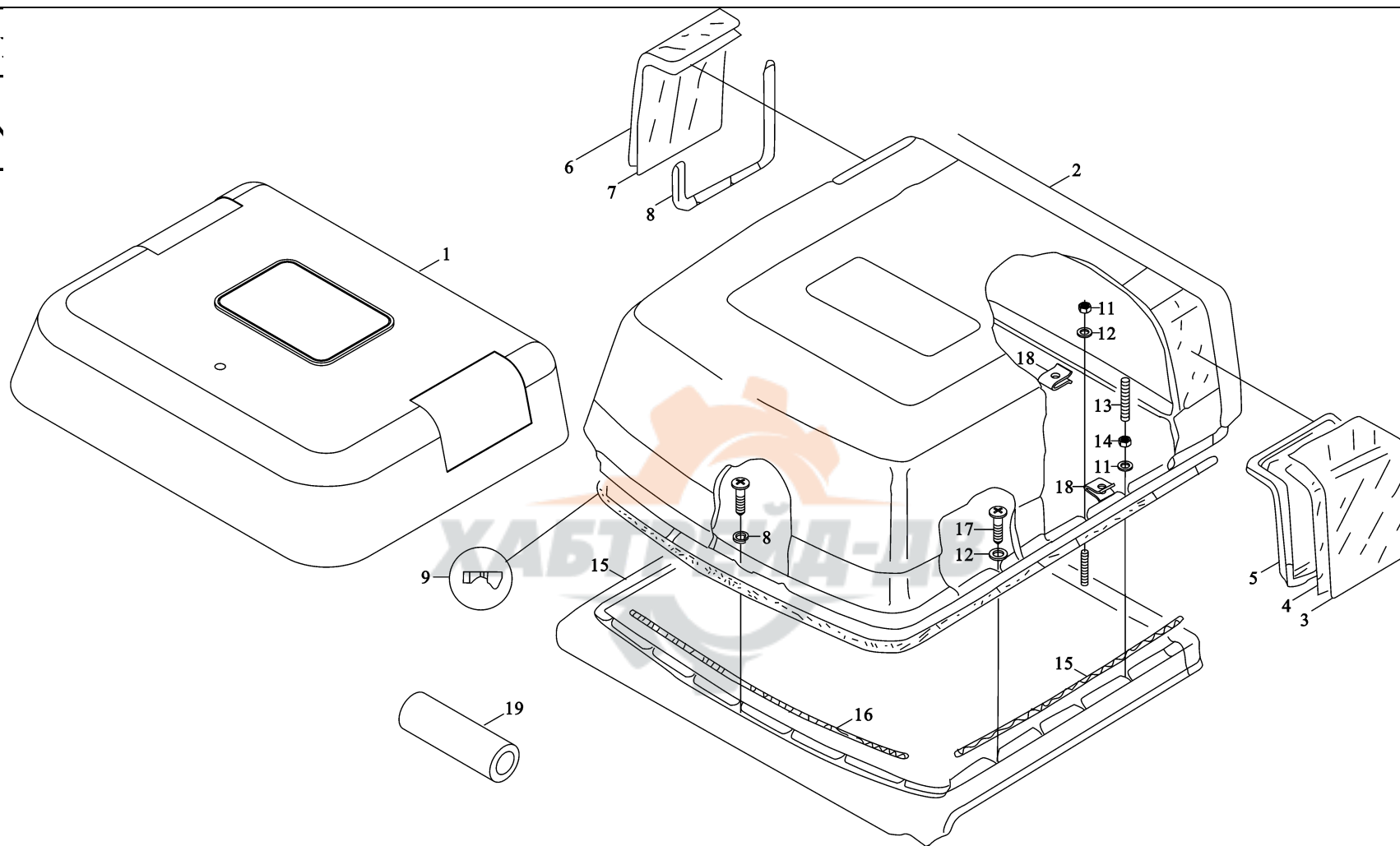

1	81.62900.6188	高□□□室□盖□成	High roof cab cover assy	1	豪华型 luxury	带天窗 with clearstory
	DZ1643930030	高□□□室□盖□成	High roof cab cover assy	1	普通型	不带天窗 without clearstory
2	81.62900.6112	□盖□	Cover	1	stardard	F90
3	81.62944.2001	□窗□	Side glass	1		Left ,outer
4	81.62944.2003	□窗□	Side glass	1		Left,inner
5	81.62930.0055	窗 框	Window frame	1		Left
6	81.62944.2000	□窗□	Side glass	1		Right,outer
7	81.62944.2002	□窗□	Side glass	1		Right,inner
8	81.62930.0056	窗 框	Window frame	1		Right
9	04.29300.0982	密封条	Sealing strip	NB		150000
10	06.18042.0101	方垫片	Square washer	8		9-ST-A3C
11	06.11069.0157	六角螺母	Hex collar nut	8		M8-8SC-8-SW13-MAN183-
12	06.15190.0309	垫 片	Washer	18		B1
13	06.21213.2718	双头螺柱	Threaded pin	2		8,4×24×2-140HV-MAN183-B1
14	06.11184.0164	六角螺母	Hexagon nut	2		BM8×60-6,,8
15	04.93300.9210	胶 带	Adhesive tape round	NB		M8LH-8-A2C
16	04.93300.9028	胶 带	Adhesive tape round	NB		6×78000-GR
17	06.01289.0297	螺 栓	Hex bolt	16		8×60000-GR
	06.01289.0224	螺 栓	Hex bolt	16		M8×25SC-8.8-MAN183-B1
18	81.62910.0087	簧片螺母	Clamp	26		M8×35SC-8.8-MAN183-A2C
19	04.93315.0001	顶盖密封胶	Fabric panelling	NB		7×1300×60000

电 动 天 窗      ELECTRIC CLEARSTORY



电 动  
序 号  
NO

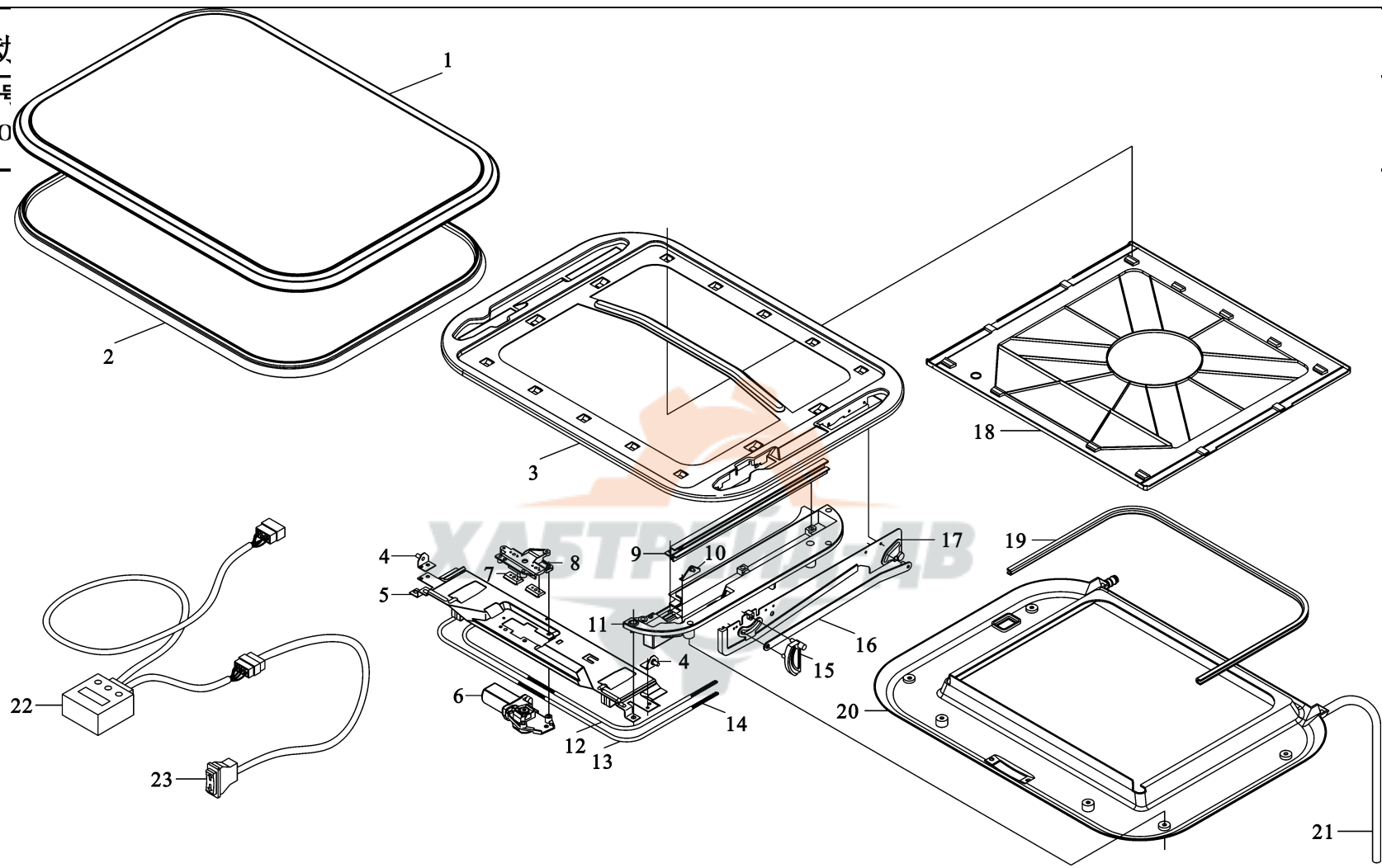

1	OSTM- DDTC-001	外 板	Outer plate	1		
2		密封胶条	Seal strap	1		
3	OSTM-	内 板	Inner plate	1		
4	DDTC-003	滑□□□	Rivet	2		
5	OSTM-	□ 机支撑横梁	Eross member	1		
6	DDTC-002	□ 机 □	Electromotor	1		
7	OSTM-	□ 条□□	Block	2		
8	DDTC-014	□ 机支座	Base	1		
9	OSTM-	副支撑	Support	1		
10	DDTC-023	□ □ □ □	Pin	2		
11	OSTM-	塑料支座 (左)	Plastic seat (left)	1		
	DDTC-029	塑料支座 (右)	Plastic seat (right)	1		
12	OSTM-	塑料□管	Plastic hose	2		
13	DDTC-024	□ □ 管 (左)	Cuprum guided pipe (left)	1		
	OSTM-	□ □ 管 (右)	Cuprum guided pipe (right)	1		
14	DDTC-028	□ 条 □	Rack	2		
15	OSTM-	□ □ □ (左)	Locking block (left)	1		
	DDTC-018	□ □ □ (右)	Locking block (right)	1		
16	OSTM-	□ 杆 (左) □ □	Connecting rod (left)	1		
	DDTC-015	□ 杆 (右) □ □	Connecting rod (right)	1		
17	OSTM-	滑 □ (左)	Slide rail left	1		
	DDTC-016	滑 □ (右)	Slide rail right	1		
18	OSTM-	内□板	Inner decoration	1		
19	DDTC-017	装□条	Pannelling	1		
20	OSTM-	内□罩	Inner decoration cap	1		

电 动 天 窗      ELECTRIC CLEARSTORY

电 动  
序 号  
NO

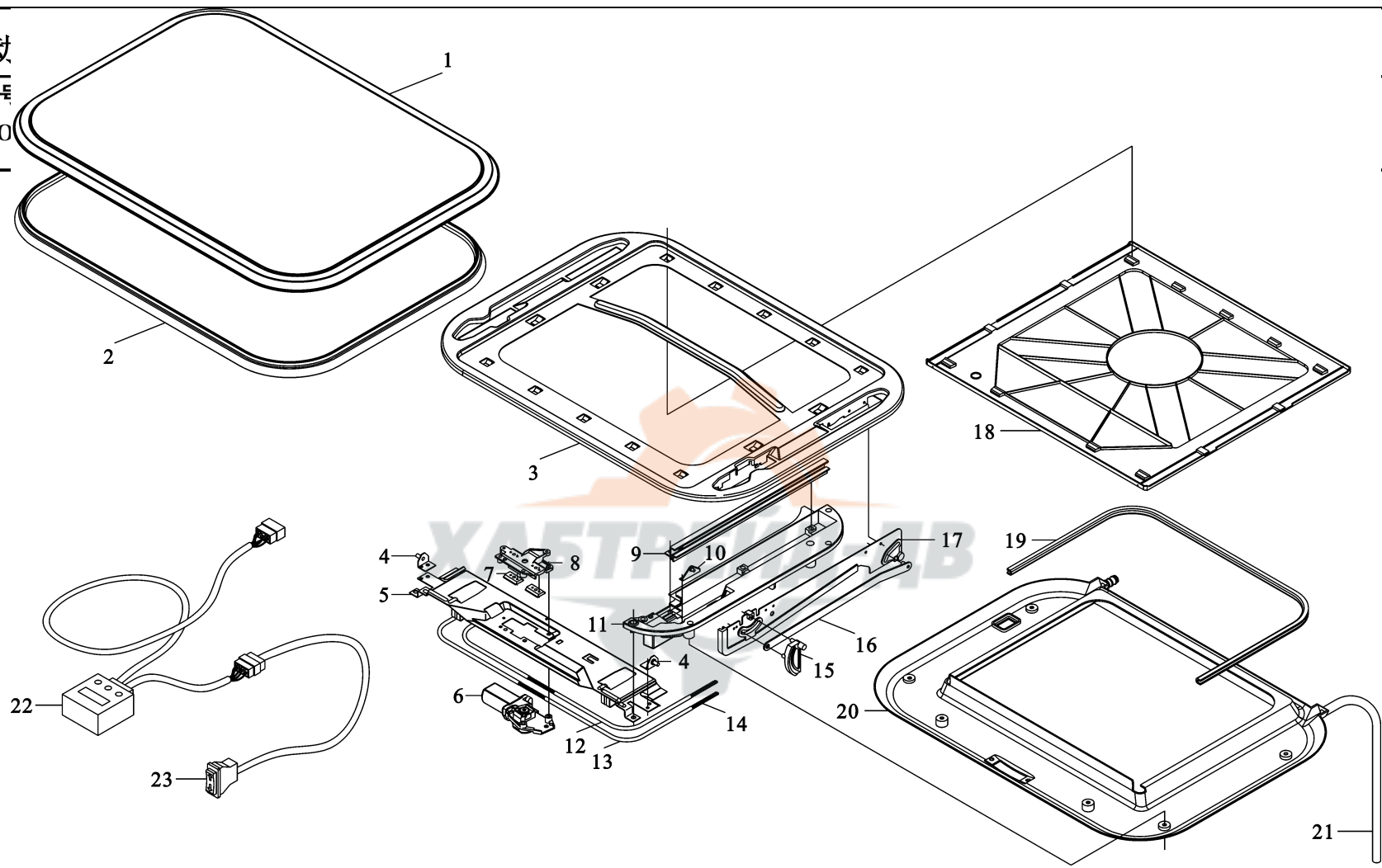

21	OSTM- DDTC-034	排水管	Drain pipe	2		
22		电控盒	Electric box	1		
23	OSTM- DDTC-037 OSTM- DDTC-033	控制开关	Control switch	1		



可视顶 带顶盖 ROOF FOR VERSION WITH ROOF COVER

可视顶带

序号	件号
NO	Part.N

备注  
Remark

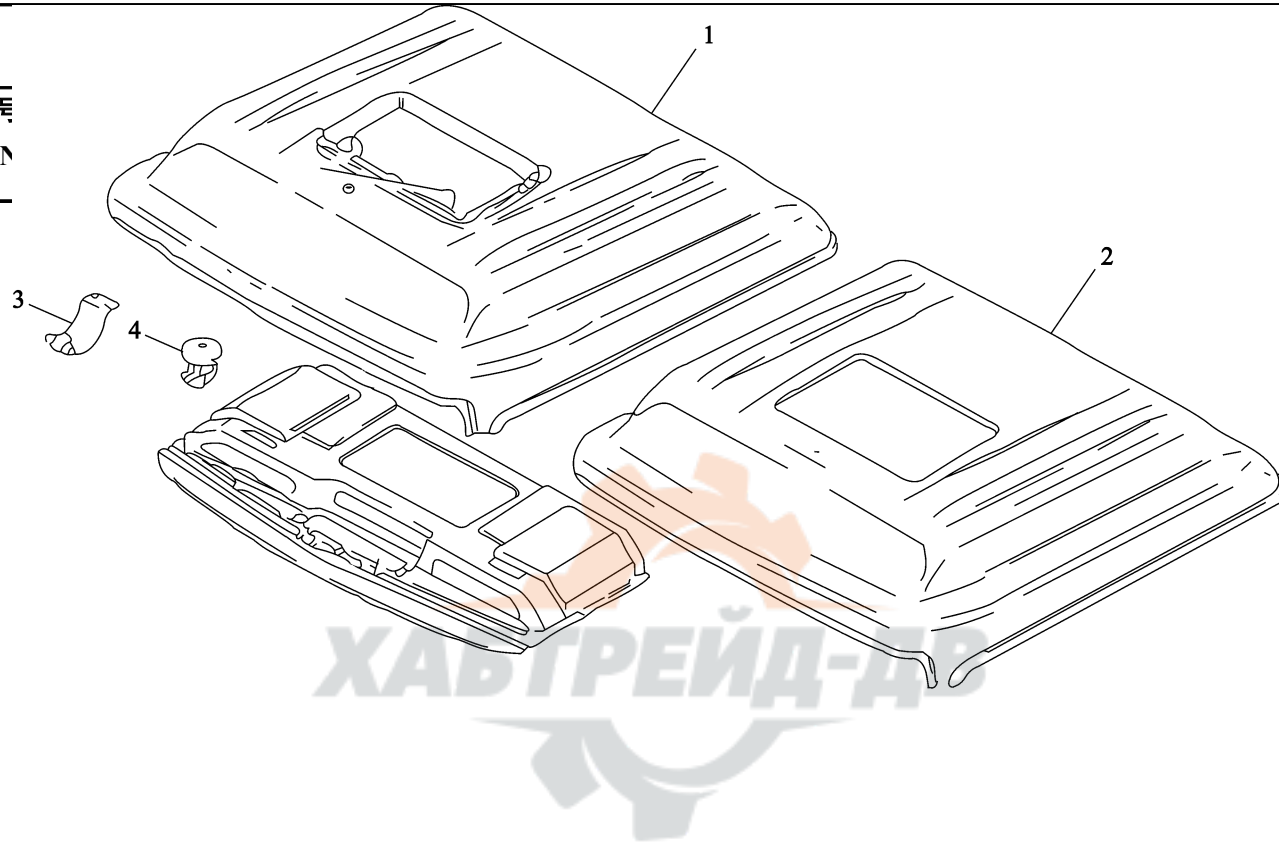

1	81.62910.4193	顶盖总成	Roof assembly	1		
2	81.62910.2368	顶盖外板	Roof skin	1		
3	81.97201.2210	铰链	Hinge	2		
4	81.96410.6004	天线堵塞	Protective capassembly	1		

车顶通风装置 ROOF VENT

车顶通

序号  
NO

k

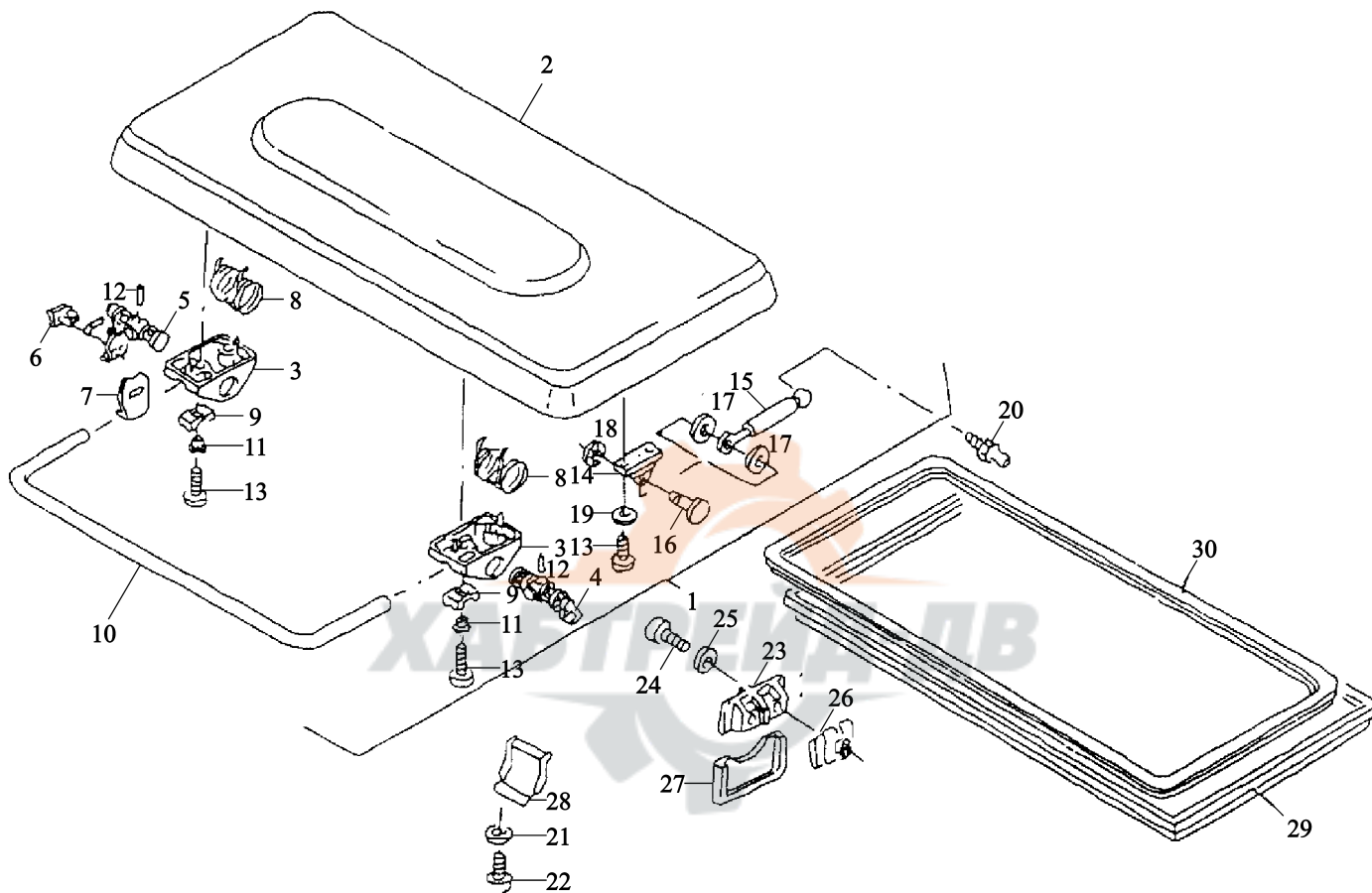

1	81.62941.6038	通风装置总成	Roof vent assembly	1	
2	81.62941.0059	天 窗	Roof vent	1	
3	81.62941.0060	壳 体	Housing	2	
4	81.62941.0061	锁紧垫圈 I	Lock washer i	1	
5	81.62941.0062	锁紧垫圈 II	Lock washer ii	1	
6	81.62941.0055	锁紧件	Detent	1	
7	81.62941.0054	盖	Covering	1	
8	81.62941.0063	弹 簧	Spring	2	
9	81.62941.0064	橡胶挡块	Rubber stop	2	
10	81.62941.0065	支 架	Bracket	1	
11	81.91701.0455	衬 套	Bush	4	6.5×8.8×14/5.5×4.3-GD- ZNAL4CU1
12	06.2220.1014	螺旋定位销	Spiral dowel pin	2	5×28-ST
13	81.90470.0602	开槽自攻螺钉	Grooved oval head screw	8	DURO-PR6*16SB-WN1742-ST- A3C
14	81.62941.0042	支 架	Bracket	2	
15	81.74821.0132	气压弹簧	Gas spring	2	
16	06.21565.0405	销 子	Pin	2	
17	06.15019.0018	垫 片	Washer	4	A6F8×14-CQ15K-A3C
18	06.16119.0020	锁紧垫圈	Lock washer	2	A6.4×12×1.6-PA6.6
19	06.15190.0207	垫 片	Washer	4	6-16-FST
20	81.95302.0064	球头销	Ball pin	2	6.4×18×1.6-140HV-MAN183-B1
21	06.15190.0207	垫 片	Washer	4	C10-M8×13-19MN-SW13-A3C
22	81.90470.0603	带槽的椭圆头螺钉	Grooved oval head screw	4	6.4×18×1.6-140HV-MAN183-B1 DURO-PT6×18SB-WN1742- ST-A3C
23	81.62941.0044	锁紧支架	Locking bracket	2	

车 顶 通 风 装 置 ROOF VENT



车顶通

序号  
NO

k

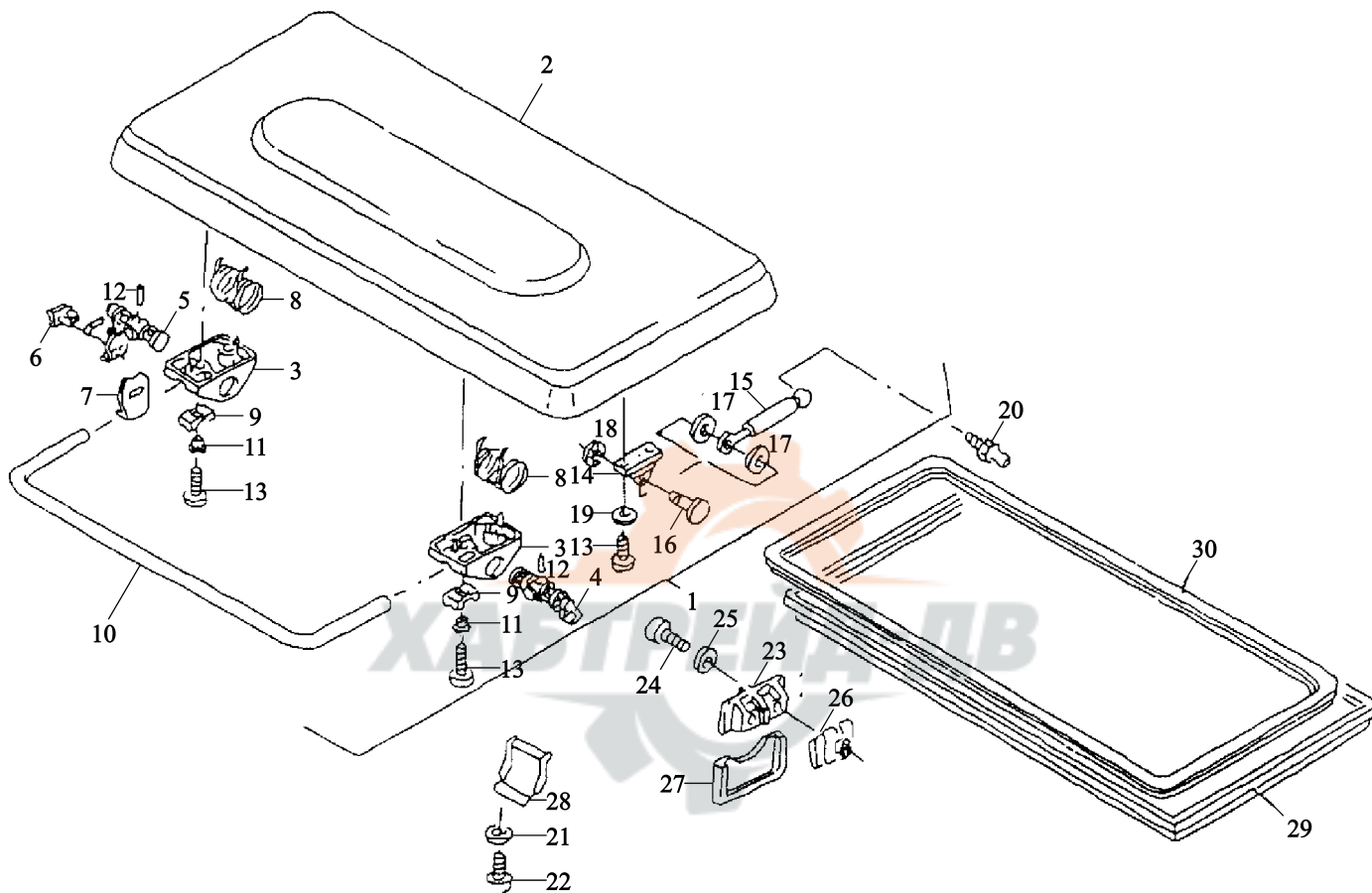

24	06.01283.4919	六角螺栓	Hex screw	4		M6×40
25	06.15191.0207	垫 圈	Washer	4		6.4×18×1.6-140HV-MAN183-B1
26	06.13189.0020	簧片螺母	Slip-on cage nut	4		
27	81.62941.0043	护 盖	Cap	2		
28	81.62930.0032	铰链护盖	Cap	2		
29	81.62930.0025	密封架	Sealing frame roof vent	1		
30	81.96120.0899	天窗密封条	Sealing frame	1		

仪表板镶板 DASHBOARD PANELLING

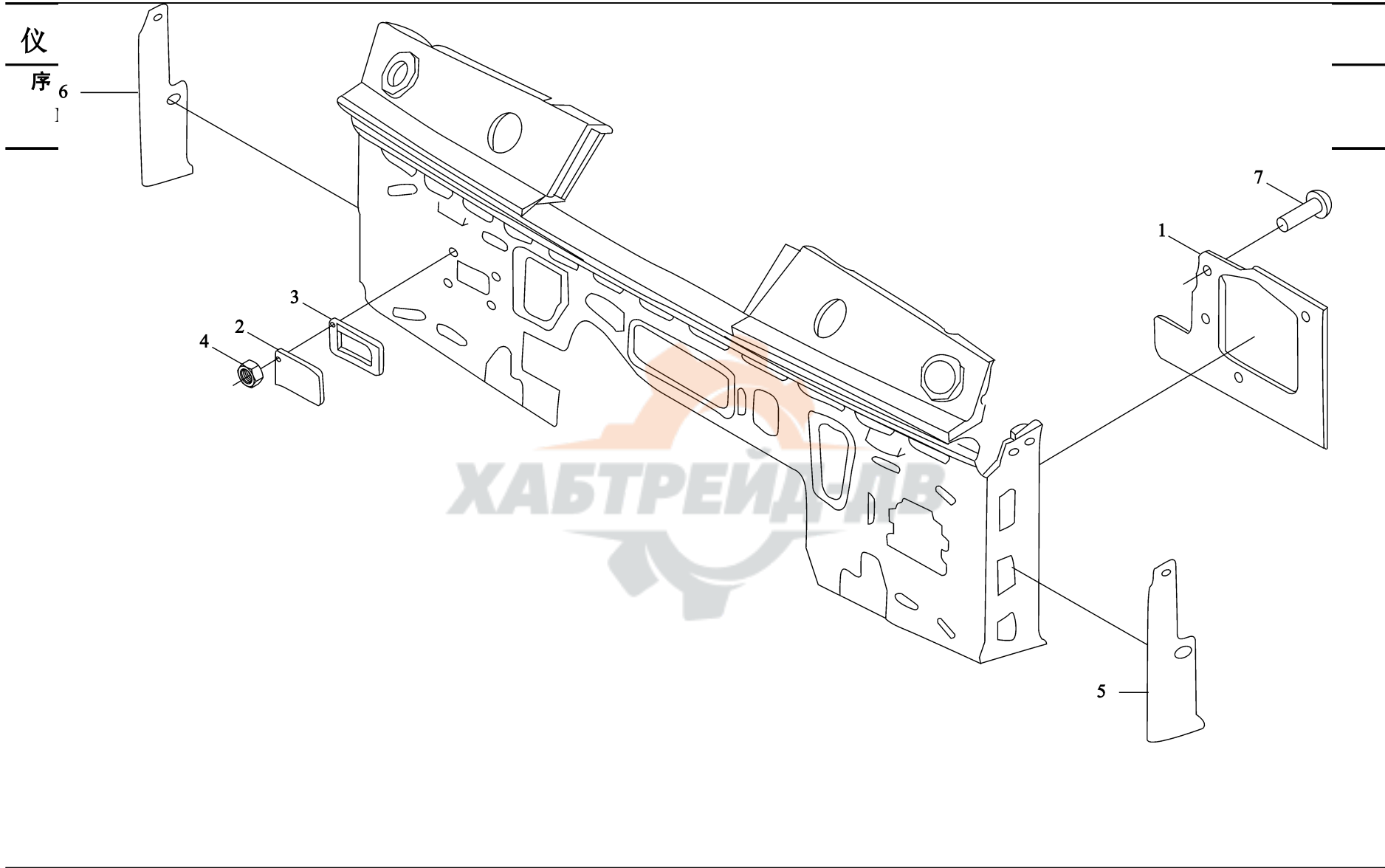

1	81.61470.2159	左前隔音板	Panelling for front panel left	1	
	81.61470.2166	右前隔音板	Panelling for front panel right	1	右置车
2	81.61446.0019	盖 板	Cover	1	
3	81.96601.0415	垫	Gasket asbestos-free	1	
4	06.11069.0156	六角螺母	Washer	4	M6-6SC-8-SW10-MAN183-B1
5	81.61470.4005	左前挡板镶板	Panelling for front panel left	1	
6	81.61470.4006	右前挡板镶板	Panelling for front panel right	1	
7	06.24249.0007	铆 钉	Rivet	4	7×3×17.5-4-PA6.6-SW

盖 板 COVERING LOOM

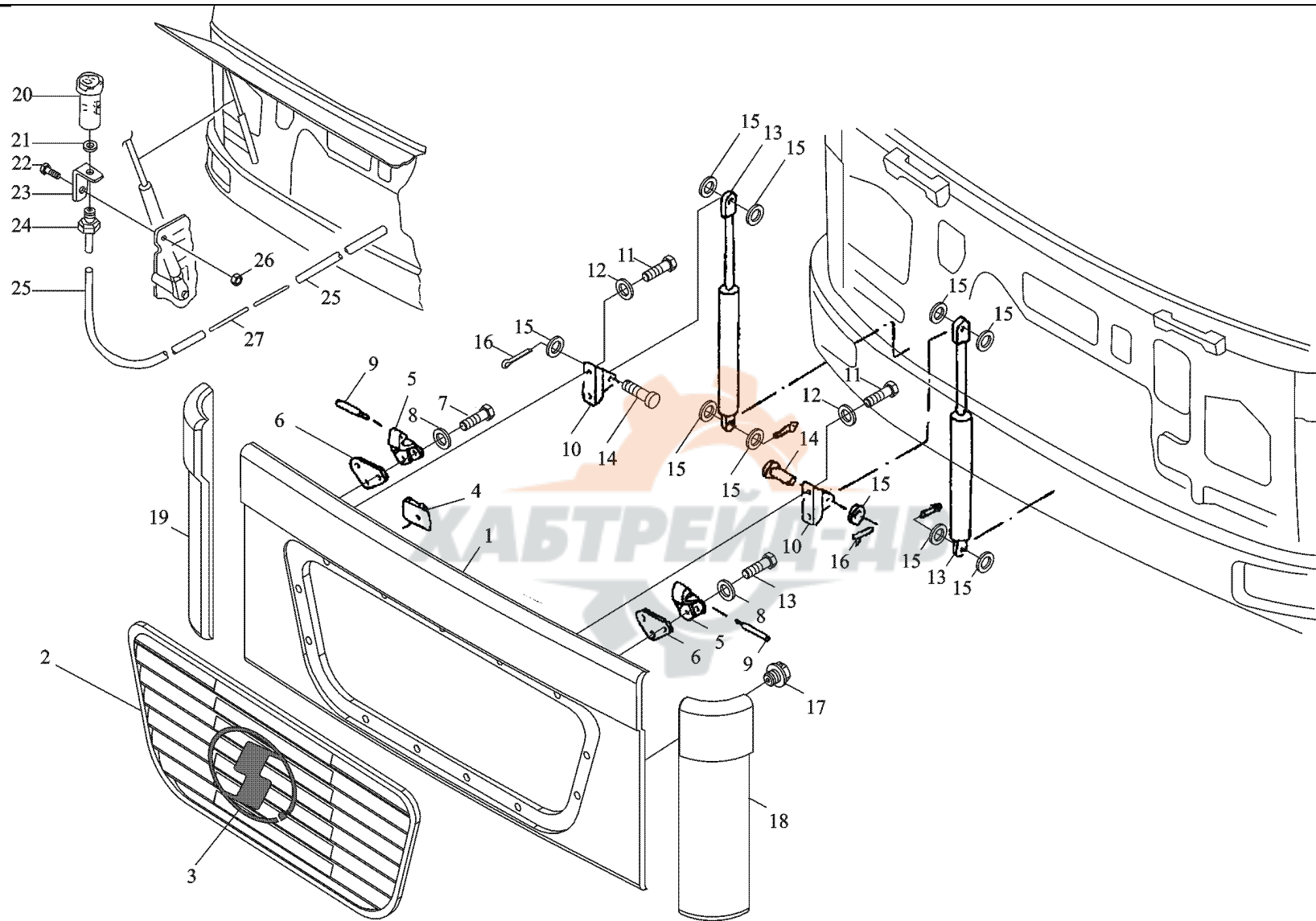

# 盖板 COVERING LOOM

序号 NO	件号 Part.No	名 Design
----------	---------------	-------------

适用车型  
Applied type

备注  
Remark

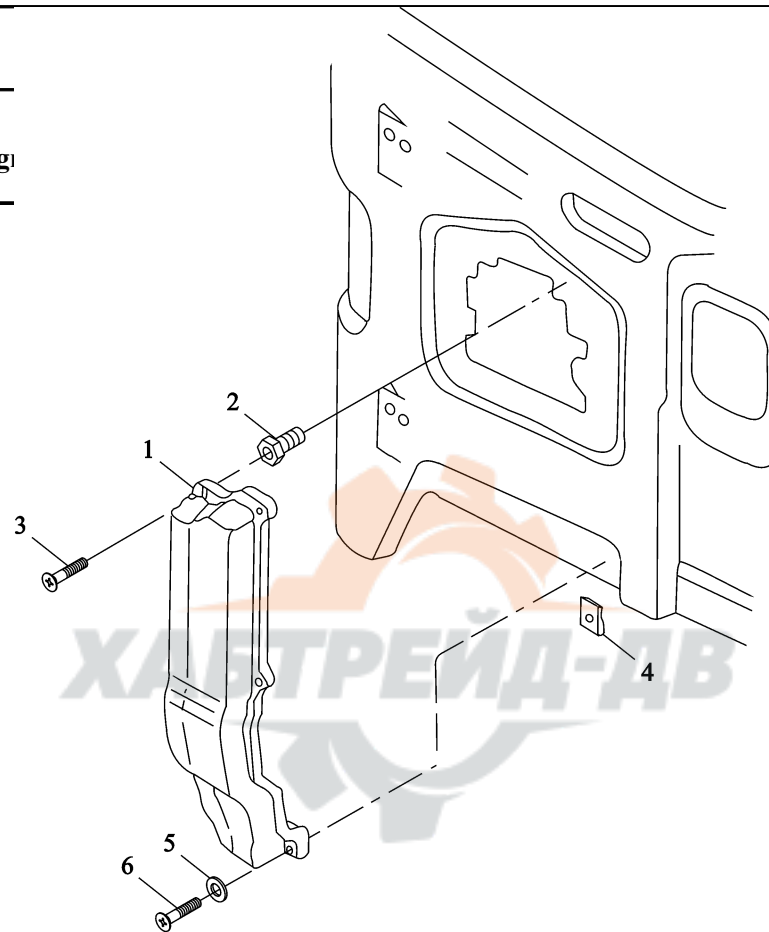

1	81.25425.6002	线束保护罩	Covering assembly	1		
2	81.90685.0377	塑料螺母	Speed nut	4		B4.8-7.0/7.0×8.3-PA6.6-NF
3	06.07154.1506	自攻螺钉	Oval-head self-tapping screw	4		ST4.2×22C-H-H3I
4	06.13189.0108	簧片螺母	speed nut	2		ST4.8-5-MAN183-B1
5	06.15190.0306	垫圈	Speed nut	2		
6	06.07154.1506	自攻螺钉	Washer Oval-head self-tapping screw	2		4.2×22C-H-H3I

前围堵盖 COVER ON FRONT PANEL

前围堵盖 CO

序号 NO	件号 Part.No
----------	---------------

备注 Remark
--------------

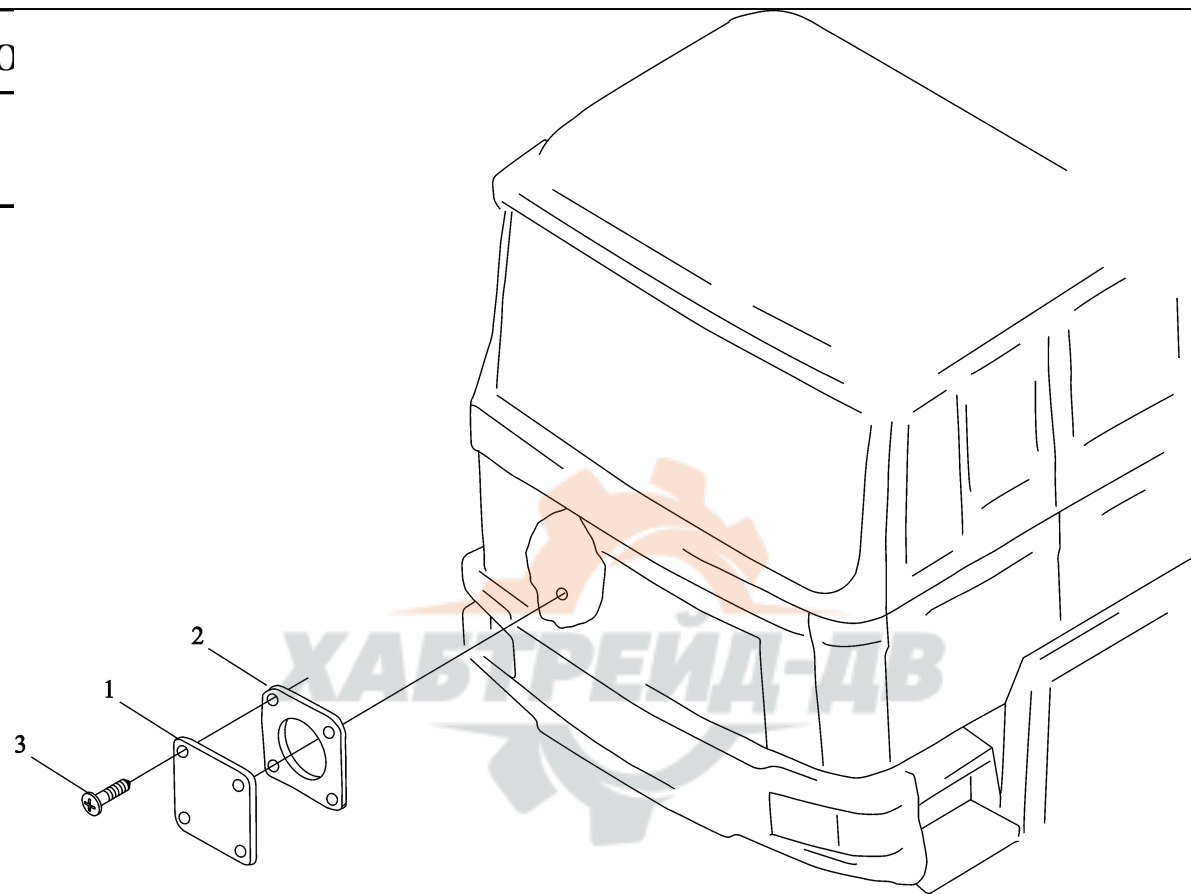



1	81.25425.0023	前围长方形堵盖	Cover on front panel	3		
2	81.96601.0505	石棉垫	Asbestos pad	3		
3	06.07159.0014	圆柱头自攻螺钉	Screw	12		



带有散热器的护栏前面罩及负压报警器  
INDICATOR

RADIATOR GRILLE AND VACUUM







































































































带有散热器的护栏前面罩及负压报警器

RADIATOR GRILLE AND VACUUM

INDICATOR

序号 NO	件号 Part.No	名称 Designation	Name	数量 Quantit	适用车型 Suited type	备注 Remark
----------	---------------	-------------------	------	---------------	---------------------	--------------





1	DZ1642110044	散热器面罩	Radiator grille	1	
2	DZ1642110060	散热器护栅	Radiator protect handrail	1	
3	DZ1600930003	陕汽标志牌	Trade mark	1	
4	81.92501.0029	夹 箍	Clamp	15	
5	81.62440.0031	黑色铰链	Hinge black	2	
6	81.62440.0022	衬 垫	Packing	2	
7	Q2140625	十字槽盘头螺钉	Screw	6	M8×22-8.8-MAN183-B1
8	Q40206	大垫圈	Washer	6	
9	81.90201.0163	铰链销	Hinge pin	2	
10	81.62440.0023	气弹簧支架	Bracket	2	
11	Q2140616	十字槽盘头螺钉	Hex bolt	4	
12	Q40106	平垫圈	Washer	4	8×16×2-ST-A3C
13	81.74821.0095	气压弹簧	Gas spring	2	B8F8×25×19-CQ15K-A3C
14	06.21569.0046	销 子	Pin	2	B8F8×25×19-CQ15K-A3C
15	06.15120.0206	垫 片	Washer	10	8×16×2-ST-A3C
16	06.16029.0035	开口销	Cotter pin	4	
17	81.96002.0347	塞 子	Plug	2	
18	81.62410.2225	左前侧盖板	Left front side cover	1	
19	81.62410.2224	右前侧盖板	Right front side cover	1	
20	81.08309.6011	负压报警器	Vacuum indicator	1	
21	06.56936.0455	密封垫	Toric seal	1	9×2N-FPM170-GN
22	06.01283.5211	六角头螺栓	Hex bolt	1	M10×16-8.8-MAN183-B1
23	81.97487.0196	支 架	Angle	1	66×30×20
24	DZ9112190019	接 头	Hose nipple	1	5-M10×1-ST-A2C

带有散热器的护栏前面罩及负压报警器

RADIATOR GRILLE AND VACUUM

INDICATOR

帶有

INDIC

序 号

NO23

25

2

3

19

6

9

5

8

7

10

14

15

15

15

10

16

15

13

15

15

15

15

15

15

15

15

15

15

26

27

25

25

25

25

25

25

25

25

25

25

25

25

25

25

25

25

25

25

25

25

25

25

25

25

25

25

25

25

20

21

22

24

25

26

27

25

25

25

25

25

25

25

25

25

25

25

25

25

25

25

25

25

25

25

25

25

25

UUM

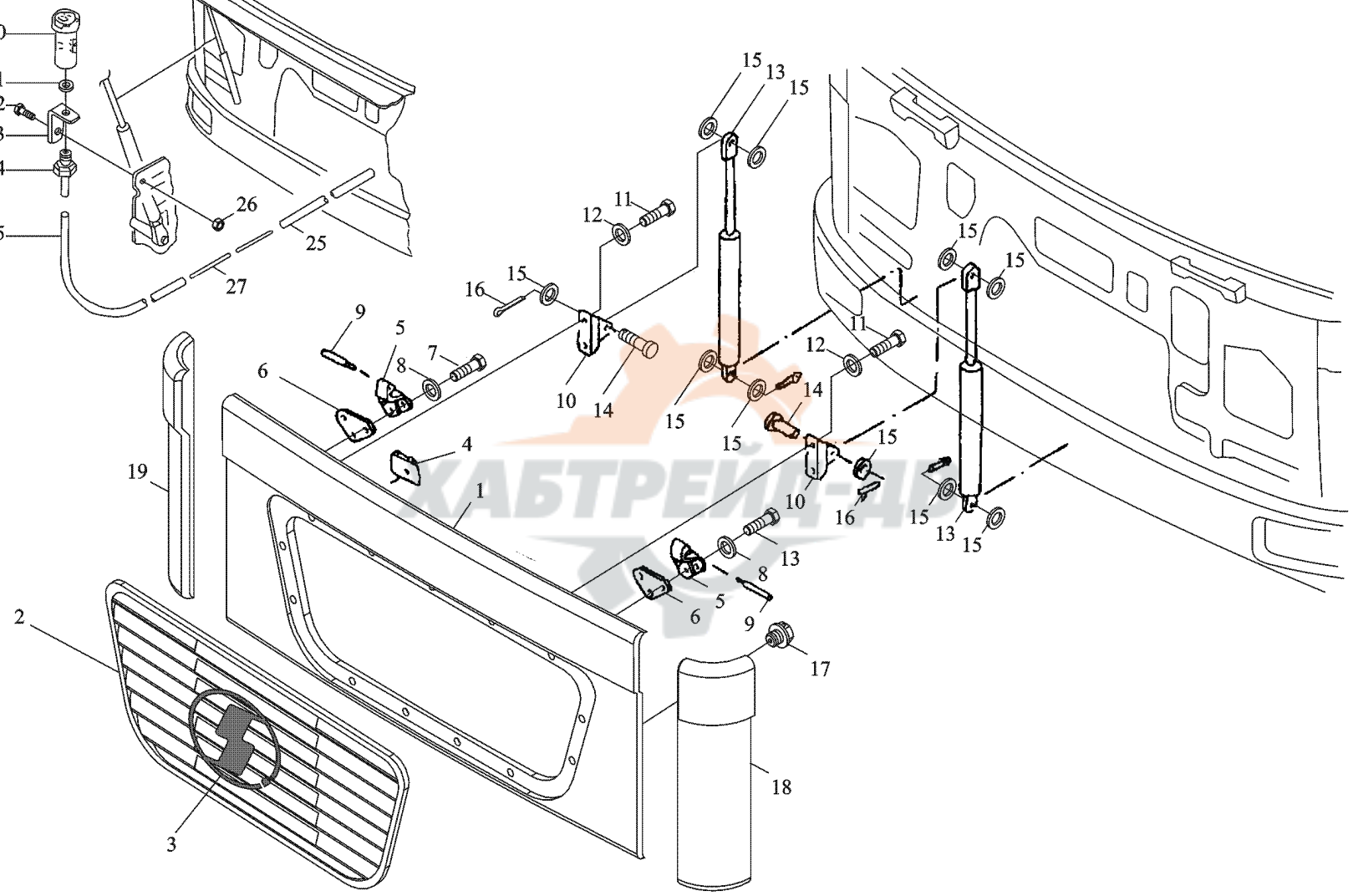

25	04.37135.9005	软管	Hose	NB		5×1.5-PVC-W-TR
26	06.11185.0115	六角螺母	Hexagon nut	1		M10-8-A3C
27	81.97401.0589	塑料紧固带	Cable binder	1		4.6×385-PA6.6-SW



刮水器系统 WIPER SYSTEM

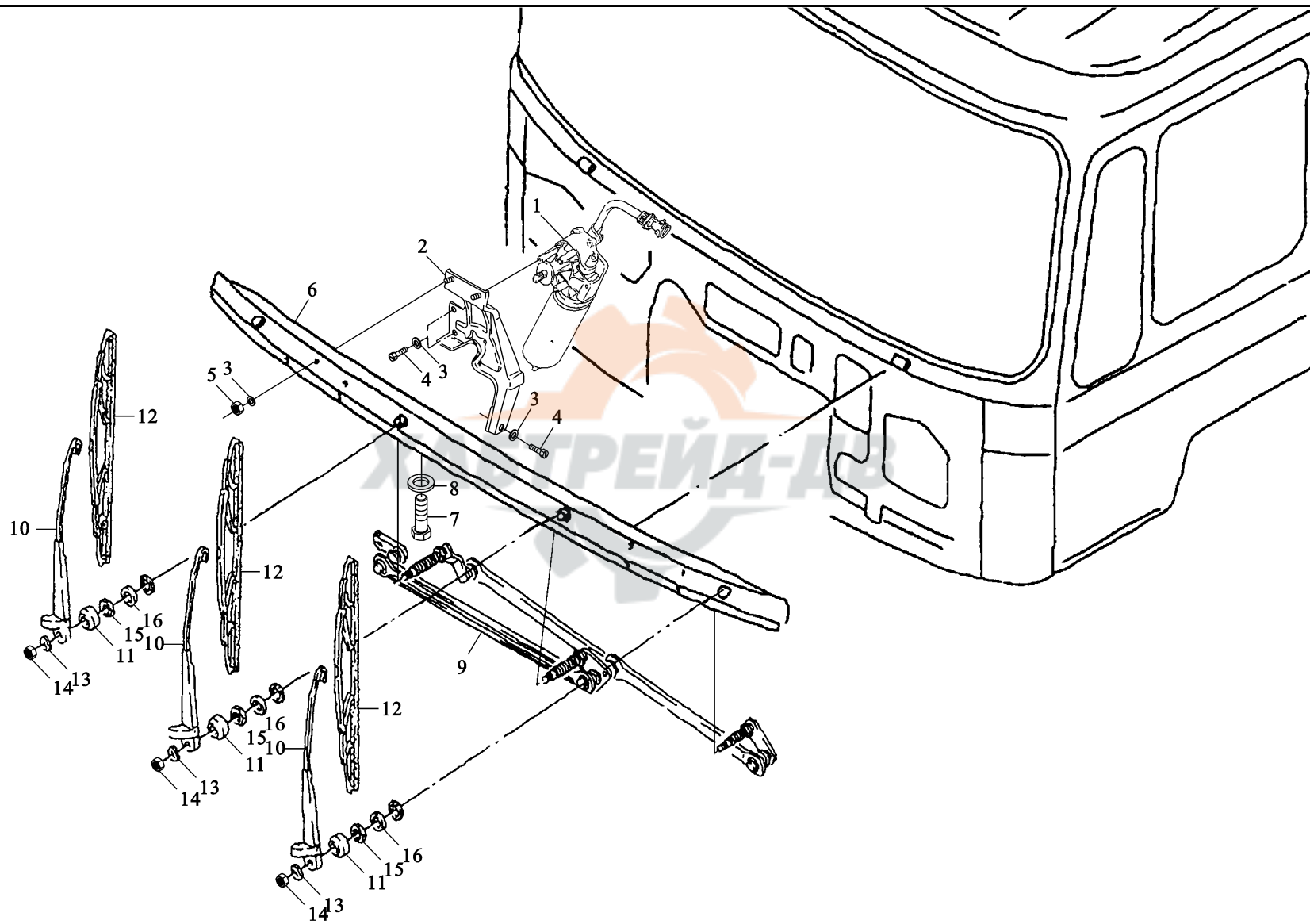

1	81.26401.6134	SWF 刮水器电动机	Wiper motor SWF	1		
2	81.26450.5035	支架总成	Bracket assembly	1		
	81.26450.5034	支架总成	Bracket assembly	1		
3	06.01289.0202	垫 片	Washer	3		A8.4×16×1.6-200HV-A3C
4	06.15013.6111	开槽螺栓	Hex bolt	3		M8×20SC-8.8-MAN183-A2C
5	06.11069.0157	自锁螺母	Hex collar nut	2		M8-8SB-8-SW13-MAN183-B1
6	81.62410.5031	加宽刮水器支架	Wiper carrier wide	1		
7	06.01289.0202	开槽螺栓	Hex bolt	6		M8×20SC-8.8-MAN183-A2C
8	06.15013.6111	垫 片	Washer	6		A8.4×16×1.6-200HV-A3C
9	81.26411.6093	BOSCH 刮水器连接杆	Wiper linkage assembly BOSCH	1		
	81.20411.6090	刮水器连接杆	Wiper linkage assembly	1		
10	81.26430.0116	SWF 刮水器臂	Wiper arm swf	3		
	81.26430.0083	刮水器臂	Wiper arm swf	3		
11	81.96410.0678	盖	Cap	3		
12	81.26440.0067	刮水器片	Wiper blade	3		
13	06.16043.0247	弹簧垫片	Spring washer	3		B10×18-A3C
14	06.11164.2115	六角螺母	Hexagon nut	3		M10-8-A3C
15	81.90714.0332	垫 圈	Washer	3		
16	81.90501.0113	螺 母	Nut	3		M26×1

# 带把手的加宽刮水器支架

# WIPER CARRIER WITH GRAB HANDLE

## 带把手的

序号	件
NO	P

备注  
Remark

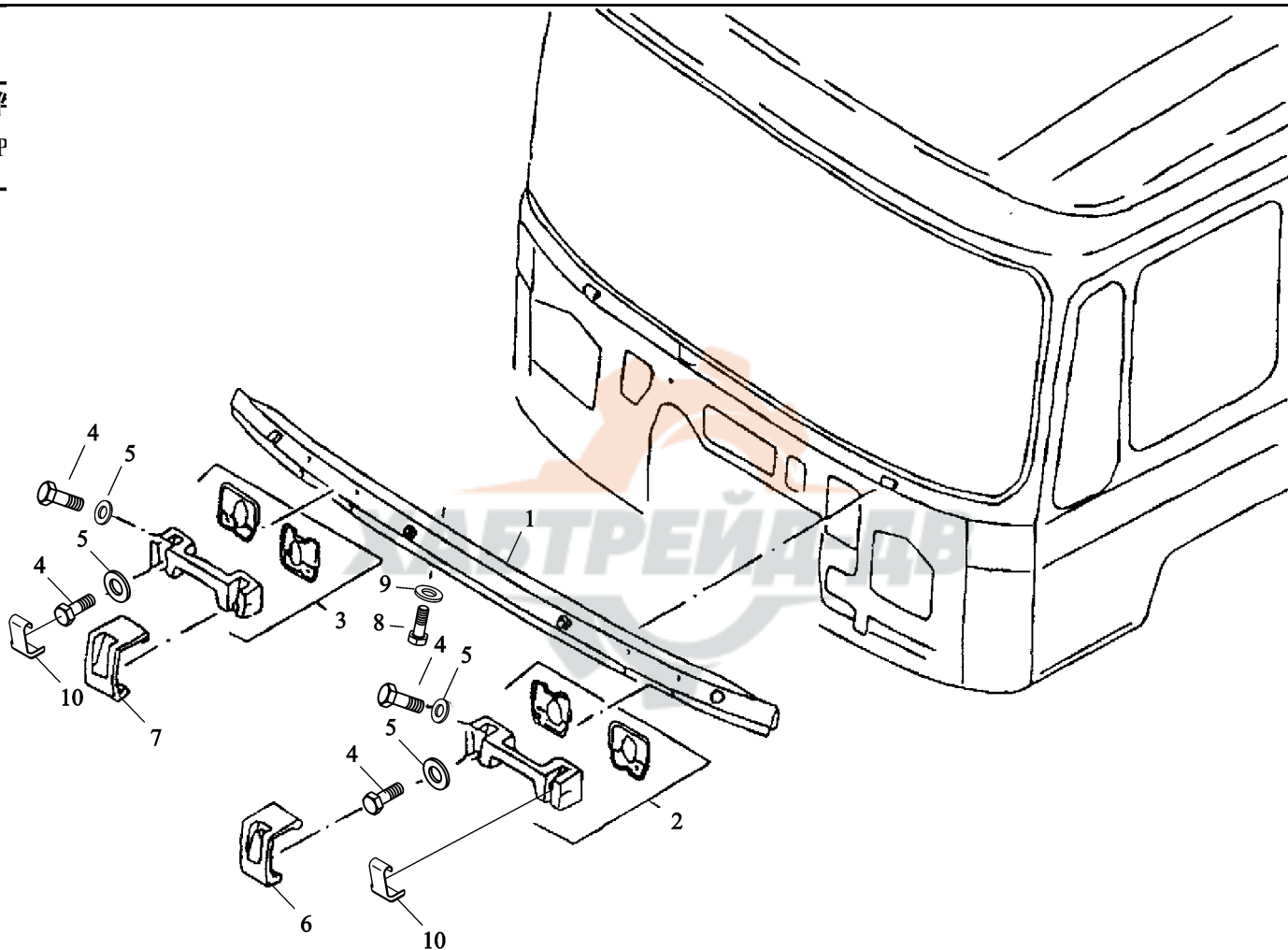

1	81.62410.5031	加宽刮水器支架	Wiper carrier wide	1	
2	81.97001.5081	左拉手总成	Grab handle assembly left	1	
3	81.97001.5082	右拉手总成	Grab handle assembly right	1	
4	06.01470.2413	六角螺栓	Hex bolt	8	M6×25SC-8.8-MAN183-A2C
5	06.15013.6109	平垫圈	Washer	8	A6.4×12×1.6-200HV- MAN183-B1
6	81.97001.0499	左 盖	Covering left	1	
7	81.97001.0498	右 盖	Covering right	1	
8	06.01289.0202	开槽螺栓	Hex bolt	6	M8×20SC-8.8-MAN183-A2C
9	06.15013.6111	垫 片	Washer	6	A8.4×16×1.6-200HV-A3C
10	81.97001.0501	左 盖	Covering left	1	
	81.97001.0500	右 盖	Covering right	1	

挡风玻璃喷洗泵和附件

WINDSCREEN WASHER PUMP AND ACCESSORIES

挡风玻

序号
NO

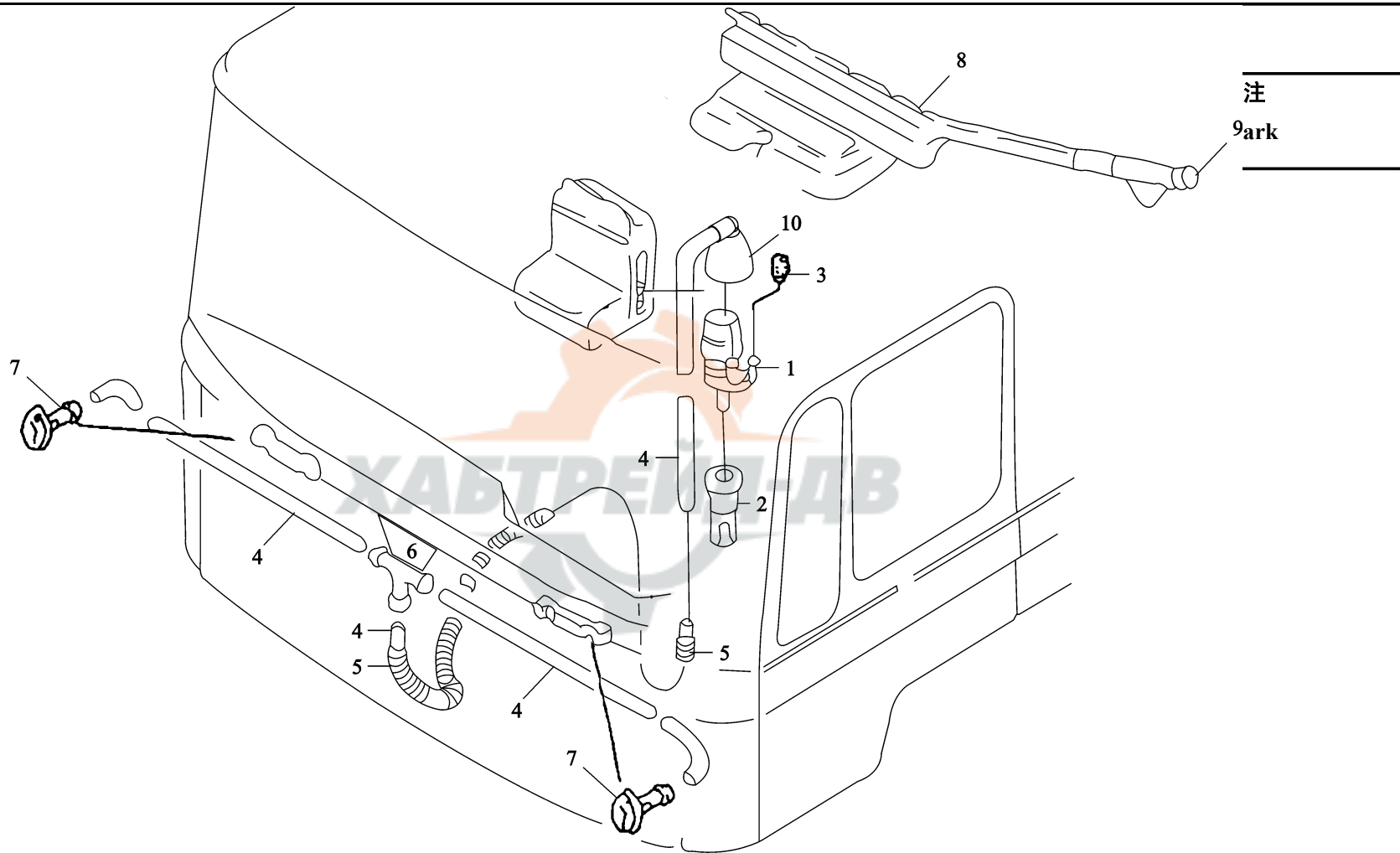



1	81.26485.6030	前挡风玻璃喷淋泵 (24V)	Windscreen washer pump	1		
			Single-pipe			
2	81.26481.0033		Water filter	1		
3	81.96410.0307	水滤清器	Plug	1		B5×16-CR-SW
4	04.37134.9004	螺 塞	Hose	5.6		4×1-PVC2-80-TR
5	04.37135.9940	软 管	Corrugated pipe	4.0		10×50000-PA6-SW
6	81.26483.0001	波纹管	Distributor	1		
7	81.26482.0025	三 通	Windscreen wash nozzle	2		
8	81.26481.6036	挡风玻璃冲洗嘴	Water container	1		
9	91.26481.0026	驾驶室后蓄水箱	Cover	1		
10	81.26412.0013	储水器盖 电机橡胶帽	Rubber cap	1		

挡风玻璃 WINDSCREEN

挡风玻璃

序号	
NO	

注
Remark

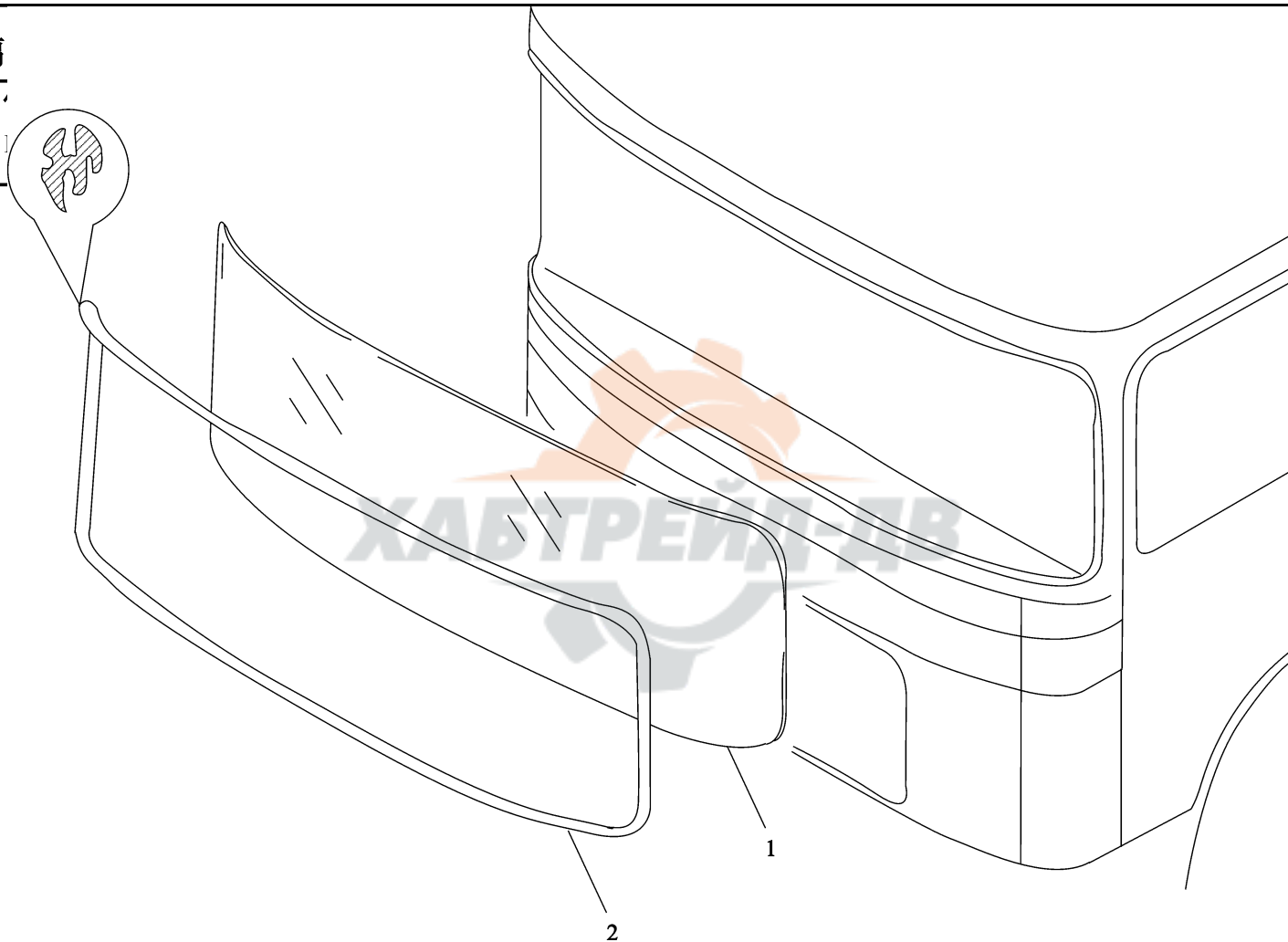

1	81.62450.0052	挡风玻璃	Windscreen	1		
2	81.96121.0056	挡风玻璃密封条	Seal strip	1		



扶手 HANDHOLD

扶手 H

序号	
NO.	

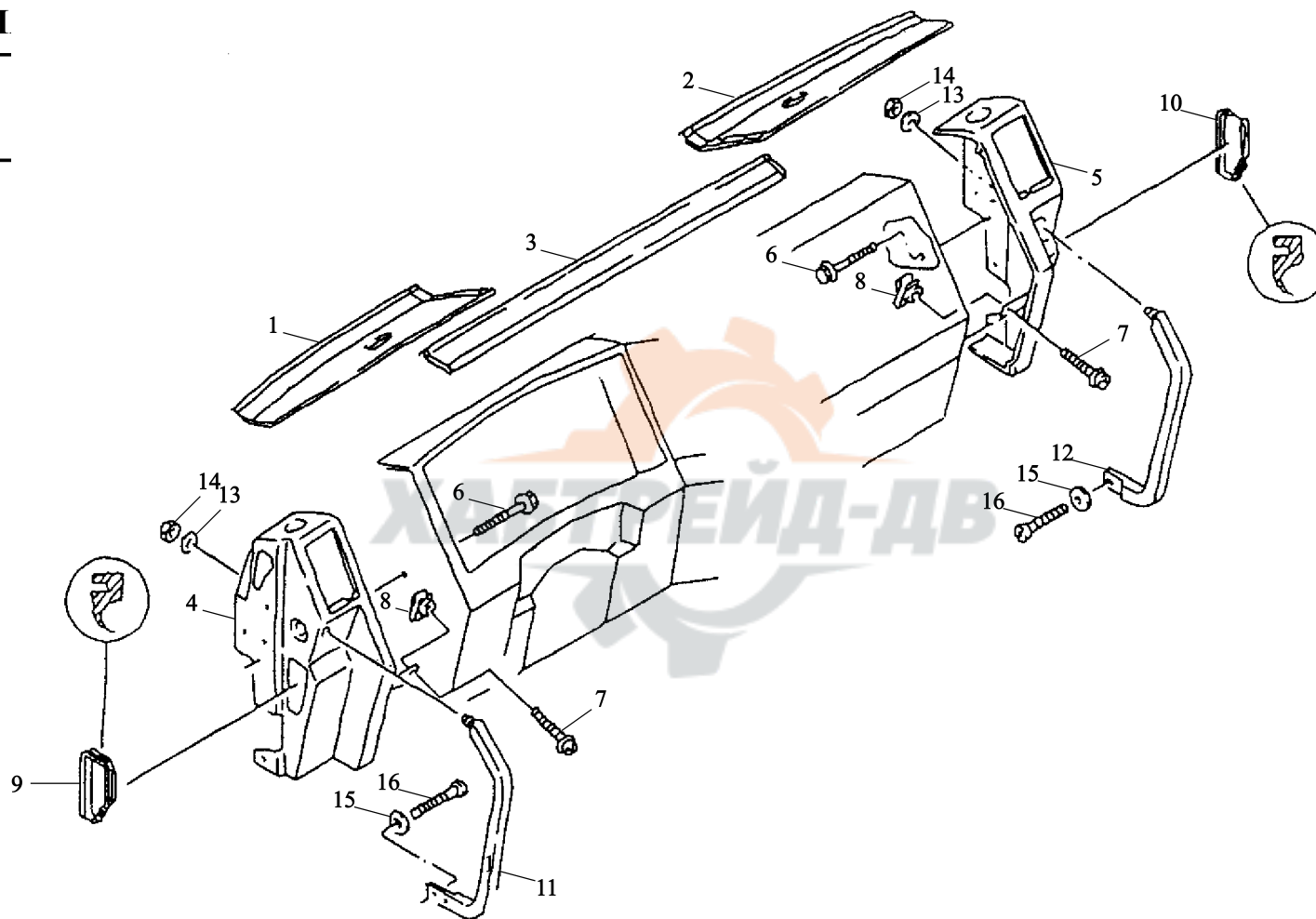

注  
mark

1	81.61701.5137	左盖板总成	Covering assembly left	1	
2	81.61701.5136	右盖板总成	Covering assembly right	1	
3	81.61701.0099	中间盖板	Covering center	1	
4	81.61701.5163	左仪表板总成	Dashboard side part assembly left wide	1	
5	81.61701.5162	右仪表板总成	Dashboard side part assembly right wide	1	
6	06.01470.6411	六角螺栓	Hex bolt	14	M6×20Z2-SC-8..8-MAN183-
7	06.04209.0035	盘头螺钉	Pan-head screw	2	A2C
8	06.13189.0056	簧片螺母	Slip-on nut	2	M6×20Z1-4.8-H-A2C
9	81.61950.0237	左门暖风密封件支架	Sealing frame left	1	M6-16×24×4.0-C45-ZN
10	81.61950.0244	右门暖风密封件支架	Sealing frame right	1	
11	81.61701.5165	左上车扶手	Handhold left	1	
12	81.61701.5164	右上车扶手	Handhold right	1	
13	06.15013.0412	垫 片	Washer	2	A10.5×20×2-200HV-
14	06.11185.0115	六角螺母	Hexagon nut	2	MAN183-B1
15	06.15230.0204	垫 片	Washer	4	M10-8-A3C
16	06.04201.4661	盘头螺钉	Pan-head screw	4	6.4×17×3-ST-MAN183-B1 M6×25SC-4.8-H-A3C

# 仪表板 DASHBOARD

## 仪表板

序号
NO

注  
mark

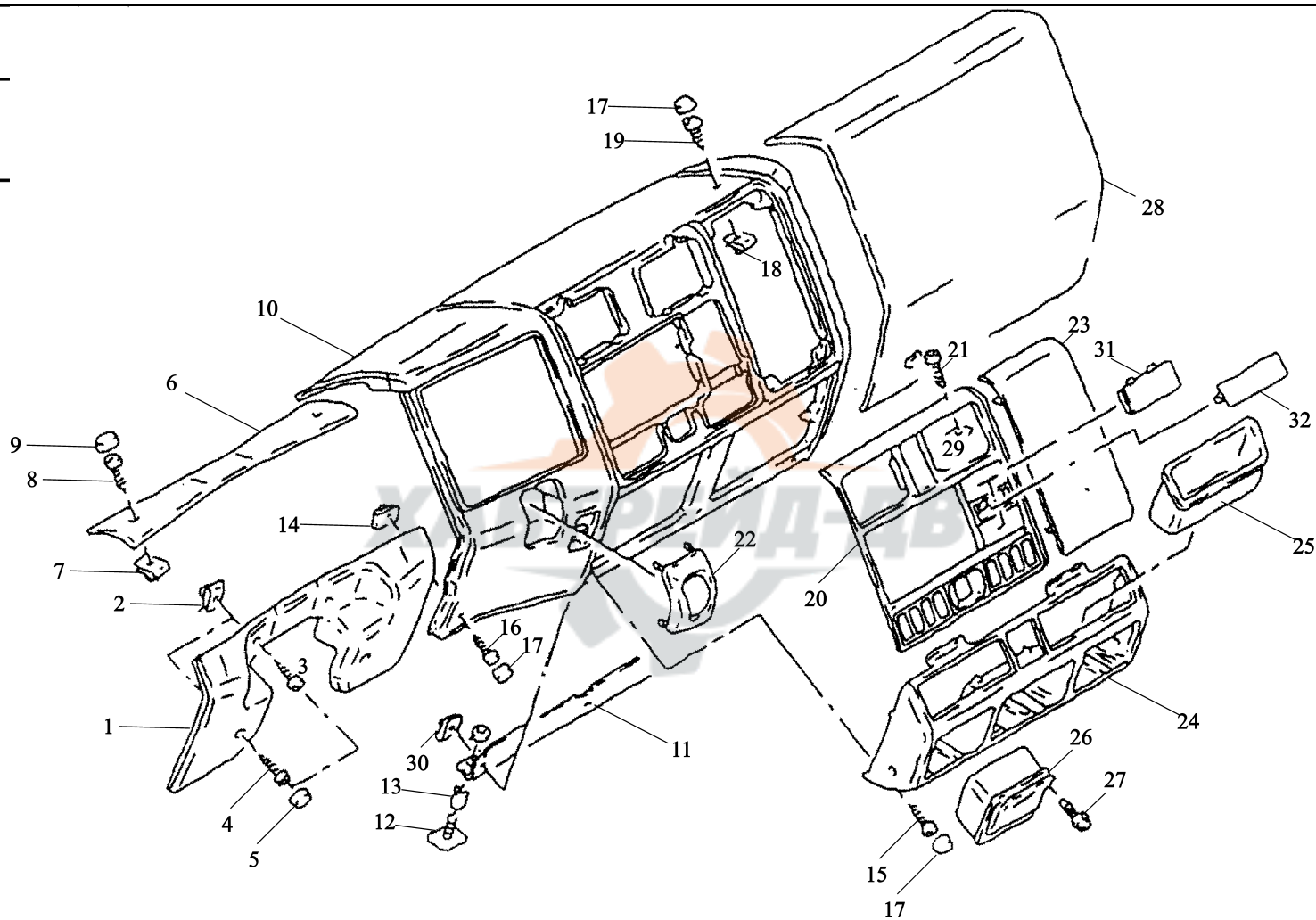

1	81.61701.0120	左下护盖	Covering lower	1	
2	06.13189.0051	簧片螺母	Speed nut	4	ST4.2-4-A3C
3	06.07158.4503	自攻螺钉	Oval-head self-tapping	2	ST4.2X13Z1-C-H-A3R
4	06.07158.4505	自攻螺钉	screw	2	ST4.2X19Z1-C-H-A3R
5	81.96002.0420	塞子	Oval-head self-tapping	4	
6	81.61701.0119	左上护盖	screw	1	
7	06.13189.0051	簧片螺母	Plug	2	ST4.2-4-A3C
8	06.07158.4503	自攻螺钉	Covering upper	2	ST4.2×13Z1-C-H-A3R
9	81.96002.0420	塞子	Speed nut	2	
10	81.61701.5169	中间护面	Oval-head self-tapping	1	
	81.61701.5170	中间护面	screw	1	右置车
11	81.61430.0053	中间护面下支架	Plug	1	
12	81.94289.0158	钢管	Center part assembly	2	
13	06.15013.0409	垫片	Center part assembly	3	A6.4×12×1.6-200HV- MAN183-B1
			Bracket		
14	06.13189.0051	簧片螺母	Steel tube	1	ST4.2-4-A3C
15	06.02099.0362	内六角圆柱头带垫螺钉	Washer	3	M5×30Z1-8.8-A2R
16	06.07158.4505	自攻螺钉		5	ST4.2×19Z1-C-H-A3R
17	81.96002.0420	塞子	Speed nut	5	
18	06.13189.0012	簧片螺母	Cylinder screw	4	ST4.2-2-A3C
19	06.07158.4505	自攻螺钉	Oval-head self-tapping	5	ST4.2×19Z1-C-H-A3R
20	81.61701.2227	点烟器装置板	screw	1	
21	06.07158.4505	自攻螺钉	Plug	4	ST4.2×19Z1-C-H-A3R
22	81.61701.0135	盖	Speed nut	1	
	81.61701.0134	盖	Oval-head self-tapping	1	右置车

仪表板 DASHBOARD

仪表板

序号
NO

注  
mark

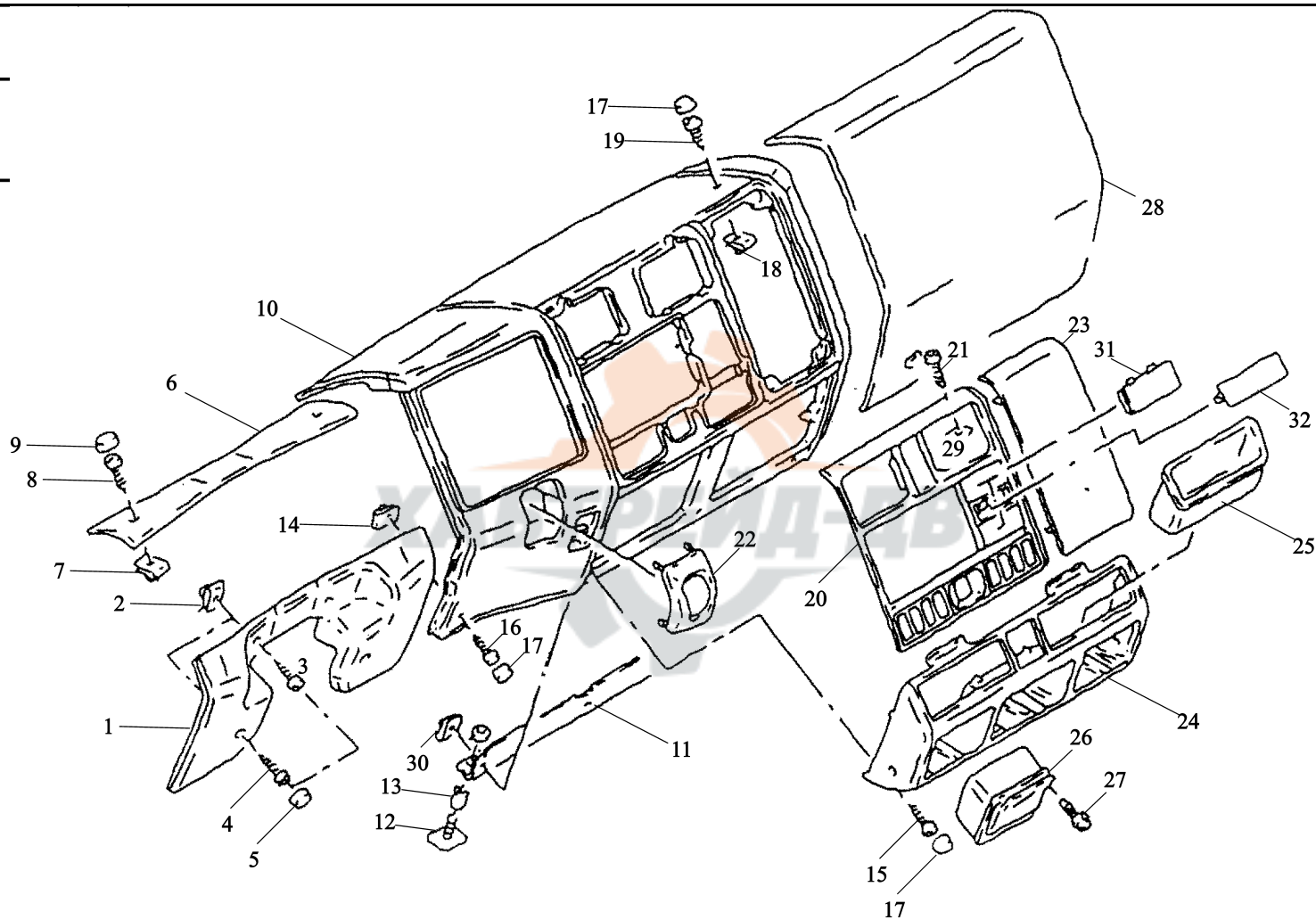



23	81.61701.0125	右中部装饰件	Cover plate center part	1		
	81.61701.0124	左中部装饰件	Cover plate center part	1		
24	81.61701.6179	中间部件总成	Center part assembly	1		
25	81.63745.0019	储物箱	Shelf	2		
26	85.63740.0003	烟灰缸	Ash tray	2		
27	81.90470.0611	十字槽盘头螺钉	Groove raised head Coll.screw	4		PT-KA4×16-WN1411-ST-A3C
28	81.61701.6178	电器箱盖总成	Covering assembly Electronics	1		
29	06.13189.0051	簧片螺母	Speed nut	4		ST4.2-4-A3C
	06.13189.0090	簧片螺母	Speed nut	4		ST4.2-11×15×4-CK67-A3C
30	06.13189.0051	簧片螺母	Speed nut	3		ST4.2-4-A3C
	06.13189.0091	簧片螺母	Slip-on cage nut	3		M5-14.5×17×2.0
31	81.61701.0123	点烟器板长堵盖	Cover for additional heater black	2		
32	81.61701.0150	盖	Cover	1		

诊断接口装置板 BRACKET DIAGNOSTIC SYSTEM

诊断卡

序号

NO

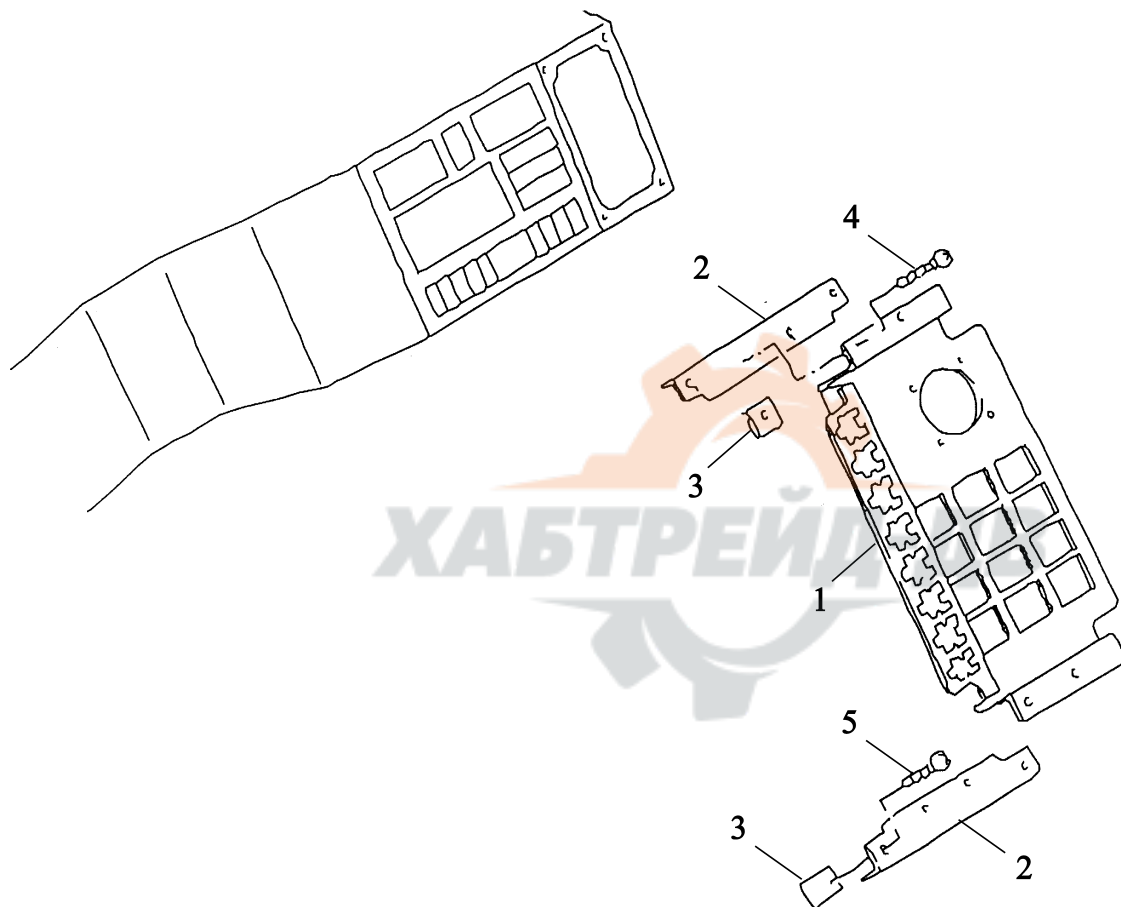

1	81.25441.0609	诊断接口装置板	Panel	1		
2	81.25441.0524	诊断接口装置板支架	Bracket	2		
3	06.13189.0039	簧片螺母	Nut	4		
4	06.07158.4503	半圆头十字槽自攻螺钉	Screw	4		
5	06.07158.4507	半圆头十字槽自攻螺钉	Screw	4		



辅助电气系统右护盖 COVERING RIGHT AUXILIARY ELECTRICAL SYSTEM

辅助电气系统右护盖

序号 NO	件号 Part.No
----------	---------------

STEM

备注 Remark
--------------

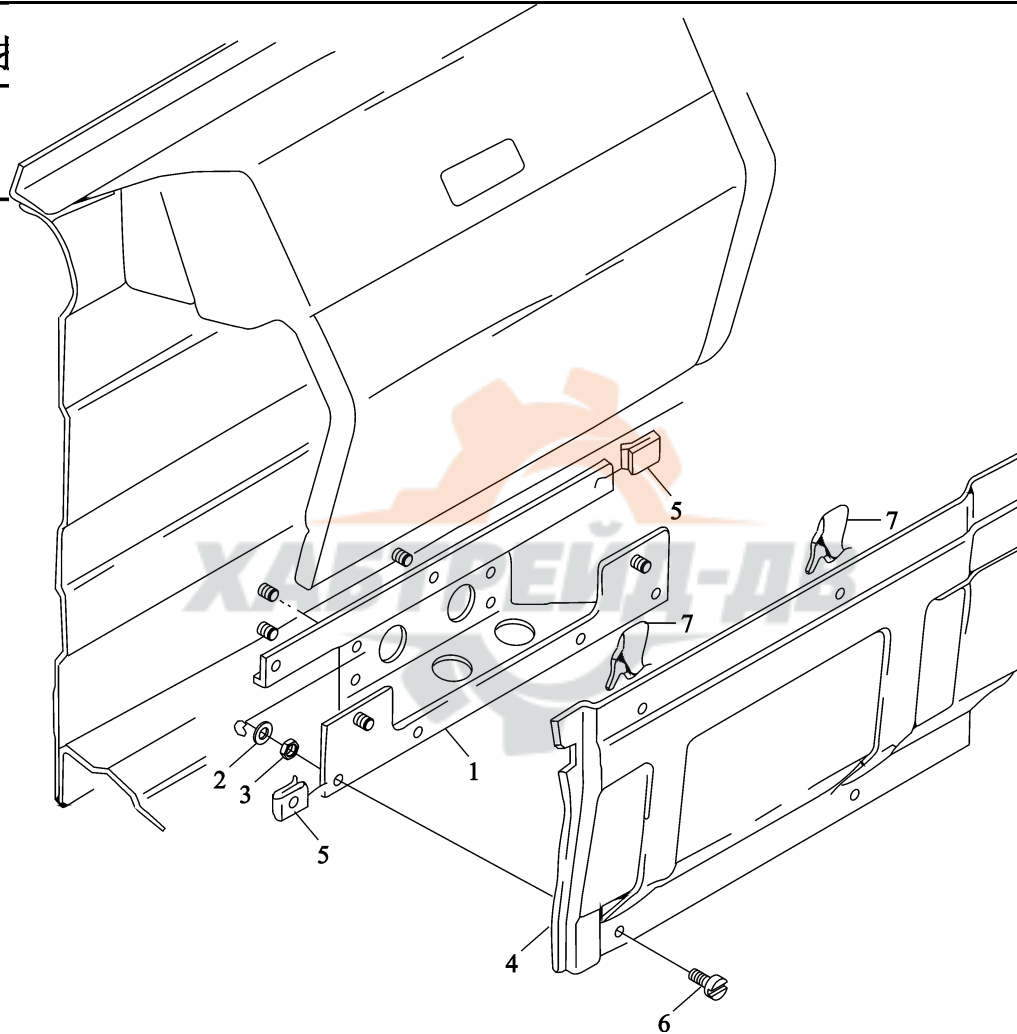

1	81.61443.2014	右仪表台下支架	Bracket	1		
3	06.11069.0144	六角螺母	Hex collar nut	4		M6—6SC-8-SW10-A3C
4	81.61430.0042	护盖	Covering	1		
	81.61430.0044	护盖	Covering	1		用于右置车
5	06.13189.0056	簧片螺母	Slip-on nut	4		M6-16×24×4.0-C45-ZN
6	06.04201.8657	盘头螺钉	Pan-head screw	2		M6×16Z2-4.8-H-A2R
7	81.97640.0266	卡子	Line clip	2		



# F2000 驾驶室空调 F2000 CAB AIR CONDITION

## F2000 驾驶室

序号	
NO	

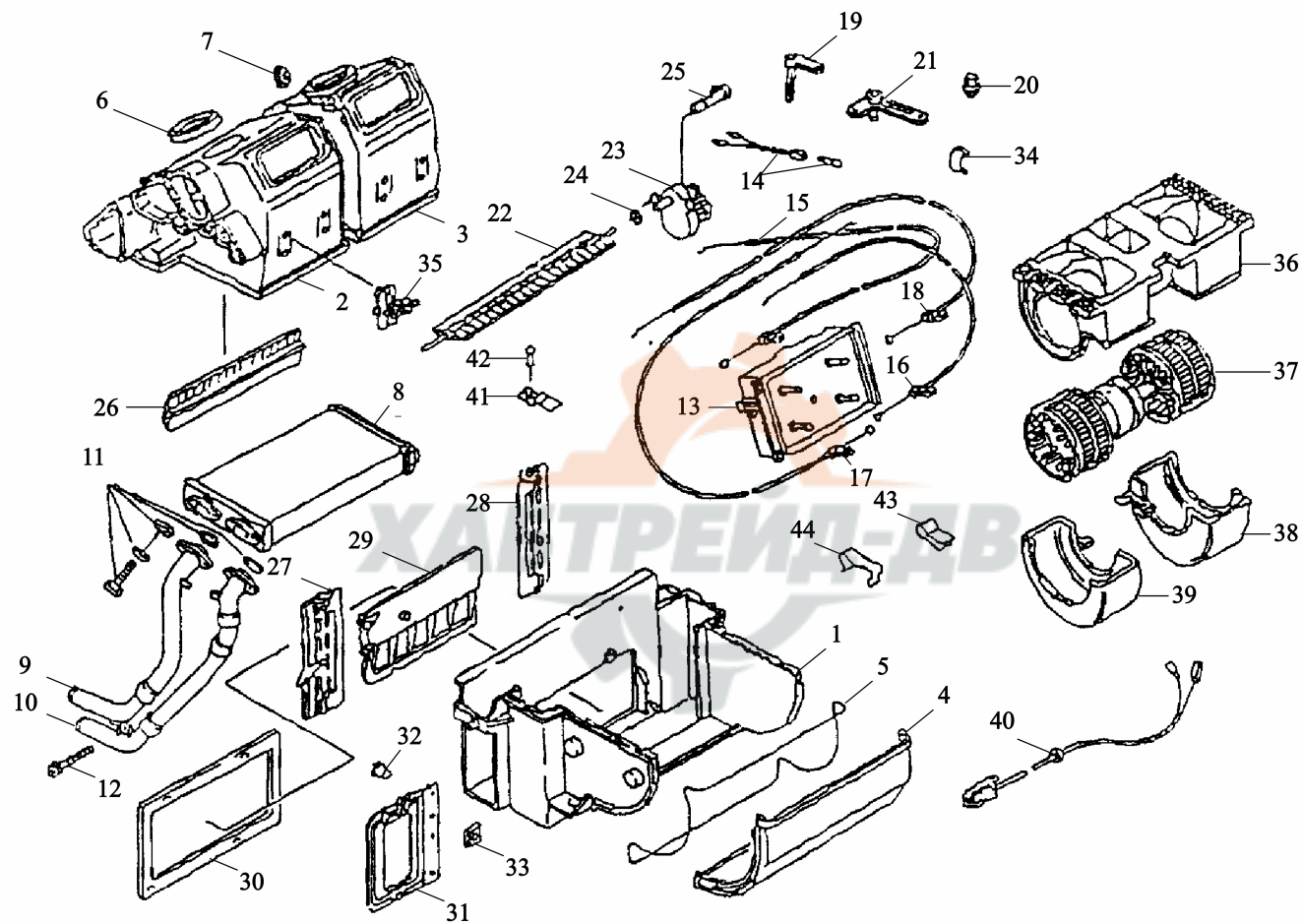

注	
emark	

1	81.61902.0075	壳体零件	Housing bottom part	1		
2	81.61902.0063	左壳	Housing left	1		
2	81.61902.0079	左壳	Housing left	1		
3	81.61902.0062	右壳	Housing right	1		
3	81.61902.0078	右壳	Housing right	1		
4	81.61942.0067	盖	Cover	2		
5	81.61951.0053	密封条	Sealing cord	1		
6	81.61951.0023	密封件	Seal	1		
7	81.61951.0051	密封垫圈	Sealing washer	1		
8	81.61901.0067	加热器	Heater	1		
9	81.61960.0616	暖风接管	Adapter	1		
10	81.61960.0660	暖风接管	Adapter	1		
11	81.61941.6015	装配件	Parts kit mounting	1		
12	81.90470.0611	螺钉	Grooved raised head coll	1		
13	81.61990.6054	控制开关总成	Control switch assembly	1		
14	81.25901.0104	小灯泡	Miniature bulb	1		
15	81.95501.0173	风门拉线	Bowden cable	1		
15	81.95501.0187	风门拉线	Bowden cable	1		
16	81.95501.0174	风门拉线	Bowden cable	1		
16	81.95501.0190	风门拉线	Bowden cable	1		
17	81.95501.0175	风门拉线	Bowden cable	1		
17	81.95501.0189	风门拉线	Bowden cable	1		
18	81.95501.0176	风门拉线	Bowden cable	1		
18	81.95501.0188	风门拉线	Bowden cable	1		
19	81.61972.0026	拉杆	Lever	2		

# F2000 驾驶室空调 F2000 CAB AIR CONDITION

## F2000 驾驶室

序号 NO	件号 Part.N
----------	--------------

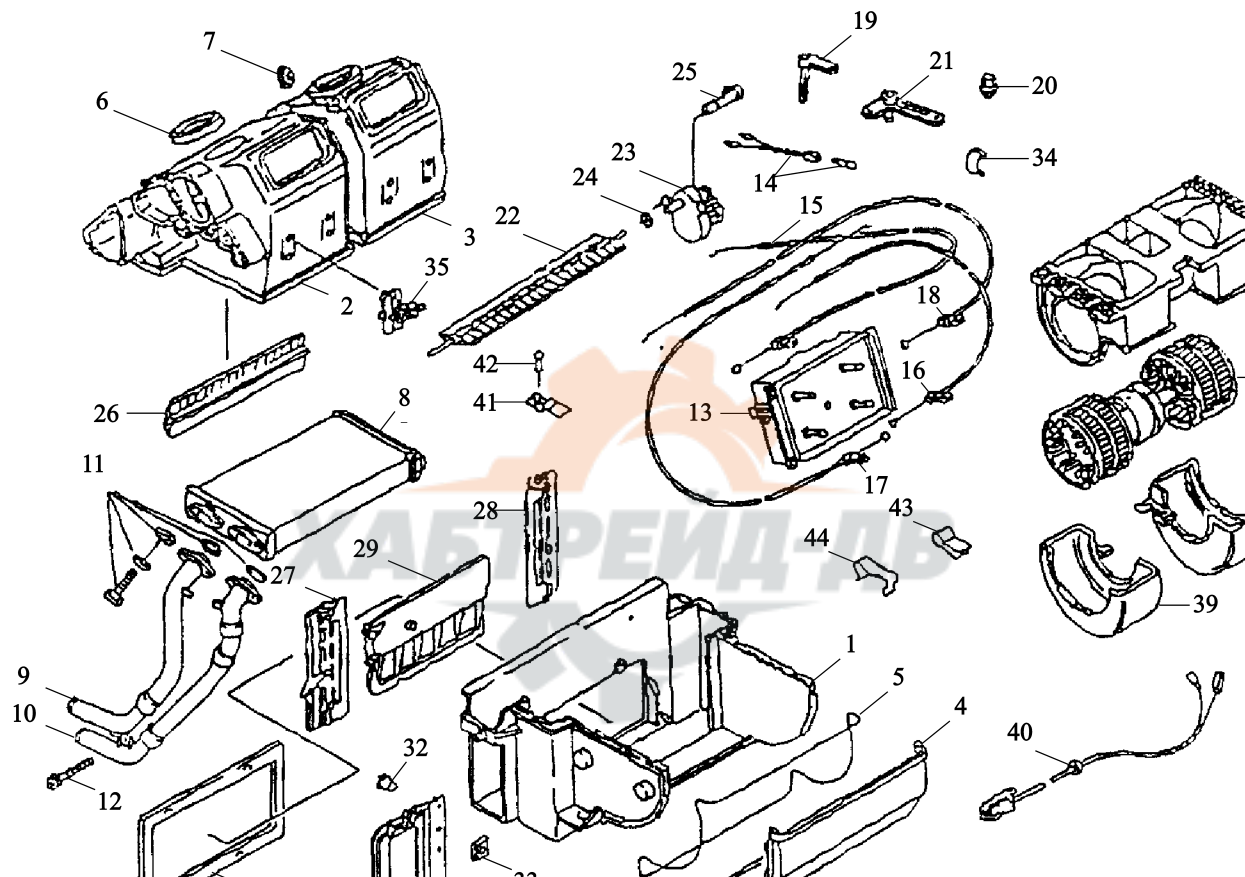

备注  
Remark



20	81.61990.0034	夹子	Clip	9		
21	81.61990.0066	拉杆	Lever	1		
22	81.61990.0083	活动板	Flap	1		
23	81.28601.6110	电机	Motor	1		
24	81.90820.0404	锁紧垫圈	Lock washer	1		
25	81.90490.0681	螺钉	Grooved raised head coll	2		PT-K3×10-WN1451-ST-T10
26	81.61990.0081	除霜板	Defroster flap	1		
27	81.61990.0079	左板	Flap left	1		
28	81.61990.0080	右板	Flap right	1		
29	81.61990.0082	换气片	Fresh air flap	1		
30	81.61951.0021	密封架	Sealing frame	1		
31	81.61940.0047	法兰	Flange	1		
32	81.92201.0098	铆钉	Blind rivet	4		A4×13-AL/ST-BK/A4C
33	81.90650.0018	螺母	Nut	6		
34	81.97640.0274	支持片	Retaining clip	30		
35	81.61941.0250	支架	Bracket	2		
36	81.61930.0054	鼓风机壳	Blower housing	1		
37	81.61930.0055	风扇	Fan	1		
38	81.61930.0053	半壳	Half shell	1		
39	81.61930.0052	半壳	Half shell	1		
40	81.25417.6818	电线束	Loom	1		
41	81.95510.0054	支架	Bracket	3		
42	06.24243.0221	铆钉	Blind rivet	3		
	81.61990.0063	装配夹	Mounting clamp	1		A4×13-ST-ST-A1P-A1P
	81.97640.0251	弹簧夹	Spring clamp	3		

# 加热和通风壳体部件

# COMPONENTS FOR HEATING AND VENT HOUSING

加热和通

序号	
NO	

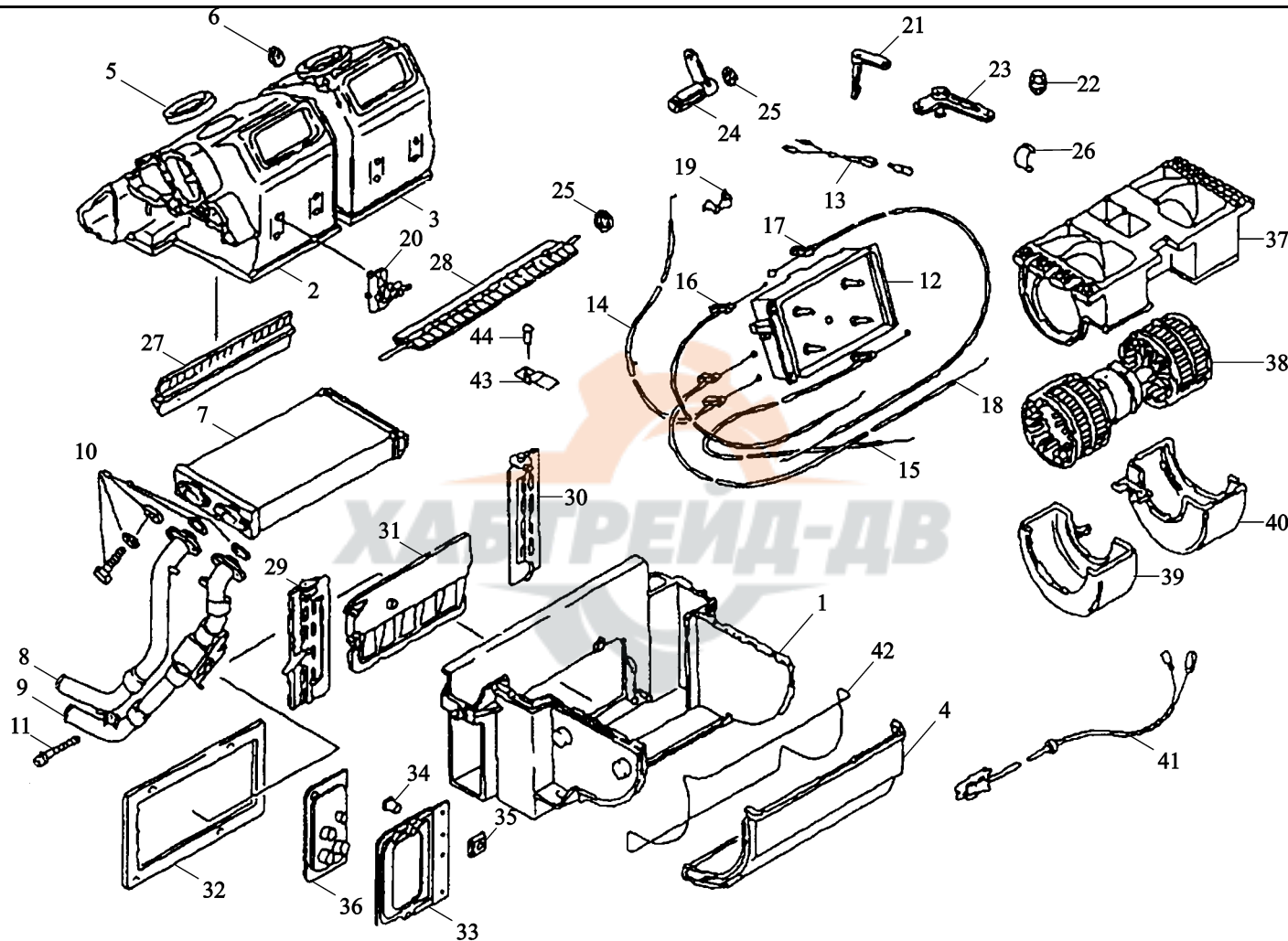

注  
mark

1	81.61902.0061	壳体底部	Housing bottom part	1		
	81.61902.0076	壳体底部	Housing bottom part	1		
2	81.61902.0079	左壳体	Housing left	1		
3	81.61902.0078	右壳体	Housing right	1		
4	81.61942.0067	盖	Cover	1		
5	81.61951.0023	密封件	Seal	2		
6	81.61951.0051	密封垫圈	Sealing washer	1		
7	81.61901.0067	加热器	Heater	1		
8	81.61960.0616	暖风接管	Adapter	1		
9	81.61980.0043	控制阀	Control valve	1		
10	81.61941.6015	装配件	Par kit mounting	1		
11	81.90470.0611	螺 钉	Grooved raised head coll.screw	1		PT-KA4×16-WN1411-ST-A3C
12	81.61990.6053	控制开关总成	Control switch assembly	1		LD24V-2.4W-W2×4.6D
13	81.25901.0104	小灯泡	Niniature bulb	1		
14	81.95501.0177	风门拉线	Bowden cable	1		
15	81.95501.0173	风门拉线	Bowden cable	1		
	81.95501.0187	风门拉线	Bowden cable	1		
16	81.95501.0174	风门拉线	Bowden cable	1		
	81.95501.0190	风门拉线	Bowden cable	1		
17	81.95501.0175	风门拉线	Bowden cable	1		
	81.95501.0189	风门拉线	Bowden cable	1		
18	81.95501.0176	风门拉线	Bowden cable	1		
	81.95501.0188	风门拉线	Bowden cable	1		
19	81.97640.0251	弹簧夹	Bowden cable	4		
20	81.61941.0250	支 架	Spring clamp	2		

# 加热和通风壳体部件

# COMPONENTS FOR HEATING AND VENT HOUSING

加热和通
序号
NO

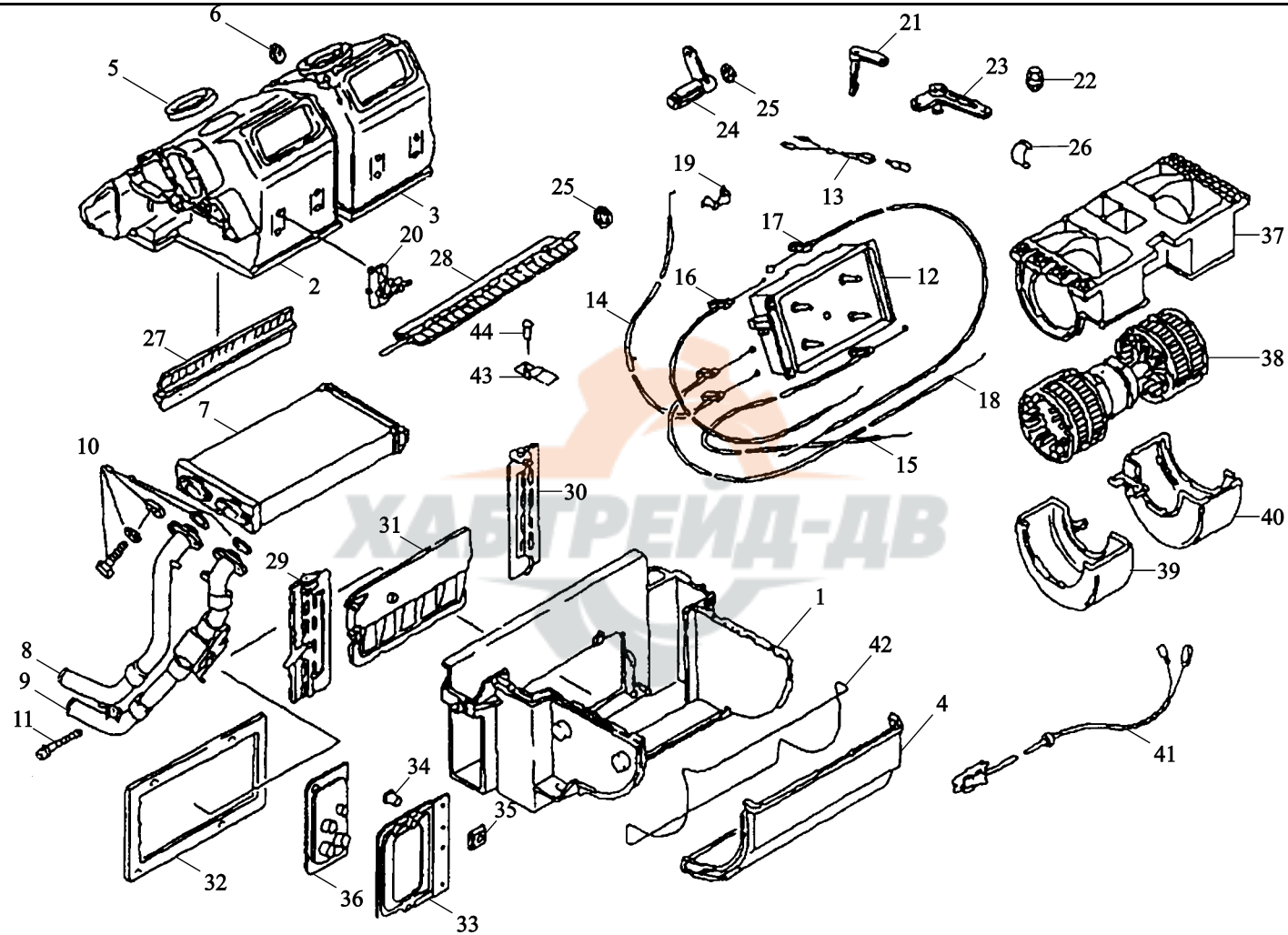

注  
mark

21	81.61972.0026	拉 杆	Lever	2	
22	81.61990.0034	卡 箍	Clip	9	
23	81.61990.0066	拉 杆	Lever	1	
24	81.61990.0067	拉 杆	Lever	1	
25	81.90820.0404	锁紧垫圈	Lock washer	2	
26	81.97640.0274	固定夹	Retaining clip	31	
27	81.61990.0081	除霜板	Defroster flap	1	
28	81.61990.0083	除箱板	Flap	1	
29	81.61990.0079	左挡板	Flap	1	
30	81.61990.0080	右除霜板	Flap right	1	
31	81.61990.0082	换气叶片	Fresh air flap	1	
32	81.61951.0021	密封圈	Sealing frame	1	
33	81.61942.0047	法 兰	Flange	1	
34	81.92201.0098	铆 钉	Blind rivet	4	A4×13-AL/ST-BK/A3C
35	81.90650.0018	螺 母	Nut	6	M8-16×18-8-A2C
36	81.61951.0022	衬 垫	Gasket	1	
37	81.61930.0054	鼓风机壳体	Blower housing	1	
38	81.61930.0055	风 扇	Fan	1	
39	81.61930.0052	半 壳	Half shell	1	
40	81.61930.0053	半 壳	Half shell	1	
41	81.25417.6818	线 束	Loom	1	
42					
43	81.95510.0054	支 架	Bracket	3	
44	16.24243.0221	铆 钉	Blind rivet	3	A4×13-ST-ST-A1P-A1P
	81.61990.0063		Mounting clamp	1	

# 带传感器的风机 BLOWER WITH SENSOR

## 带传感器的风机 BI

序号 NO	件号 Part.No	

备注 Remark

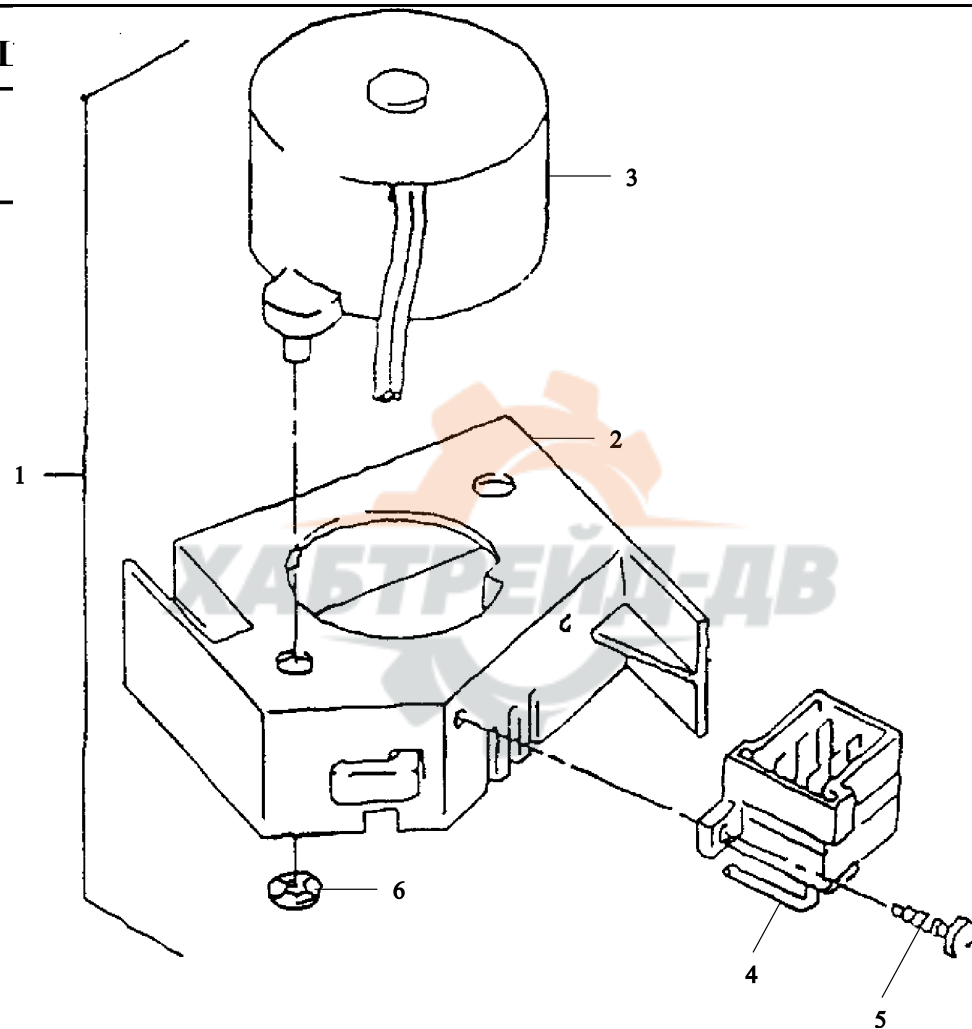

1	81.61930.6070	室内温度传感器	Blower with sensor	1	
2	81.61931.0002	支 架	Carrier	1	
3	81.61930.6067	风机总成	Blower assembly	1	
4	81.25435.0935	接 头	Plug	1	
5	81.90470.0608	螺 钉	Grooved raised head coll	2	PT-KA2.5×12-WN1411-10.9-
6	06.16119.0022	锁紧垫圈	Lock washer	2	A2B
	06.43839.0074	锁紧垫圈	Lock washer	2	



# 驾驶室进气装置 AIR INTAKE BOX ON CAB

驾驶室进

序号
NO

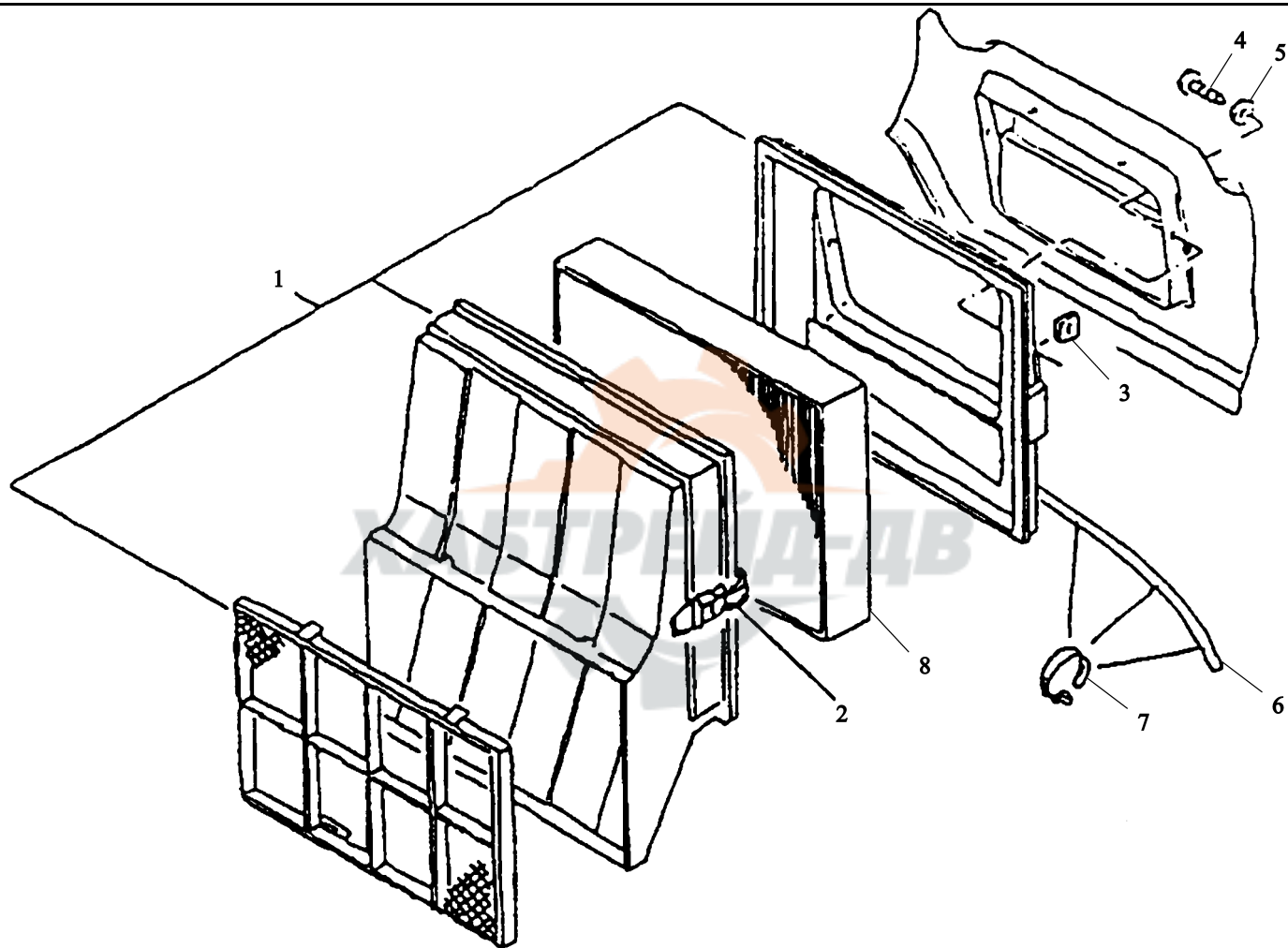

注  
mark



1	81.61950.6043	过滤器壳体总成	Filter housing assembly	1		
2	81.41860.0040	锁扣	Lock	2		
3	06.13189.0099	簧片螺母	Speed nut	4		ST4.8-2-MAN183-B1
4	06.07158.1604	自攻螺钉	Oval-head self-tapping	4		ST4.8×16C-H-A3R
5	06.15190.0306	垫圈	Washer	4		5.3×15×1.2-140HV-MAN183-B1
6	81.98405.0050	空调排水管	Polymide tube	0.5		
7	81.97401.0580	塑料紧固带	Cable binder	2		2.4×92-PA6.6-SW
8	81.61910.0011	风机进风口滤网	Pollen filter	1		



# 空气管道 AIR DUCT

空气  
序号  
NO

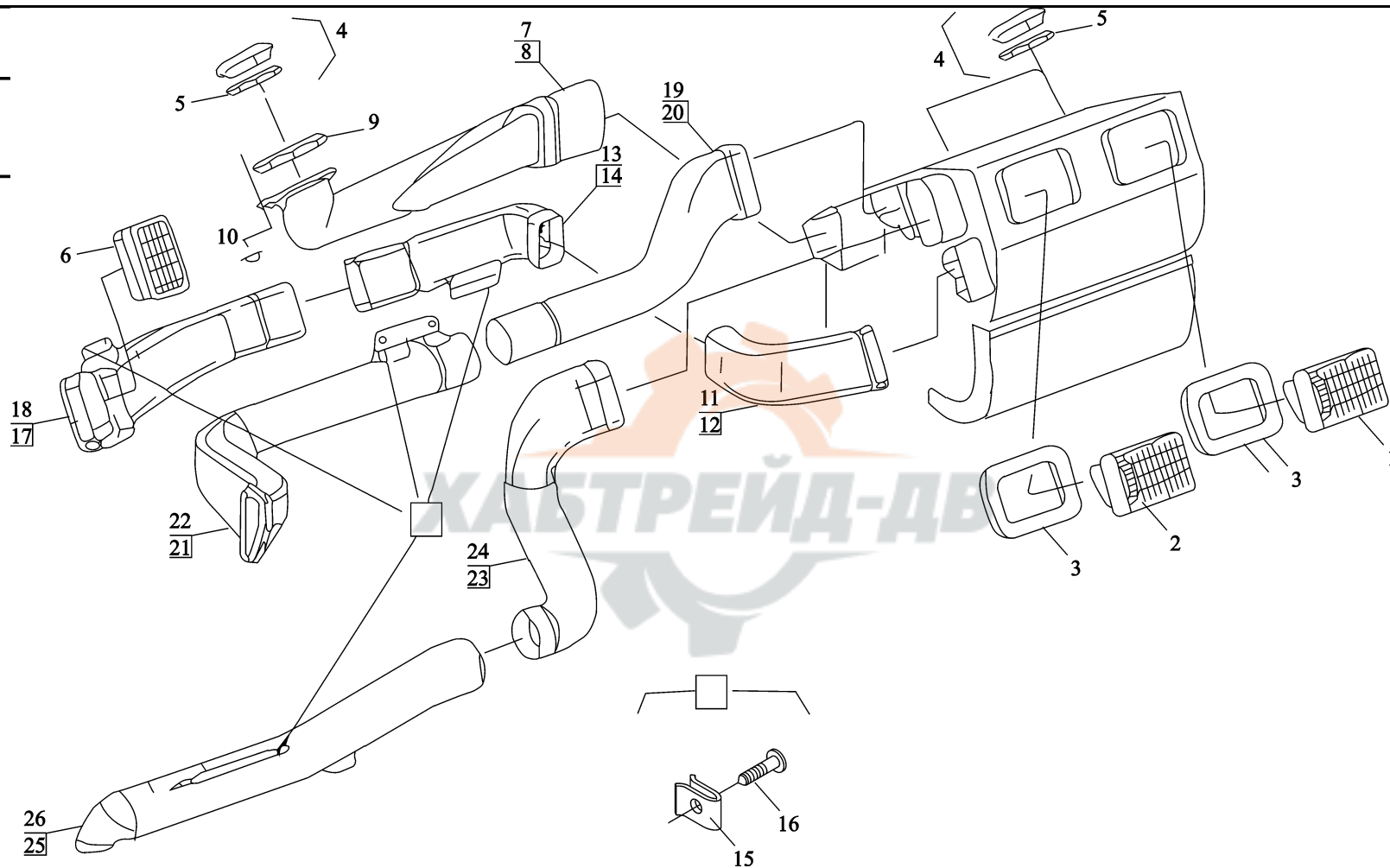

1	81.61950.0246	右空气出口	Air outlet right	1	
2	81.61950.0247	左空气出口	Air outlet left	1	
3	81.61951.2009	衬 垫	Gasket	2	
4	81.61951.6030	喷嘴总成	Nozzle assembly	4	
5	81.96501.2012	密封件	Seal	4	
6	81.61950.6028	方喷嘴	Nozzle	2	
7	81.61950.0213	左空气管道 除霜器	Defroster air duct left	1	
8	81.61950.0214	右空气管道 除霜器	Defroster air duct right	1	
9	81.61951.2003	非石棉衬垫	Gasket asbestos-free	2	
10	06.41159.0050	锁紧垫片	Lock washer	2	5-18-CK67/PVC-SW
11	81.61950.0239	左内空气管道	Air duct left inner	1	
12	81.61950.0238	右内空气管道	Air duct right inner	1	
13	81.61950.0229	左中侧空气管道	Air duct left	1	
14	81.61950.0228	右中侧空气管道	Air duct right	1	
15	06.07158.4504	自攻螺钉	Oval-head self-tapping screw	10	ST4.2×16Z1-C-H-A3R
16	06.13189.0051	簧片螺母	Speed nut	10	ST4.2-4-A3C
17	81.61950.0233	外左空气管道	Air duct left outer	1	
18	81.61950.0232	外右空气管道	Air duct right outer	1	
19	81.61950.0215	在车门一侧的左内空气 管	Air duct left inner on door side	1	
20	81.61950.0216	道 在车门一侧的右内空气 管	Air duct right inner on door side	1	
21	81.61950.0219	道 在车门一侧的左外空气 管	Air duct left inner on door side	1	

# 空气管道 AIR DUCT

空气  
序号  
NO

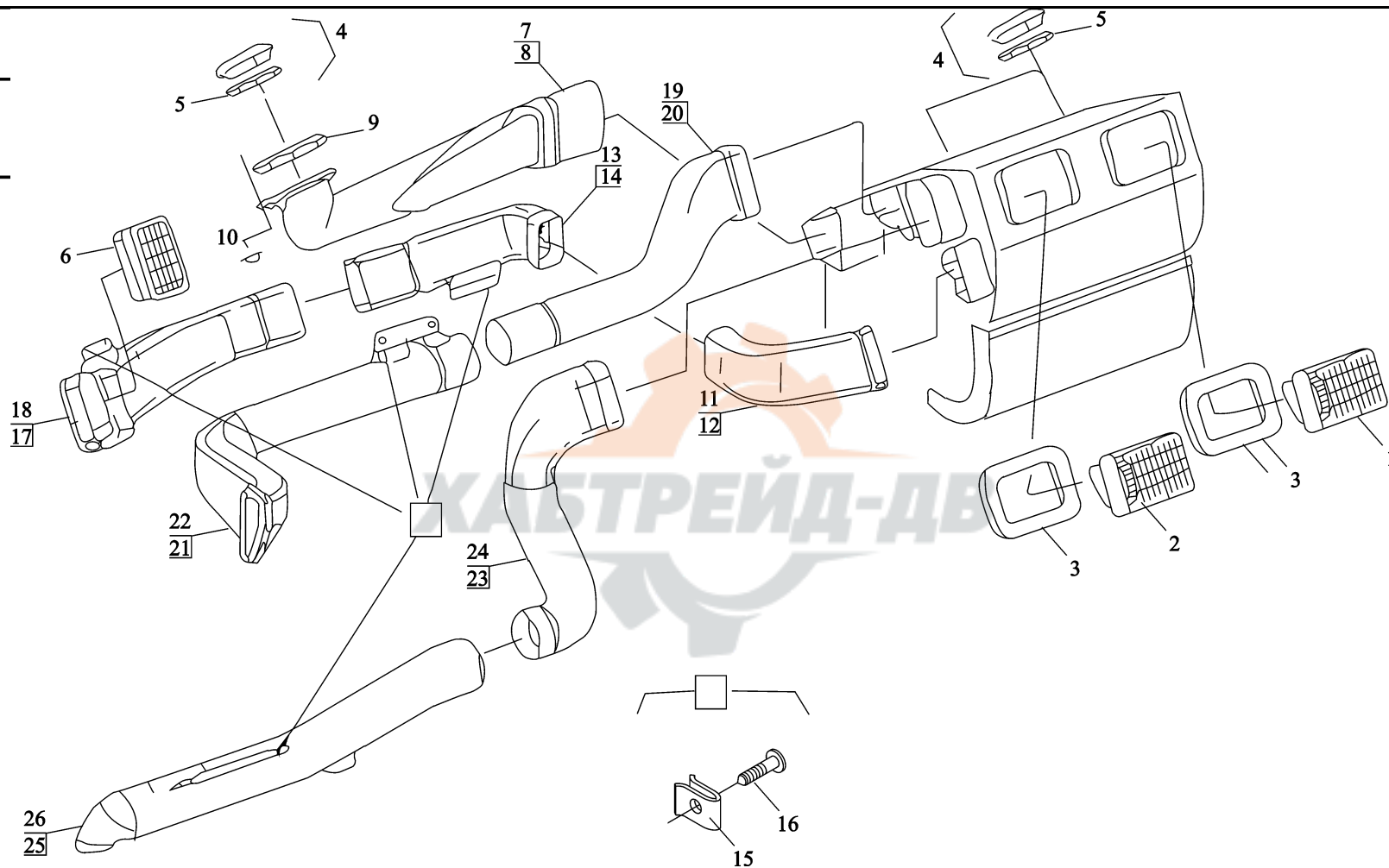

22	81.61950.0220	在车门一侧的右外空气 管道	Air duct right outer on door side	1		
23	81.61950.0223	左脚底内空气管道	Air duct left inner	1		
24	81.61950.0222	右脚底内空气管道	Air duct right inner	1		
25	81.61950.0225	左脚底风嘴	Footspace nozzle left	1		
26	81.61950.0224	右脚底风嘴	Footspace nozzle right	1		



# 暖风装置 (带空调) HEATER DEVICE (WITH AIR CONDITION)

暖  
风

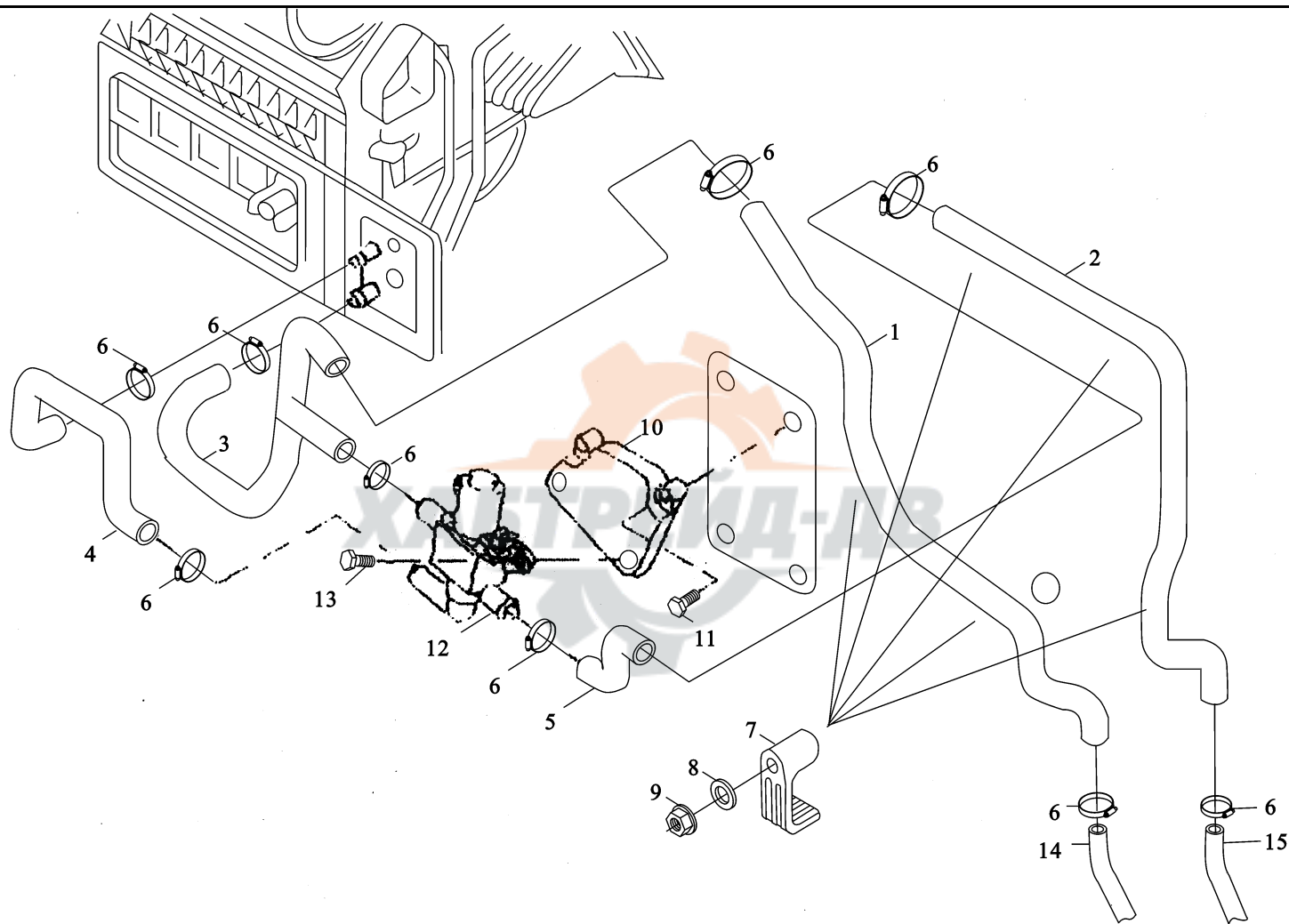

1	81.61960.0722	暖风水管	Heater line	1		22×1.5
1	81.61960.0721	暖风进水管	Heater line	1		
2	81.61960.0647	暖风回水管	Heater line	1		22×1.5
3	81.96301.0650	成型软管	Shaped hose	1		
4	81.96301.0651	成型软管	Shaped hose	1		
5	81.96301.0652	成型软管	Shaped hose	1		
6	06.67128.0711	卡箍	Hose clamp	7		AL27-31
7	81.97487.0484	支座	Bracket	5		
8	06.15013.0409	垫圈	Washer	5		A64×12×16-200HV-MAN183-B1
9	06.11240.0303	六角螺母	Hex lock nut	5		AM68-MAN183-B1
10	81.61940.0088	暖风控制阀支架	Plate	1		
11	06.09082.3714	自锁螺母	Self-tapping screw	2		DEM6×30-ST-A2C
12	81.61967.0016	控制阀	Control valve	1		
13	81.90470.0621	螺栓	To engine or auxiliary heater	2		PT-KA5×20-WN1411-10.9-A3R
14	16100840031	回水管	Outer pipe	1		
15	DZ1643840011	进水管	Inner pipe	1		

# 暖风装置（不带空调） HEATER DEVICE (WITHOUT AIR CONDITION)

## 暖风装置（

序号 NO	件 Part
----------	-----------

备注  
Remark

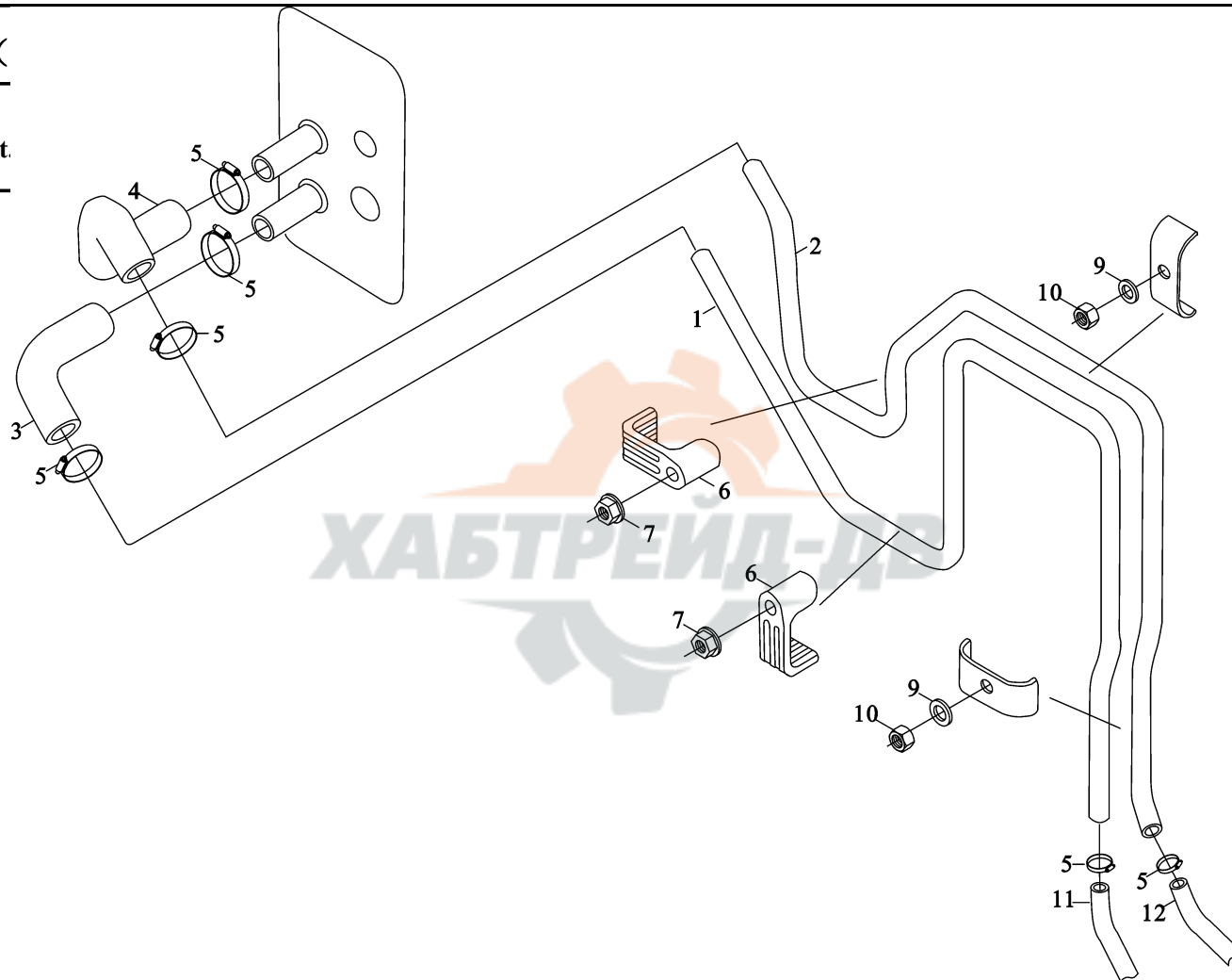



1	81.61960.0722	暖风进水管	Heater line	1	22×1.5
2	81.61960.0648	暖风回水管	Heater line	1	22×1.5
3	81.96301.0630	成型软管	Hose bend	1	22/22-25/25/40-EPMD5
4	81.96301.0631	成型软管	Shaped hose	1	22×22-MAN334-2
5	06.67128.0711	卡箍	Hose clamp	4	AL27-31
6	81.97487.0484	支架	Bracket	2	
7	06.11240.0203	六角锁紧螺母	Hex lock nut	2	AM6-8-MAN183-B1
8	06.67066.0213	双管卡	Mounting clamp	4	2×18-8-MAN183-B1
9	06.15190.0307	垫圈	Washer	2	6.4×18×1.6-140HV-MAN183-B1
10	06.11240.0303	螺母	Hex lock nut	2	AM6-8-MAN183-B1
11	16100840031	回水管	Outer pipe	1	
12	DZ1643840011	进水管	Inner pipe	1	

冷媒管路

MOUNTING FUEL REFRIGERANT PIPES

冷媒管路

序号 NO	件 P
----------	--------

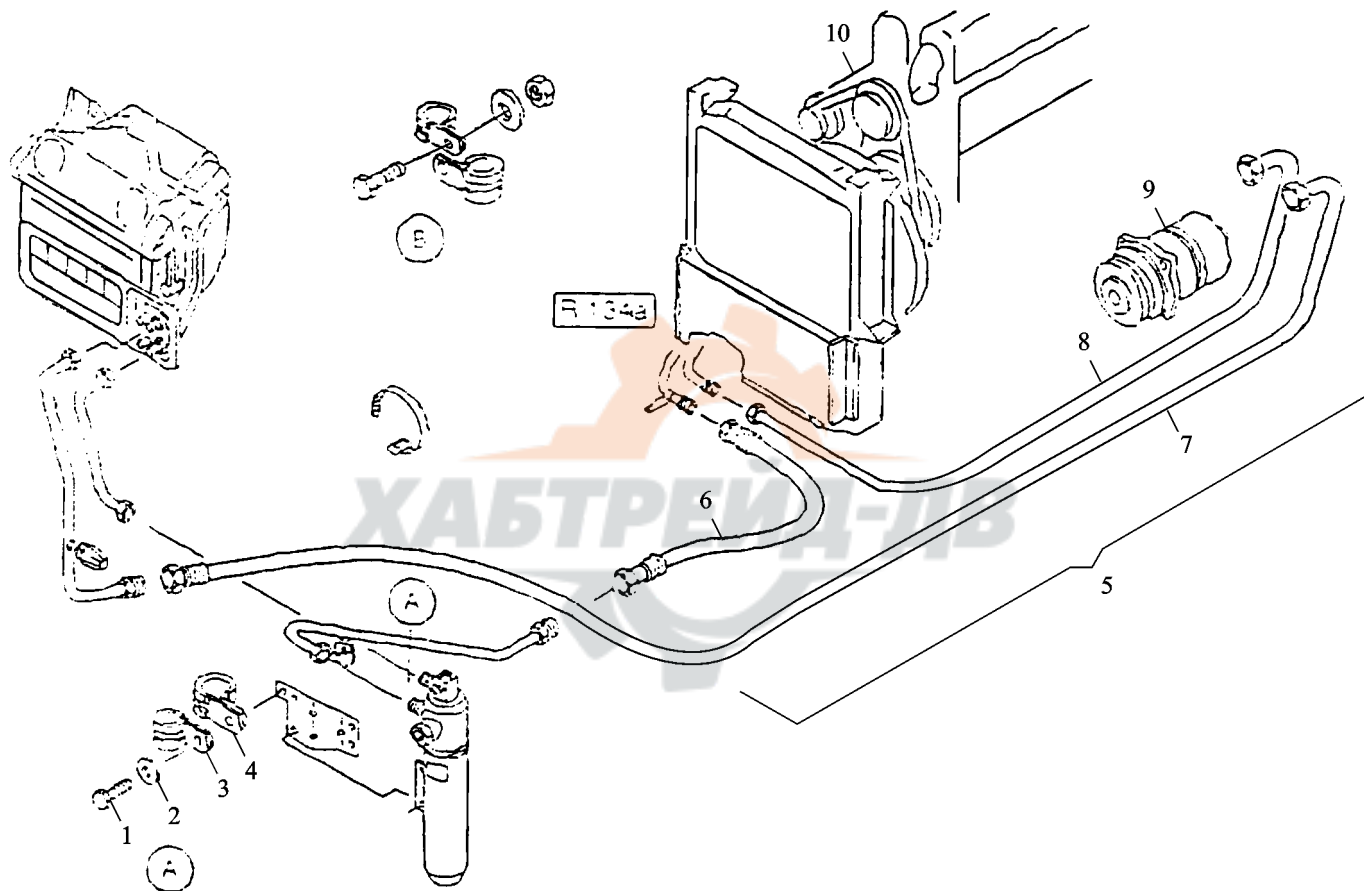

备注  
Remark

1	06.01470.1409	六角螺栓	Hex screw	2		M6×16Z-8.8-MAN183-Z2C
2						
3	81.97401.0771	管 夹	Clip	1		D1-110×15-W1
4	81.97401.0435	管 夹	Clip	1		
5	DZ1642840020	空调底盘件分总成	Air condition assy	1		冷凝器 - 干燥器
6	DZ1642840012	管 子	Pipe	1		包括 6~10
7	DZ1642840013	管 子	Pipe	1		
8	DZ1642840011	管 子	Pipe	1		冷凝器 - 储液罐
9	DZ1642840010	压缩机总成	Compressor	1		
10	DZ1642840014	空调压缩机皮带	Strap	3		蒸发器 - 压缩机
						蒸发器 - 压缩机
						1430

空调储液罐

FLUID RESERVOIR WITH MOUNTING

空调储液罐

序号	件号
NO	Part.N

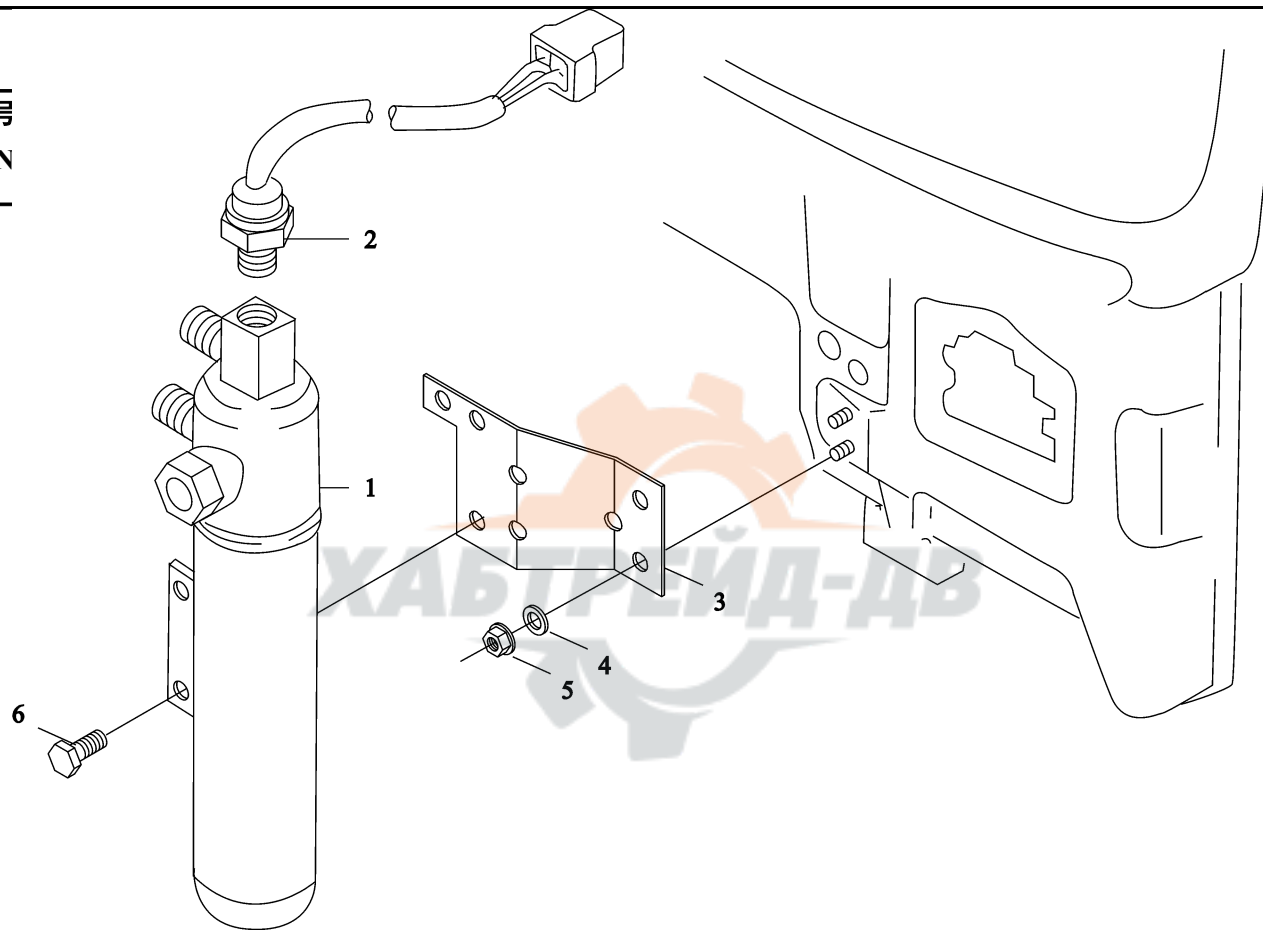

备注  
Remark

1	81.61910.6018	干燥罐	Fluid reservoir	1		
2	81.25503.6136	压力开关	Pressure switch	1		
3	81.61941.5087	支架总成	Bracket assembly	1		
4	06.15191.0207	垫 圈	Washer	2		6.4×18×1.6-140HV-MAN183-B1
5	06.11069.0156	六角螺母	Hex collar nut	2		M6
6	06.01470.1409	六角头螺栓	Hex bolt	2		M6×16



带支座的发动机罩绝缘体

ENGINE COWLING INSULATION WITH MOUNTING

带支座的

序号	件
NO	Pa

备注  
Remark

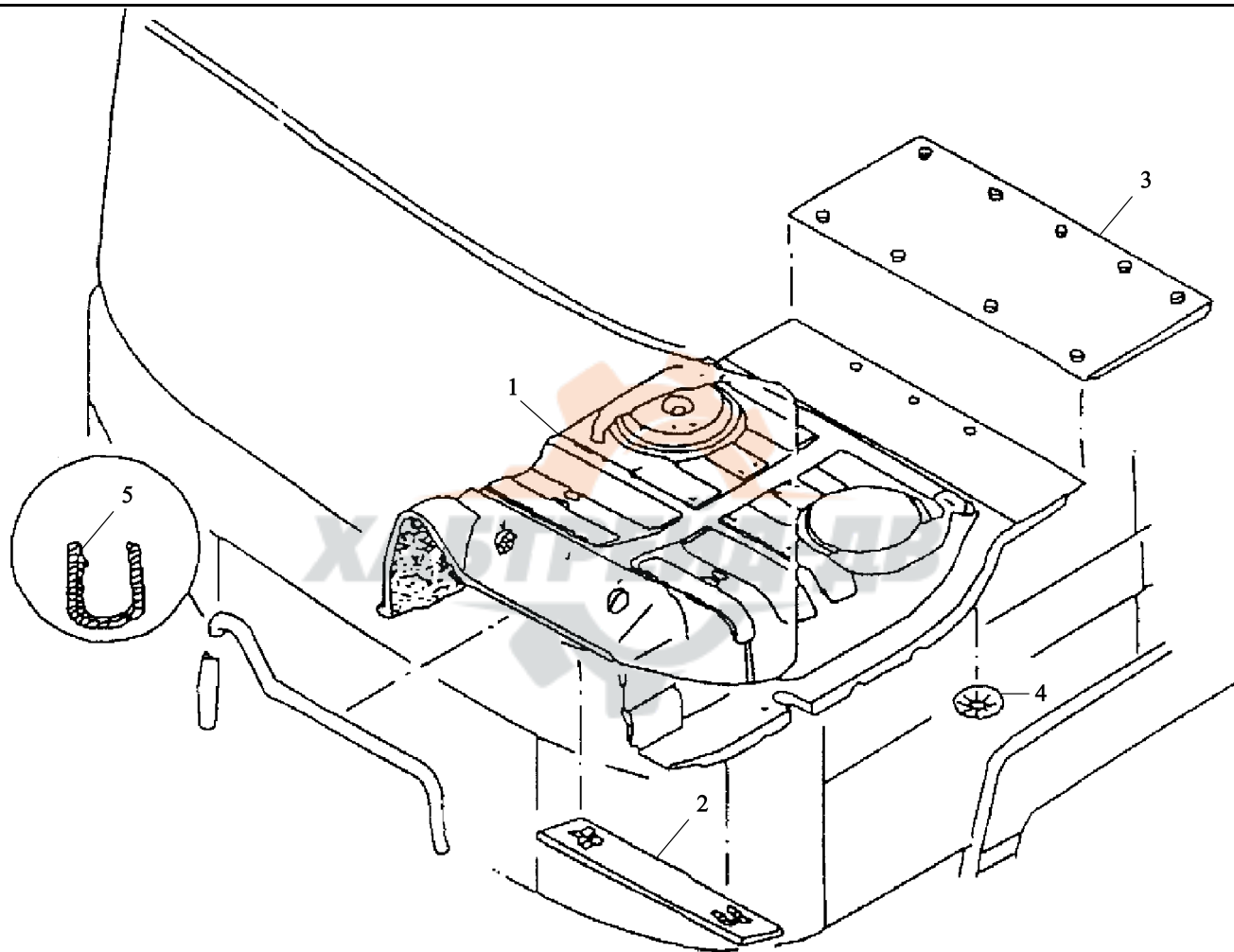

1	81.61370.0073	发动机下隔热垫	Engine cowling insulation	1		
	81.61370.0072	发动机下隔热垫	Engine cowling insulation	1		
2	81.61370.5006	护板	Anti-wear strip assembly	1		
3	81.61370.0052	发动机隔热板	Engine cowling insulation rear	1		
4	81.90820.0340	紧止垫圈	Lock washer	36		5-22-X12CRNI177
5	04.39535.9106	前围镶条	Anti-collision strip	1.4m		



# 地板和发动机罩 FLOOR PLATE AND ENGINE COWLING

地板和发

序号	件
NO	Pa

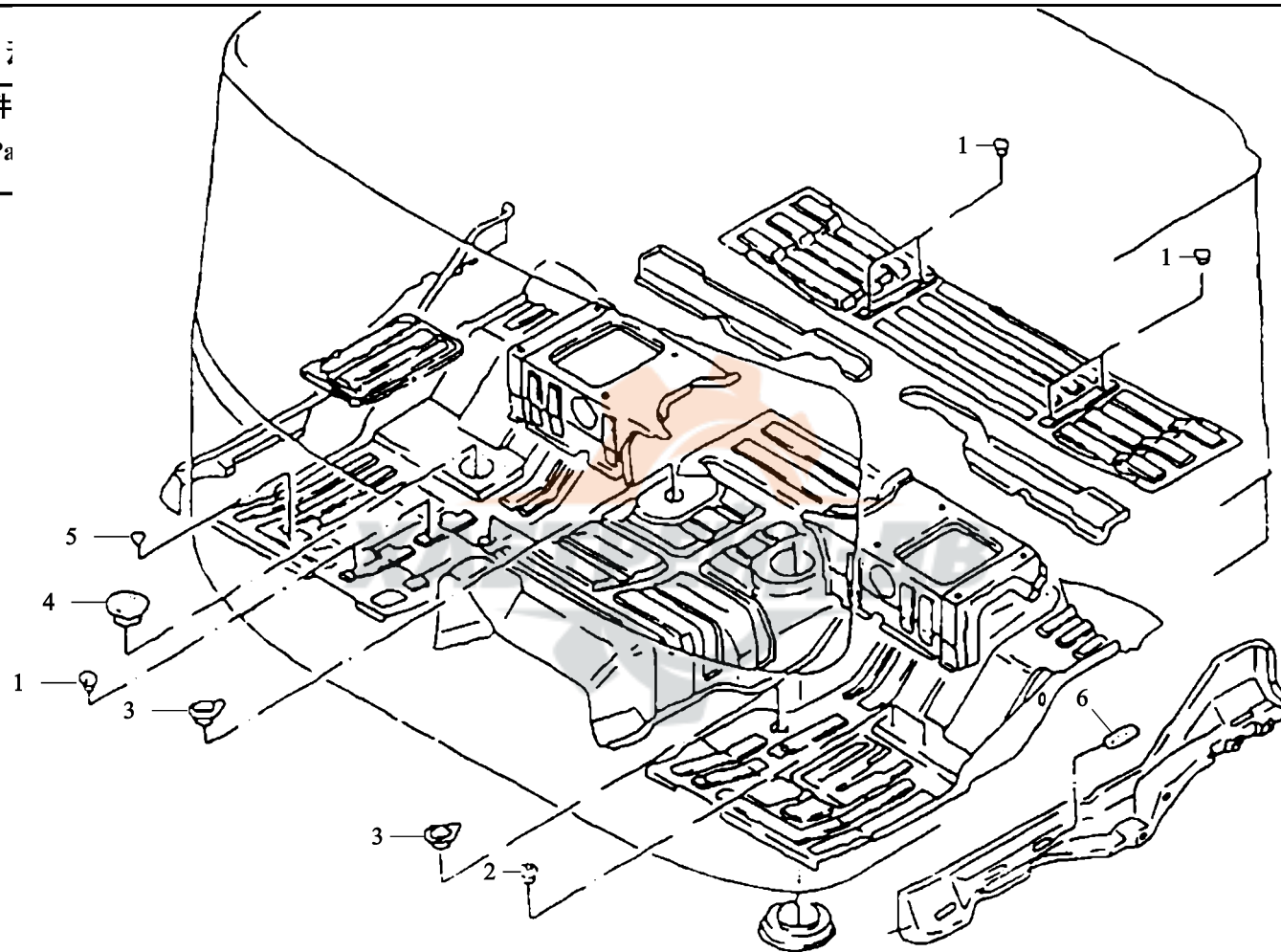

备注  
Remark



1	81.96002.0154	堵 塞	Plug	25		20.7×8-25-PE-SW
2	81.96002.0428	塞 子	Plug	2		20.7×8-25-PE
3	81.96002.0308	帶有凸耳的锥形罩	Tapered plug with tab	3		
4	81.96002.0312	塞 子	Plug	1		102.5×18-124-PE
5	81.96002.0063	塞 子	Plug	6		8.4×6-14-PE
6	81.96410.0502	塞 子	Plug	10		85.5×20.6×7-89×24-M3165-P2



前地板垫和防滑条

FLOOR MATS FRONT AND ANTI-SKID STRIP

前地板垫和防滑条

序号 NO	件号 Part.No	De
----------	---------------	----

车型 d type	备注 Remark
--------------	--------------

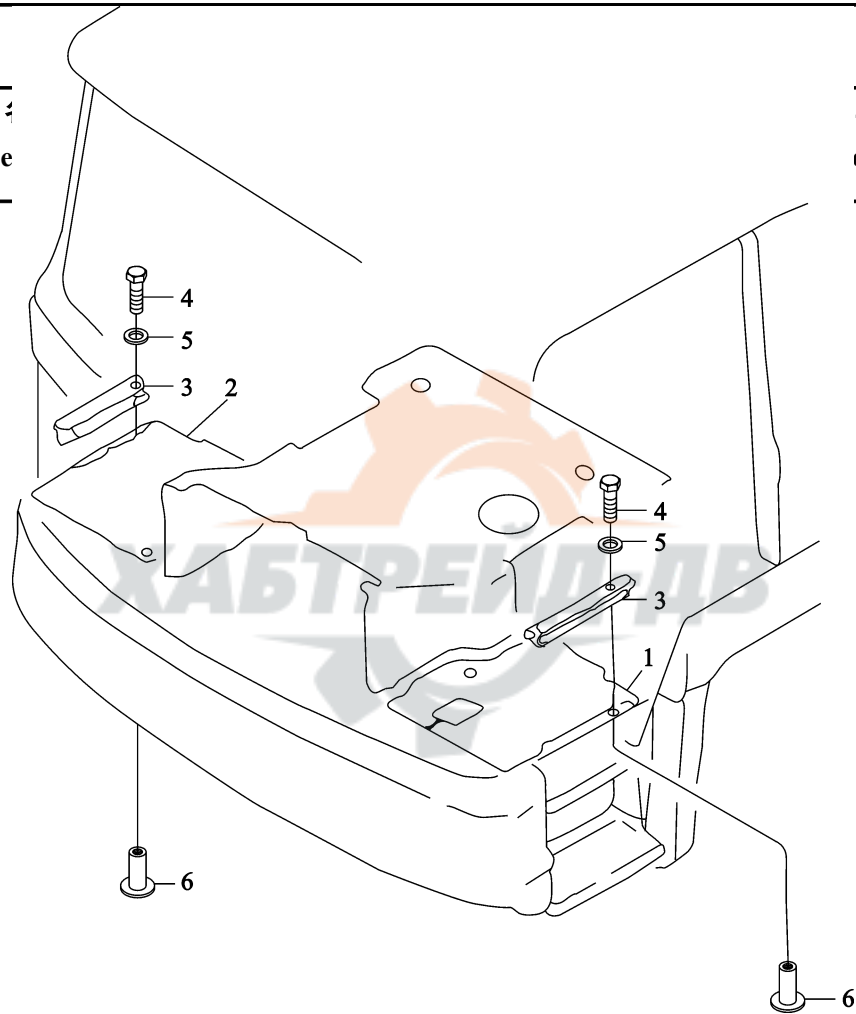

1	81.62860.0677	左前宽地板垫	Floor mat wide left	1	
	81.62860.0681	左前地板垫	Floor mat left	1	
2	81.62860.0676	右前宽地板垫	Floor mat wide right	1	右置车 to right
	81.62860.0680	右前地板垫	Floor mat right	1	
3	81.61510.0137	防滑条	Anti-skid strip	2	
4	06.04201.2607	六角头螺栓	Pan-head screw	6	右置车 to right
5	06.15191.0207	垫 片	Washer	6	
6	06.13169.0012	空单面装压铆钉	Blind rivet nut	6	M16×16Z2-4.8-H-A2R 6.4×18×1.6-140HV-MAN183-B1 AM16×13-QST36.3-A3A



# 地毯 CARPET

## 地毯 CARPET

序号	件号
NO	Part.No

备注
Remark

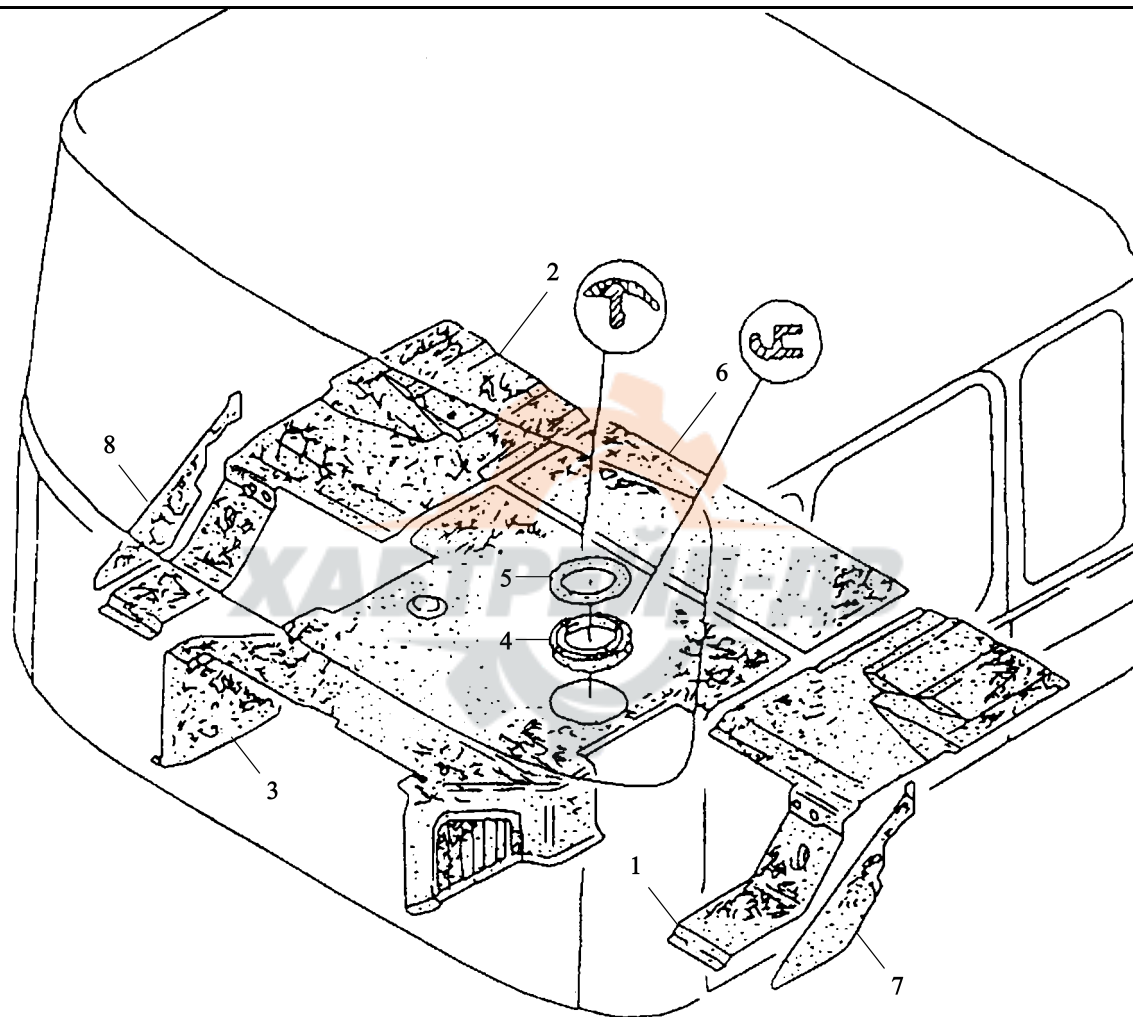

1	81.62860.0685	左后地毯	Floor mat left rear	1		
2	81.62860.0686	右后地毯	Floor mat right rear	1		
3	81.62860.6113	发动机罩衬垫	Carpet	1		
	81.62860.6114	发动机罩衬垫	Carpet	1		
4	81.62860.0410	换档杆护圈	Bordering ring	1		右置车 to right
5	81.62860.0426	装饰环	Trm ring	1		发动机罩带
6	81.62860.0694	发动机后罩垫	Engine cowlingmat f92 rear	1		发动机罩带
7	81.62860.0577	左侧围阻尼板	Side wall carpeting f90 left	1		
8	81.62860.0578	右侧围阻尼板	Side wall carpeting f90 right	1		



减振板 MELT-ON FOIL

减振板 MEL

序号 NO	件号 Part.No
----------	---------------

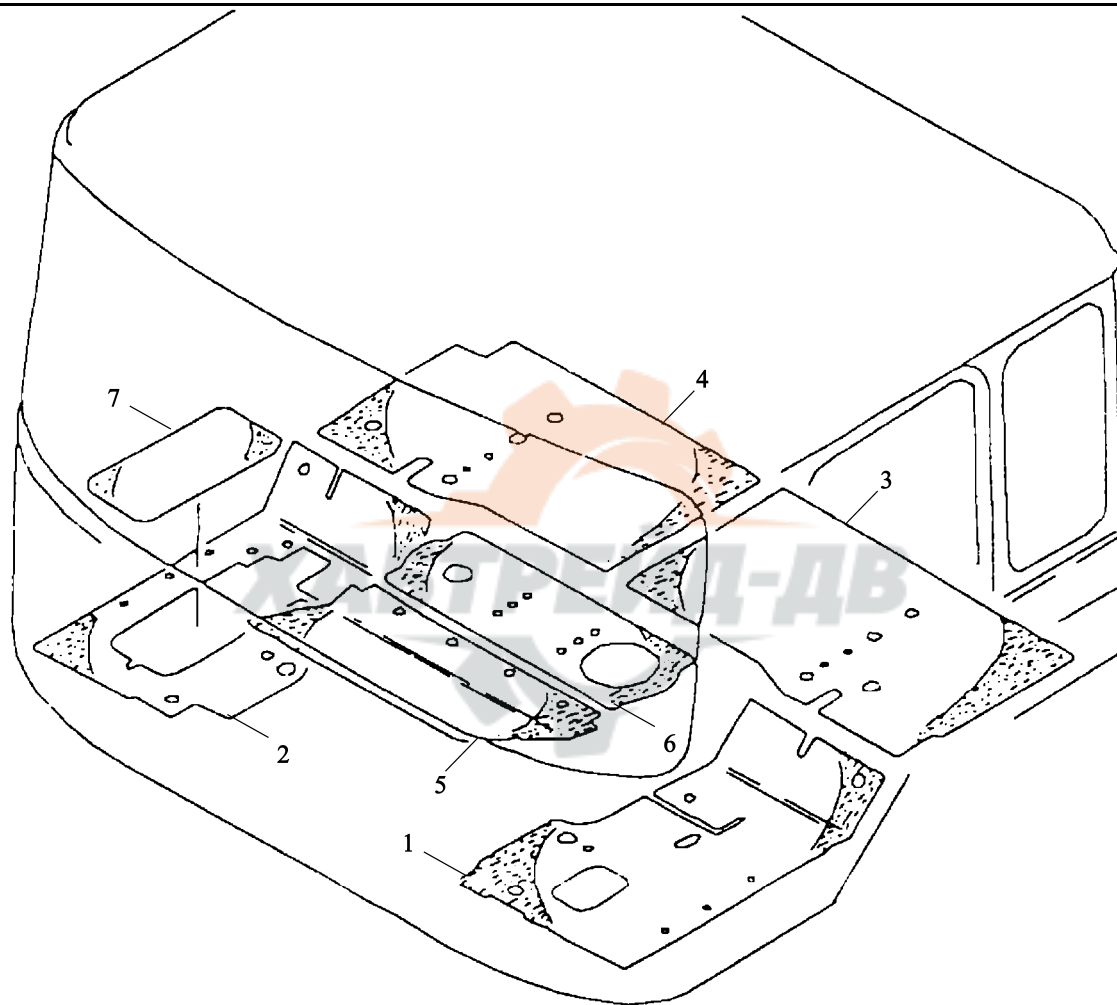

备注 Remark
--------------

1	81.62850.2215	左前减振板	melt-on foil	1		
	81.62850.2219	左前减振板	melt-on foil	1		
2	81.62850.2216	右前减振板	melt-on foil	1		用于右置车 to Right
	81.62850.2222	右前减振板	melt-on foil	1		
3	81.62850.2211	左后减振板	melt-on foil left rear	1		
4	81.62850.2212	右后减振板	melt-on foil right rear	1		用于右置车 to Right
5	81.62850.2206	前减振板	melt-on foil front	1		
6	81.62850.2207	后减振板	melt-on foil rear	1		
	81.62850.2208	后减振板	melt-on foil rear	1		
7	81.62850.2182	减振板	melt-on roil	1		
						用于右置车 to Right



隔音材料 SOUND PROOFING

隔音材料

序号 NO	件 Par
----------	----------

备注  
Remark

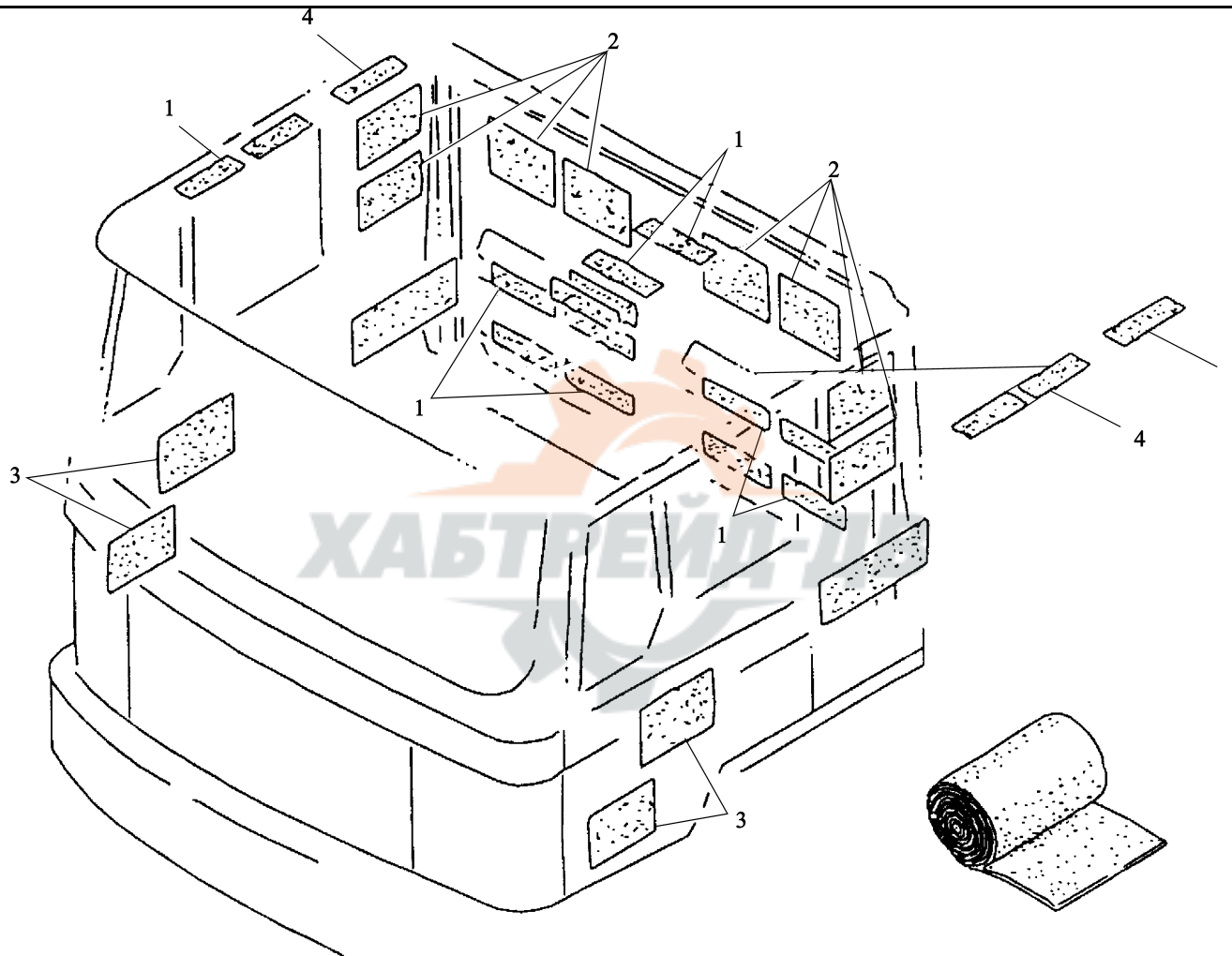



1	81.62571.2049	阻尼板	Damping plate	8		右置车 750×50×2.5
2	81.62571.2044	阻尼板	Damping plate	6		500×165×2.5
3	81.62571.2043	阻尼板	Damping plate	4		320×200×2.5
4	81.62571.2042	阻尼板	Damping plate	2		300×50×2.5



长途驾驶室隔声板 NOISE INSULATION LONG HAUL CAB

长途驾

序号
NO

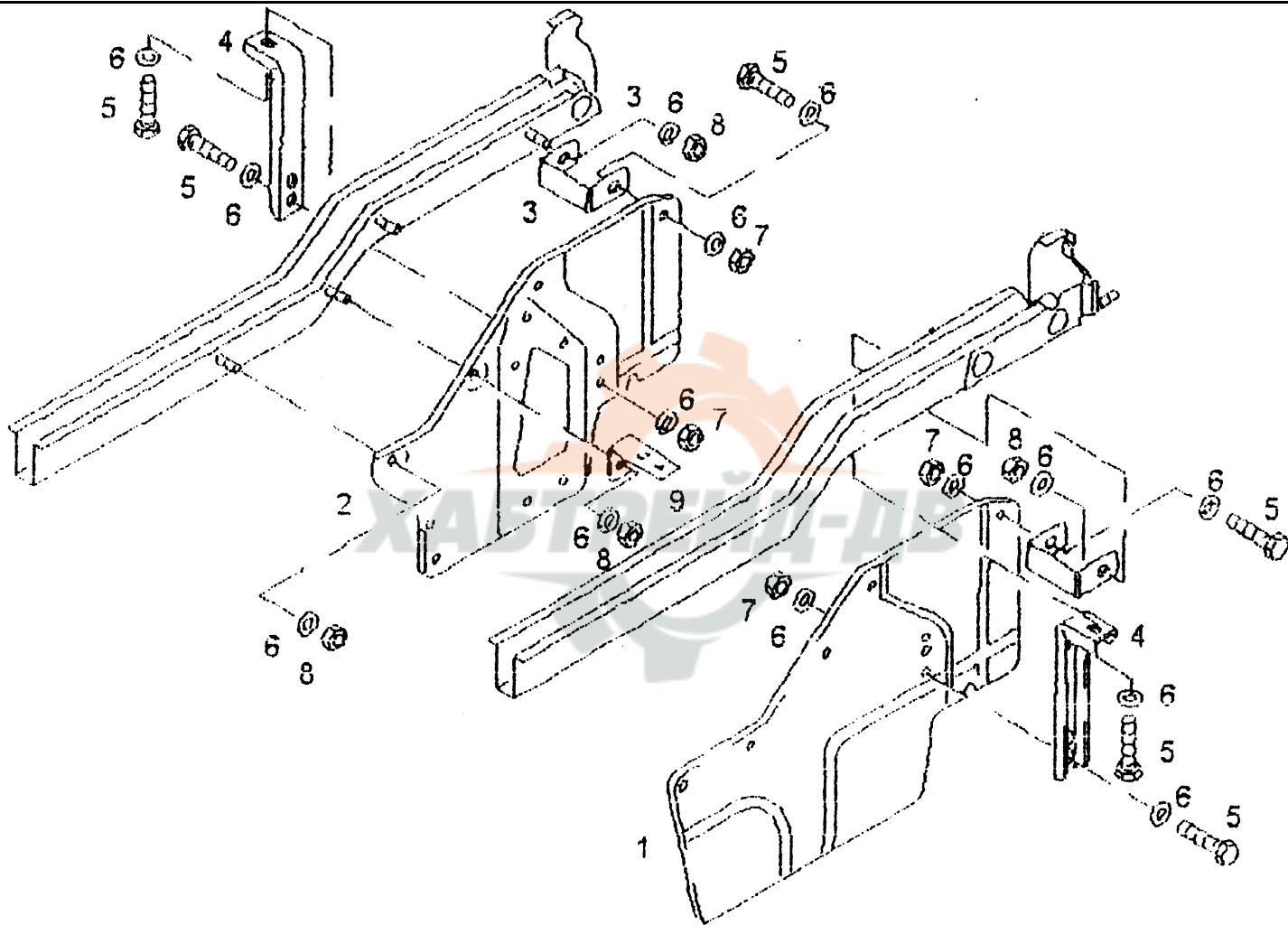

\_\_\_\_\_

rk

\_\_\_\_\_

1	81.19220.0609	左隔热板	Noise insulation	1	
	DZ1642690019	左隔热板	Noise insulation	1	
2	81.19220.6258	右隔热板	Noise insulation assy	1	
	DZ1642690018	右隔热板	Noise insulation assy	1	
3	81.19220.0118	支 架	Bracket	2	
4	81.19220.0684	支 架	Bracket right	2	
5	06.01303.3113	六角头螺栓	Hex bolt	8	M8×20SK-8.8-MAN183-A2C
6	06.15190.0309	垫 圈	Washer	20	8.4×24×2-140HV-MAN183-B1
7	06.11240.0404	自锁螺母	Hex lock nut	8	BM8-8-MAN183-B1
8	06.11069.0157	六角螺母	Hex collar nut	8	M8-8SC-8-SW13-MAN183-B1
9	81.97487.0128	连接夹	Angle	2	

帶有支座和扶手的車頂襯里

HEADLINING WITH MOUNTING AND GRAB HANDLE

帶有支座

序 号	4
NO	I

DLE

備 注

Remark

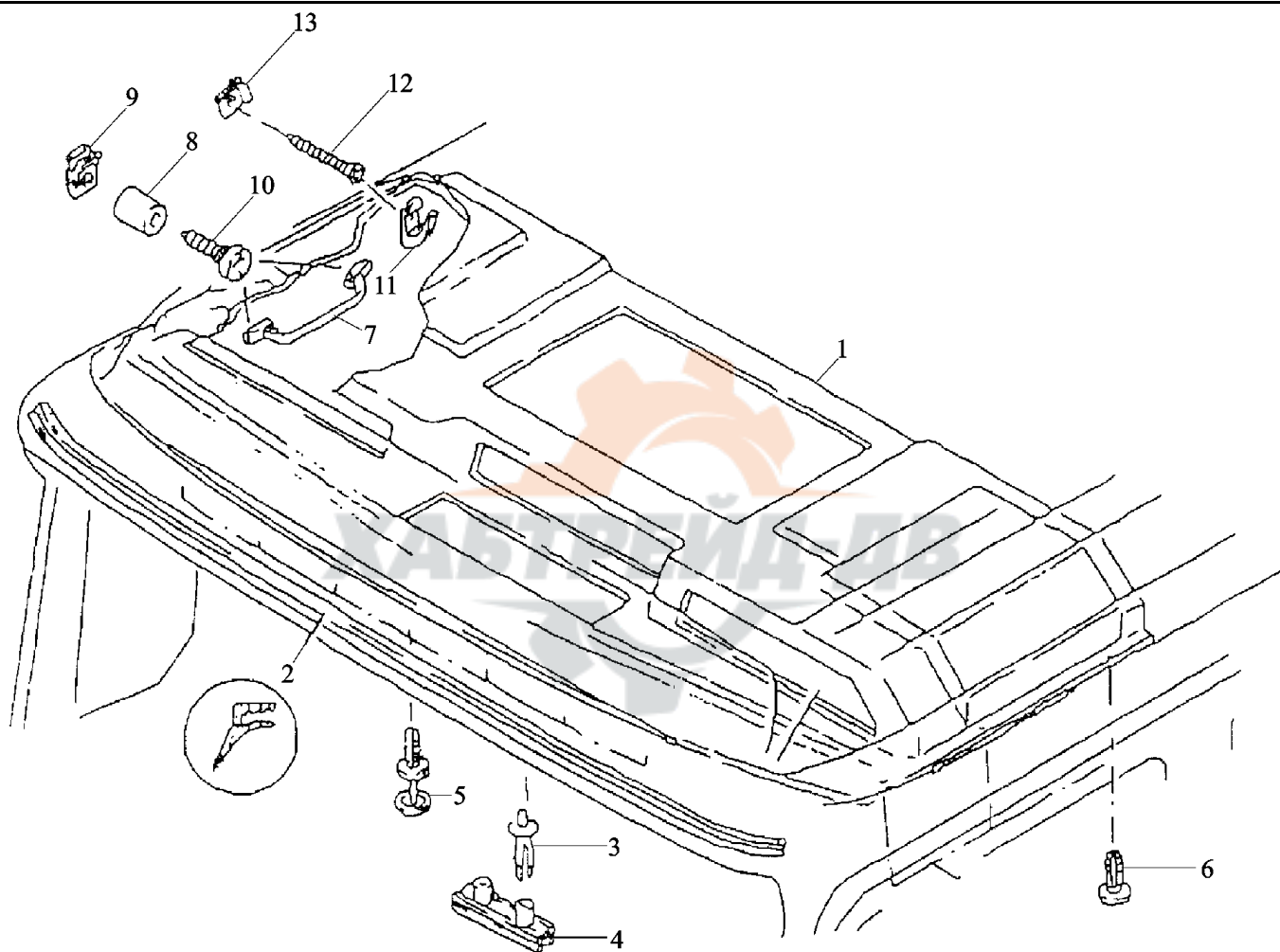

1	81.62930.5137	顶盖前衬里总成	Headlining assembly	1	
2	81.62640.0087	截面	Section	1	
3	81.63704.0012	夹片	Clamping piece	15	
4	06.04209.0028	带垫自攻螺钉	Grooved raised head coll	30	5.6×9-ST-ZN5
5	81.92202.0026	塑料开尾铆钉	Rivet	7	7.2×20/26-PA6-GR
6	06.24249.0007	铆钉	Rivet	8	7×3×17.5-4-PA6.6-SW
7	81.97001.6069	扶手总成	Grab handle assembly	1	
8	81.94289.0173	衬套	Steel tube	4	
9	06.13189.0025	簧片螺母	Speed nut	4	ST4.8-1-A3C
10	06.07156.1607	自攻螺钉	Oval-head self-tappingm	4	ST4.8×25C-HA3R
11	81.63710.0018	衣钩	screw	2	
12	06.07171.1408	椭圆头自攻螺钉	Coat hook	4	
13	06.13189.0024	簧片螺母	Oval-head self-tappingm	4	ST3.9-1-A3C
			screw		
			Speed nut		

带支座的密封侧壁板 (一)

SIDE-WALL PANELING CLOSED WITH MOUNTING I

带支座的密封

序号 NO	件号 Part.No
----------	---------------

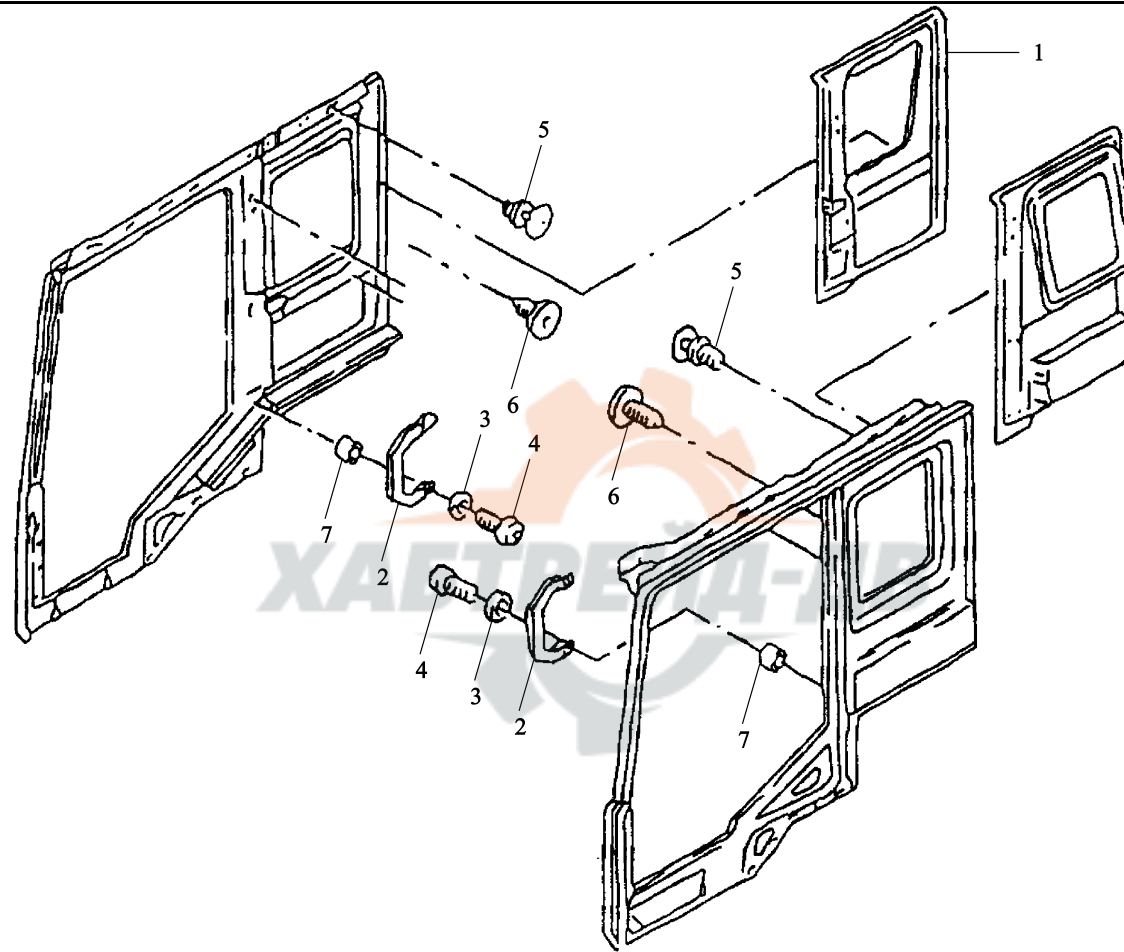

TING I

备注 Remark
--------------

1	81.62571.0036	右侧围内护面（封闭）	Interior paneling right	1		
	81.62571.0037	左侧围内护面（封闭）	Interior paneling left	2		
2	81.97001.5065	上车扶手总成	Handhold assembly rear	1		右置车 to right
3	06.15019.0069	垫 圈	Washer	4		
4	06.04209.0025	六角螺栓	Pan-head screw	4		A6.4×12×1.6-200HV-A3R
5	81.92202.0026	塑料开尾铆钉	Rivet	6		M6×30SC-4.8-H-A3R
6	81.96002.0377	塞 子	Plug	2		7.2×20/26-PA6-GR
7	81.94299.2371	钢 管	Steel tube	4		A10.4×32.5-40-PVC-GR 12×2.5×5-0.1-ST35GBK



带支座的密封侧壁板 (二)

SIDE-WALL PANELING CLOSED WITH MOUNTING II

II

带支座的密封侧壁板

序号 NO	件号 Part.No
----------	---------------

MOUNTING II

备注  
Remark

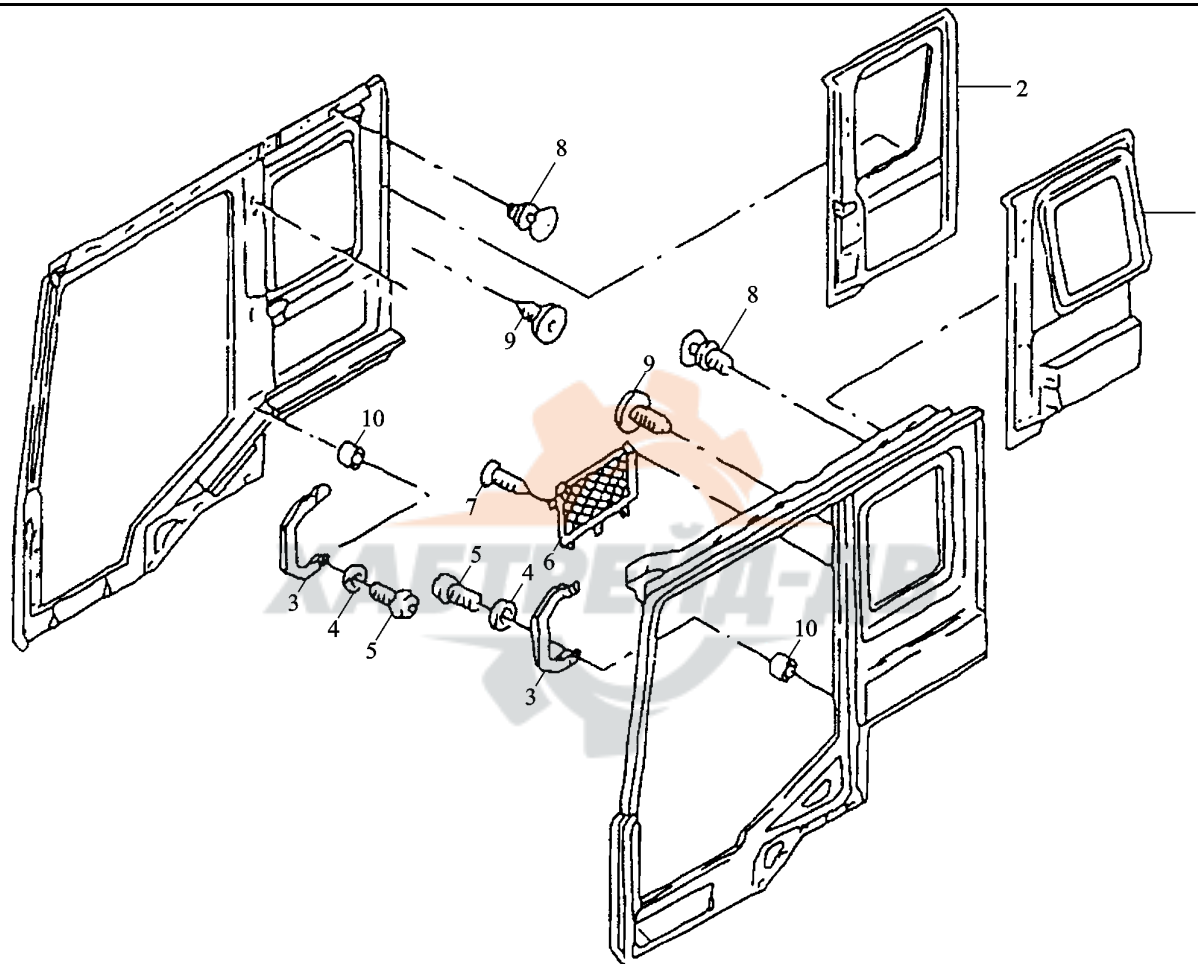



1	81.62571.0043	左侧围内护面（封闭）	Interior paneling left	1	
2	81.62571.0042	右侧围内护面（封闭）	Interior paneling right	1	右置车 to right
3	81.97001.5065	上车扶手总成	Handhold assembly rear	1	
4	06.15019.0069	垫圈	Washer	4	
5	06.04209.0025	六角螺栓	Pan-head screw	4	A6.4×12×1.6-200HV-A3R
6	81.63902.6006	网袋	Luggagae	1	M6×30SC-4.8-H-A2R
7	06.07171.1407	自攻螺钉	Self-tapping oval head	5	
8	81.92202.0026	塑料开尾铆钉	screw	6	ST3.9×25C-H-H3I
9	81.96002.0377	塞子	Rivet	2	7.2×20/26-PA6-GR
10	81.94299.2371	钢管	Plug Steel pipe	4	A10.4×32.5-5-40-PVC-GR 12×2.5×5

密封的侧栏板      SIDE PANEL CLOSED

密封的侧栏板

序号 NO	件号 Part.No
----------	---------------

备注 Remark
--------------

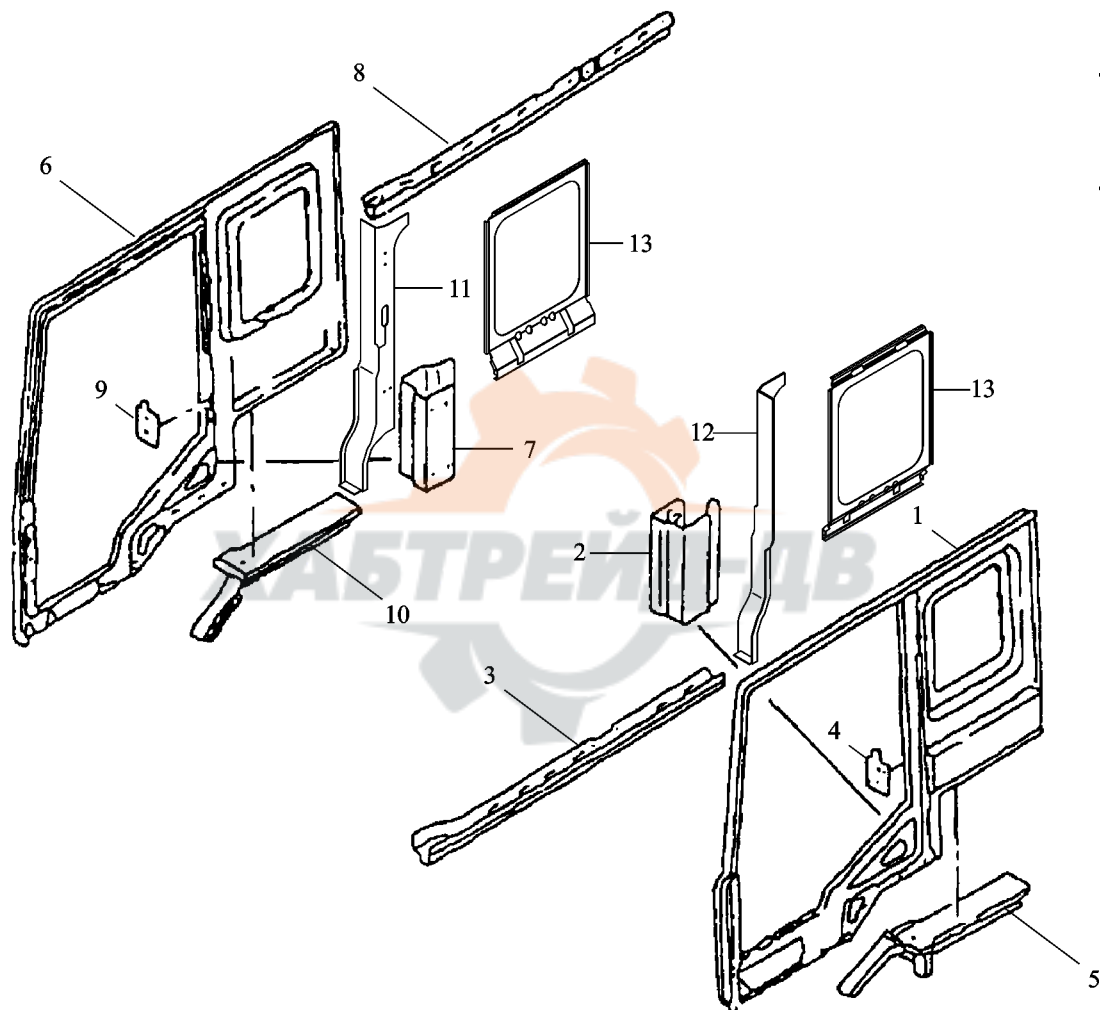

1	81.62510.2367	左侧围外板	Side panel replacement	1		
2	81.62530.4191	门立柱下加强盒	Reinforcement assembly	1		
3	81.62510.2325	左侧围上横梁	Reinforcement assembly left upper	1		
4	81.90750.0571	锁柱螺母板	Threaded plate	1		
5	81.62530.4247	左侧围下横梁总成	Reinforcement assembly left	1		
6	81.62510.2366	右侧围外板	Side panel replacement	1		
7	81.62530.4191	门立柱下加强盒	Reinforcement assembly	1		
8	81.62510.4440	右侧围上横梁总成	Reinforcement assembly right, upper	1		
9	81.90750.0571	锁柱螺母板	Threaded plate	1		
10	81.62530.4248	右侧围下横梁总成	Reinforcement assembly right	1		
11	81.62530.4199	左侧围门立柱总成	Left side panel reinforcement			
12	81.62530.4240	右侧围门立柱总成	Right side panel reinforcement			
13	81.62530.2274	侧窗内板	Side window inner plate			

车顶衬里后拦板 HEADLINING REAR PANELLING

车顶衬里后

序号 NO	件 Part
----------	-----------

备注  
Remark

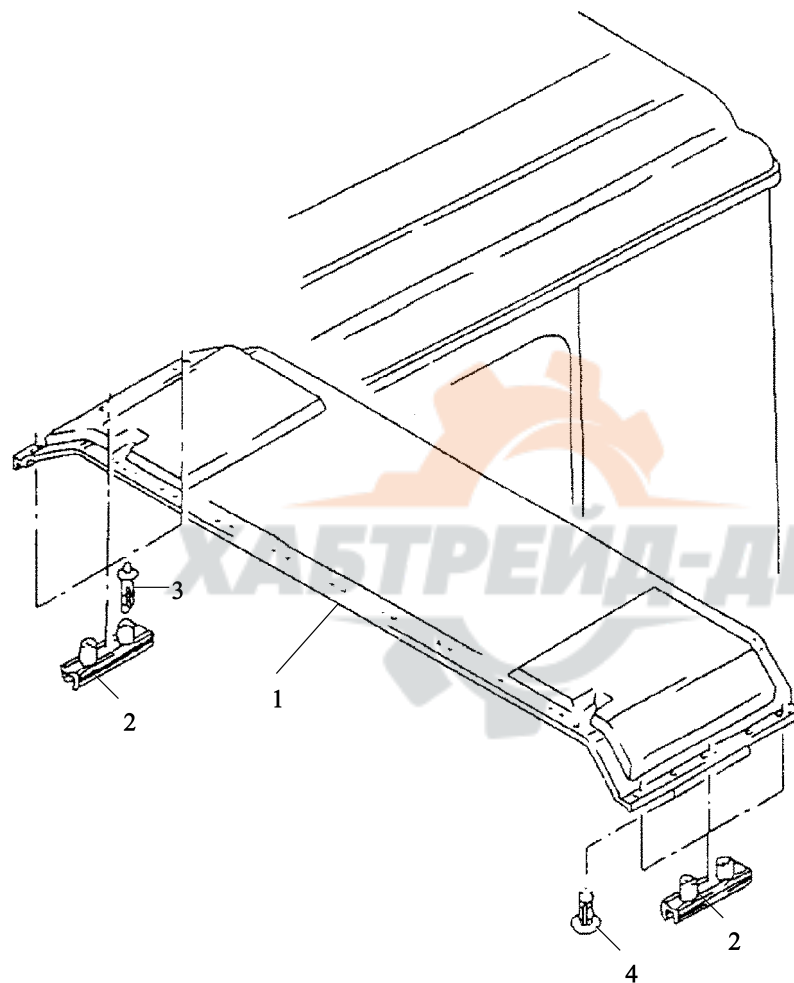

1	81.62930.5157	车顶后衬层总成	Headlining assembly	1		
2	81.63704.0012	夹 片	Clampin piece	6		
3	06.04209.0028	带垫自攻螺钉	Grooved raised head coll.screw	12		6×9-ST-ZN5
4	06.24249.0007	铆 钉	Rivet	6		7×3×17.5-4-PA6.6-SW



封闭的后围 REAR PANEL CLOSED

封闭的后围

序号 NO	件号 Part.No
----------	---------------

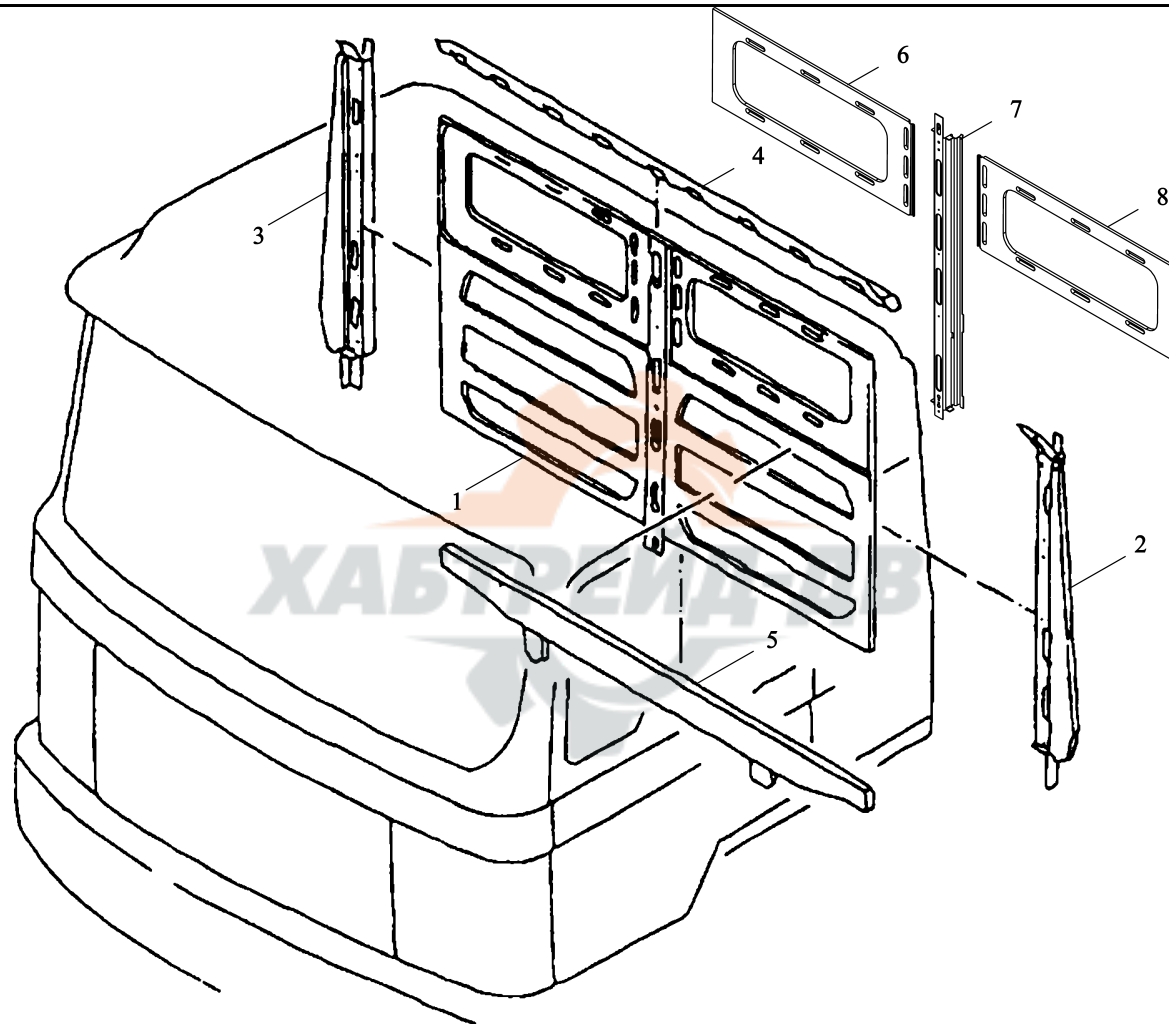

备注 Remark
--------------

1	81.62710.2285	后围外板	Rear panel replacement group	1		
2	81.62710.2279	左立柱	Rear wall reinforcement left	1		
3	81.62710.2278	右立柱	Rear wall reinforcement right	1		
4	81.62710.2241	后围上横梁	Reinforcement	1		
5	81.62710.4244	后围下横梁总成	Reinforcement assembly	1		
6	81.62730.4275	左后窗内板总成	lower	1		
7	81.62730.2542	右后窗内板总成	Rear window inner plate (left)	1		
8	81.62710.2277	中立柱	Rear window inner plate (right)	1		
			Middle column			



# 睡铺支架 SLEEPER BRACKET

## 睡铺支架

序号 NO	件号 Part.No
----------	---------------

备注 Remark
--------------

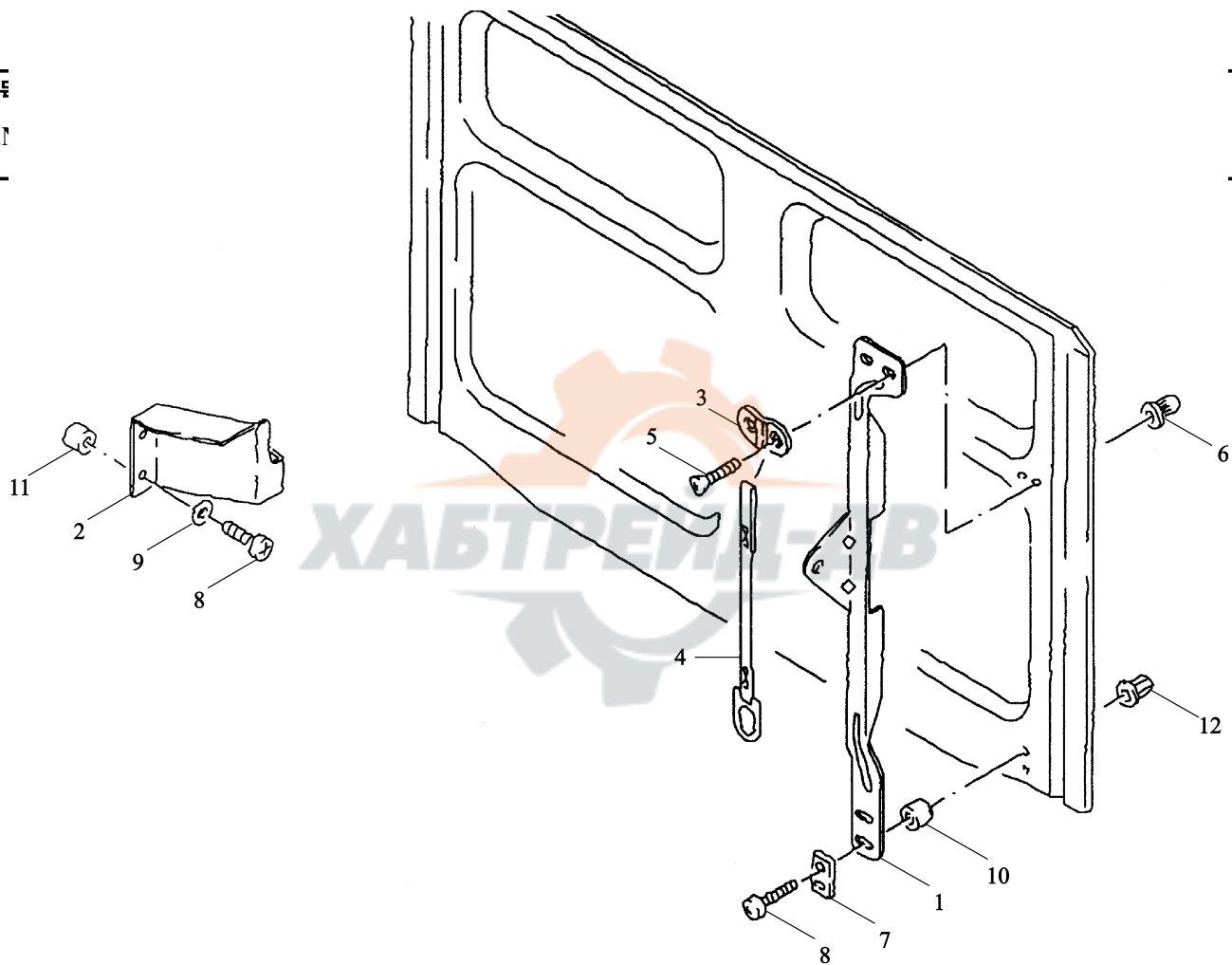



1	81.62158.0023	左支架总成	Bracket	1	
2	81.62158.0018	卧铺右支架	Support	1	
3	81.62158.0019	装配板	Securing plate	1	
4	81.62150.5033	安全带	Retaining strap assembly	1	
5	06.04300.8916	盘头螺钉	Oval-head countersunk screw	2	M8×35-4.8-H-A2R
6	06.13169.0013	铆接螺母	Blind rivet nut	4	AM8×15.5-QST36.3-A3A
7	81.97487.0494	连接板	Fish plate	1	16×3×65-12.5-40-9.0- ST37-2-A4C
8	06.04201.8713	沉头螺钉	Pan-head screw	4	M8×30-4.8-H-A2R
9	06.15019.0084	垫 圈	Washer	2	A8.4×16×1.6-200HV- MAN183-B4
10	81.94289.0163	衬 套	Steel tube	4	16×3.5×7.5-0.25-ST35BK
11	06.18610.1509	钢 管	Steel tube	2	16×3.5×9-0.2-ST35BK
12	06.13169.0011	铆接螺母	Blind rivet nut	2	AM8×28.7-ST/PUR-A3C

# 下铺支架隔板 LOWER SLEEPER BRACKET WALL

下铺支

序号

NO

k

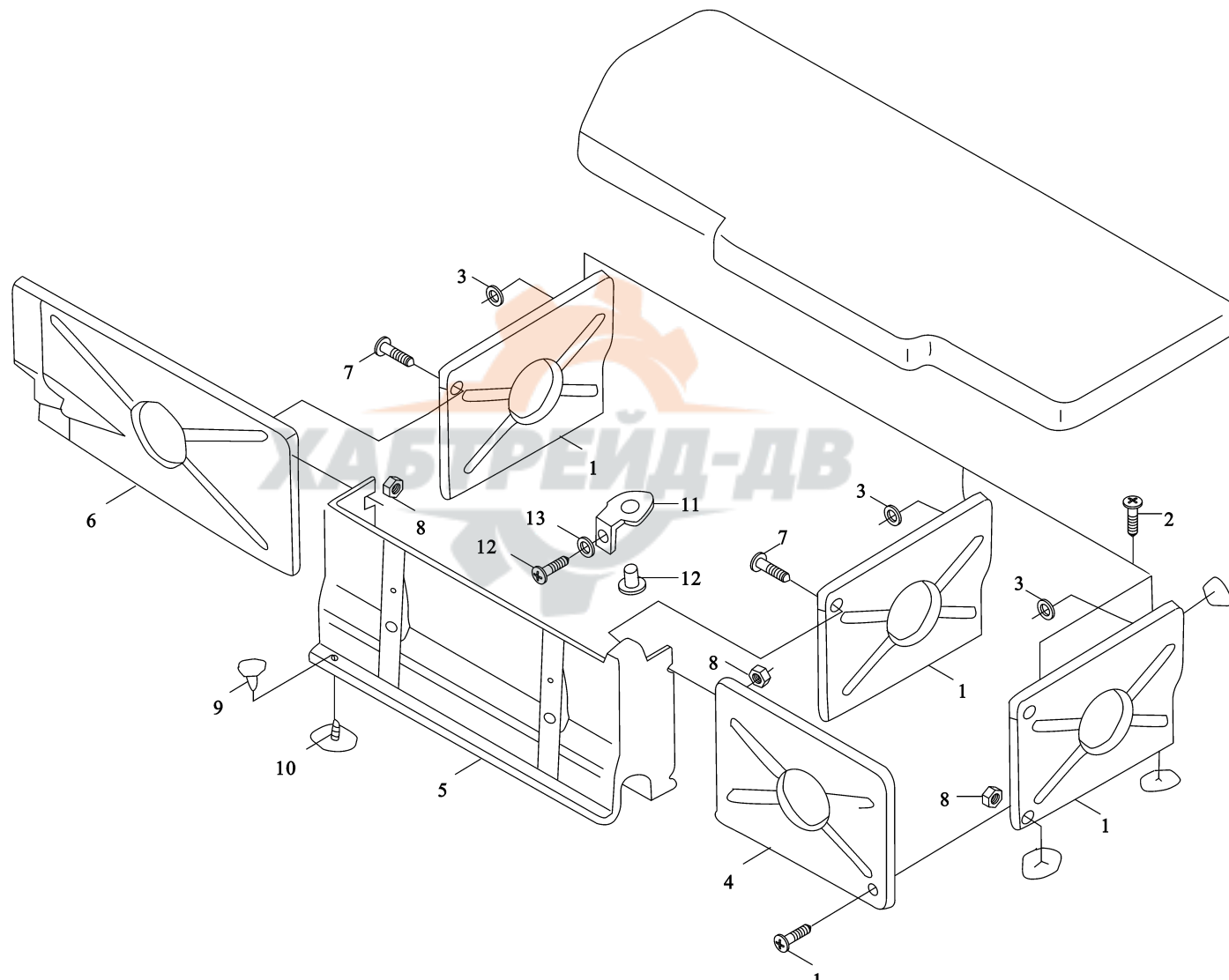

1	81.62158.0027	下铺支架隔板	Lower sleep bracket wall	3		
2	06.09093.2307	自攻螺钉	Oval head screw	4		ST4,2×38-M-H-A3R
2	06.07158.6808	自攻螺钉	Oval-head self-tapping screw	4		ST3,9×32Z2-C-H-A3R
2	06.07158.1507	自攻螺钉	Oval-head self-tapping screw	4		ST4,2×25C-H-A3R
3	06.07158.6805	自攻螺钉	Oval-head self-tapping screw	4		ST3,9×19Z2-C-H-A3R
3	06.07158.6807	自攻螺钉	Oval-head self-tapping screw	4		ST3,9×25Z2-C-H-A3R
3	06.07158.1507	自攻螺钉	Oval-head self-tapping screw	4		ST4,2×25C-H-A3R
	06.15199.0006	垫 圈	Washer	8		5,3×15×1,2-140HV-A3R
4	81.62158.0025	下卧铺左支架	Storage box wall left	1		
5	81.62158.0024	下卧铺中央支架	Stowage box center	1		
6	81.62158.0026	下卧铺右支架	Storage box wall	1		
7	81.90470.0621	自攻螺钉	Grooved raised head collscrew	9		PT-KA5×20-WN1411-109-A3R
8	81.90685.0395	螺 母	Speed nut	7		50×3,5×8-POM-BL
9	81.90685.0352	铆 钉	Sleeve nut with hexagon socket	4		B-9,3/M6/10,0-ST-SW5-A3R
10	81.91020.0748	销 钉	Pin	1		
11	81.91605.0040	固定板	Securing plate	1		
12	06.04201.8509	盘头螺钉	Pan-head screw	2		M5×20-4,8-H-A2R
13	06.15019.0072	垫 圈	Washer	2		A5,3×10×1-200HV-A3R

# 下铺 LOWER SLEEPER

下铺	L
序号	
NO	

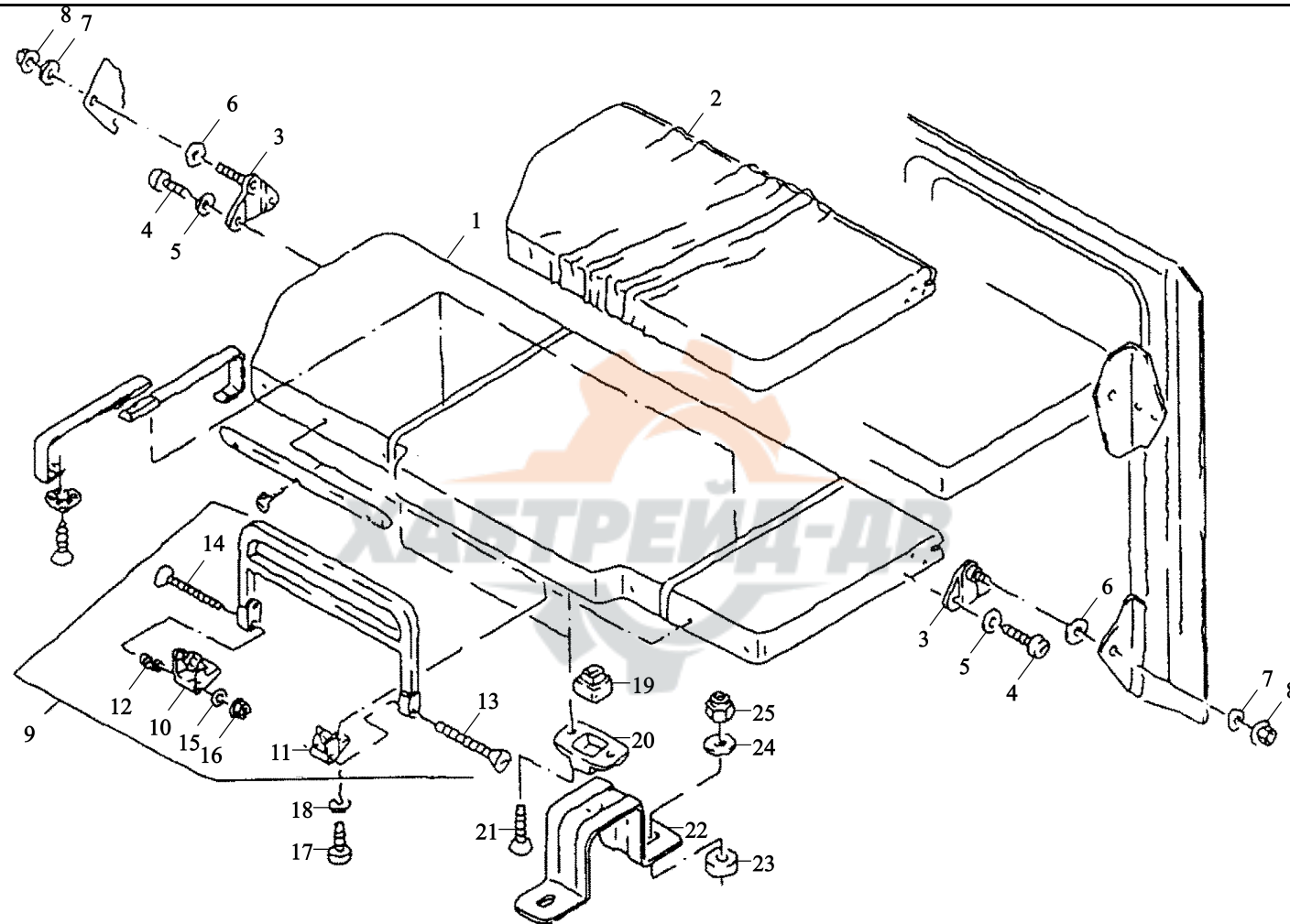

注  
emark

	DZ1643370030	卧铺总成	bunk assembly	1		
1	81.62159.6268	卧铺总成	bunk assembly	1		
2	81.62160.5143	卧铺垫总成	covering assembly	1		
3	81.62159.5229	板总成	plate assembly	2		
4	06.04209.0030	平头螺钉	pan-head screw	4		M8×16-4.8-H-A3R
5	06.15019.0084	垫 片	washer	4		A8.4×16×1.6-200HV- MAN183-B4
6	81.90713.0004	垫 片	washer	2		12.5×25×2.5
7	06.15019.0084	垫 片	washer	2		A8.4×16×1.6-200HV- MAN183-B4
8	06.11240.0604	六角锁紧螺母	hex lock nut	2		BM8-8-MAN184-B4
9	81.62150.6017	保护架总成	securing clip assembly	1		
10	81.62150.6016	锁止架总成	retainer, left assembly	1		
11	81.62150.0023	安全装置轴承支架	bracket	1		
12	06.46080.0340	压缩弹簧	pressure spring	2		2.5×12.5×47.5
13	06.04299.0009	沉头螺钉	countersunk screw	1		M8×90×34-4
14	06.04299.0010	沉头螺钉	countersunk screw	1		M8×100×34-4
15	06.15019.0084	垫 片	washer	2		A8.4×16×1.6-200HV- MAN183-B4
16	06.11240.0604	六角锁紧螺母	hex lock nut	2		BM8-8-MAN183-B4
17	06.04209.0030	盘头螺钉	pan-head screw	6		M8×16-4.8-H-A3R
18	06.15019.0084	垫 片	washer	6		A8.4×16×1.6-200HV- MAN183-B4
19	81.96020.0129	橡胶垫	rubber pad	2		26.5×29.5×19-8

# 下铺 LOWER SLEEPER

下铺 L  
 序号 NO

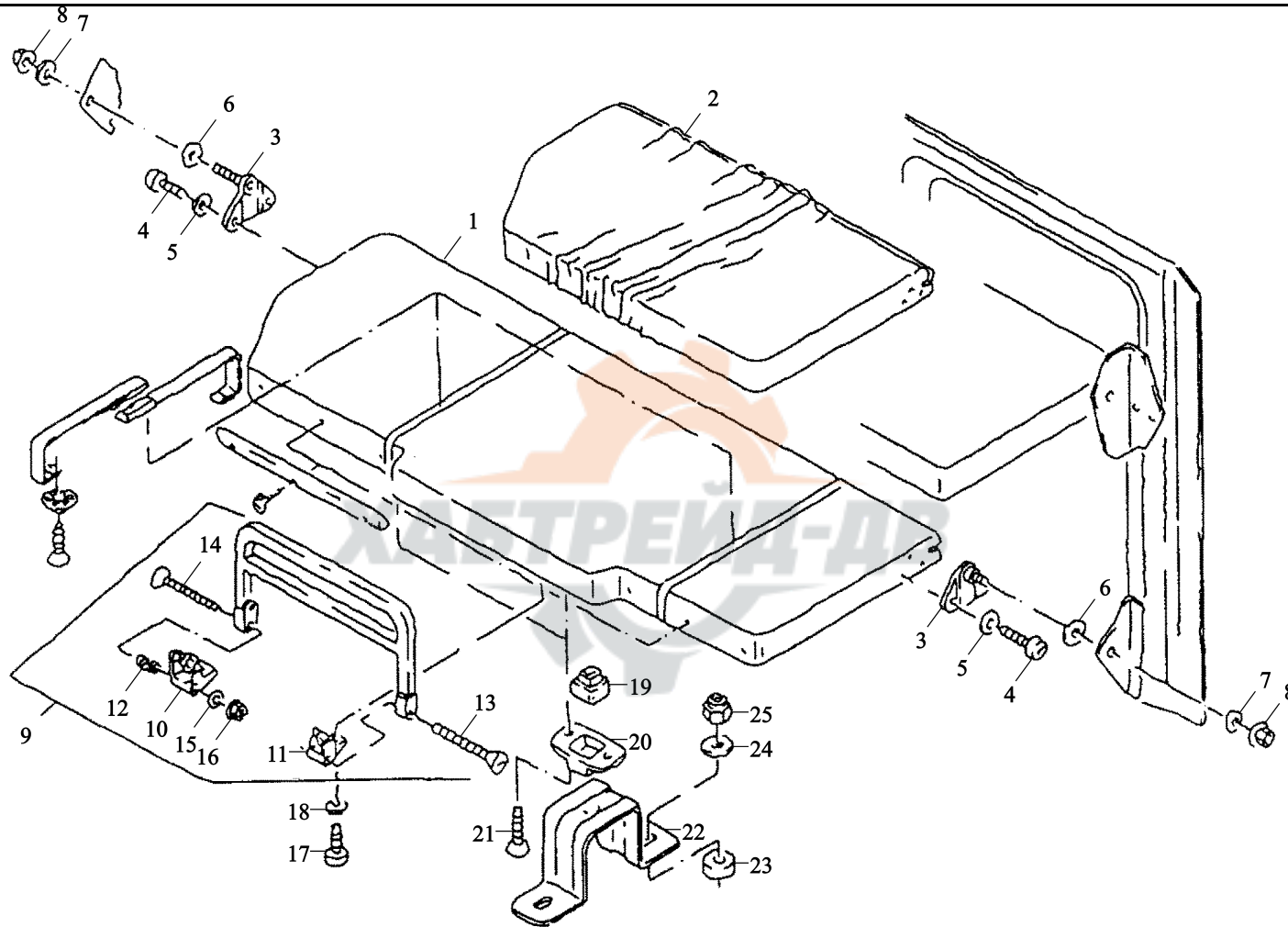

注  
 Remark

21	06.04209.0023	盘头螺钉	pan-head screw	4		M5×16-4.8-H-A3R
22	81.62158.5010	支架总成	bracket assembly	2		
23	88.90710.0070	垫 片	washer	4		6.5×20×7-ST52-3-A3C
24	06.15190.0407	垫 片	washer	4		6.4×18×1.6-140HV-A3R
25	06.12079.0003	六角锁紧螺母	hex cap lock nut	4		M6-6-A3R



上铺装置 UPPER SLEEPER EQUIPMENT

上  
序

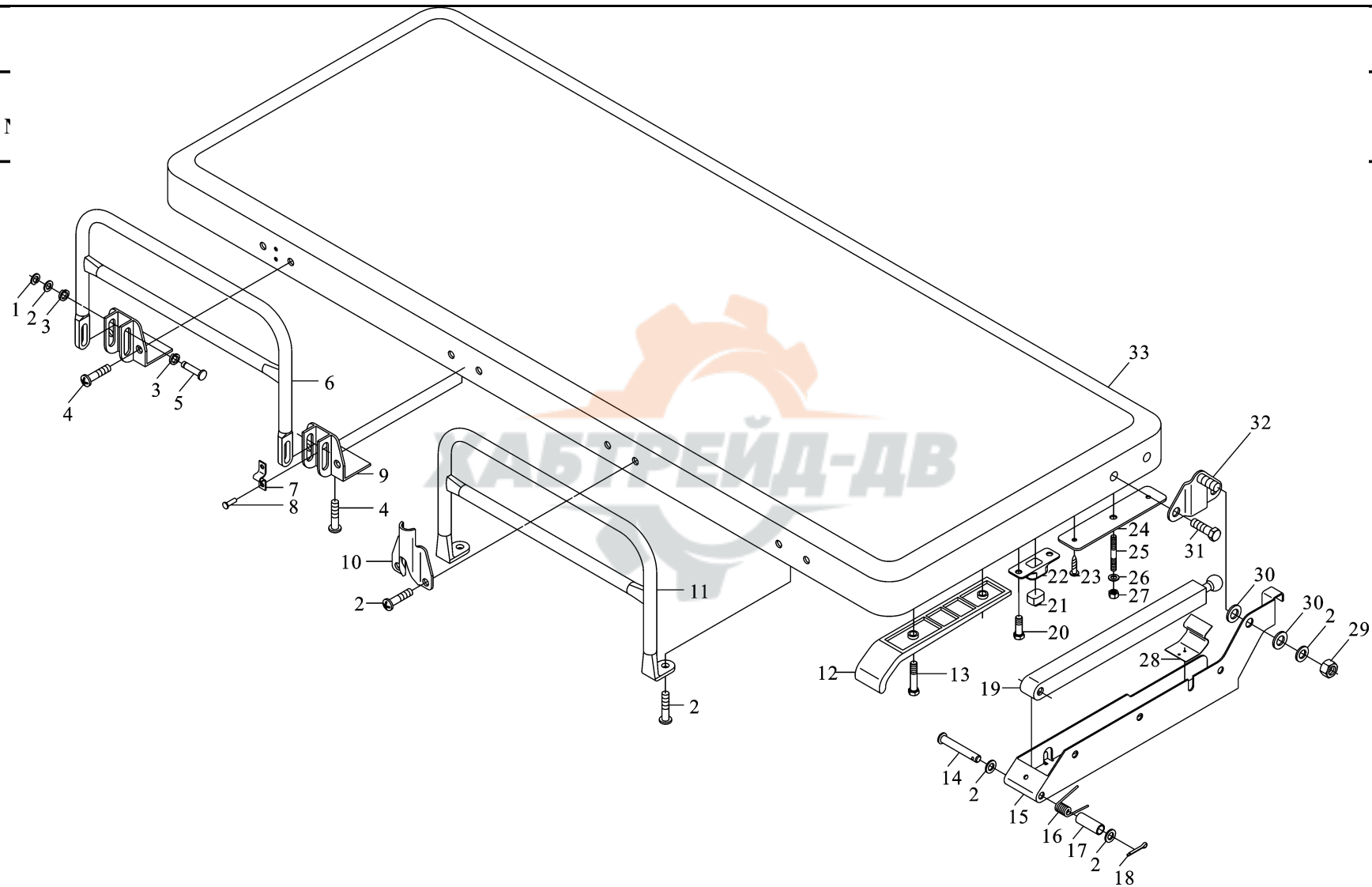



	81.62159.6261	上□ 裝置	Upper sleeper equipment		
1	06.29050.0110	□ 用□ 性□ 圈	Circlip	2	7-ZNPHR3F
2	06.15019.0084	□ 圈 □	Washer	8	A8.4-200HV-A3R
3	81.90712.0815	□ 圈 □	Washer	4	8.5×16×2-PA6
4	06.04201.8709	十字□ □ 螺□	Hex screw	12	M8×20-4.8-HA3Q
5	81.91020.0743	□ □	Pin	2	
6	81.62150.6015	活□ □ □	Active protect fence	1	
7	81.97651.0148	簧 片	Spring	2	
8	06.24041.0406	□ □	Rivet	4	2×8-UST36-2
9	81.62150.2060	活□ □ □ 支架	Bracket	2	
10	81.62150.0027	□ □ 板	Fastening plate	2	
11	81.62150.5030	固定□ □	Fixation protect fence	1	
12	81.62159.0193	□ 盖 □	Protect cap	2	
13	06.04201.2509	螺 □	Screw	4	M5×20
14	06.21569.0149	□ □	Pin	2	B8H11×75×71.5-CQ15K-A3R
15	81.62159.5278	左□ □ 支架	Sleeper bracket left	1	
	81.62159.2468	右□ □ 支架	Sleeper bracket right	1	
16	81.97630.0174	□ 簧 □	Spring	2	
17	81.93030.0198	□ 套 □	Bush	2	
18	06.16029.0035	□ □ □	Cotter pin	2	
19	81.62159.5277	撑 杆	Rod	2	
20	06.04300.8707	螺 □	Screw	4	M5×12-4.8-H-A2R
21	81.96020.0129	橡胶□	Rubber cushion	2	
22	81.62159.0153	胶□ 座	Cushion seat	2	
23	06.07158.1503	自攻螺□	screw	4	ST4.2×13-C-H-A3R

上铺装置 UPPER SLEEPER EQUIPMENT

上  
序

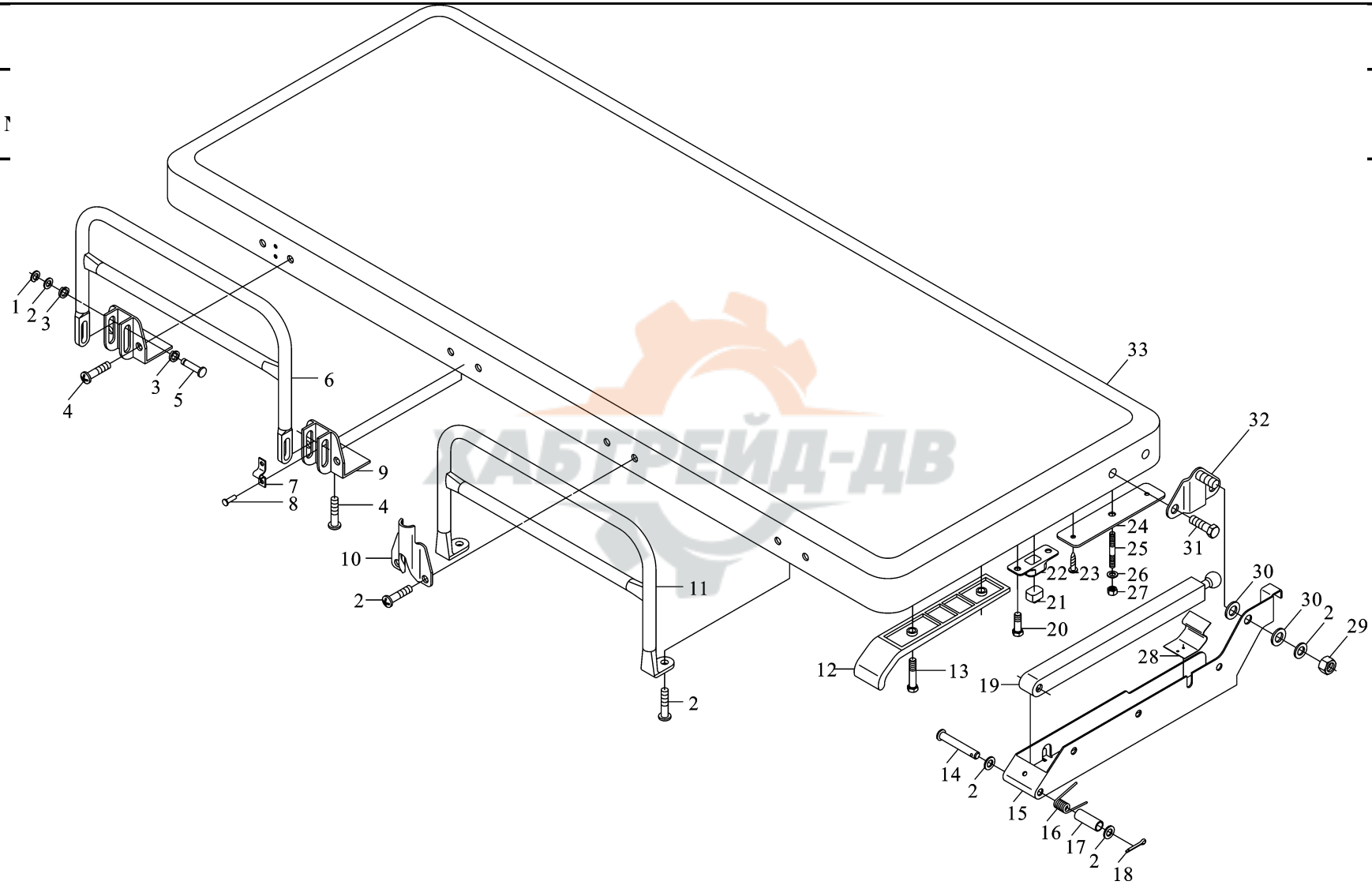

24	81.62159.2470	固定板	Fixation plate	2		
25	06.06156.0515	双□ 螺柱	Stud	2		M8×40-45H
26	06.15019.0084	□ 圈 □	Washer	2		A8.4-200HV-A3R
27	06.11064.2114	六角螺母	Hex nut	2		BM8-04-A2C
28	81.97651.0147	卡 簧	Circlip	2		BM8-8-A2R
29	06.11240.0604	六角螺母	Hex nut	2		
30	81.90713.0004	塑料□ 片	Plastic sheet	4		
31	06.04209.0030	十字槽□ □ 螺□	Screw	4		M8×16-4.8-H-A2R
32	81.62159.5229	板□ 成	Plate	2		
33	81.62159.6259	□ □ □ 成	Sleeper assy	1		



# 密封的后围板 REAR WALL PANELLING CLOSED

密封的

序号
NO

注  
ark

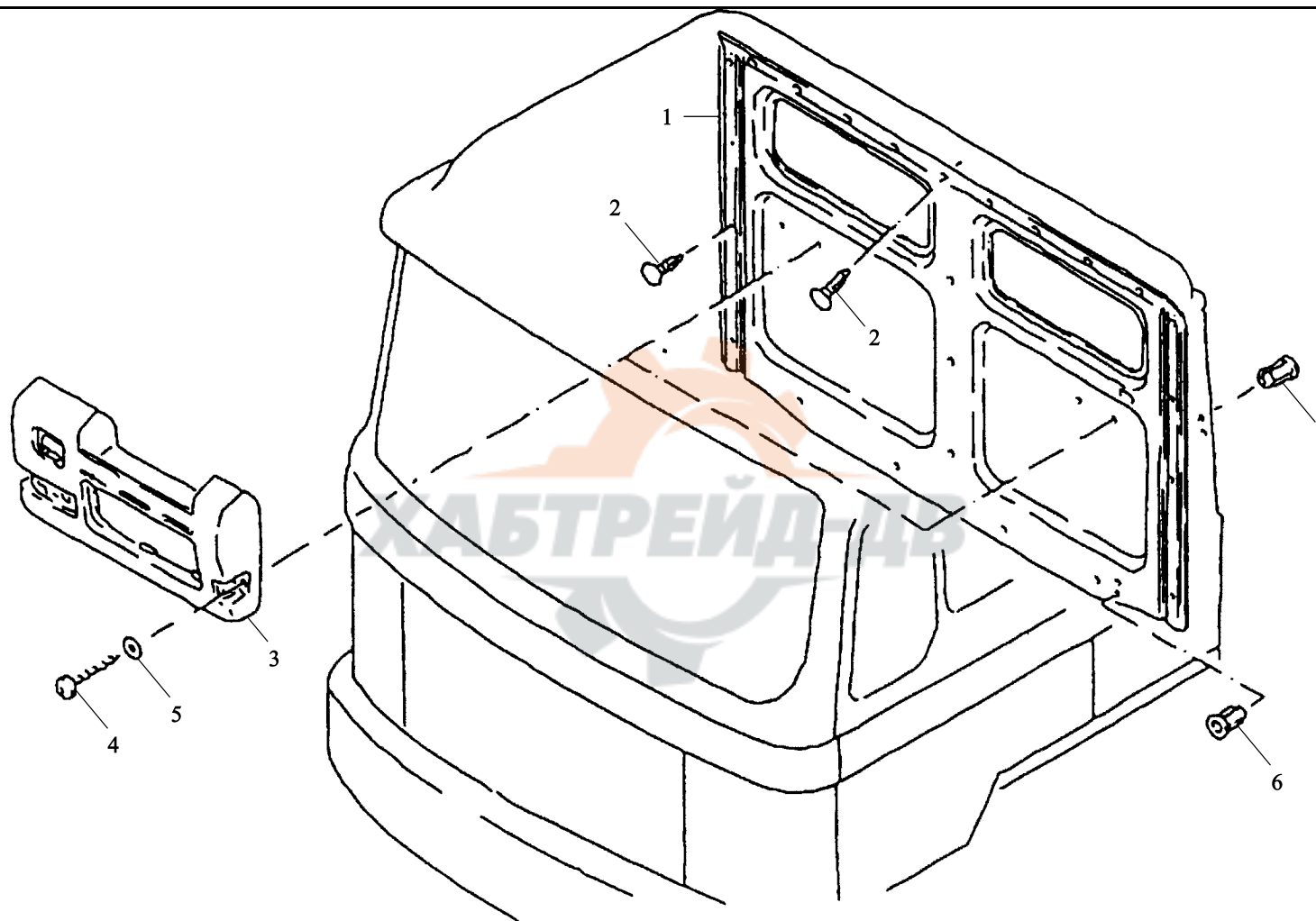

1	81.62770.0100	加宽驾驶室后围内饰板	Widen cab rear wall	1		封闭式
2	81.92202.0026	铆 钉	Rivet	19		7.2×20/26-PA6-GR
3	81.62740.0067	驾驶室后围照明灯柜架	Adapter	1		高顶
4	06.07158.1409	椭圆头自攻螺钉	Oval-head self-tapping	2		ST9×38C-J-A3R
5	06.15013.0065	垫 片	screw	2		A4.3×9×0.8-200HV-
			Washer			MAN183-B1
6	06.13169.0011	空心铆钉六角螺母	Blind rivet nut with hexagon	8		AM8×28.7-ST/PUR-A3C

座椅底座盖板 COVERING SEAT BOX

座椅底座盖板

序号 NO	件号 Part.No

备注 Remark

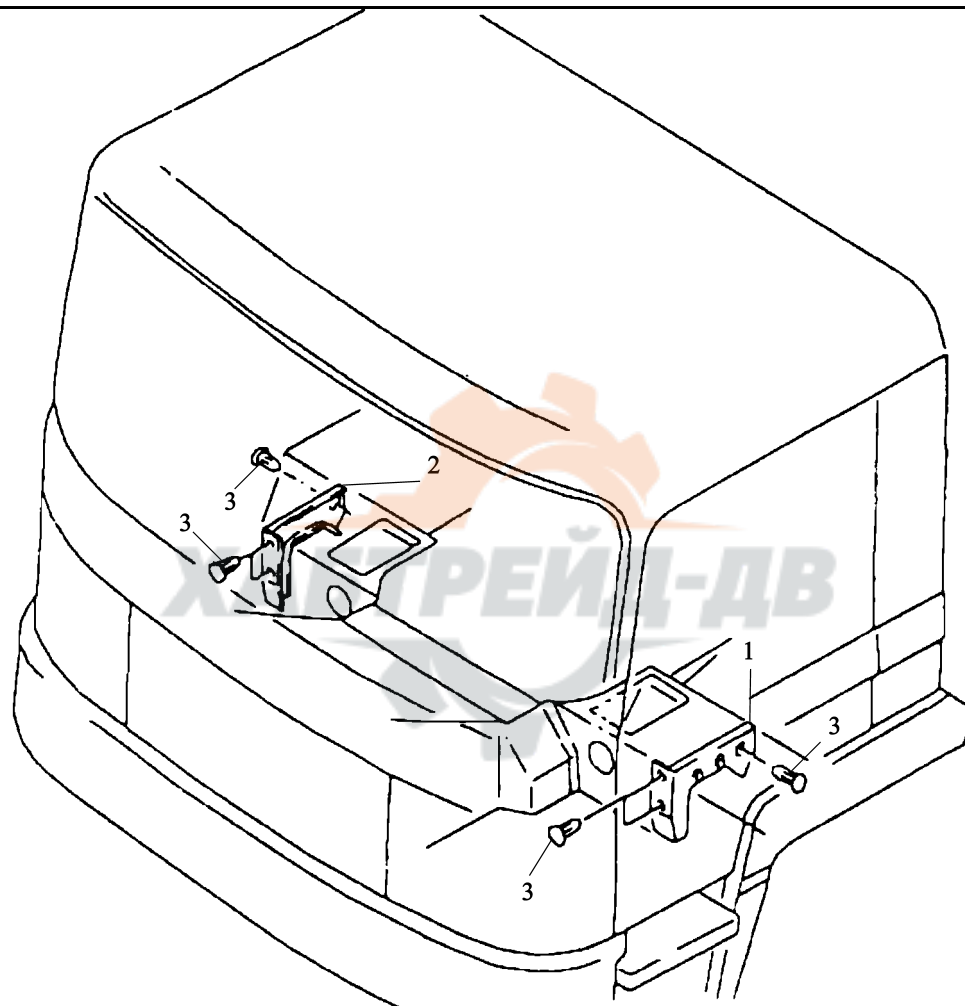

1	81.62230.0039	护盖左	covering left	1		
2	81.62230.0040	护盖右	covering right	1		
3	81.92201.0093	铆 钉	rivet	6		6.2×14.8-POM-RAL9011



左空气弹簧座椅 SEAT LEFT AIR SPRING

左空气弹簧座椅 SEAT LE

序号 NO	件号 Part.No	名称 Designation
----------	---------------	-------------------

适用车型 Suited type	备注 Remark
---------------------	--------------

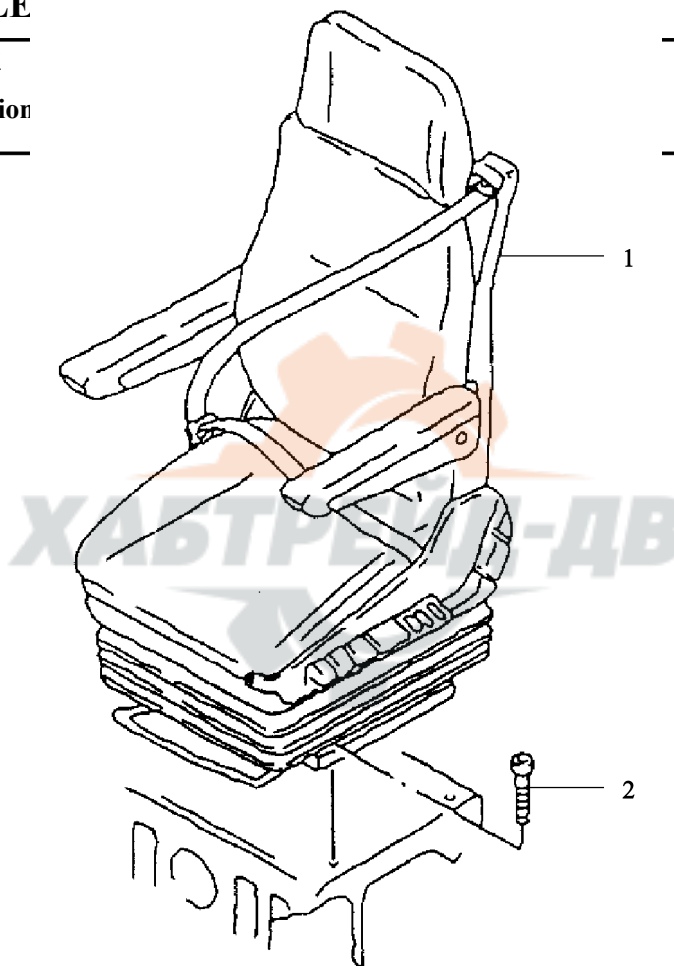



1	81.62301.6895	左座椅总成	Seat air spring left	1	豪华型 豪华型	
	81.62301.6896	右座椅总成	Seat air spring right	1		用于右置车 to right
	81.62301.0050	右座椅总成	Seat air spring right	1		
	DZ1643510030	液压式左座椅总成	Hydraulic seat assy left	1		用于右置车 to right
	DZ1600516210	左座椅总成	Left seat assy	1		
	81.62301.6899	左固定座椅总成	Left fixation seat assy	1		
	DZ1643510060	左座椅总成	Seat air spring left	1		用于右置车 to right
2	06.02109.0045	螺 钉	Cylinder screw	4		用于右置车 to right
						用于右置车 to right
						用于右置车 to right M8×25SC-8.8-MAN183-B1

右固定座椅

SEAT RIGHT STATIC

右固定座椅

序号	件
NO	Part

备注  
Remark

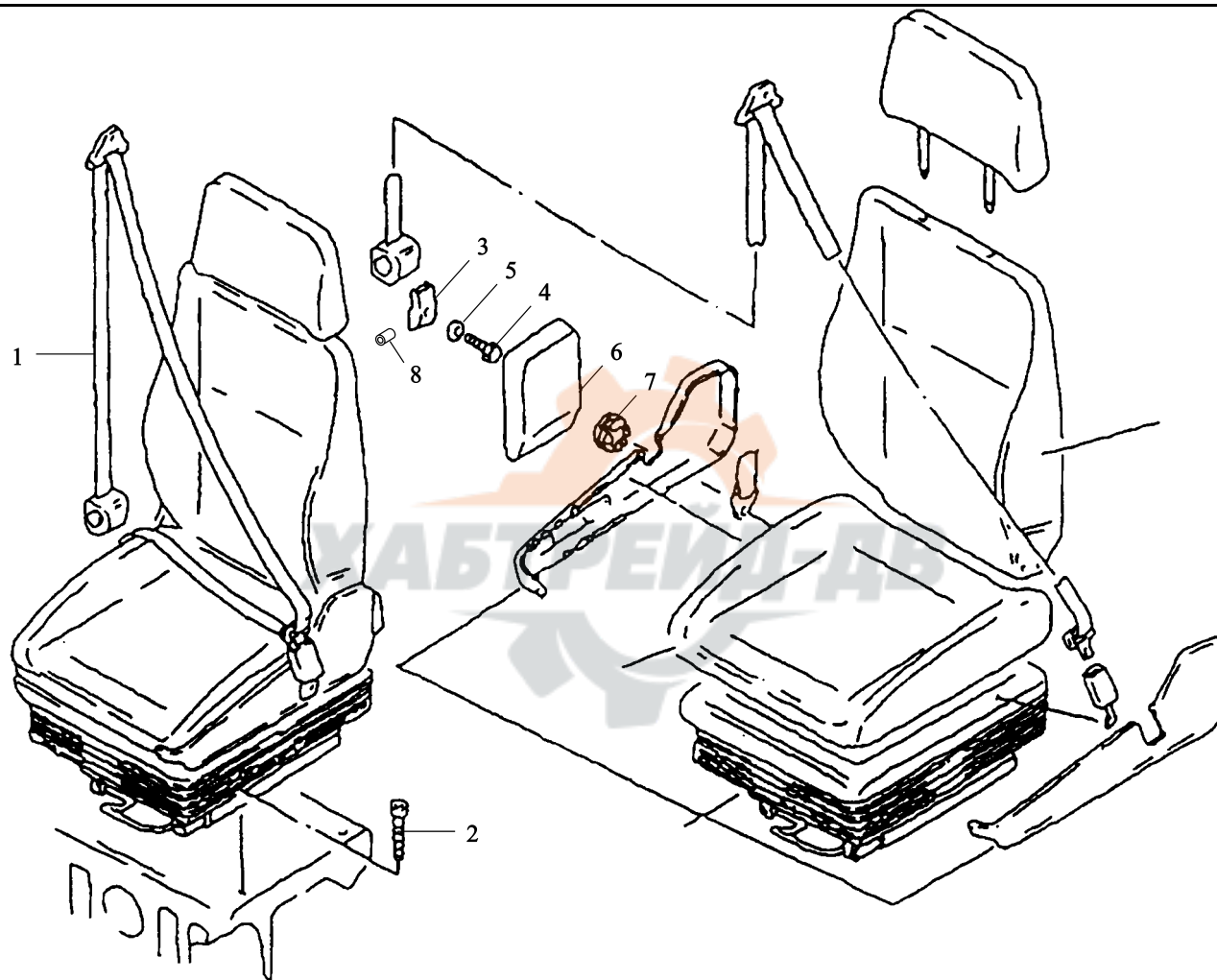

1	81.62301.6900	右固定座椅总成	Seat static right	1		
	81.62301.6896	右座椅总成	Seat static right	1		
2	06.02109.0045	螺 钉	Cylinder screw	4		用于右置车 to right
3	81.62305.0027	支 架	Bracket	1		M8×25SSC-8.8-MAN183-B1
4	06.01489.0055	六角螺栓	Hex bolt	2		
5	81.90712.0970	垫 片	Washer	2		7/16"-20UNFX22-8.8-SW17-
6	81.62305.0026	盖	Covering	1		A2C
7	81.62340.0117	帽	Cap	1		11.5×21×2-ST2K50-A3C
8	81.94299.2371	钢 管	Steel pipe	2		



左车门止动器和车门操作系统

DOOR ARRESTOR AND DOOR ACTUATING SYSTEM LEFT

左车门

序号
NO

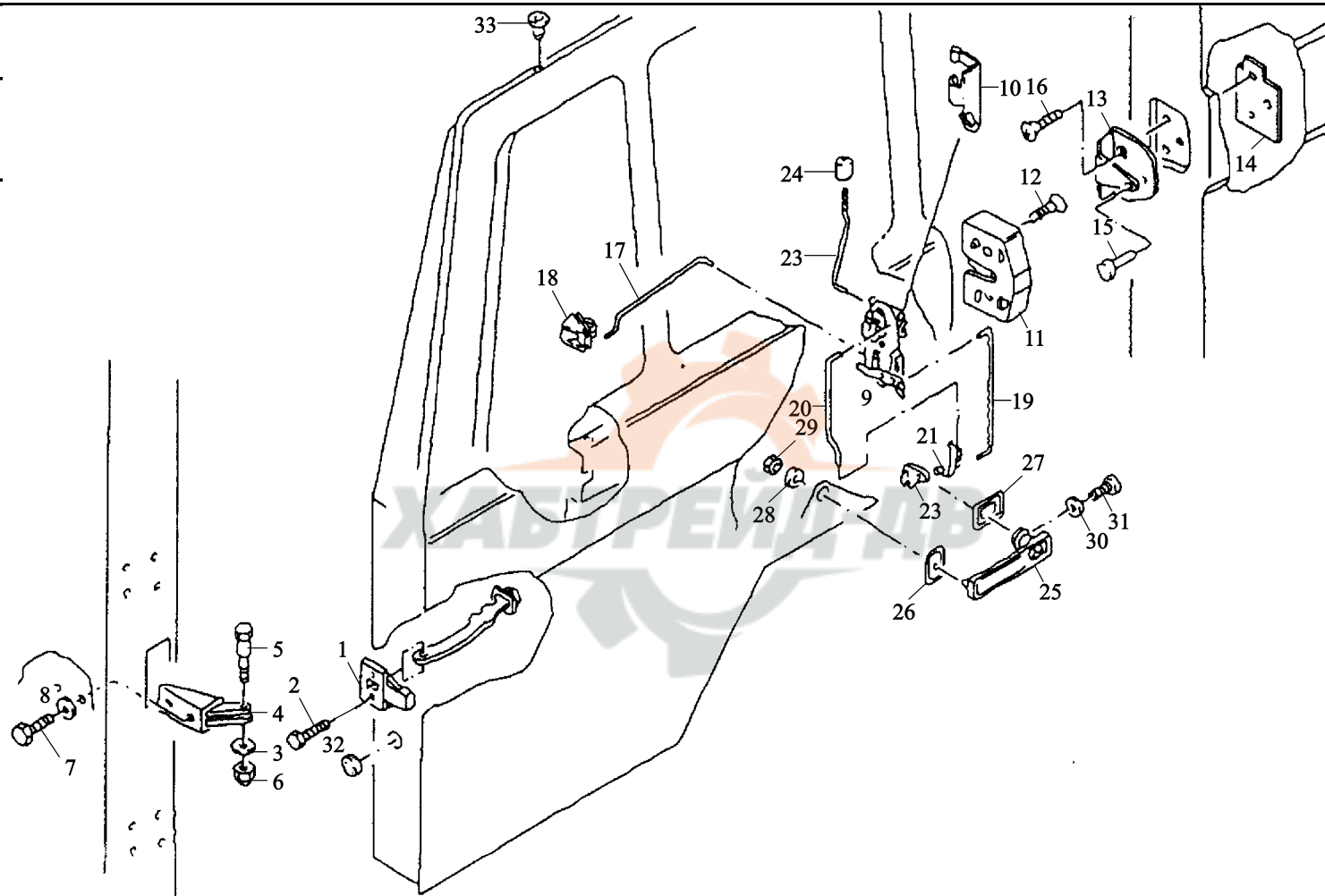

IM LEFT

rk

1	81.62670.6011	车门止动器总成	Door arrestor assembly	1	
2	06.01470.0409	六角头带垫螺栓	Hex bolt	2	M6×16
3	06.15013.6109	平垫圈	Washer	20	A6.4×12×1.6-200HV- MAN183-B1
4	81.62692.5001	支座总成	Support assembly	1	
5	81.62691.0010	螺 钉	Screw	1	
6	06.12072.0153	锁紧螺母	Hex cap lock nut	1	
7	06.01303.3113	六角螺栓	Hex bolt	2	
8	06.15013.6111	垫 片	Washer	2	A8.4×16×1.6-200HV- MAN183-B1
9	DZ16.4334.003	左车门锁总成	Door lock assembly left	1	
10	0	绿夹子	Clip green	4	
11	81.62680.0069	左锁块	Lock assembly	1	
12	81.62680.6095 06.02829.0009	锁紧螺钉	Raised counters head locking screw	2	
13		碰 板	Striker plate	1	
14	81.62680.0055	锁柱螺母板	Threaded plate	1	
15	81.90750.0571	销 子	Pin	1	
16	81.62680.0070	沉头螺钉	Oval-head countersunk screw	2	
17	06.04308.0909	左操纵杆	Operating rod left	1	
18	81.62680.0085	导 板	Guide plate	1	
19	81.62680.0083	操纵杆（四）	Operating rod	1	
20	81.62680.0074	操纵杆（三）	Operating rod	1	
21	81.62680.0073	绿夹子	Clip green	1	
22	81.62680.0069	左支架总成	Lever assembly	1	

左车门止动器和车门操作系统

DOOR ARRESTOR AND DOOR ACTUATING SYSTEM LEFT

左车门

序号
NO

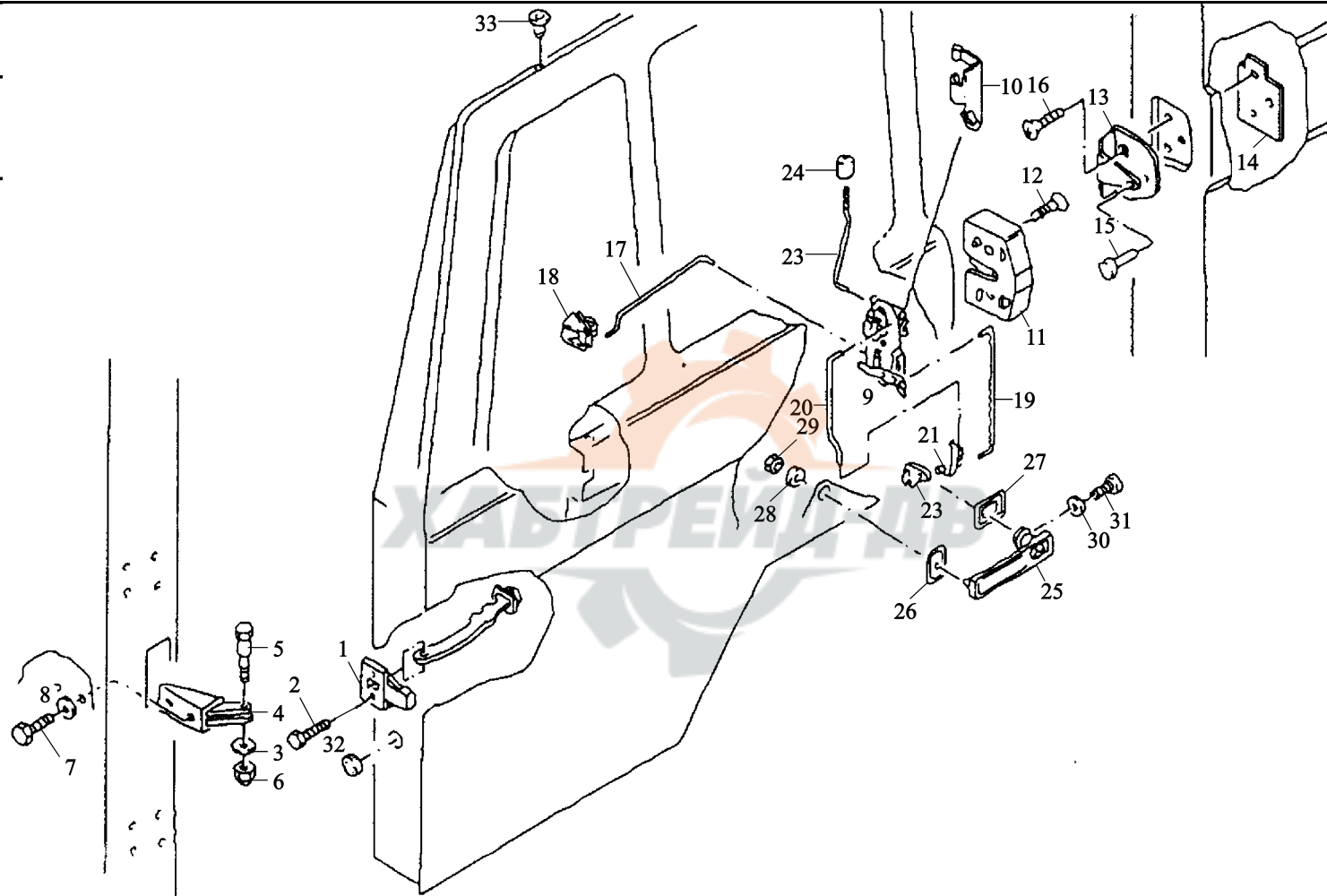

DM LEFT

E  
rk

23	81.62680.0087	左操纵杆	Operating rod assembly left	1		
	81.62680.5013	左操纵杆	Operating rod assembly left	1		
24	81.62680.0059	按 钮	Knob	1		
25	81.97100.6098	外手柄总成	Lock set in cab	1		
26	81.62642.0032	橡胶垫板	Escutcheon	1		
27	81.62642.0031	橡胶垫板	Escutcheon	1		
28	06.15191.0207	垫 片	Washer	1		
29	06.11184.0112	六角螺母	Hexagon nut	1		
30	06.16739.0011	弹簧垫圈	Washer	1		6.4×18×1.6-140HV-MAN183-B1 M6-8-MAN183-B1
31	06.02829.0010	盘头螺钉	Pan-head screw	2		A6.4×12×1.6-200HV-
32	81.96001.0388	穿线护套	Grommet	2		MAN183-B1
33	81.96002.0142	塞 子	Plug	1		M6×10-MK5-4.8-H-A2C
				2		

右车门止动器和车门操作系统

DOOR ARRESTOR AND DOOR ACUATING SYSTEM RIGHT

右车门

序号
NO

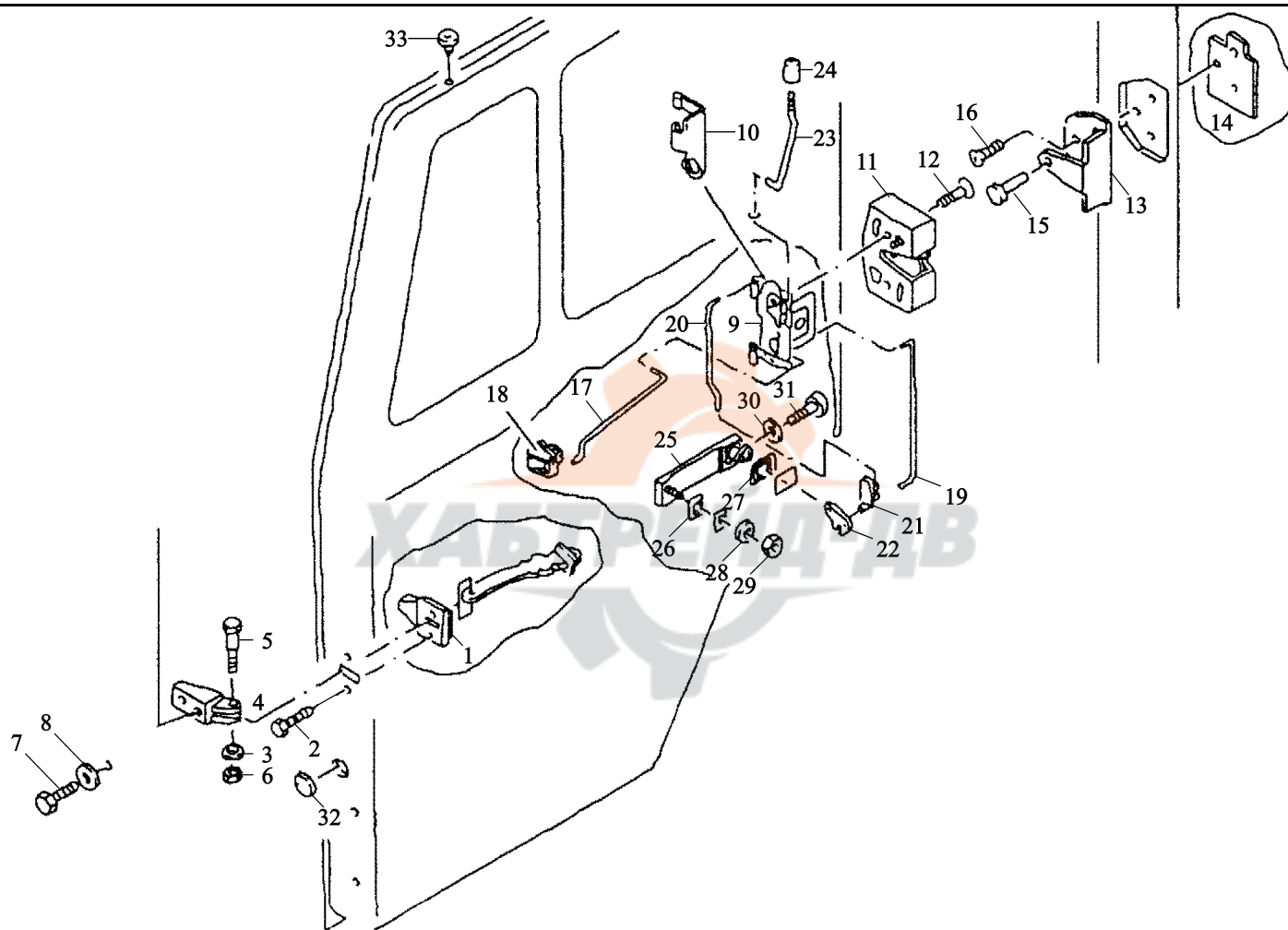

RIGHT

k



1	81.62670.6011	车门止动器总成	Door arrestor assembly	1	
2	06.01470.0409	带垫六角螺栓	Hex bolt	2	M6×12SK-8.8-MAN183-A2C
3	06.15013.6109	平垫圈	Washer	2	A6.4×12×1.6×200HV- MAN183-B1
4	81.62692.5001	支座总成	Support assembly	1	
5	81.62691.0010	螺 钉	Screw	1	
6	06.12072.0153	锁紧螺母	Hex cap lock nut	1	
7	06.01303.3113	锁紧螺栓	Hex bolt	2	M6-6-A2C
8	06.15013.6111	垫 片	Washer	2	A8.4×16×1.6-200HV- MAN183-B1
9	DZ1643340040	右车门锁总成	Door lock assembly	1	
10	81.62680.0058	红夹子	Door lock assembly	4	
11	81.62680.6096	右锁块	Lock assembly	1	
12	06.02829.0009	锁紧螺钉	Raised counters head locking screw	2	M8×30-MK8-A2
13	81.62680.0055	碰板	Striker plate	1	
14	81.90750.0571	螺纹板	Threded plate	1	
15	81.62680.0070	销 子	Pin	1	
16	06.04308.0909	沉头螺钉	Oval-head counter sunk screw	2	M8×16-A2
17	81.62680.0084	右操纵杆	Operating rod right	1	
18	81.62680.0083	导 板	Guide plate	1	
19	81.62680.0074	操纵杆（四）	Operating rod	1	
20	81.62680.0072	操纵杆（三）	Operating rod	1	
21	81.62680.0058	红夹子	Clip red	1	
22	81.62641.0086	支架总成	Lever assembly right	1	

右车门止动器和车门操作系统

DOOR ARRESTOR AND DOOR ACUATING SYSTEM RIGHT

右车门

序号
NO

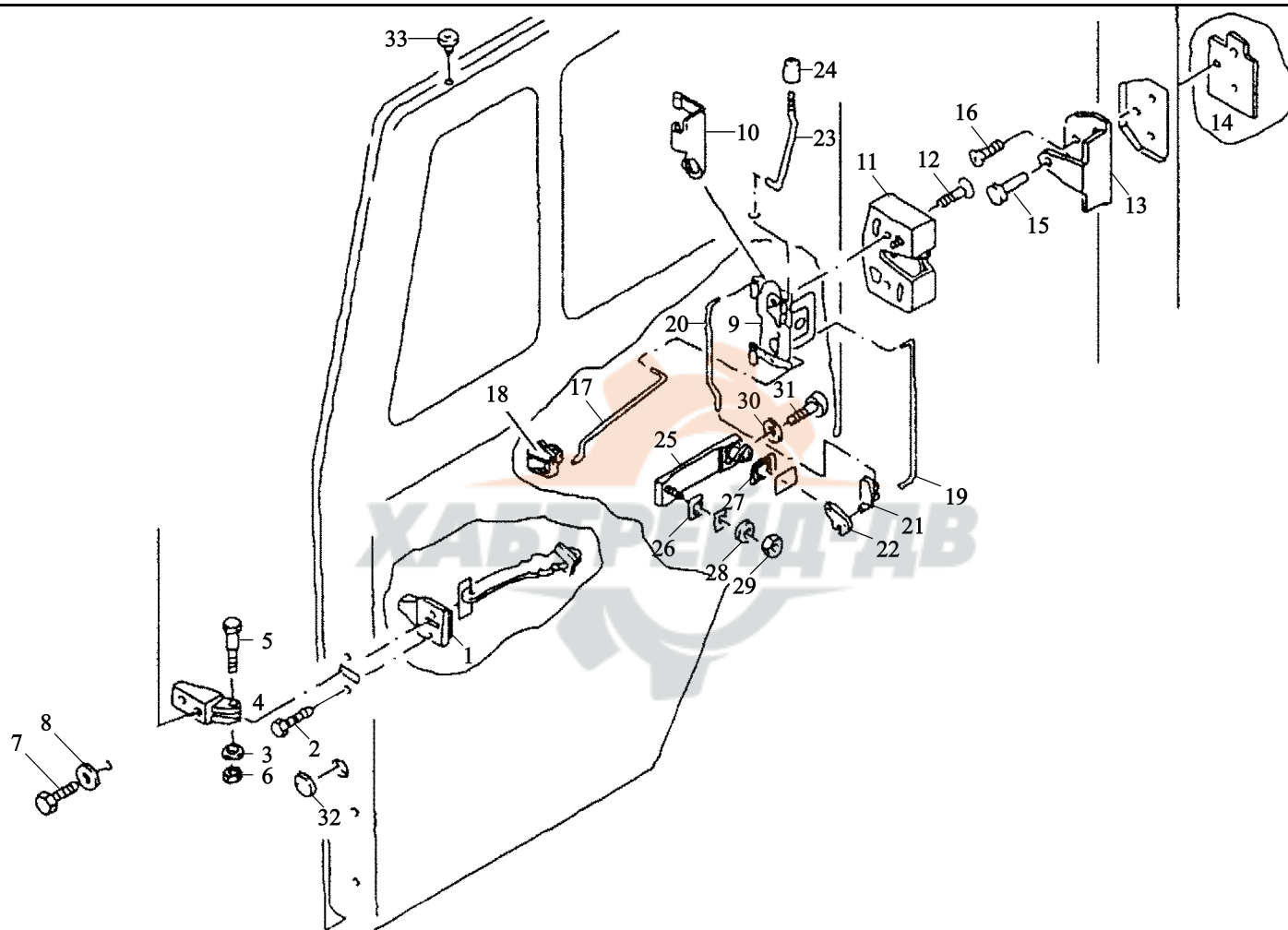

RIGHT

k

23	81.62680.0086	右操纵杆	Operating rod assembly right	1		
	81.62680.5014	右操纵杆	Operating rod assembly right	1		
24	81.62680.0049	按 钮	Knob	2		
25	81.97100.6098	外手柄总成	Lock set in cab	1		(含左右外手柄、点火开关、 油箱、 锁芯)
26	81.62642.0032	橡胶垫板	Escutcheon	1		
27	81.62642.0031	橡胶垫板	Escutcheon	1		
28	06.15191.0207	垫 片	Washer	1		
29	06.11184.0112	六角螺母	Hexagon nut	2		6.4×18×1.6-140HV-MAN183-B1
30	06.16739.0011	弹簧垫圈	Washer	1		M6-8-MAN183-B1 A6.4×12×1.6-200HV- MAN183-B1
31	06.02829.0010	盘头螺钉	Pan-head screw	2		M6×10-MK5-4.8-N-A2C
32	81.96001.0388	穿线护套	Pan-head screw	1		
33	81.96002.0142	塞 子	Plug	2		8.3×11-13-PE

# 左车门铰链和右车门铰链 DOOR HINGE LEFT AND RIGHT

## 左车门铰

序号	
NO	

注  
emark

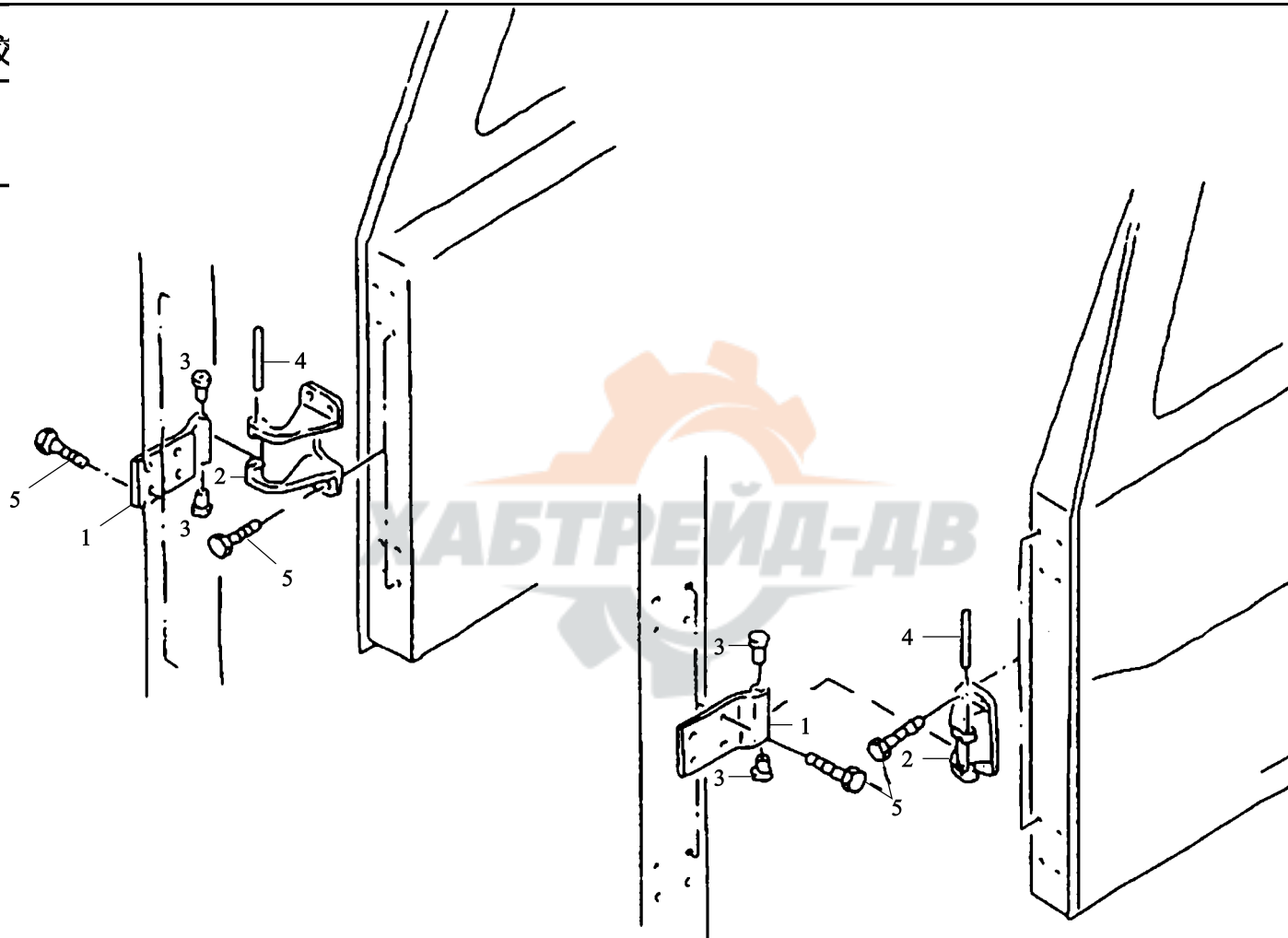

1	81.62690.0047	铰链零件 II	Hinge part	4		
2	81.62690.0042	铰链零件 I	Hinge part	4		
3	81.62690.0046	衬套	Bush	8		
4	81.62691.0007	铰链轴	Hinge pin	4		
5	06.01470.0513	六角螺栓	Hex bolt	32		M8×25Z1-8.8-MAN183-A2C
	81.62690.6026	车门铰链总成	Door hinge assy	4		



# 手动玻璃升降器 HANDLE WINDOW LIFTER

手动玻璃升降器 HAI

序号 NO	件号 Part.No	名 Desi
----------	---------------	-----------

车型 ed type	备注 Remark
---------------	--------------

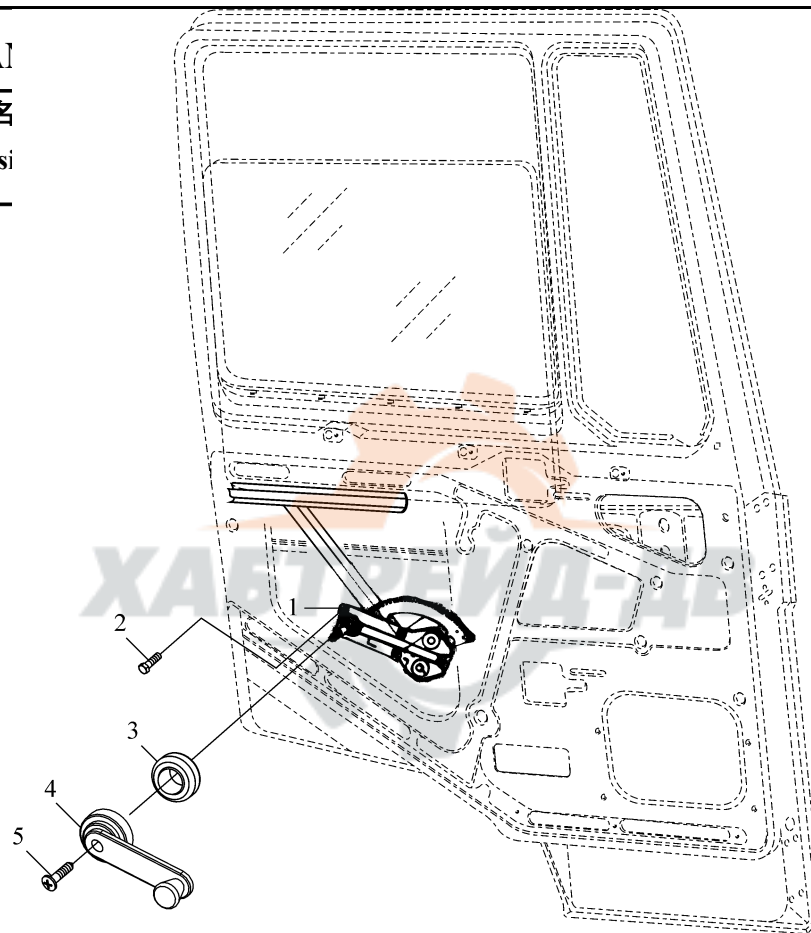

1	81.62640.6057	左玻璃升降器	Window lifter assembly left	1		
	81.62640.6058	右玻璃升降器	Window lifter assembly	1		
2	06.04209.0033	盘头螺钉	right	4		M6×10Z1-4.8-H-A2C
	06.02829.0010	盘头螺钉	Pan-head screw	5		M6×10-MK5-4.8-H-A2C
3	81.62640.0095	手柄护罩	Pan-head screw	1		
4	81.62641.6052	升降器手柄	Escutcheon	1		
5	06.04300.4706	十字槽沉头螺钉	Window crank assembly	1		M5×10-4.8-H2I
			Oval-head countersunk screw			



电动控制的左车门窗升降器 DOOR WINDOW LIFTER LEFT ELECTRICALLY OPERATED

电动控制的左

LY OPERATED

序号 NO	件号 Part.No
----------	---------------

备注 Remark
--------------

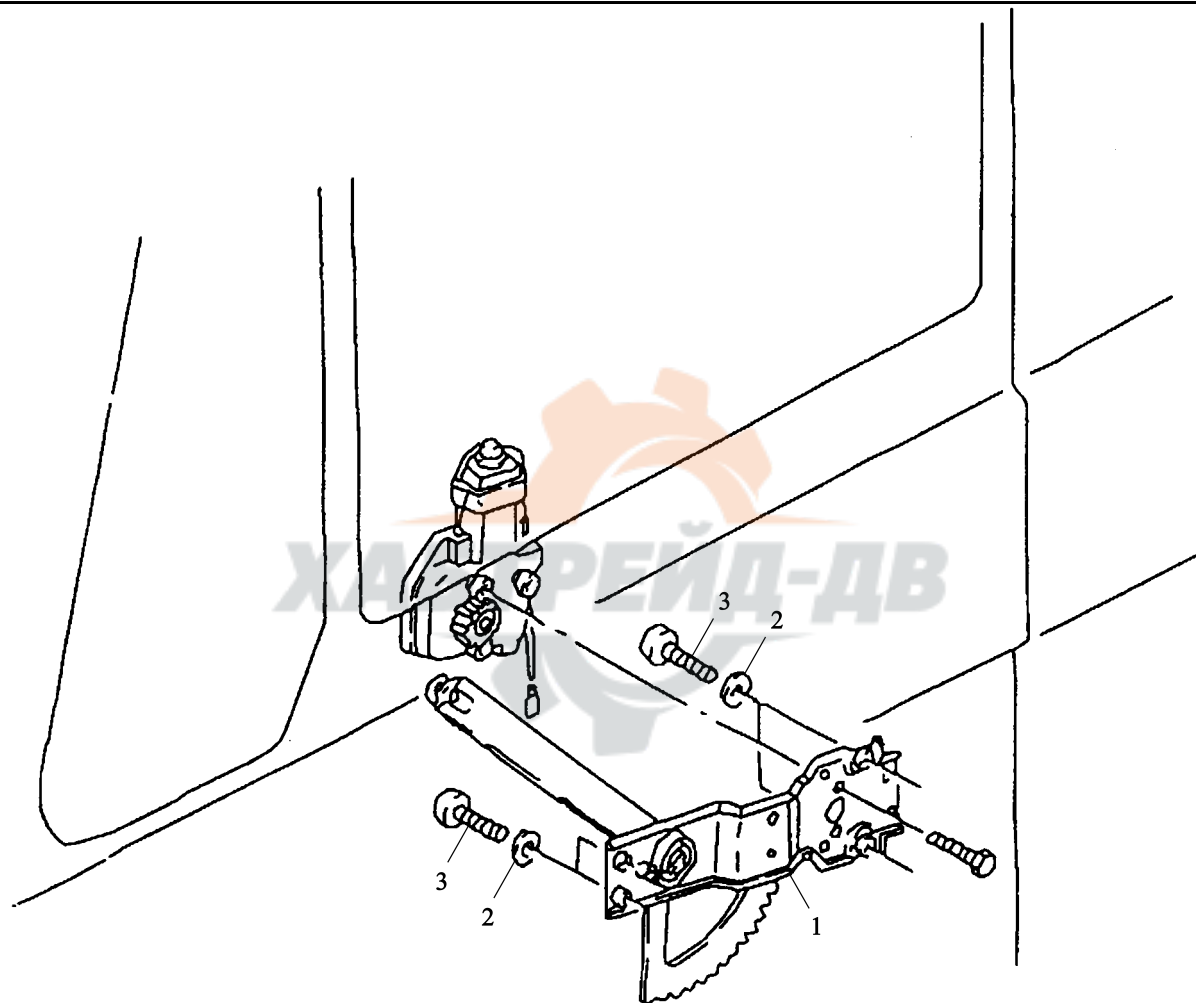



1	81.62640.6057	左玻璃升降器	Left window lifter	1		
	81.62640.6049	左电动玻璃升降器	Left electrical window lifter	1		
2	06.15013.6109	平垫圈	Flat washer	4		A6.4×12×1.6-200HV-A3C
3	06.02829.0010	盘头螺钉	Pan-head screw	4		



电动控制的右车门窗升降器

DOOR WINDOW LIFTER RIGHT ELECTRICALLY OPERATED

电动控制的右

序号	件号
NO	Part.No

ALLY OPERATED

备注  
Remark

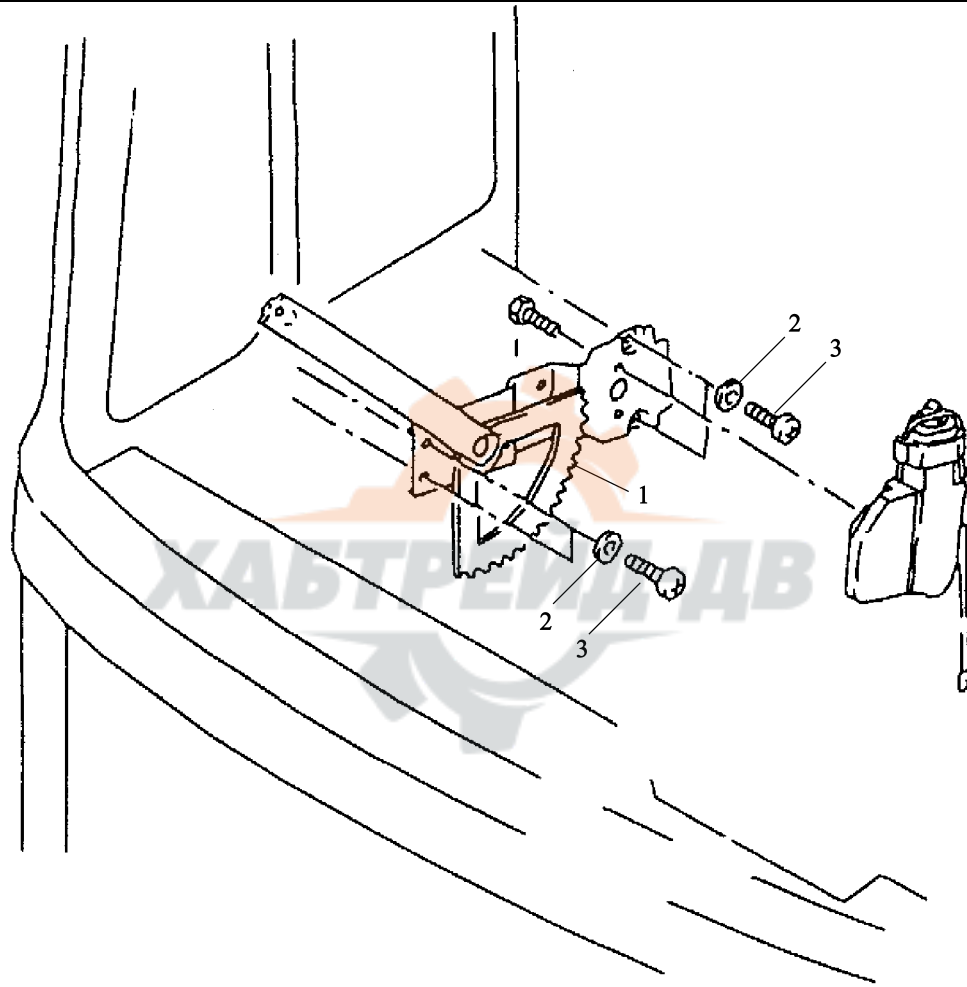

1	81.62640.6058	右玻璃升降器	Right window lifter	1		
	81.62640.6050	右电动玻璃升降器	Right electrical window lifter	1		
2	06.15013.6109	平垫圈	Flat washer	4		
3	06.02829.0010	盘头螺钉	Pan-head screw	4		



左车门部件 DOOR COVERING LEFT

左  
序

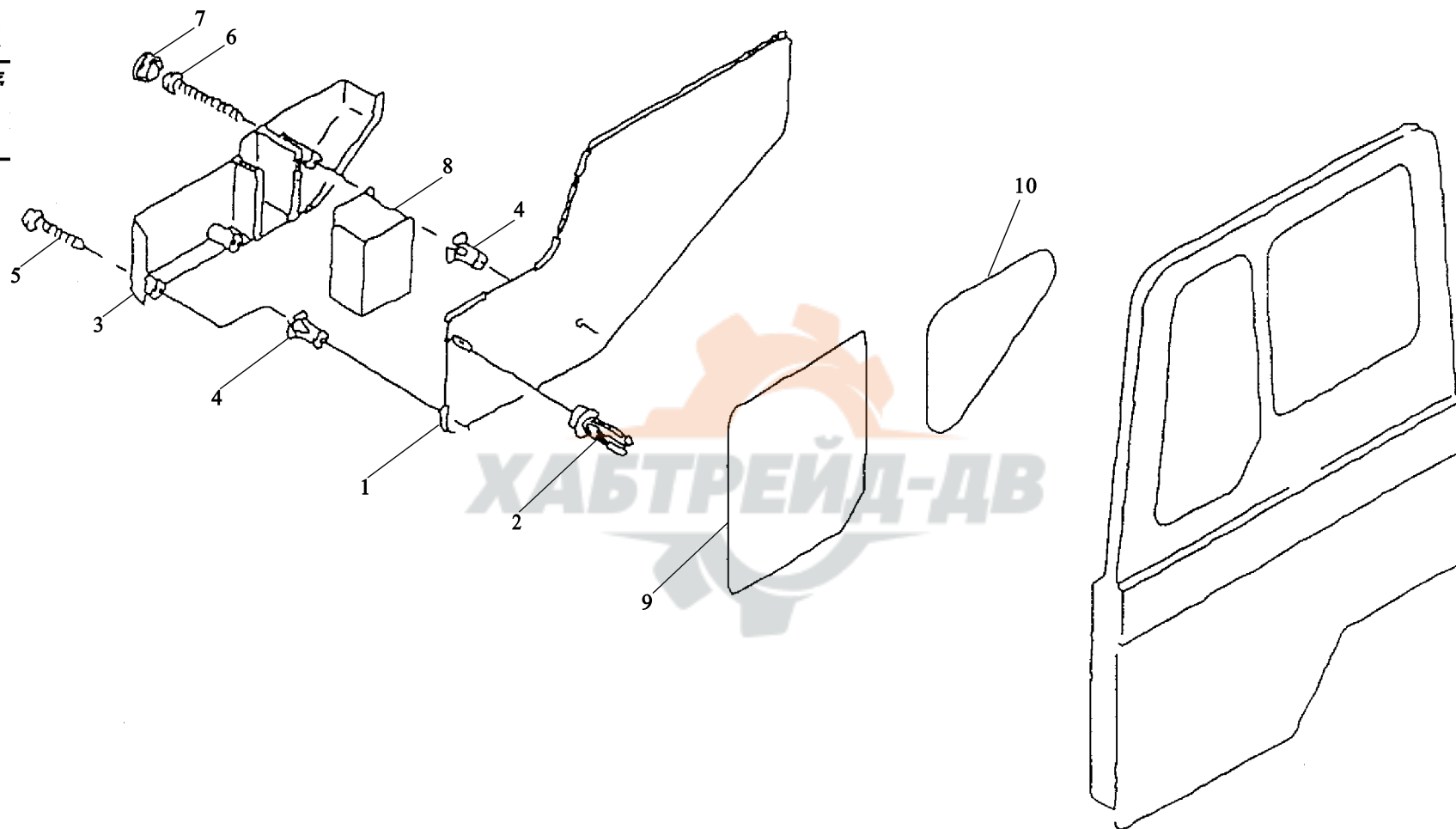

1	81.62630.5095	左车门衬里总成	Door lining assembly left	1		
2	81.62640.0092	卡 箍	Clamp	5		
3	81.63745.0017	左杂物箱	Tool box left	1		
4	81.90685.0374	塑料方螺母	Speed nut	6		
5	06.07159.0008	盘头螺钉	Grooved oval head collar bolt	5		4.8×25
6	06.07159.0010	自攻螺钉	Grooved oval head collar bolt	1		4.8×60
7	81.96002.0414	堵 塞	Plug	1		
8	81.63745.0015	杯 座	Bottle holder	1		
9	81.62630.2263	左护板	Foil left	1		
10	81.62630.2259	左装饰片	Foil left	1		



右车门部件 DOOR COVERING RIGHT

右车门部件 DOOR

序号 NO	件号 Part.No	

型 号	备注 Remark

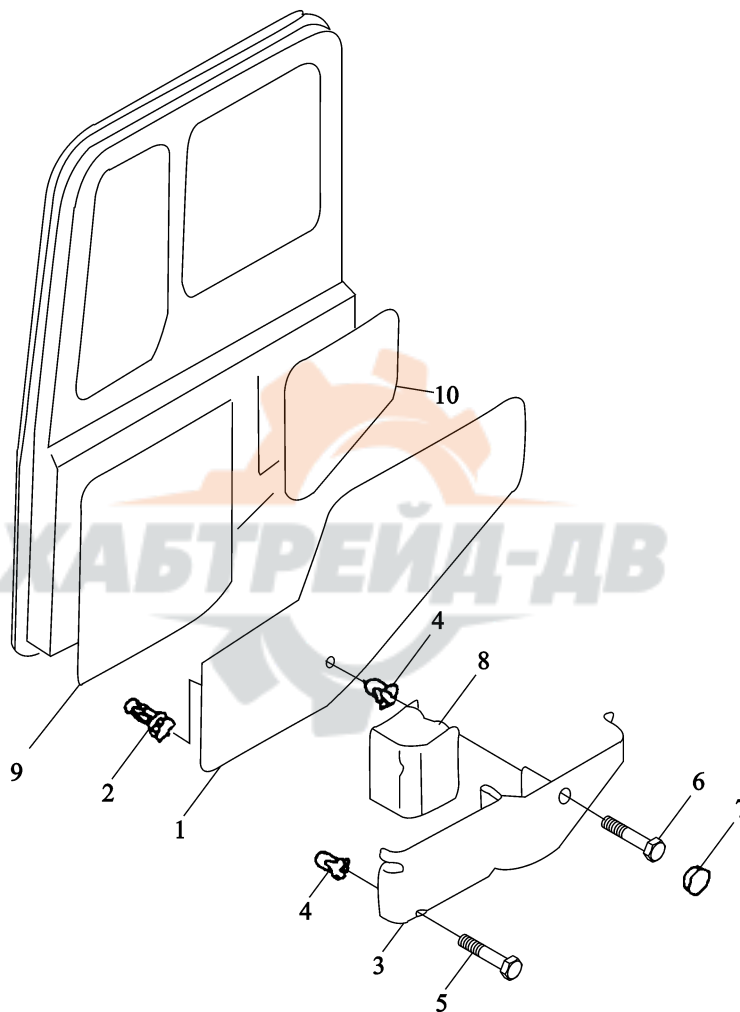

1	81.62630.5096	右车门衬里总成	Door lining assembly right	1		
2	81.62640.0092	卡 箍	Clamp	5		
3	81.63745.0016	右杂物箱	Tool box right	1		
4	81.90685.0374	塑料方螺母	Speed nut	6		
5	06.07159.0008	盘头螺钉	Groovde oval head collar bolt	5		
6	06.07159.0010	自攻螺钉	Groovde oval head collar bolt	1		
7	81.96002.0414	塞 子	Plug	1		
8	81.63745.0015	杯 座	Bottle holder	1		
9	81.62630.2262	右护板	Foil right	1		
10	81.62630.2258	右装饰片	Foil right	1		



不带车窗手柄的左车窗 DOOR WINDOW LEFT WITHOUT WINDOW CRANK

不带车窗

序号	
NO	

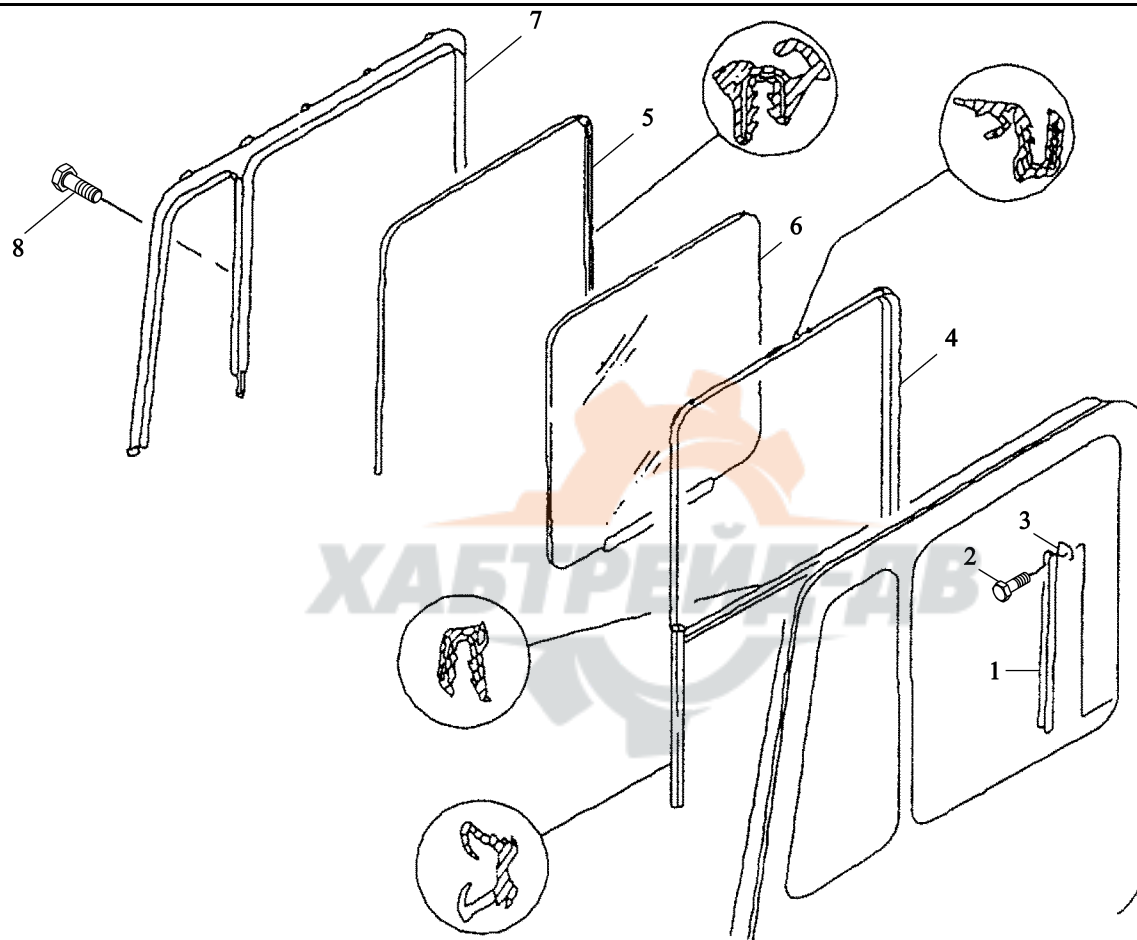

注  
emark



1	81.62640.0081	导 轨	Guide rail for window rear	1		
2	06.07164.1604	沉头自攻螺钉	Self-tapping countersunk screw	2		ST4.8×16C-H-A3C
3	06.13189.0025	簧片螺母	Speed nut	2		ST4.8-1-A3C
4	81.62651.0050	密封条	Seal strip	1		
5	81.62651.0045	密封条	Seal strip	1		
6	81.62645.6011	车门玻璃总成	Door glass assembly	1		
7	81.62630.0047	左窗框	Window frame right	1		
8	06.07159.0008	盘头螺钉	Groovde oval head collar bolt	4		ST4.8×25C-H-A3R



不带车窗手柄的右车窗 DOOR WINDOW RIGHT WITHOUT WINDOW CRANK

不带车窗

序号	
NO	

注
emark

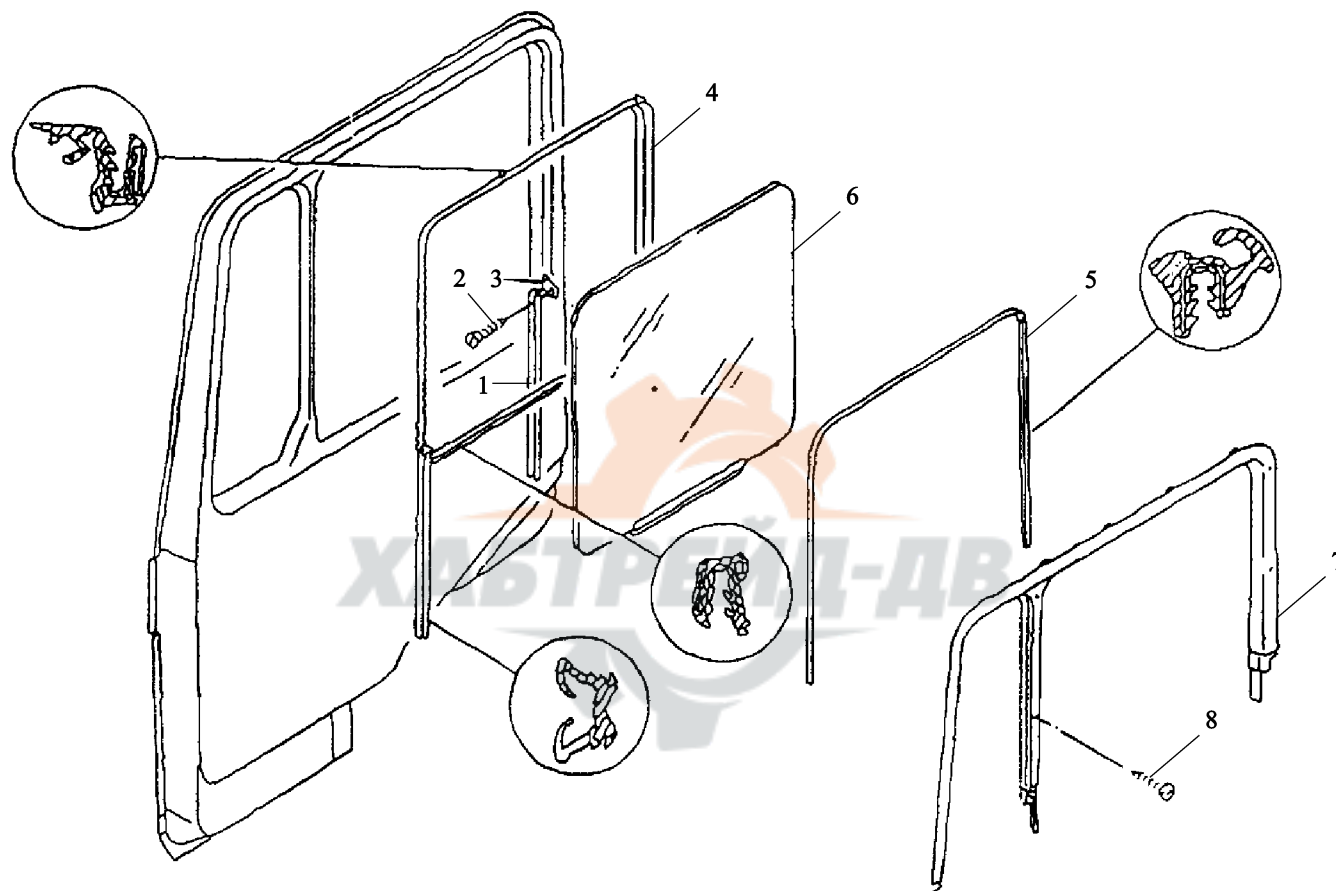

1	81.62640.0081	导 轨	Guide rail for window rear	1		
2	06.07164.1604	沉头自攻螺钉	Self-tapping countersunk screw	2		ST4.8×16C-H-A3C
3	06.13189.0025	簧片螺母	Speed nut	2		SR4.8-1-A3C
4	81.62651.0050	密封条	Seal strip	1		
5	81.62651.0045	密封条	Seal strip	1		
6	81.62645.6011	车门玻璃总成	Door glass assembly	1		
7	81.62630.0048	右窗框	Window frame right	1		
8	06.07159.0008	盘头螺钉	Groovde oval head collar bolt	4		ST4.8×25C-H-A3R



# 左车门镶板 DOOR PANELING LEFT

## 左车门镶

序号 NO	件 P:
----------	---------

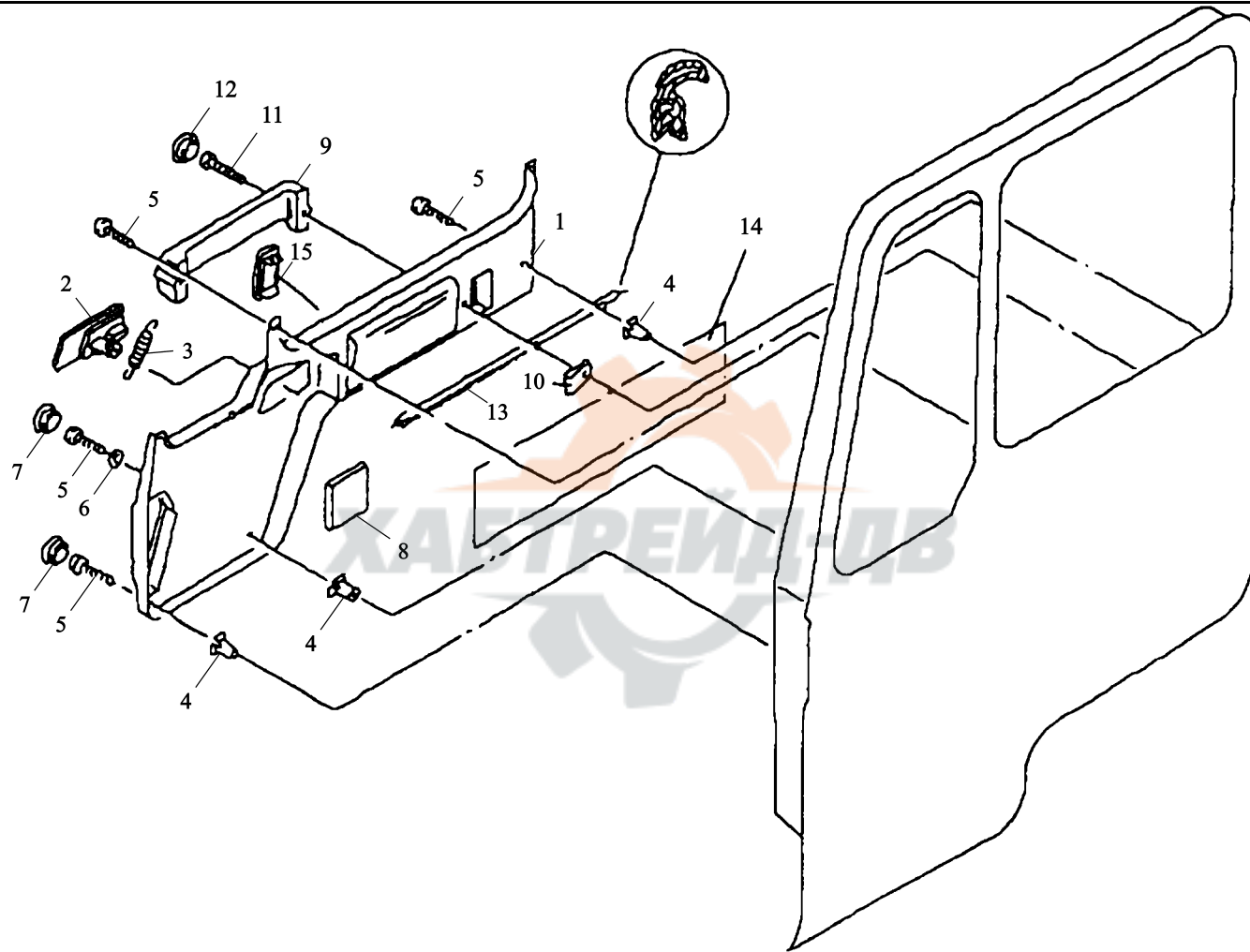

备注  
Remark

1	81.62630.6021	左车门镶板总成	Door paneling assembly left	1	
2	81.62641.0099	左车门把手	Door handle left	1	
3	81.97610.0288	拉 簧	Tension spring	1	
4	81.90685.0374	塑料方螺母	Speed nut	4	B4.8-9.7/9.7×18.0-PA-NF
5	06.07159.0008	盘头螺栓	Grooved oval head collar bolt	6	ST4.8×25C-H-A3R
6	06.15190.0306	垫 圈	Washer	3	5.3×15×1.2-140HV-MAN183-B1
7	81.96002.0414	塞 子	Plug	3	
8	81.98702.0006	衬 垫	Gasket	1	
9	81.62641.0101	门内拉手	Pull handle	1	
10	06.13189.0056	簧片螺母	Slip-on nut	2	M6-16×24×4.0-C45-ZN
11	06.04201.2607	十字槽盘头螺钉	Pan-head screw	4	M6×16-4.8-H-H31
12	81.96002.0414	螺 塞	Plug	2	
13	81.62651.0049	密封件	Seal	1	
14	81.62630.2276	装饰件	Foil	1	
	81.62630.2259	左装饰件	Foil left	1	
15	81.61446.0037	翘板开关盖板	Cover	2	

# 右车门镶板 DOOR PANELLING RIGHT

## 右车门镶板

序号 NO	件号 Part.No
----------	---------------

备注 Remark
--------------

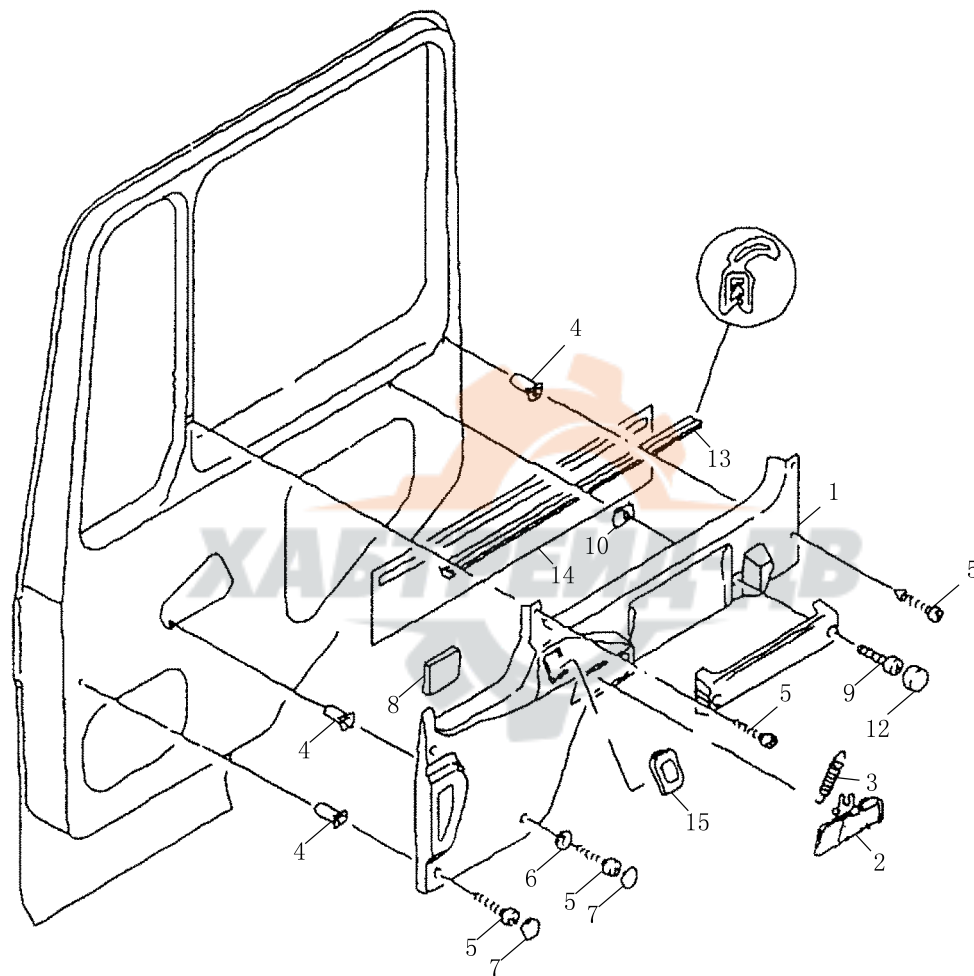

1	81.62630.6020	右车门镶板总成	Door panelling assembly right	1	
2	81.62641.0100	右车门把手	Door handle right	1	
3	81.97610.0288	拉 簧	Tension soring	1	
4	81.90685.0374	塑料方螺母	Speed nut	4	B4.8-9.7/9.7×18.0-PA-NF
5	06.07159.0008	盘头螺钉	Grooved oval headcollar	6	ST4.8×25C-H-A3R
6	06.15190.0306	垫 圈	bolt	3	5.3×15×1.2-140HV-MAN183-B1
7	81.96002.0414	塞 子	Washer	3	
8	81.98702.0006	衬 垫	Plug	1	
9	81.62641.0101	门内拉手	Gasket	1	
10	06.13189.0056	簧片螺母	Pull handle	2	M6-16×24×4.0-C45-ZN
11	06.04201.2607	十字槽盘头螺钉	Slip-on nut	4	M6×16-4.8-H-H31
12	81.96002.0414	塞 子	Pan-head screw	2	
13	81.62651.0049	密封条	Plug	1	
14	81.62630.2276	装饰件	Seal	1	
	81.62630.2258	右挡片	Foil	1	
15	81.61446.0037	翘板开关盖板 -	Foil right Cover	2	不装电动玻璃升降器时数量为 4

左非旋转式车窗

DOOR WINDOW DOOR LEFT NON-SWIVELLING

左非旋转式车窗

序号 NO	件号 Part.No

备注 Remark

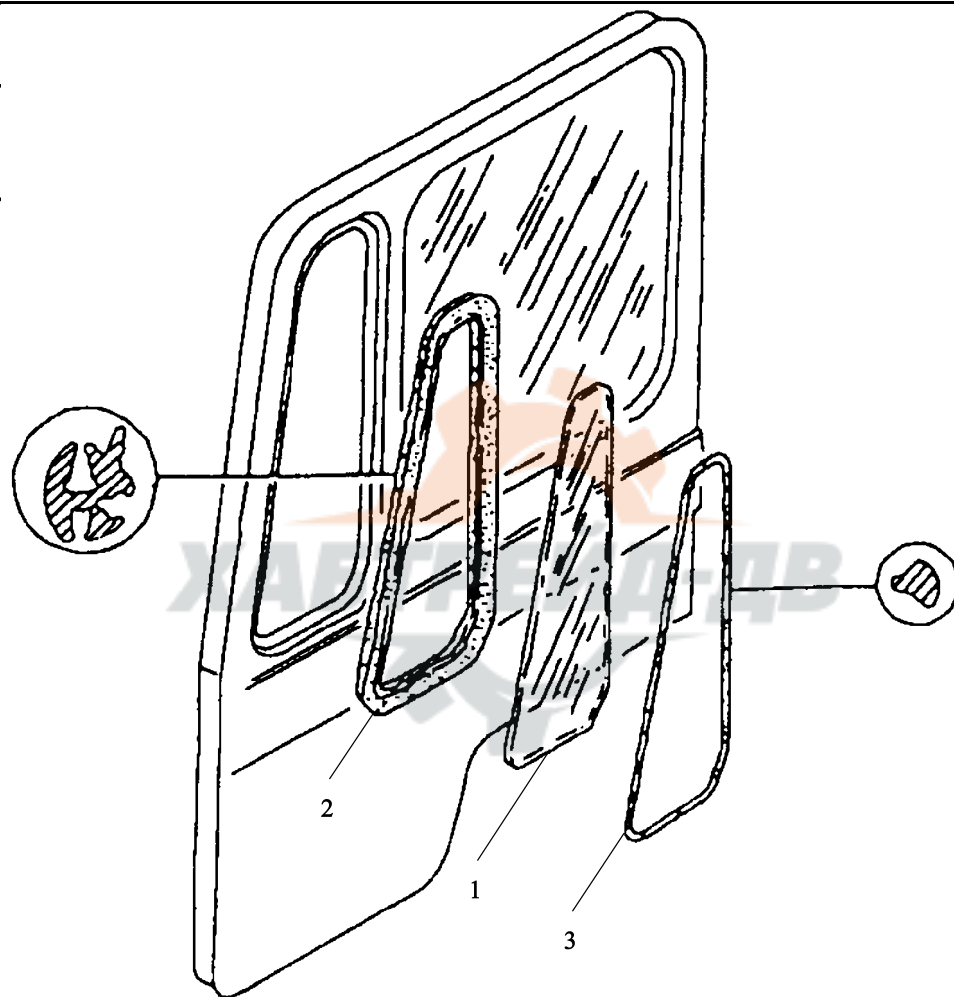



1	81.62650.0037	角窗玻璃	Door glass	1		
2	81.96120.0885	密封框	Sealing frame	1		
3	A0.00182.8078	黑色嵌条	Filler strip black			



右非旋转式车窗

DOOR WINDOW DOOR RIGHT NON-SWIVELLING

右非旋转式车窗

序号 NO	件号 Part.No

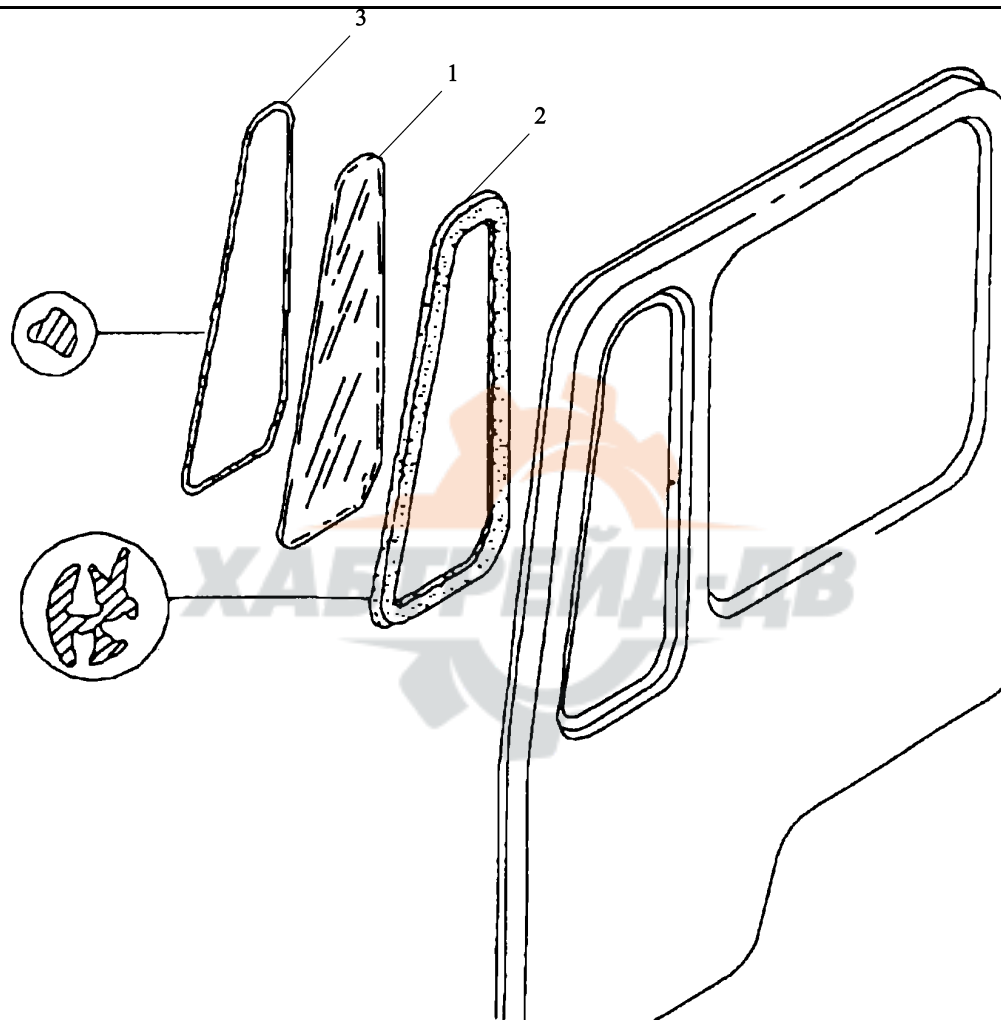

备注  
Remark

1	81.62650.0037	角窗玻璃	Door glass	1		
2	81.96120.0885	密封框	Sealing frame	1		
3	A0.00182.8078	黑色嵌条	Filler strip black			



不带横向加强件的地板支架

FLOOR SUPPORT WITHOUT CROSS REINFORCEMENT

不带横向加强件

序号 NO	件号 Part.No
----------	---------------

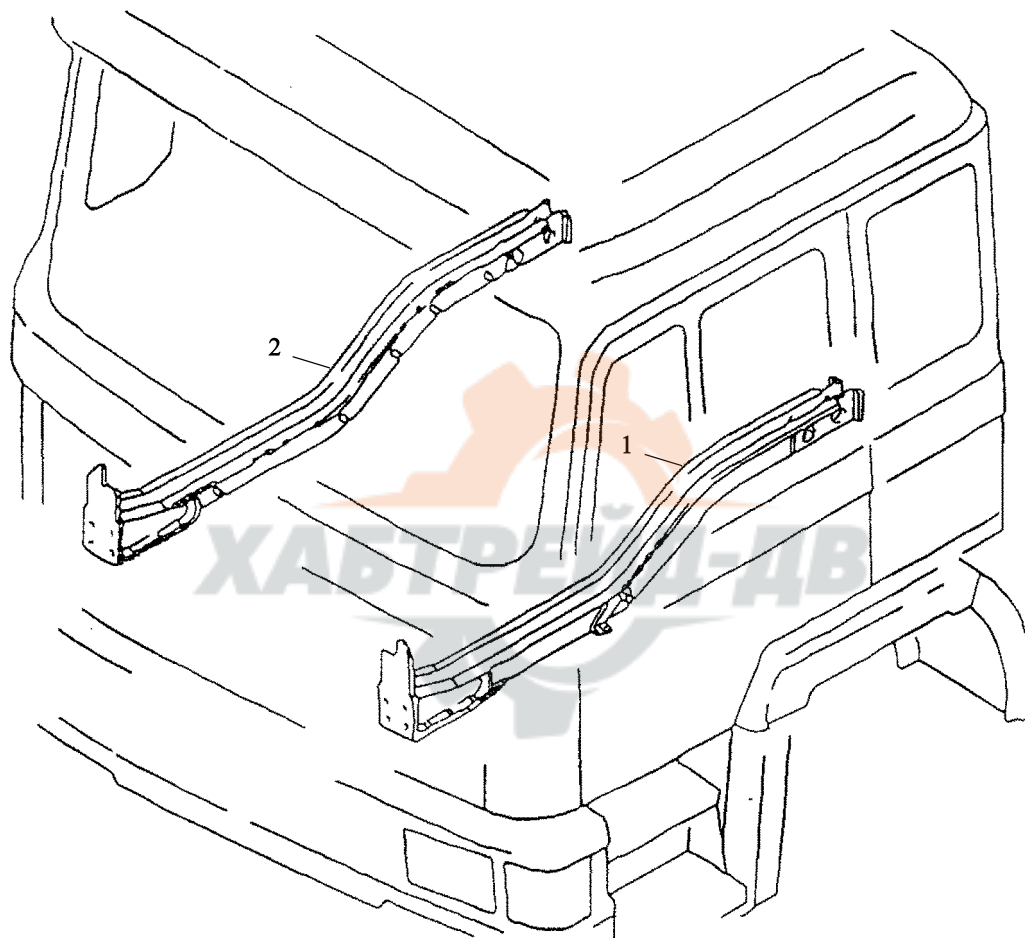

REINFORCEMENT

备注  
Remark

1	81.62811.4541	左纵梁总成	side member assembly	1		
2	8162811.4550	右纵梁总成	side member assembly	1		



地板横向加强件

CROSS REINFORCEMENT FLOOR SUPPORT

地板横

序号
NO

注
mark

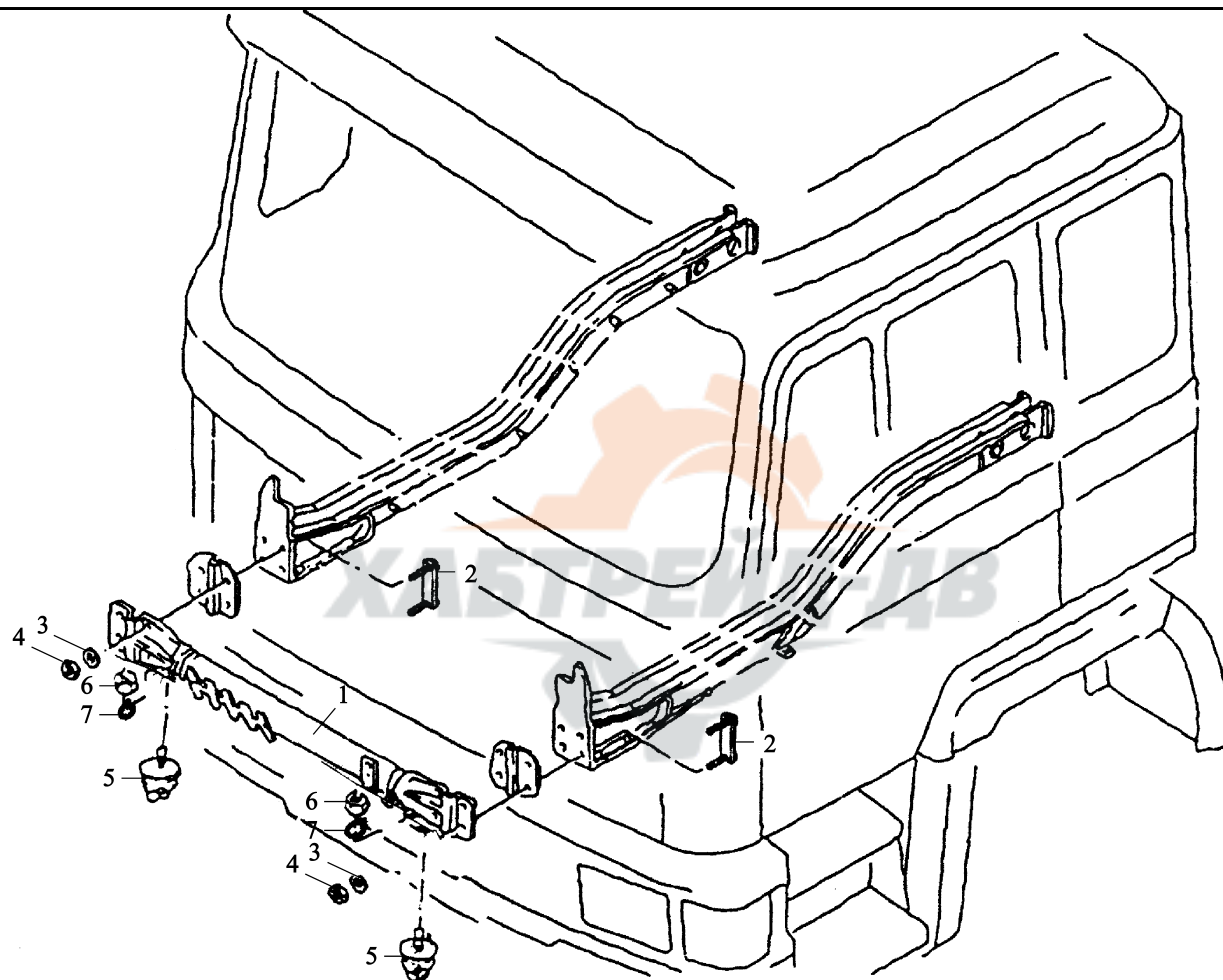

1	81.62821.5049	横梁总成	Cross reinforcement assembly	1		
2	81.97487.5027	连接板	Fish plate assembly	4		
3	06.15013.0412	垫 片	Washer	8		5×20×2
4	06.11064.2115	螺 母	Hexagon nut	8		M10-8-MAN183-B1
5	81.96210.0536	缓冲块	Cushion	2		
6	06.11240.0206	六角螺母	Hex nut	2		BM10-8-A3C
7	81.90714.0349	垫 片	Washer	2		11×50×15



# 左座驾驶车辆驾驶室翻转机构

# CAB TILTING MECHANISM L.H. DRIVE VEHICLE

左座驾

序号
NO

注
ark

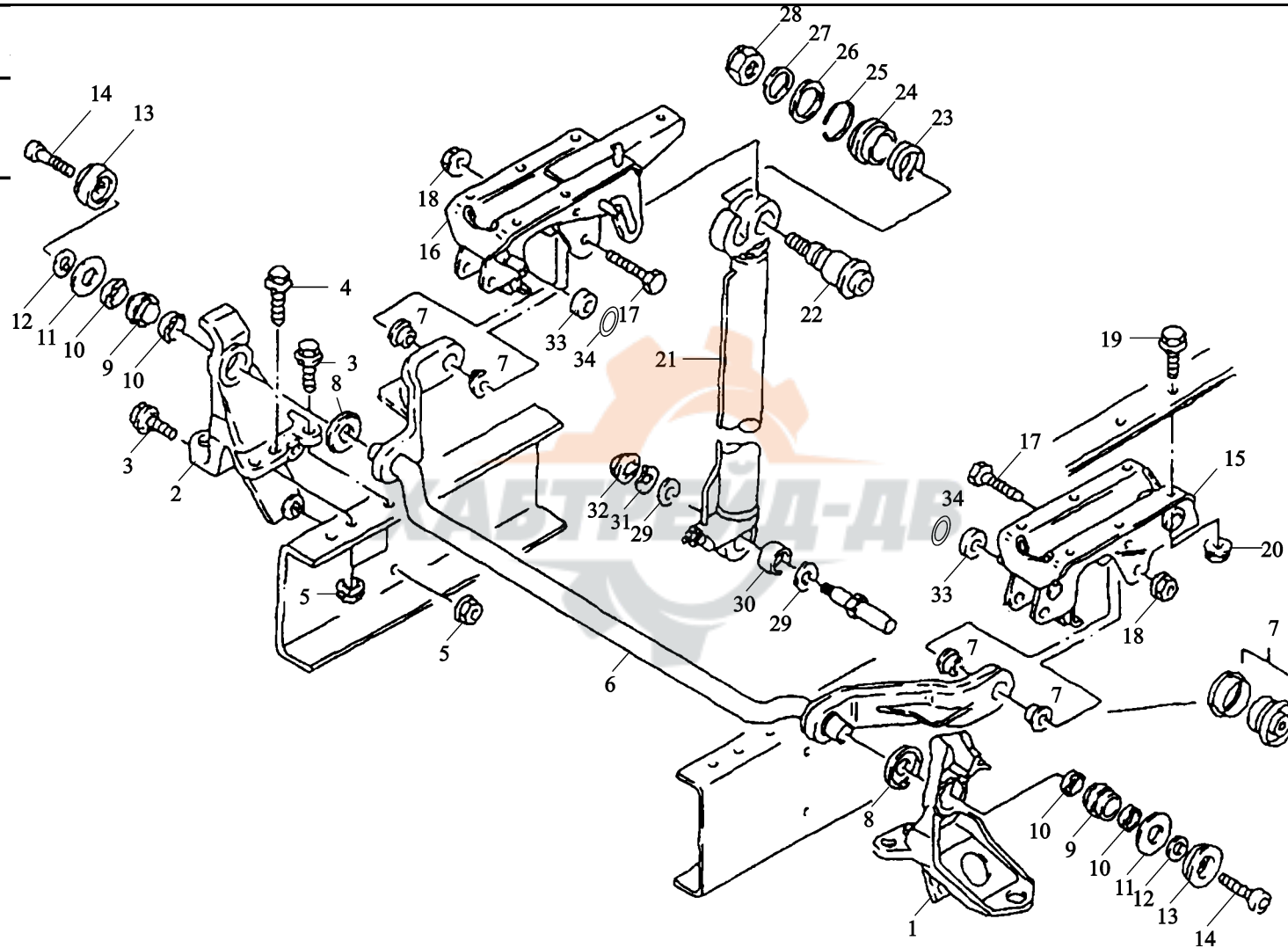



1	81.41720.6061	前悬置左支座	Bracket left	1		
2	81.41720.6060	前悬置右支座	Bracket right	1		
3	06.02813.4913	六角锁紧螺钉	Hex lock screw	6		M14×40
4	06.02813.4915	六角锁紧螺钉	Hex lock screw	4		M14×55
5	06.11251.2005	锁紧螺母	Hex lock nut	10		M14×1.5-10-MAN183-B1
6	81.41715.6010	翻转轴	Locating arm assembly	1		
7	81.96210.0437	垫圈	Rubber pad plastic/steel	2		
8	81.90713.0909	垫片	Shim	2		33×65×6-ST/GI
9	06.36950.0510	轴承衬套	Bearing bush	2		
10	81.96503.0129	垫片	Seal	4		35.5×47×5-PUR
11	81.96101.0638	垫片	Washer	2		32×70×4-PAF
12	06.15013.0415	垫片	Washer	2		A15×28×2.5-200HV- MAN183-B1
13	81.96210.0407	橡胶垫	Rubber pad	2		
14	06.02099.0211	内六角圆柱头螺钉	Cylinder crew	2		M14×30
15	81.41720.5341	翻转轴左支撑总成	Bracket assembly left	1		
16	81.41720.5340	翻转轴右支撑总成	Bracket assembly right	1		
17	06.01499.0150	六角头螺栓	Hex shoulder stud	2		M16×100
18	06.11241.0117	六角锁紧螺母	Hex lock nut	2		AM16×1.5-10-A3C
19	06.01739.0054	螺栓	Hex bolt	11		M12×1.5×35-8.8-A- MAN183-A3C
20	06.11222.6507	六角螺栓	Hex collar lock nut	14		M12×1.5-MAN183-B1
21	81.41723.6099	翻转油缸	Hydraulic cylinder	1		
	DZ1643820030	翻转油缸	Hydraulic cylinder	1		
	DZ1643820031	翻转油缸	Hydraulic cylinder			加长41

# 左座驾驶车辆驾驶室翻转机构

# CAB TILTING MECHANISM L.H. DRIVE VEHICLE

左座驾

序号
NO

注  
ark

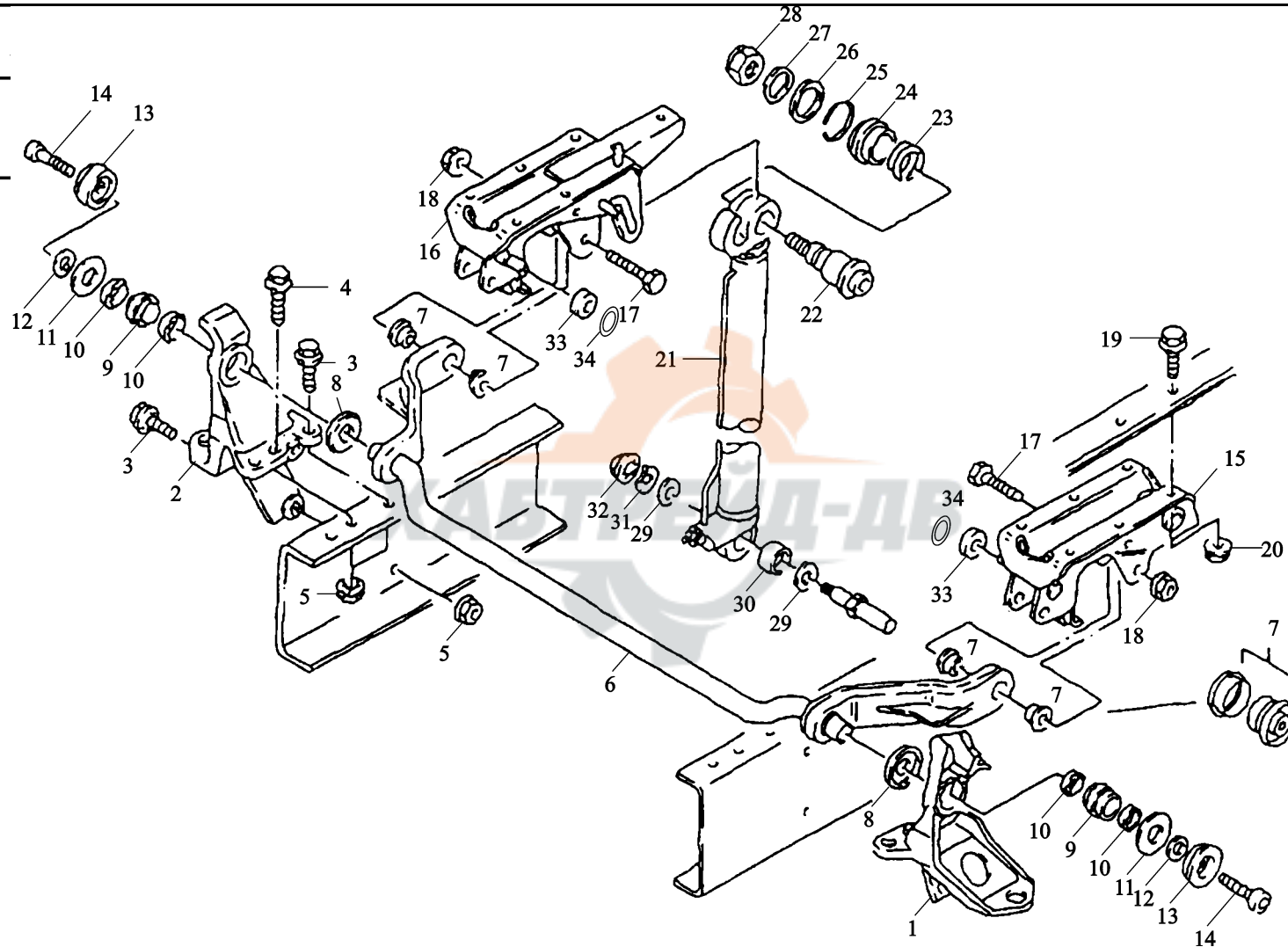

	DZ16.4382.0050	翻转油缸	Hydraulic cylinder	1		加长 100
	DZ16.4082.002	翻转油缸	Hydraulic cylinder	1		右置车 to right
22	1	销 子	Pin	1		
23	81.91020.0734	压力弹簧	Pressure spring	1		
24	81.97602.0764	垫 片	Washer	1		1.6×32.4×25-X12CRNI177K
25	81.41723.0064	垫 片	Circlip	1		
26	81.90820.0500	垫 圈	Washer	1		A23.2×1.25
27	81.90713.0697	衬 板	Washer	1		25×38×3-PE
28	81.90713.0696	螺 母	Hex lock nut	1		16.2×36×4-ST2K32-A4C
29	06.11241.0117	垫 片	Washer	2		AM16×1.5-10-A3C
30	81.90712.0983	石棉垫圈	Seal	2		
31	81.96502.0867	垫 片	Washer	1		29.5×40×7-PUR
32	81.90713.0695	锁紧螺母	Hex lock nut	1		18.2×44×3-ST50-2-A3C
33	06.11241.0321	滚 柱	Bush	2		AM18×2-10-MAN183-B1
34	81.95801.0114	挡 圈	Circlip	2		20×40×20
	06.29010.0117					20×1.20-ZNPHR5F

# 前 支 承 弹 簧      FRONT BEARING SPRING

## 前 支 承 弹

序 号	作
NO	P

备 注
Remark

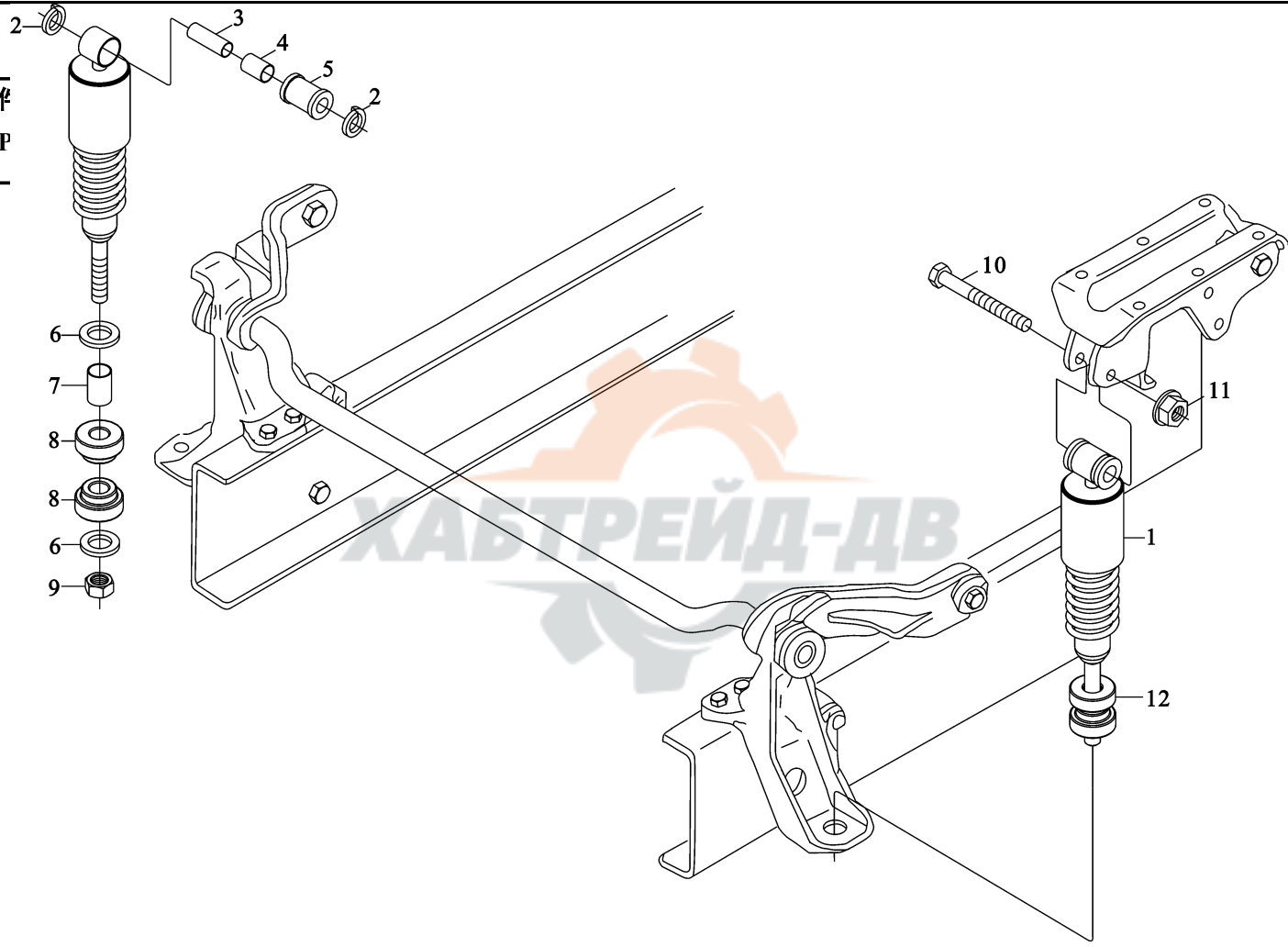

1	81.41722.6012	弹簧支撑	Spring strut	2	
2	81.91730.0116	垫片	Sleeve	2	
3	81.93021.0102	支承套	Bearing bush	1	14.2×20×45
4	81.93021.0103	衬套	Bush	2	20×23×20
5	81.43706.0039	胶套	Rubber bush	1	16×35.5×26
6	81.43703.0008	垫圈	Washer	2	
7	81.93021.0104	支承套	Bearing bush	1	
8	81.43706.0033	胶套	Rubber bush	2	
9	06.11241.0307	自锁螺母	Hex lock nut	1	AM10×1-10-MAN183-B1
10	06.01734.4420	螺栓	Hex bolt	2	M14×1.5×75-10.9-MAN183-PHR
11	06.11241.0314	螺母	Hex lock nut	2	AM14.5×1.5-10-MAN183-B1
12	06.15190.0310	垫圈	Washer	NB	10.5×30×2.5-140HV-MAN183-B1
	81.90712.0032	垫圈	Washer	NB	17×70×5-QSTE380N-A4C

# 长途运输驾驶室锁紧机构

# CAB LOCK LONG HAUL CAB

长途运

序号
NO

k

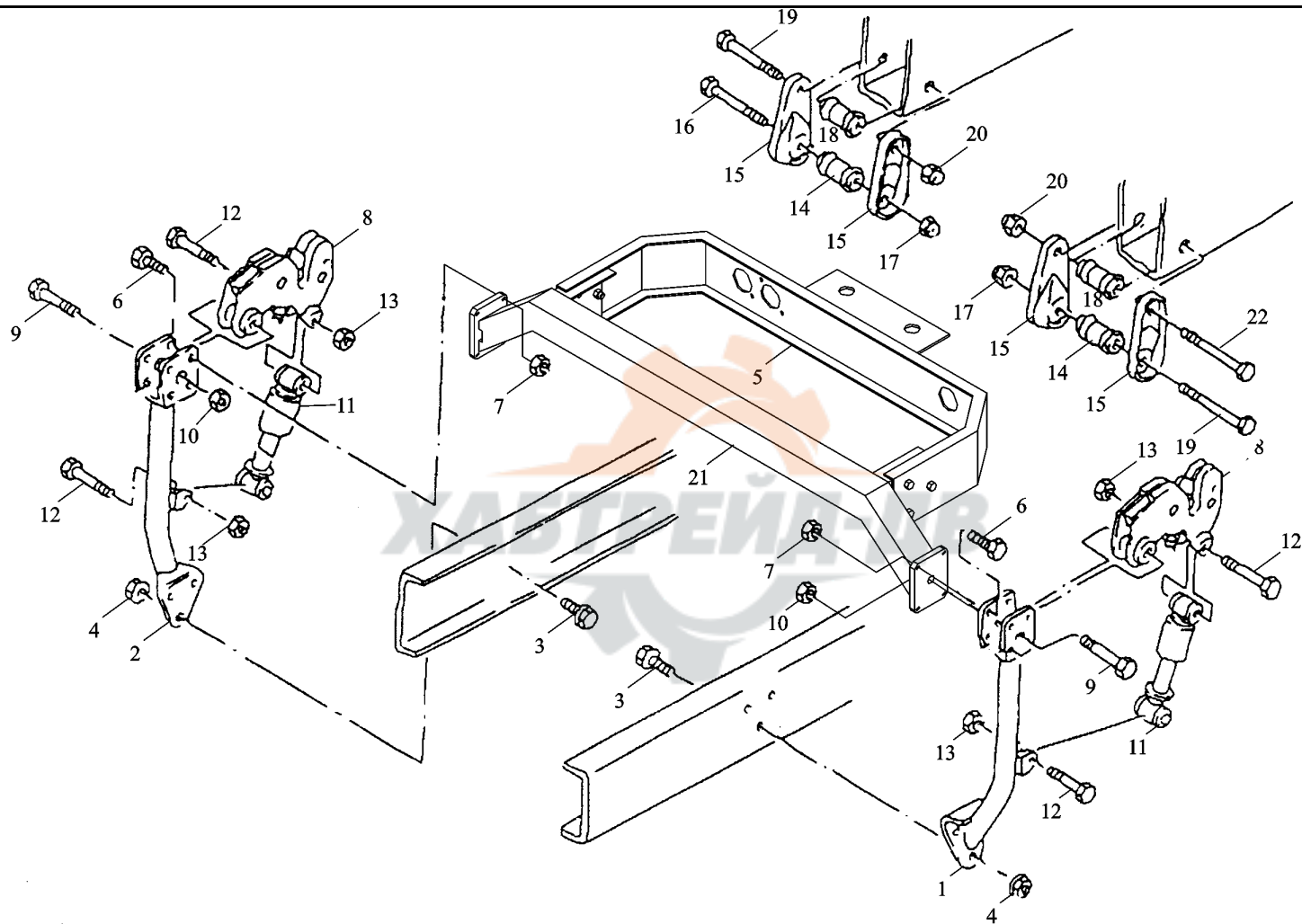

1	81.41701.5344	左后悬置支架总成	Cab support assembly	1		
	DZ1640440020	左后悬置支架总成	Cab support assembly	1		适用车架 780
	DZ1642440060	左后悬置支架总成	Cab support assembly	1		
	DZ1643440020	左后悬置支架总成	Cab support assembly	1		加长 100
2	81.41701.5345	右后悬置支架总成	Cab support assembly	1		
	DZ1640440010	右后悬置支架总成	Cab support assembly	1		
	DZ1642440050	右后悬置支架总成	Cab support assembly	1		
	DZ1643440010	右后悬置支架总成	Cab support assembly	1		适用车架 780
3	Q150B1440	六角头螺栓	Hex lock screw	6		
4	Q33414	I 型全金属六角锁紧螺	Hex lock nut	6		加长 100
5	DZ1640440036	母	Cross member assembly	1		
	DZ1640440045	固定横梁总成	Cross member assembly	1		
	DZ1642440055	固定横梁总成	Cross member assembly	1		
	DZ1643440030	固定横梁总成	Cross member assembly	1		
6	Q150B1225	固定横梁总成	Hex bolt low type	8		
7	Q33412	六角头螺栓	Hex lock nut	8		
8	81.61851.6020	I 型全金属六角锁紧螺	Cab lock	2		
9	Q150B1690	母	Hex shoulder stud	2		用于玉柴发动机
10	Q33416	驾驶室锁	Hex lock nut	2		M12×1.5×22-M8.8-A3C
11	81.41722.6013	六角头螺柱	Spring strut	2		BM12×1.5-8-MAN183-B1
12	Q150B1470	I 型全金属六角锁紧螺	Hex bolt	4		
13	Q33414	母	Hex lock nut	4		M16×1.5×90-8
14	81.96210.0462	减震器	Rubber pad	2		
15	81.61851.0008	六角头螺栓	Striker plate	4		
16	Q150B1470	I 型全金属六角锁紧螺	Hex bolt	2		M14×1.5×65-8.8-MAN183-B1

# 长途运输驾驶室锁紧机构

# CAB LOCK LONG HAUL CAB

长途运

序号
NO

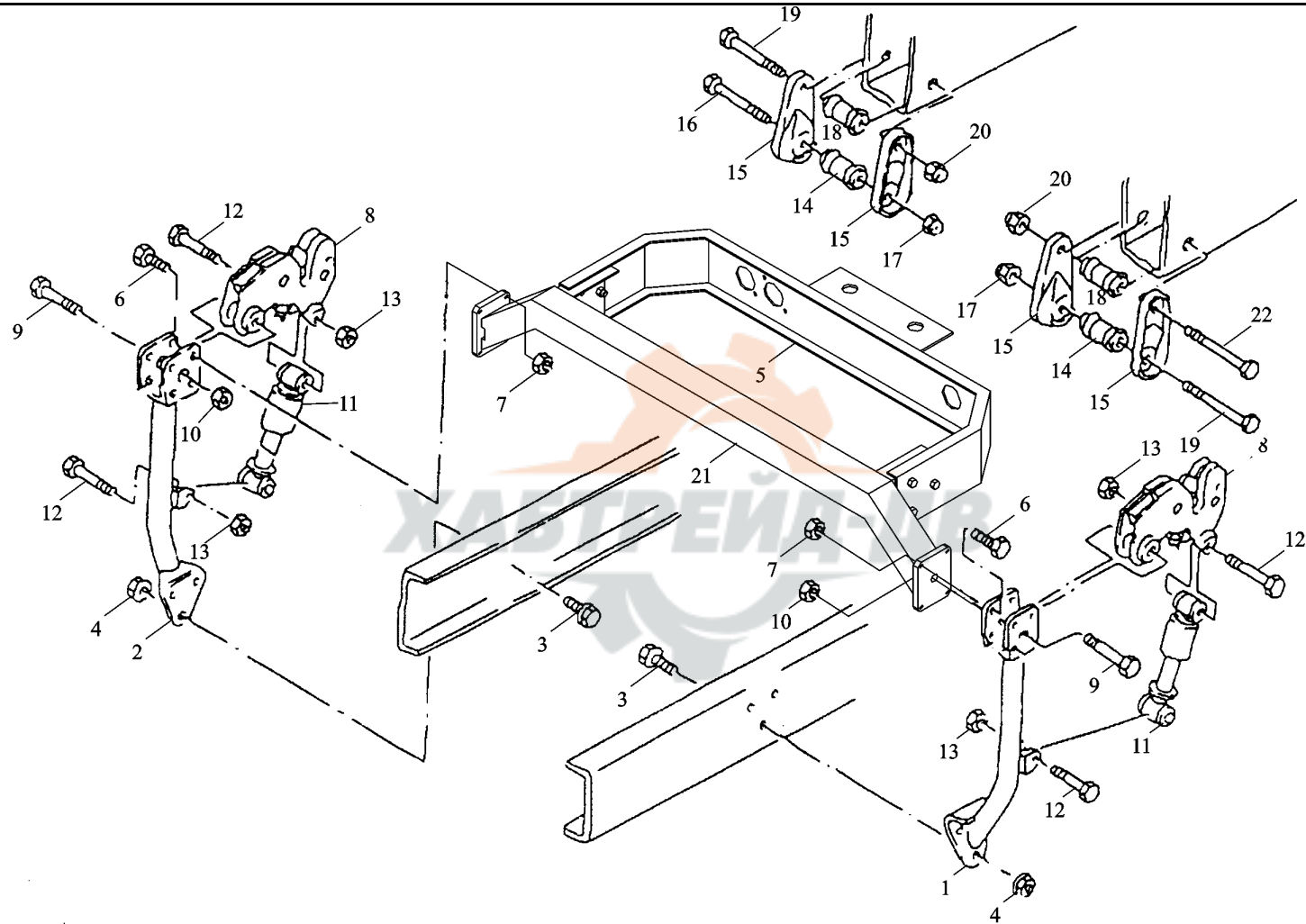

k



17	Q33414	I 型全金属六角锁紧螺	Hex lock nut	1		AM14×1.5-10-MAN183-B1
18	81.96210.0364	母	Silent block	2		
19	Q150B16110	套 筒	Hex shoulder stud	2		M16×1.5×110-8.8-A3C
20	Q33416	六角头螺柱	Hex lock nut	2		AM16×1.5-10-A3C
21	DZ1643440070	I 型全金属六角锁紧螺 母 U型横梁总成	Cross member assembly	1		牵引车用



# 驾驶室液压翻转系统 CAB HYDRAULIC TILTING EQUIPMENT

驾驶  
序号  
NO

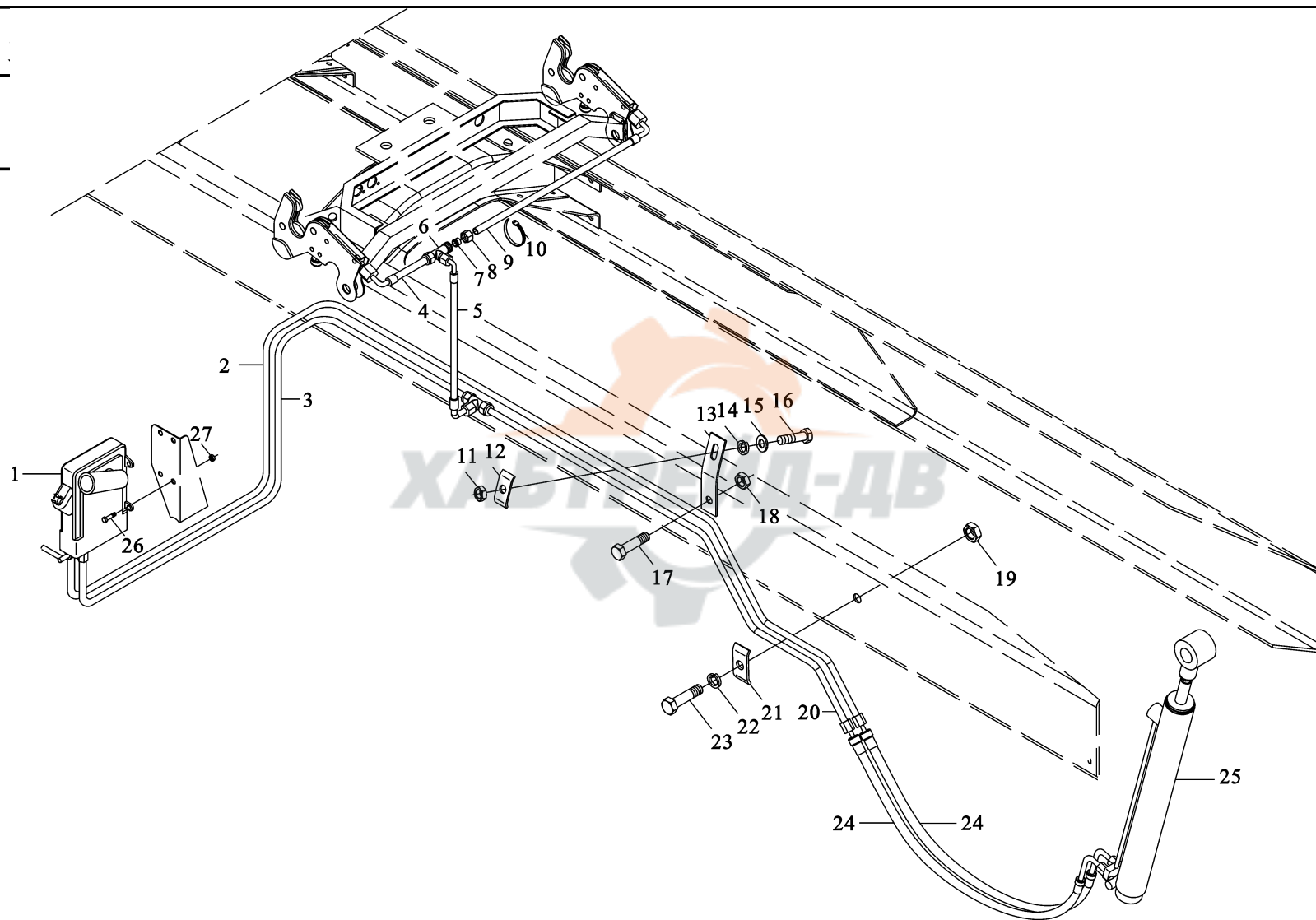

1	81.41723.6059	手□液□升□	Hydraulic manual pump	1		
	DZ16.4082.002	□□液□□升□	Hydraulic electrical pump	1		
2	8	□油管	Oil feeding pipe	1		
3	DZ1643820001	□油管	Oil feeding pipe	1		
4	DZ1643820003	高□□管	High pressure hose	1		
5	DZ1643820006	高□□管	High pressure hose	1		
6	99112820005	卡套式三通管接□	Three joint	2		
7	90003559482	卡套	Clip	6		
8	9003559561	管接□ 螺螺母	Nut	6		
9	90003559516	高□□管	High pressure hose	1		
10	DZ1643820005	塑料□固□	Plastic fastening strap	4		
11	90003171356	I型六角螺母	Nut	2		
12	Q340B06	固定板	Plate	2		
13	93.760081	支架	Bracket	2		
14	2190-3506511	重型□簧□圈	Spring washer	2		
15	Q40506	大□圈	Washer	2		
16	Q40206	六角□螺栓	Hex screw	2		
17	Q150B0625	六角□螺栓	Hex screw	2		
18	Q150B1030	II型全金属六角□□螺	Locking nut	4		
19	Q33210	母	Nut	1		
20	Q340B08	I型六角螺母	Oil feeding hose	1		
21	DZ1643820002	□油管	Plate	1		
22	DZ1643820021	固定板	Spring washer	1		
23	Q40308	□簧□圈	Hex screw	1		
24	Q150B0825	六角□螺栓	High pressure hose	2		

# 驾驶室液压翻转系统 CAB HYDRAULIC TILTING EQUIPMENT

驾驶  
序号  
NO

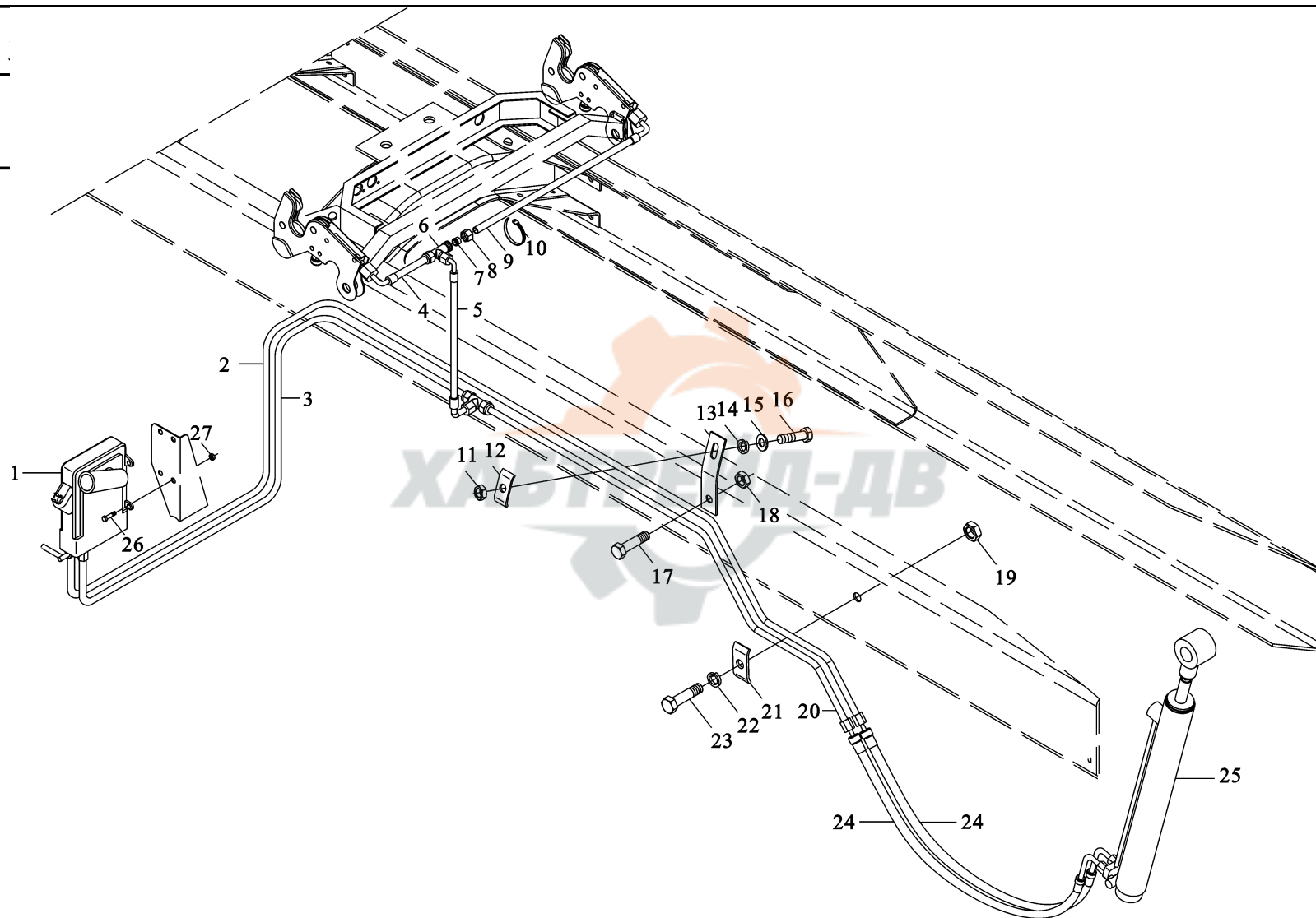

25	81.41723.6099	翻斗 油缸	Tilting cylinder	1		
26	06.02813.4410	六角紧锁螺钉	Hex lock screw	4		M10×25-10.9-MAN183-B1
27	06.11251.2001	六角紧锁螺母	Hex lock nut	4		M10-10-MAN183-B1



左翼子板 LEFT FENDER

左  
序

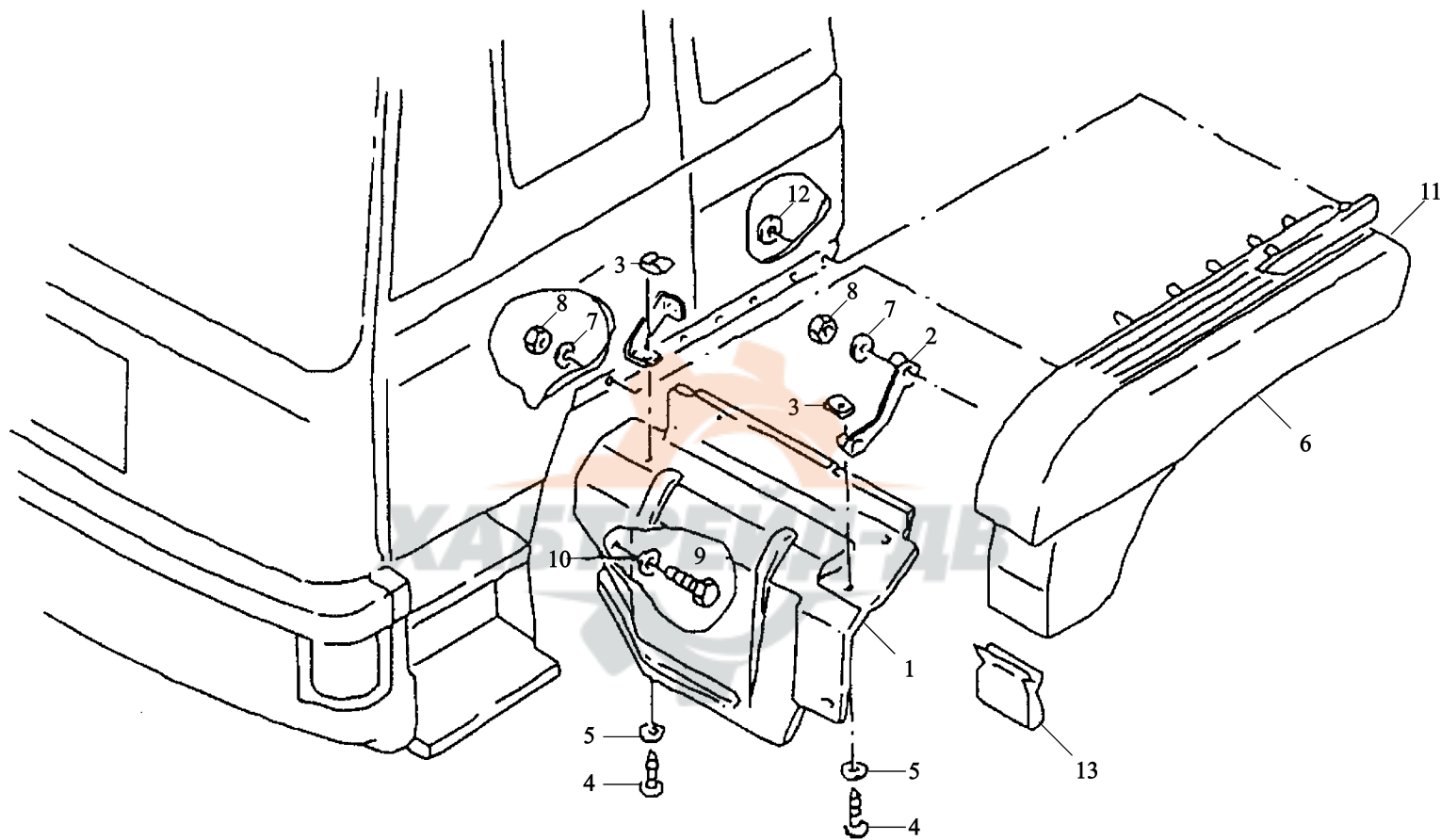

1	81.61230.0067	左前挡泥板	Guard plate left wide	1	
2	81.61243.0095	角 架	Angle bracket left	1	
3	06.13189.0078	螺 母	Speed nut	2	ST6.3-5-SW
4	06.07154.1804	椭圆型自攻螺钉	Oval-head self-tapping	4	ST6.3×16C-H-A3C
5	06.15190.0307	垫 圈	screw	4	
6	81.61210.5363	左前翼子板	Washer	1	
7	06.15190.0309	垫 圈	Mudguards assembly left	7	8.4×24×2-140HV-MAN183-B1
8	06.11184.0114	六角螺母	Washer	7	M8-8-A2C
9	06.07158.1805	椭圆型自攻螺钉	Hexagon nut	2	ST6.3×19C-H-A3R
10	06.15190.0307	垫 圈	Oval-head self-tapping	2	6.4×18×1.6-140HV-MAN183-B1
11	81.61210.0173	左翼子板装饰板	screw	1	
12	06.41159.0050	锁紧垫片	Washer	4	5-18-CK67/PVC-SW
13	81.97640.0278	U型夹	Mudguard trim plate left	1	
			Lock washer		
			Clamp		

# 右翼子板 RIGHT FENDER

右翼子板 R

序号 NO	件号 Part.No
----------	---------------

备注 Remark
--------------

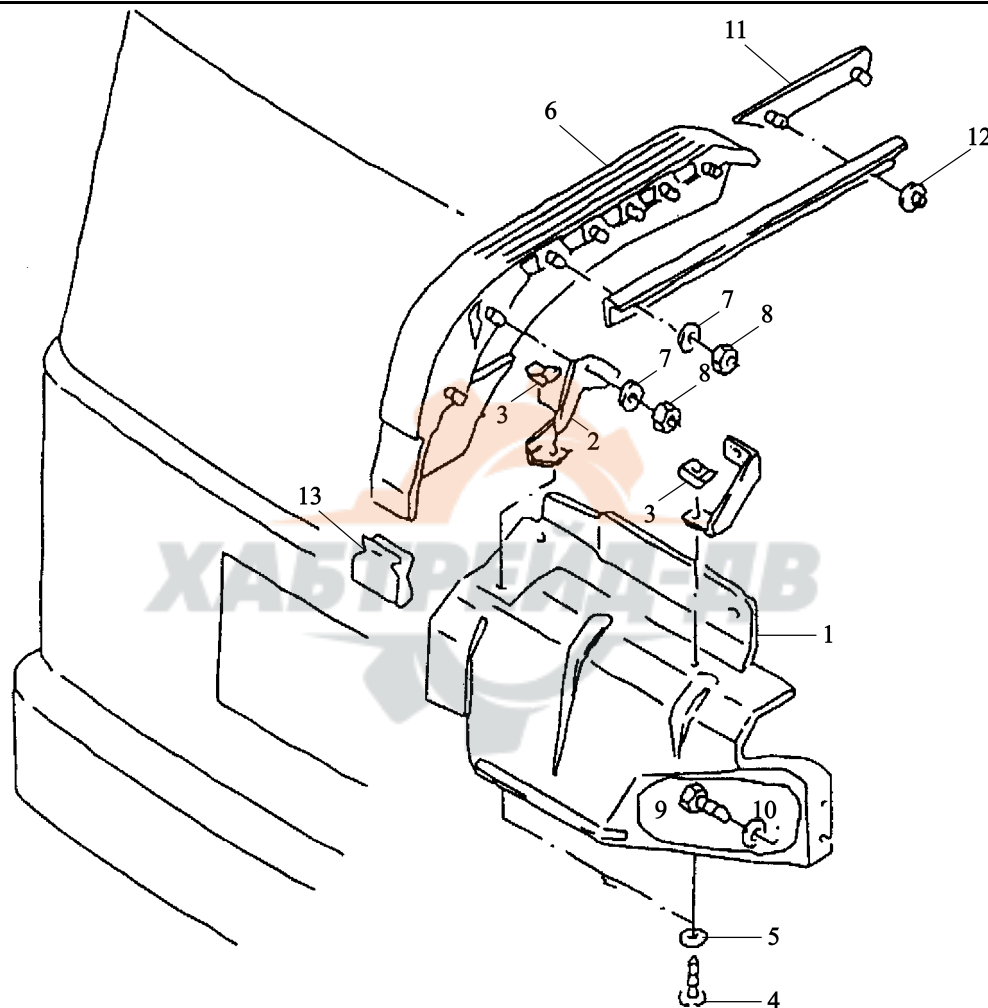



1	81.61230.0066	右前挡泥板	Guard plate right wide	1	
2	81.61243.0094	角 架	Angle bracket	1	
3	06.13189.0078	螺 母	Speed nut	2	ST6.3-5-SW
4	06.07154.1804	椭圆型自攻螺钉	Oval-head self-tapping	4	ST6.3×16C-H-A3C
5	06.15190.0307	垫 圈	screw	4	6.4×18×1.6-140HV-MAN183-B1
6	81.61210.5364	右前翼子板	Washer	1	
7	06.15190.0309	垫 圈	Mudguards assembly right	7	8.4×24×2-140HV-MAN183-B1
8	06.11184.0114	六角螺母	Washer	7	M8-8-A2C
9	06.07158.1805	椭圆型自攻螺钉	Hexagon nut	2	ST6.3×19C-H-A3R
10	06.15190.0307	垫 片	Oval-head self-tapping	2	6.4×18×1.6-140HV-MAN183-B1
11	81.61210.0172	右挡泥板装饰板	screw	1	
12	06.41159.0050	锁紧垫圈	Washer	4	5-18-CK67/PVC-SW
13	81.97640.0278	U型夹	Mudguard trim plate right	1	
			Lock washer		
			Clamp		

驾驶室后侧左翼子板 FENDER LEFT BEHIND CAB

驾  
身  
序  
·  
NO

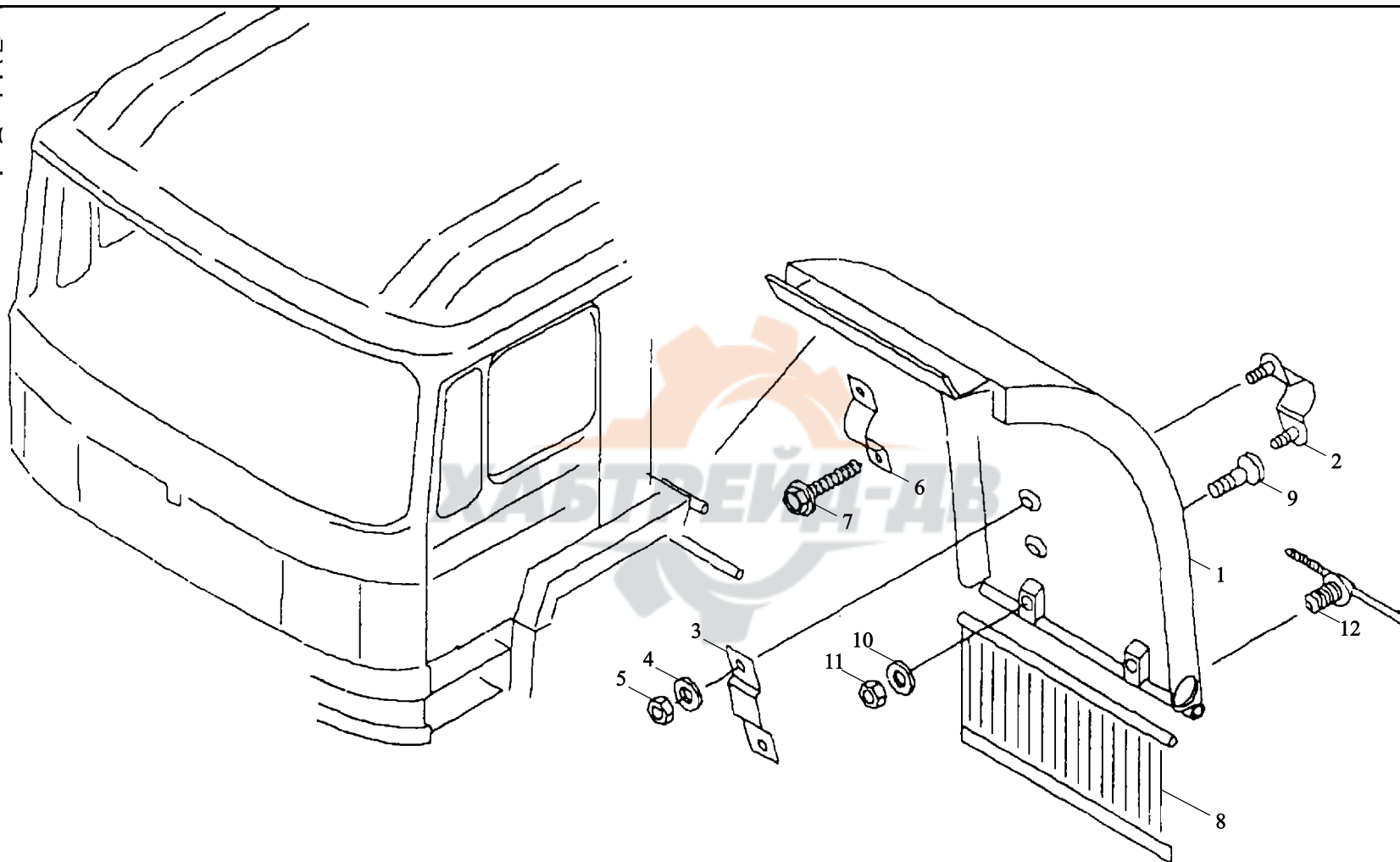

1	81.66410.0352	左后翼子板	Mudguards left rear	1	
2	81.61243.5268	夹片总成	Clip assembly	2	
3	81.61243.0091	搭接板	Fish plate	2	
4	Q40108	垫 片	Washer	4	A8.4×16×1.6-200HV- MAN183-B4
5	Q33408	六角螺母	Hexagon nut	4	M8-8-MAN183-B4
6	81.97445.0208	夹 片	Clip	2	
7	81.90490.0641	带槽六角有环螺栓	Grooved hex collar bolt	4	PTK7×25-WN1447-ST-A2B
8	DZ1640230071	挡泥板	Mud flap	1	
9	Q2540835	沉头螺钉	Countersunk screw	2	M8×35-8.8-A3C
10	Q40108	垫 片	Washer	2	A8.4×16×1.6-200HV- MAN183-B1
11	Q33408	六角螺母	Hexagon nut	2	M8-8-MAN183-B1
12	81.97470.0098	塑料紧固带 (带固定座)	Cable binder with nounting	2	

# 驾驶室后侧右翼子板 FENDER RIGHT BEHIND CAB

驾驶室后

序号	
NO	

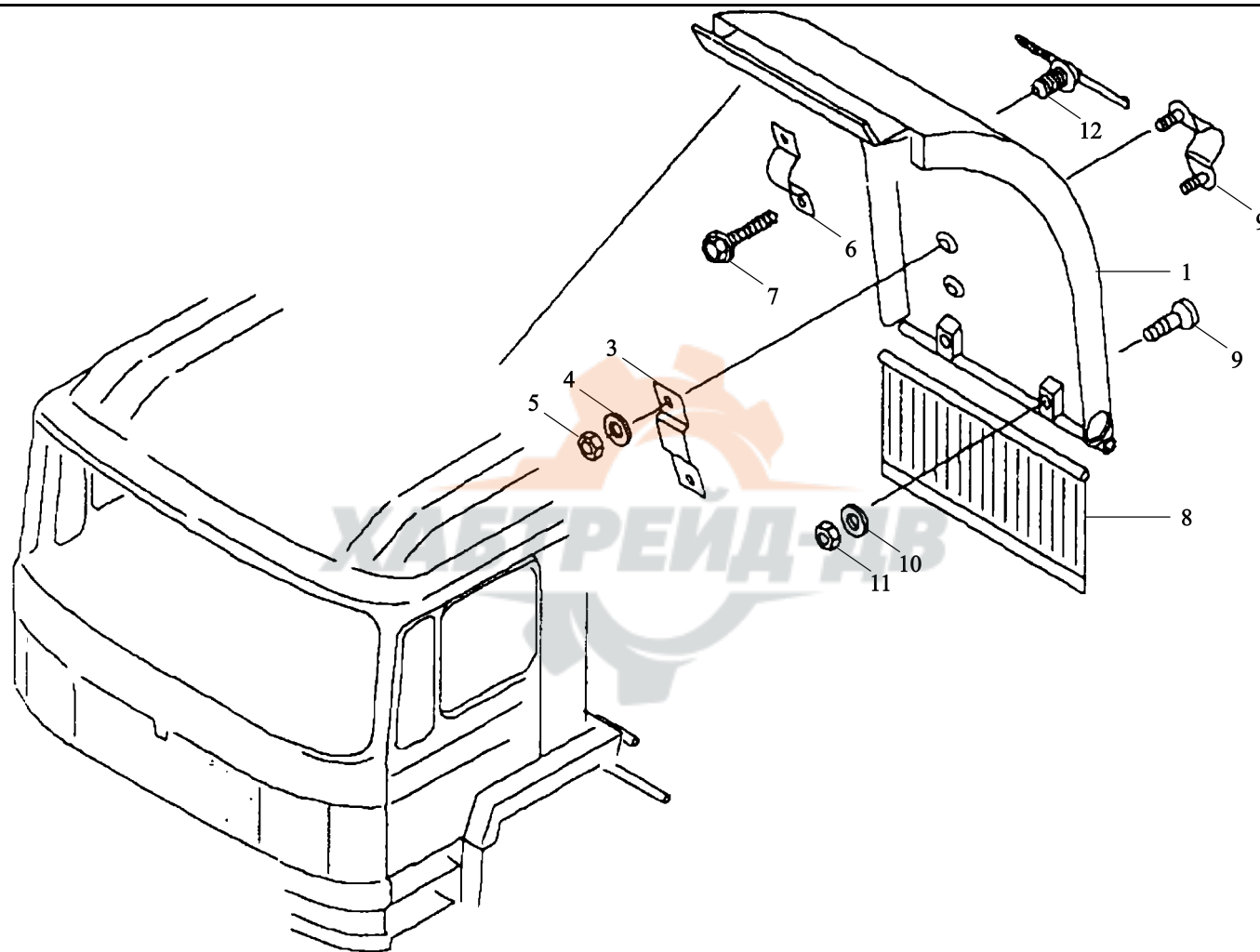

注  
Remark

1	81.66410.0353	右后翼子板	Mudguards right rear	1	
2	81.61243.5268	夹片总成	Clip assembly	2	
3	81.61243.0091	搭接板	Fish plate	2	
4	Q40108	垫 片	Washer	4	A8.4×16×1.6-200HV- MAN183-B4
5	Q33408	六角螺母	Hexagon nut	4	M8-8-MAN183-B4
6	81.97445.0208	夹 片	Clip	2	
7	81.90490.0641	带槽六角方头螺栓	Grooved hex collar bolt	4	PT-K7×25-WN1447-ST-A2B
8	DZ1640230071	挡泥板	Mud flap	1	
9	Q2540835	沉头螺钉	Countersunk screw	2	M8×35-8.8-A3C
10	Q40108	垫 片	Washer	2	A8.4×16×1.6-200HV- MAN183-B1
11	Q33408	六角螺母	Hexagon nut	2	M8-8-MAN183-B1
12	81.97470.0098	塑料紧固带 (带固定座)	Cable binder with mounting	2	

# 左门台阶 LEFT DOOR STEP

左门台阶 1

序号 NO	件号 Part.N
----------	--------------

备注 Remark
--------------

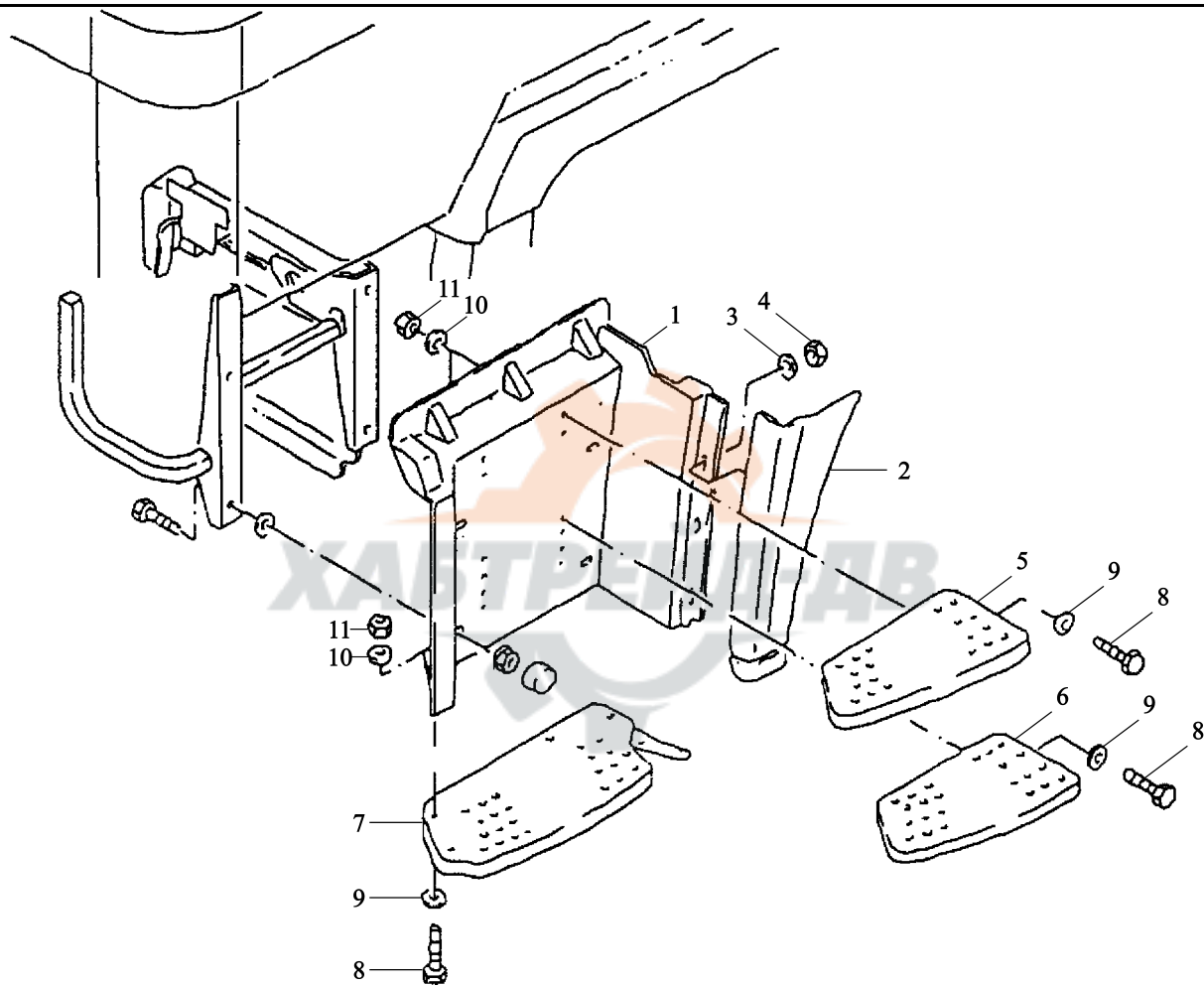

1	81.61510.0225	左门台阶	Step left	1	高位踏板
	81.61510.0229	左门台阶	Step left	1	低位踏板
2	81.61510.5161	左装饰件总成	Trim assembly left	1	高位踏板
	81.61510.5163	左装饰件总成	Trim assembly left	1	低位踏板
3	06.15190.0409	垫 片	Washer	3	8.4×24×2-140HV-MAN183-B4
4	06.11069.0158	螺 母	Hexagon nut	3	M8-8-MAN183-B4
5	81.61510.0267	左上台阶	Step left upper	1	
6	81.61510.0263	左中间台阶	Step center	1	
7	81.61510.5197	左下台阶总成	Step assembly right lower black	1	高位踏板 HIGH POSITION
	81.61510.5181	下台阶	Step	1	
8	06.01320.1314	螺 栓	Hex bolt	14	STEP
9	06.15019.0084	垫 片	Washer	14	低位踏板 LOWER STEP
10	06.15190.0409	垫 片	Washer	14	M8×22-8.8-MAN183-B4
11	06.11069.0158	螺 母	Hexagon nut	14	A8.4×16×1.6-200HV- MAN183-B4 8.4×24×2-140HV-MAN183-B4 M8-8-MAN183-B4

右门台阶 RIGHT DOOR STEP

右门台阶 RIGI

序号 NO	件号 Part.No
----------	---------------

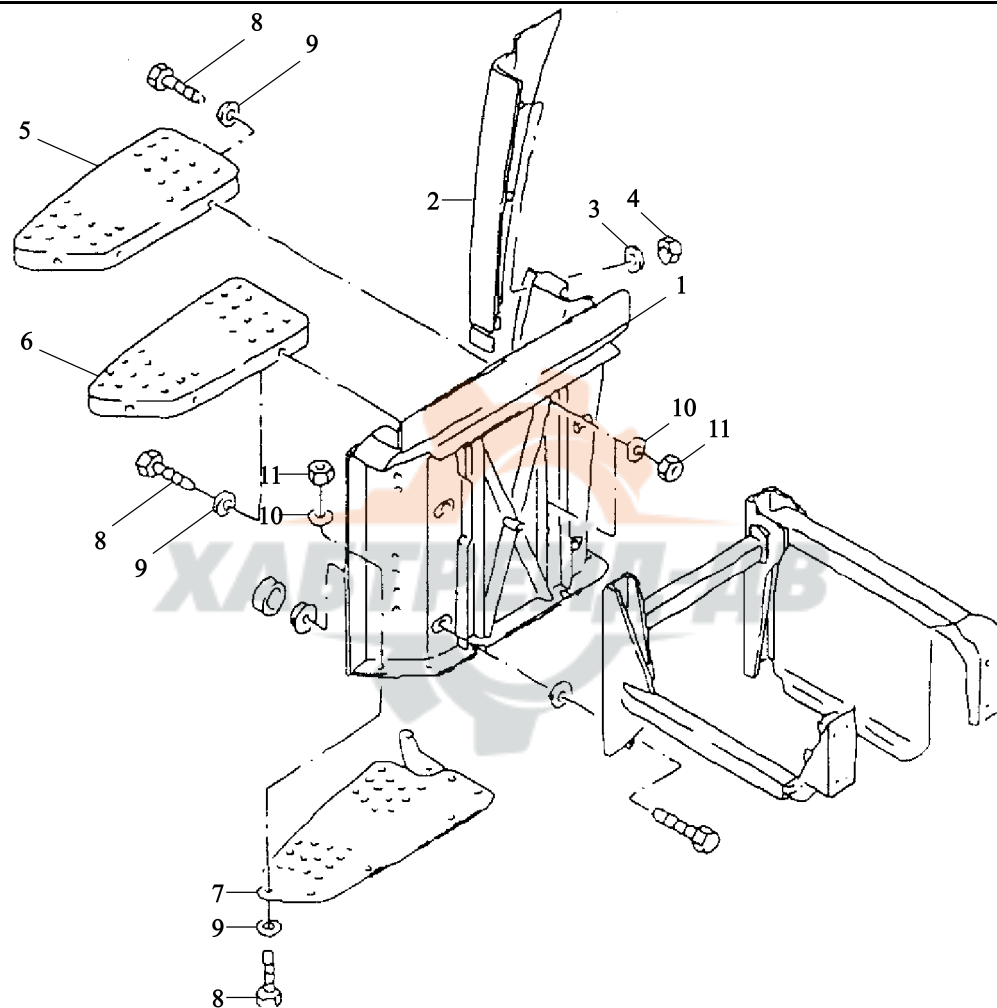

备注 Remark
--------------



1	81.61510.0226	右门台阶	Step right	1	高位踏板
	81.61510.0230	右门台阶	Step right	1	低位踏板
2	81.61510.5162	右装饰件总成	Trim assembly right	1	高位踏板
	81.61510.5164	右装饰件总成	Trim assembly right	1	低位踏板
3	06.15190.0309	垫 片	Washer	3	8.4×24×2-140HV-MAN183-B4
4	06.11069.0114	螺 母	Hexagon nut	3	M8-8-MAN183-B4
5	81.61510.0268	右上台阶	Step right upper	1	
6	81.61510.0262	右中间台阶	Step center	1	
7	81.61510.5196	右下台阶	Step assembly right lower black	1	高位踏板 HIGH POSITION
	81.61510.5181	下台阶	Step	2	
8	06.01320.1314	螺 栓	Hex bolt	14	STEP
9	06.15019.0081	垫 片	Washer	14	低位踏板 LOWER STEP
10	06.15190.0309	垫 片	Washer	14	M8×22-8.8-MAN183-B4
11	06.11069.0114	螺 母	Hexagon nut	14	A8.4×16×1.6-200HV- MAN183-B4 8.4×24×2-140HV-MAN183-B4 M8-8-MAN183-B4

后挡板护盖

COVERING FOR REAR PANEL

后挡板护盖

序号	件号
NO	Part.N

备注  
Remark

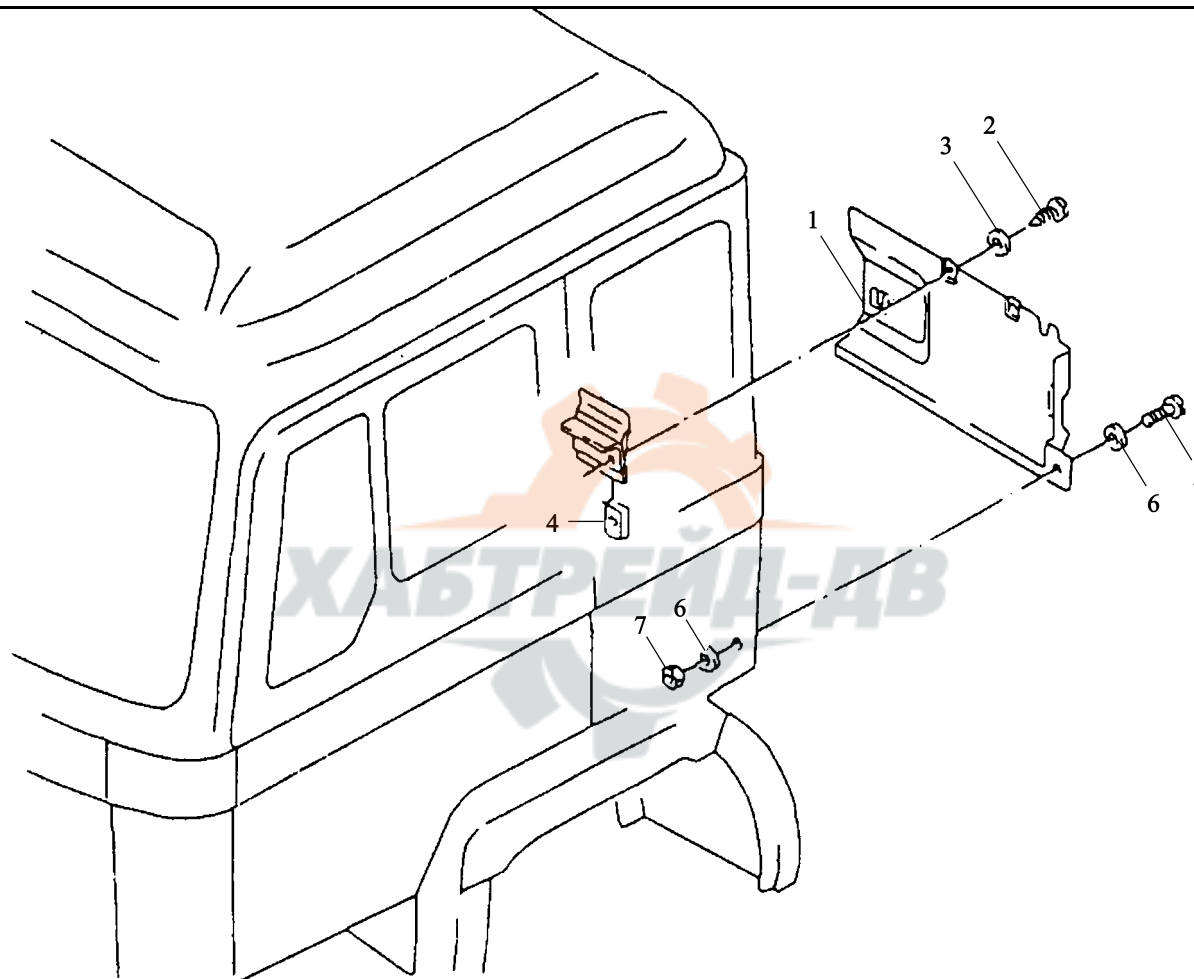

1	81.62710.0002	左后护盖	Covering for rear panel	1		
2	06.07154.4504	自攻螺钉	Oval-head self-tapping	2		ZX16Z1-C-H-ASR
3	06.15199.0006	垫圈	screw	2		5.3×15×1.2-140HV-A3R
4	06.13189.0058	簧片螺母	Washer	2		ST4.2-8-CK67-A3C
5	06.04209.0015	盘头螺钉	Speed nut	1		ST4.2-8-CK67-A3C
6	06.15199.0004	垫圈	Pan-head screw	2		M6×20-4.8-H-A3R
7	06.11240.0203	六角锁紧螺母	Washer	1		AM6-8-MAN183-B1
			Hex lock nut			



驾驶室后拦板上的扶手

GRAB HANDLE ON REAR PANEL TRUCK TRACTOR

驾驶室后拦

序号	件号
NO	Part.N

备注  
Remark

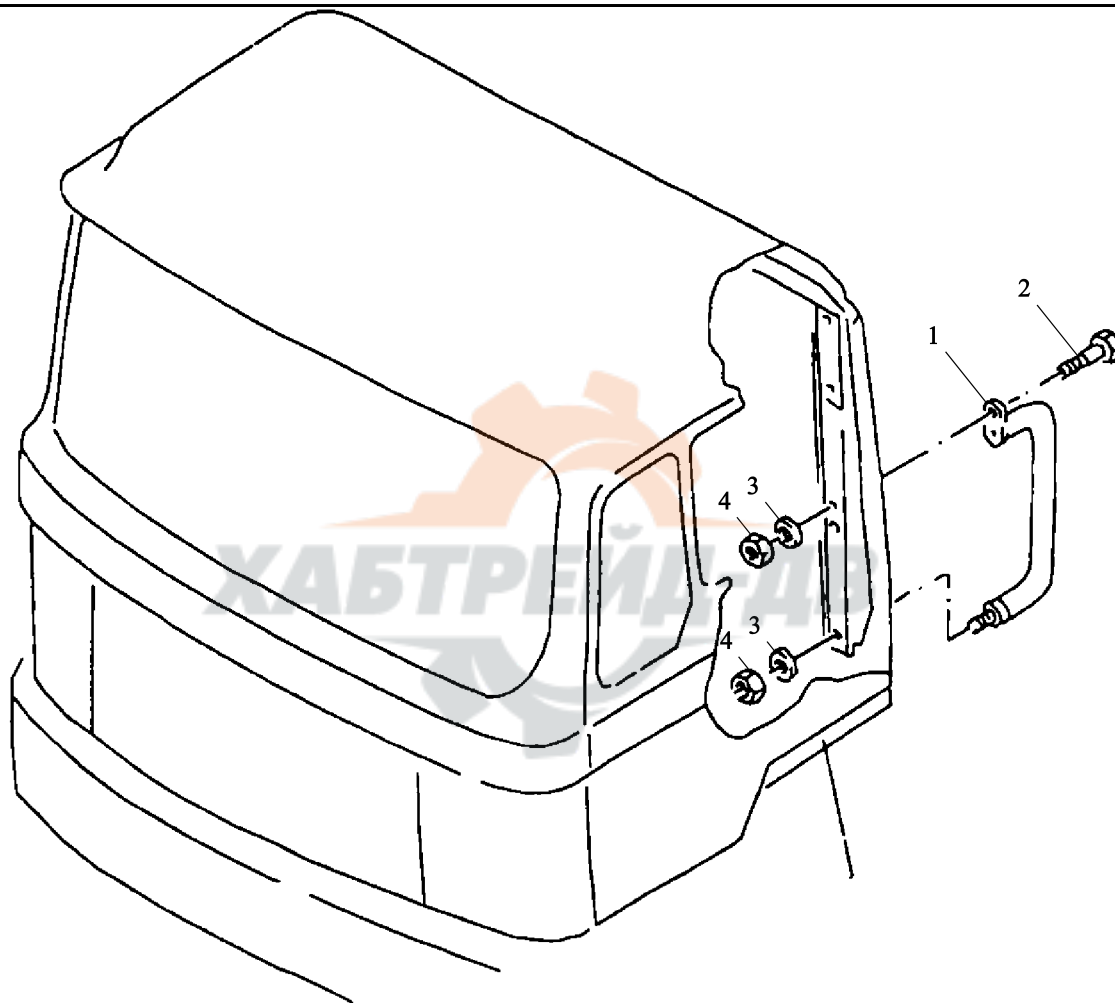

1	81.97001.5085	黑色扶手总成	Grab handle assembly black	1		
2	06.01303.3113	六角螺栓	Hex bolt	2		M8×20SC-8.8MAN183-B1
3	06.15013.0411	垫 片	Washer	3		A8.4×16×1.6-200HV- MAN183-B1
4	06.11064.2114	六角螺母	Hexagon nut	1		M18-8-MAN183-B1



# 前侧装饰板和保护边 SIDE TRIM FRONT PANEL AND PROTECTIVE EDGING

前侧装饰板

序号 NO	件 Pa
----------	---------

备注  
Remark

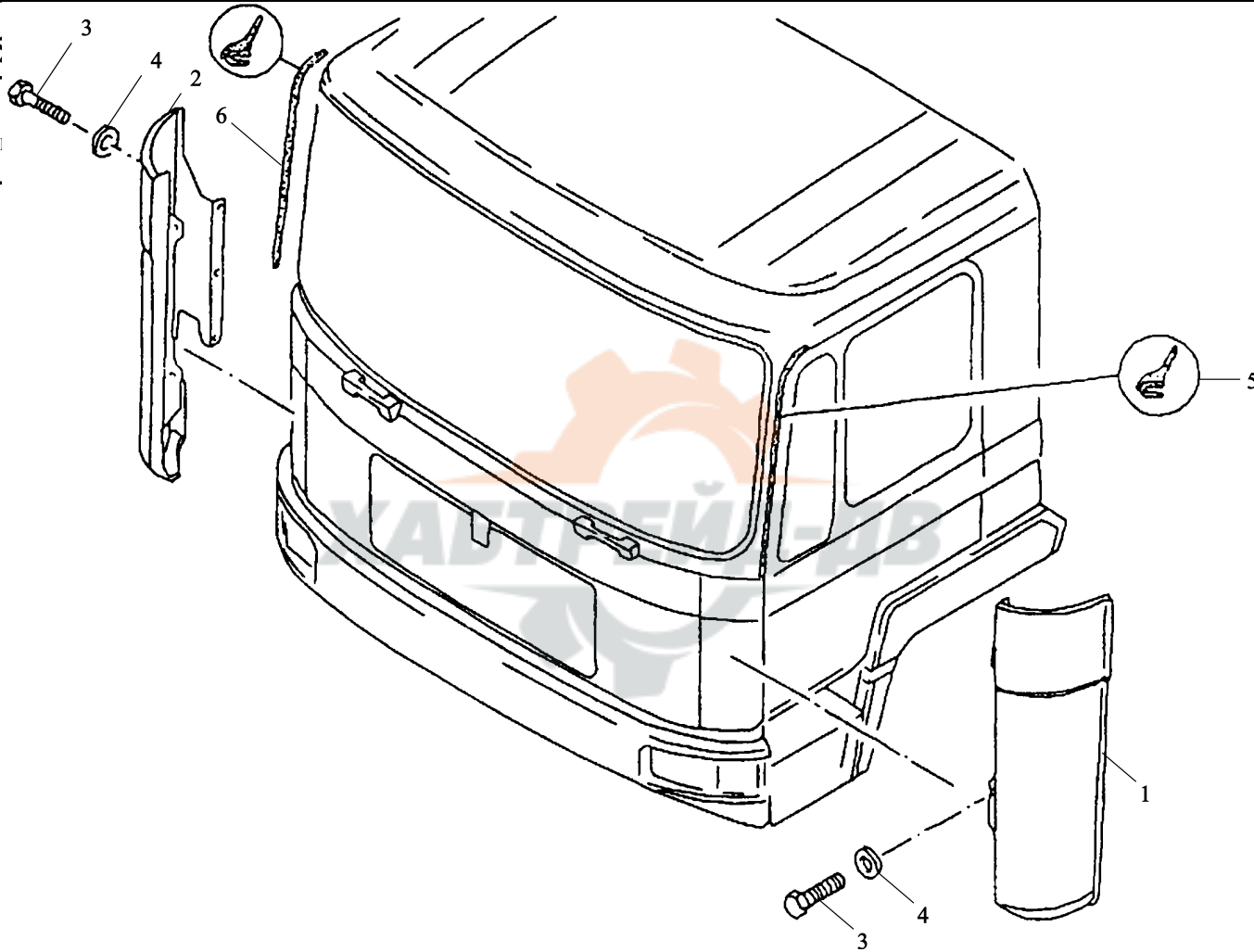

1	81.62410.2225	左前侧盖板	Side trim for front panel left	1		
2	81.62410.2224	右前侧盖板	Side trim for front panel right	1		
3	06.01470.0509	六角头螺栓	Hex bolt	10		M18×16Z1-8.8-MAN183-B1
4	06.15013.6111	垫 圈	Washer	10		A8.4×16×1.6-200HV-A3C
5	81.62910.0051	雨槽护套左	Left drain strap	1		
6	81.62910.0052	雨槽护套右	Right drain strap	1		



# 遮阳板滚子 SUN VISOR ROLLER

遮阳板滚

序号	
NO	

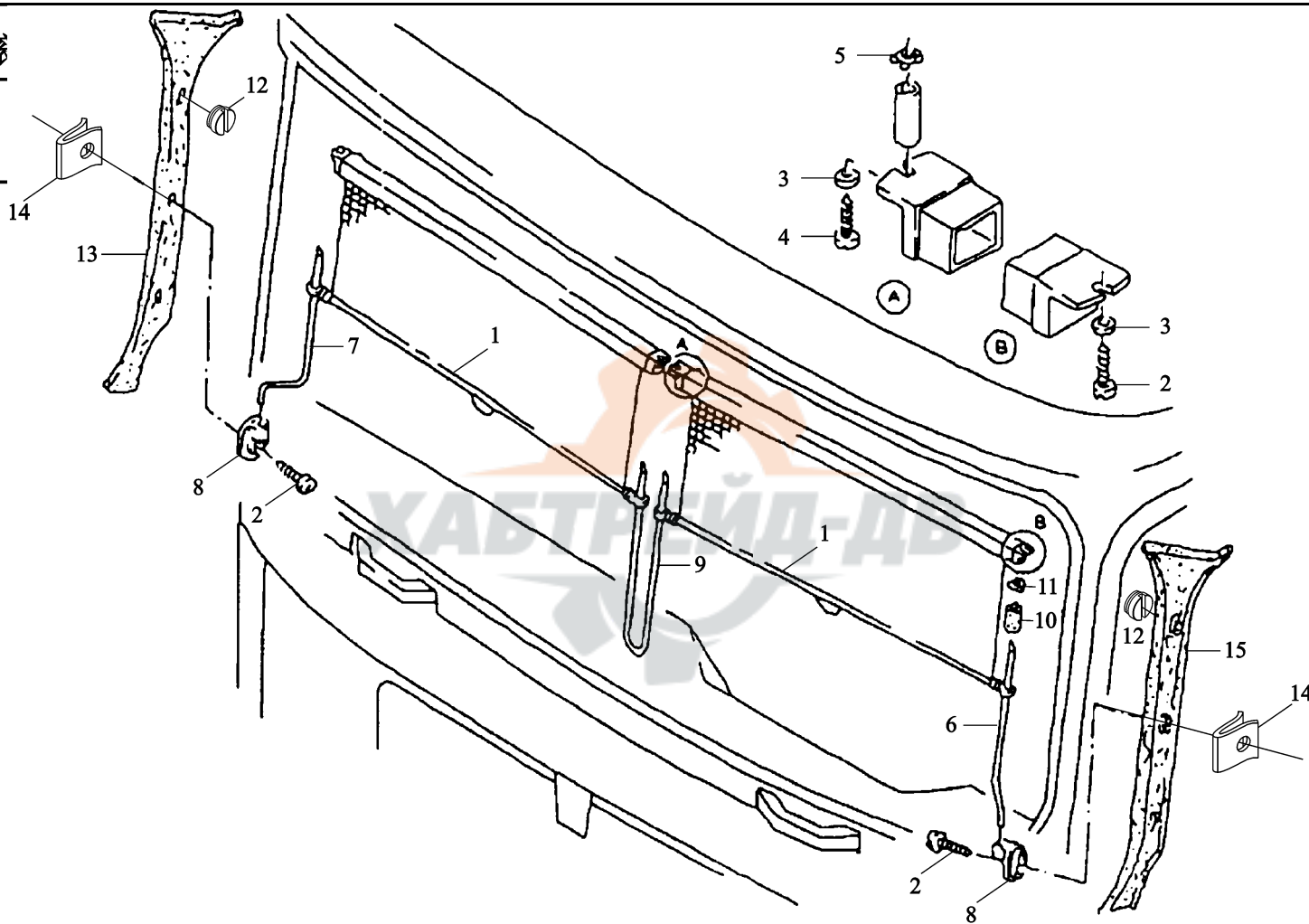

注  
mark



1	81.63703.6019	遮阳卷帘	Roller sun visor	2	
2	06.07158.1607	自攻螺钉	Oval-head self-tapping	4	ST4.8×25C-H-A3R
3	06.15199.0006	垫圈	screw	4	5.3×15×1.2-140HV-A3R
4	06.07158.1609	自攻螺钉	Washer	2	ST4.8×38C-H-A3R
5	06.13189.0025	簧片螺母	Oval-head self-tapping	2	ST4.8-1-A3C
6	81.63703.0049	左导向杆	screw	1	
7	81.63703.0050	右导向杆	Speed nut	1	
8	81.63703.0051	固定架	Guide rod left	2	
9	81.63703.0048	中间导向杆	Guide rod right	1	
10	81.96020.0192	缓冲器	Holder	4	
11	81.90820.0153	锁片	Guide rod center	4	
12	81.96002.0303	塞子	Buffer	4	D34×24×4
13	81.62430.0017	左上护罩	Lock	1	
14	06.13189.0039	簧片螺母	Plug	4	ST4.2-3-A3C
15	81.62430.0016	右上护罩	Covering left, upper	1	
			Speed nut		
			Covering right, upper		

# 环形窗帘和横向窗帘 AIL-ROUND CURTAIN AND TRARISVERSE CURTAIN

## 环形窗帘和

序号 NO	件 Part
----------	-----------

备注  
Remark

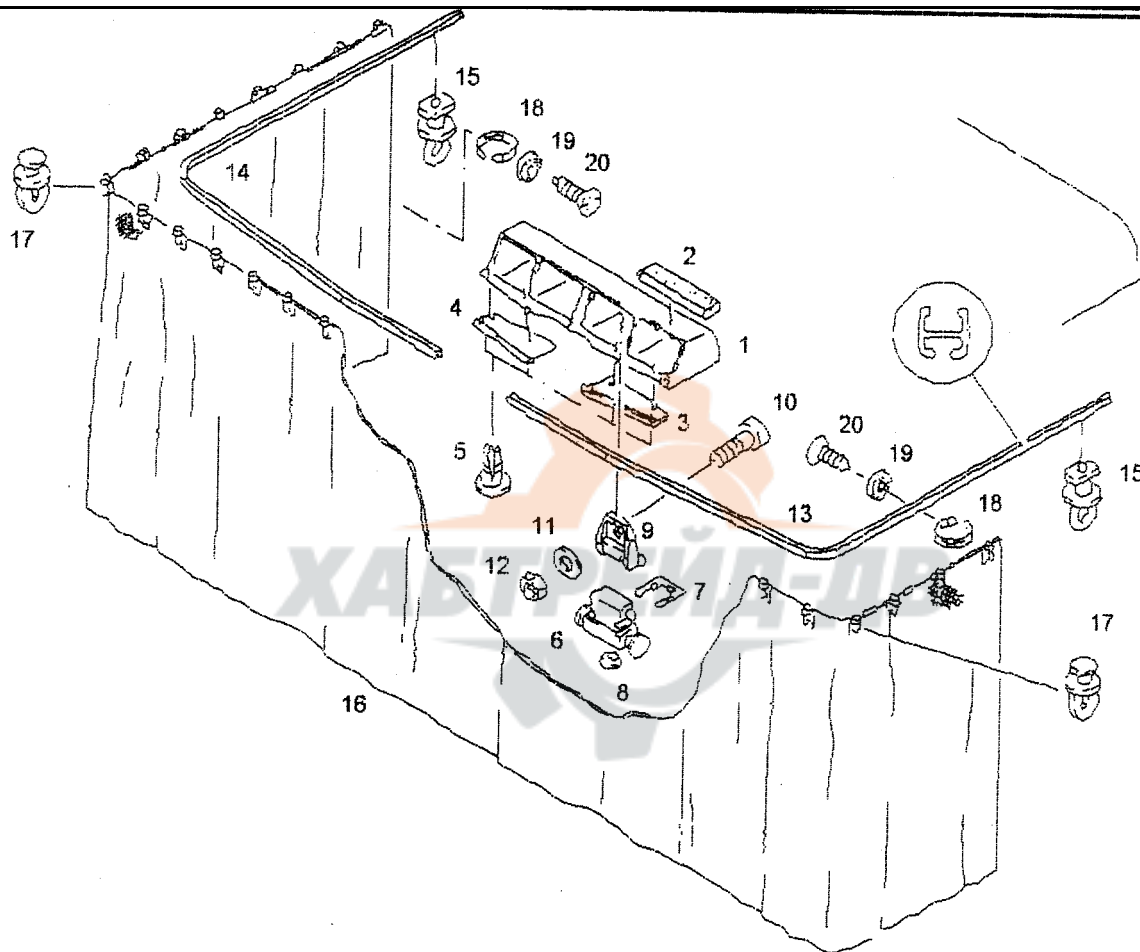

1	81.63903.0078	窗帘盒	Curtain tray	1		Cral9011
2	81.63903.0134	黑色粘式缓冲垫	Buffer self-adhesive black	2		60×25×12
3	81.63903.0132	黑色直角铁	Angle right black	1		
4	81.63903.0133	黑色左角铁	Angle left black	1		
5	06.24249.0007	铆 钉	Rivet	5		7×3×17.5-4-PA6.6-SW
6	81.61444.0013	转动锁总成	Turn lock assembly	1		
7	81.61440.0016	塑料夹箍	Clamp plastic	1		
8	81.97104.0012	盖	Cover	1		
9	81.61440.0018	锁紧板	Lock plate	1		
10	06.04201.2507	六角头带垫螺栓	Pan-head screw	1		M5×16-4.8-H-MAN183-B1
11	06.15013.0408	垫 片	Washer	2		A5.3×10×1-200HV-MAN183-B1
12	06.11064.2111	六角螺母	Hexagon nut	1		M5-8-MAN183-B1
13	81.63704.0013	左轨道（基本型不用）	Rail left	1		
14	81.63704.0014	右轨道（基本型不用）	Rail right	1		
15	06.43839.0026	夹持器（基本型不用）	Retainer	2		
16	81.62101.5060	环形窗帘（基本型不用）	Ail-round curtain	1		
	81.62101.5063	环形窗帘总成（基本型不用）	Ail-round curtain assy	1		
17	06.43839.0060	滑 块	Glider	44		
18	81.62105.5001	固定带	Retaining strap	2		
19	81.62105.0001	固定带	Retaining disc	6		
20	06.07158.1406	固定带 自攻螺钉	Oval-head self-tapping screw	6		ST3.9×22C-H-A3R

横向窗帘 TRANSVERSE CURTAIN

横向窗帘

序号 NO	件 Part
----------	-----------

备注  
Remark

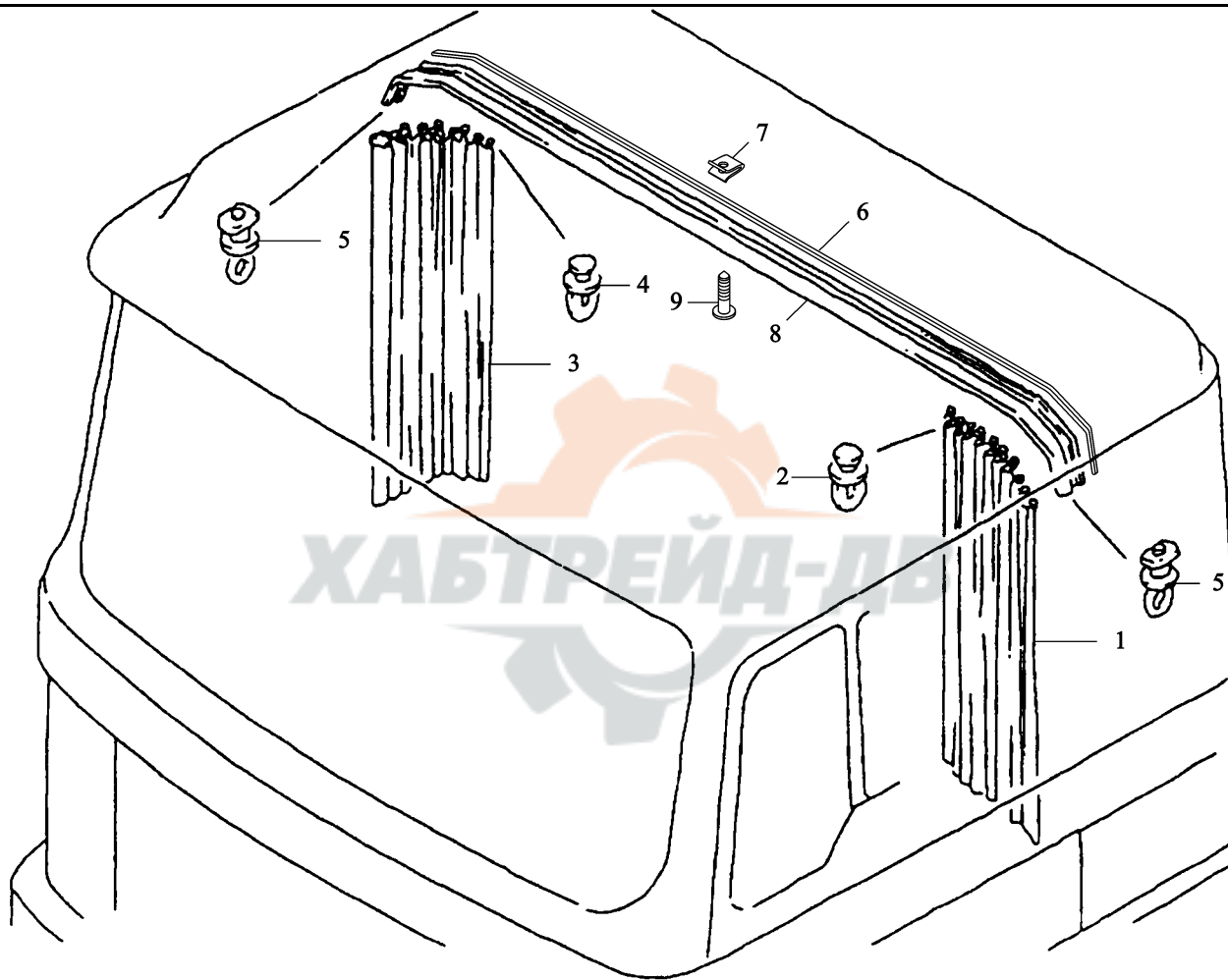

1	81.62101.5067	左窗帘总成	Transverse curtain assembly left	1		
2	06.43839.0060	滑 块	Glider	16		
3	81.62102.5050	右窗帘总成	Transverse curtain assembly right	1		
4	06.43839.0060	滑 块	Glider	16		
5	06.43839.0026	夹持器	Retainer	2		
6	81.62140.0065	窗帘轨道	Curtain rail	1		
7	06.13189.0059	螺 母	Speed nut	15		
8	04.39835.9012	黑色嵌条垫	Filler stripmat black	2.4		
9	06.07154.1204	十字槽盘头自攻螺钉	Self tapping	15		

# 行李架 LUGGAGE RACK

## 行李架

序号
NO

注  
ark

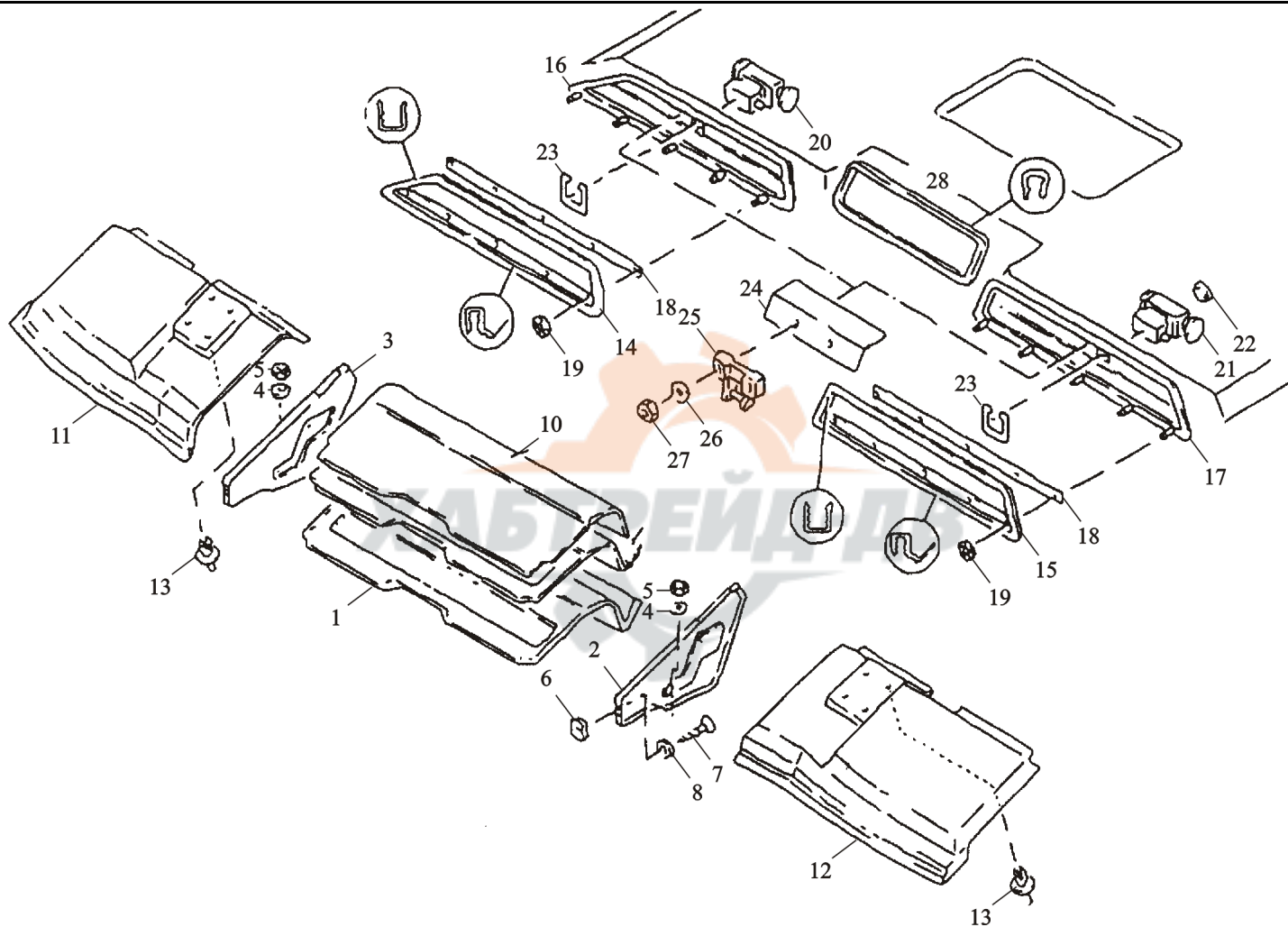

	81.63903.5073	中间衬板	Intermediate panel			用于高顶 包含 1~3 件
	81.63903.5074	中间衬板	Intermediate panel	1		
1	81.63903.0079	中间衬板	Intermediate panel	1		用于低顶 包含 1~3 件
2	81.63903.0167	中间衬板	Intermediate panel	1		
3	81.63903.0166	中间衬板	Intermediate panel	1		
4	06.15013.0409	垫 片	Washer	2		
5	06.11018.0112	六角螺母	Hexagon nut	2		A6.4×12×1.6-200HV- MAN183-B1
6	06.13189.0025	螺 母	Speed nut	4		
7	06.07159.0012	椭圆头自攻螺钉	Oval-head self-tapping screw	4		
8	06.15013.6108	垫 片	Washer	4		
9	81.63903.0089	下内镶板	Washer	1		A5.3×10×1-200HV-A3C
10	81.63903.0153	上 / 中间内镶板	Interior paneling center part, lower	1		
11	81.63903.0090	右上内镶板	Interior paneling upper/center	1		
	81.63903.0130	右上内镶板	Interior paneling right, upper	1		
12	81.63903.0155	右上内镶板	Interior paneling right, upper	1		
	81.63903.0131	左内镶板	Interior paneling left	1		
13	06.24249.0007	左内镶板	Interior paneling left	4		高顶
14	81.63903.0080	铆 钉	Rivet	1		7×3×17.5-4-PA6.6-SW
15	81.63903.0081	右密封架	Sealing frame right	1		
16	81.63903.5042	左密封架	Sealing frame left	1		

# 行李架 LUGGAGE RACK

## 行李架

序号
NO

注  
ark

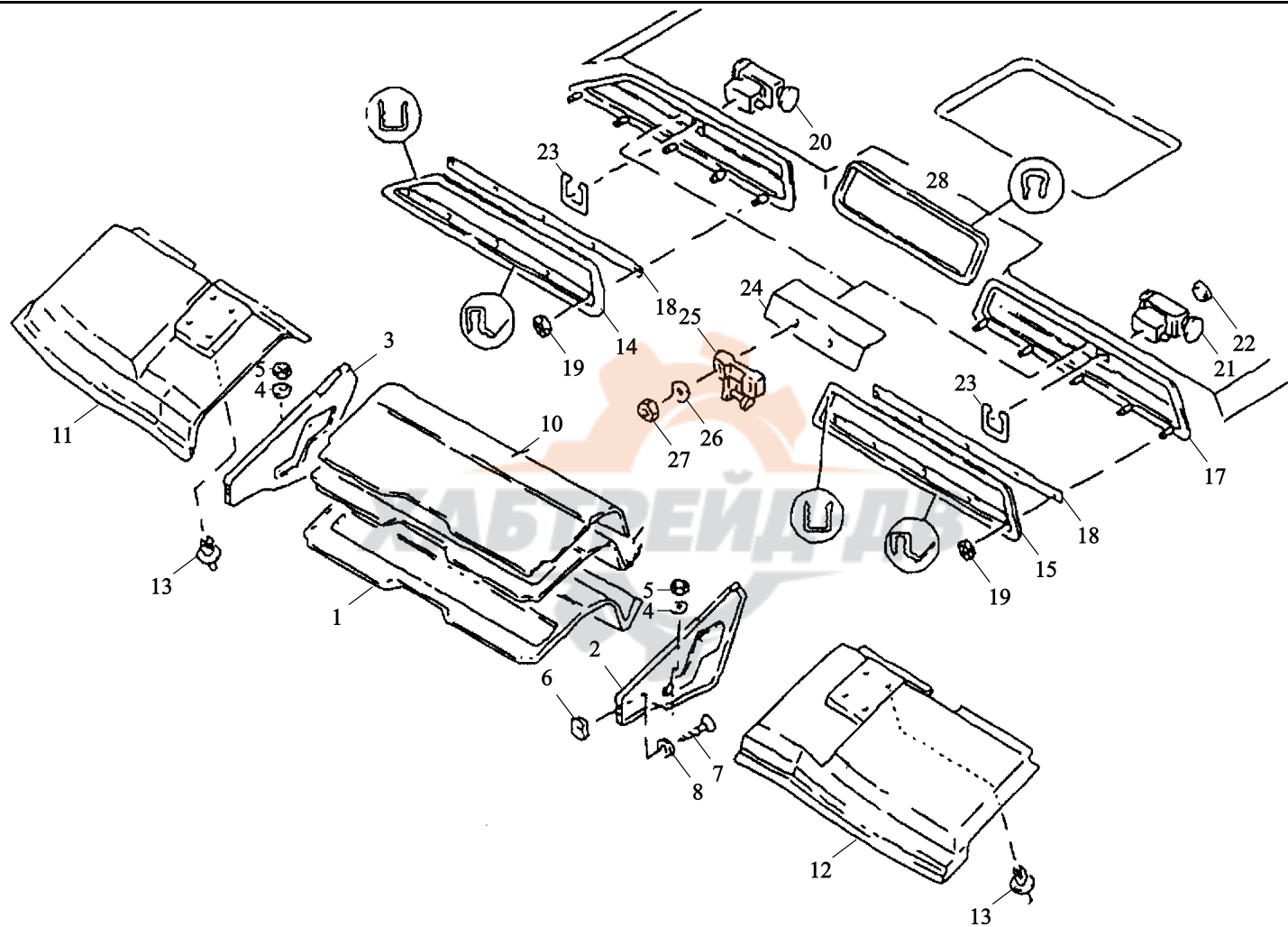



17	81.63903.5043	左盖总成	Cover assembly left	1		
18	81.63903.0025	有孔嵌条	Hole washer	2		398×13×0.75
19	06.13189.0009	锁紧垫圈	Lock washer	10		4-9.6-C67-A2C
20	81.97100.6100	锁总成	Lock assembly	1		
21	81.61444.0013	转动锁总成	Turn lock assembly	1		
22	81.97104.0012	盖	Cover	1		
23	81.61440.0016	塑料夹箍	Clamp plastic	2		
24	81.62940.0040	支 架	Bracket	2		
25	81.63903.0144	锁 板	Lock plate	2		
26	06.15191.0207	垫 圈	Washer	4		6.4×18×1.6-140HV-MAN183-B1
27	06.11069.0106	六角螺母	Hexagon nut	4		M6-8-MAN183-B1
28	81.63903.0152	中间密封架	Sealing frame center	1		

遮阳板 SUN VISOR

遮阳板

序号
NO

注  
mark

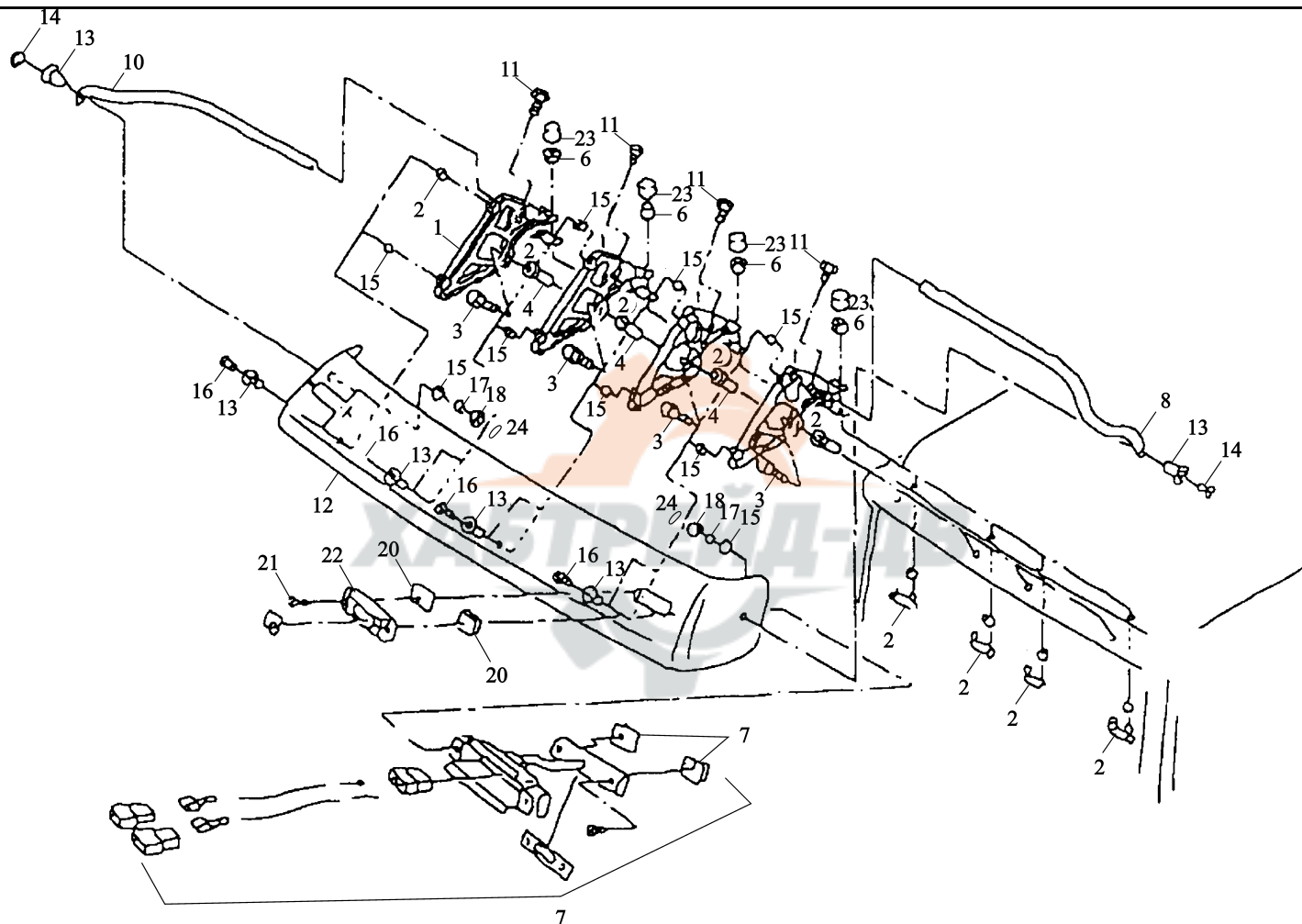

	81.63701.0011	宽遮阳板	Conversion set sun visor	1		用于半高顶
	DZ16.4387.0010	宽遮阳板	wide man logo Conversion set sun visor	1		用于半高顶 高顶
1	81.63735.0024	装配支架	wide man logo Mounting bracket	4		
2	81.63735.0025	装配支架	Mounting bracket	4		用于半高顶 高顶
3	81.63735.5005	搭接板总成	Fish plate assembly	4		
4	81.63735.5005	螺 栓	Hex bolt	4		M8×35Z1-8.8-MAN183-A2C
4	06.01470.0516	空心铆接螺母	Blind rivet nut	4		AM5×15.2-CR60/CUZN
5	06.13169.0007	密封垫	Packing	4		
6	81.63735.0018	锁紧螺母	Hex collar lock nut	8		M8SC-8-A3C
7	06.11229.0003	橡胶过渡组件(带线束)		2		
8	81.63701.6023		Speed nut	4		ST4.2-2-A3C
9	06.13189.0012	簧片螺母	Support tube left	1		
	81.63701.0015	左支架管	Support tube left	1		用于半高顶 高顶
10	81.63701.0023	左支架管	Support tube right	1		
	81.63701.0016	右支架管	Support tube right	1		用于半高顶 高顶
11	81.63701.0022	右支架管	Grooved oval head screw	4		PT-KA6×50-WN1442-ST-A3B
12	81.90470.0607	带槽的椭圆头螺钉	Sun visor wide	1		
	81.63701.0011	宽遮阳板	Sun visor wide	1		用于半高顶 高顶
13	81.63701.0021	宽遮阳板	Spacer bush	10		
14	81.96210.0509	隔 套	Oval-head countersunk screw	2		
15	06.04201.8611	盘头螺钉	Seal asbestos-free	10		
16	81.96601.0456	非石棉密封件	Grooved raised head coll.	8		PT-K6×30-WN1451-ST-T25-
	81.90470.0626	带内扭矩的螺钉	screw with internal torx			A3L

遮阳板 SUN VISOR

遮阳板

序号
NO

注  
mark

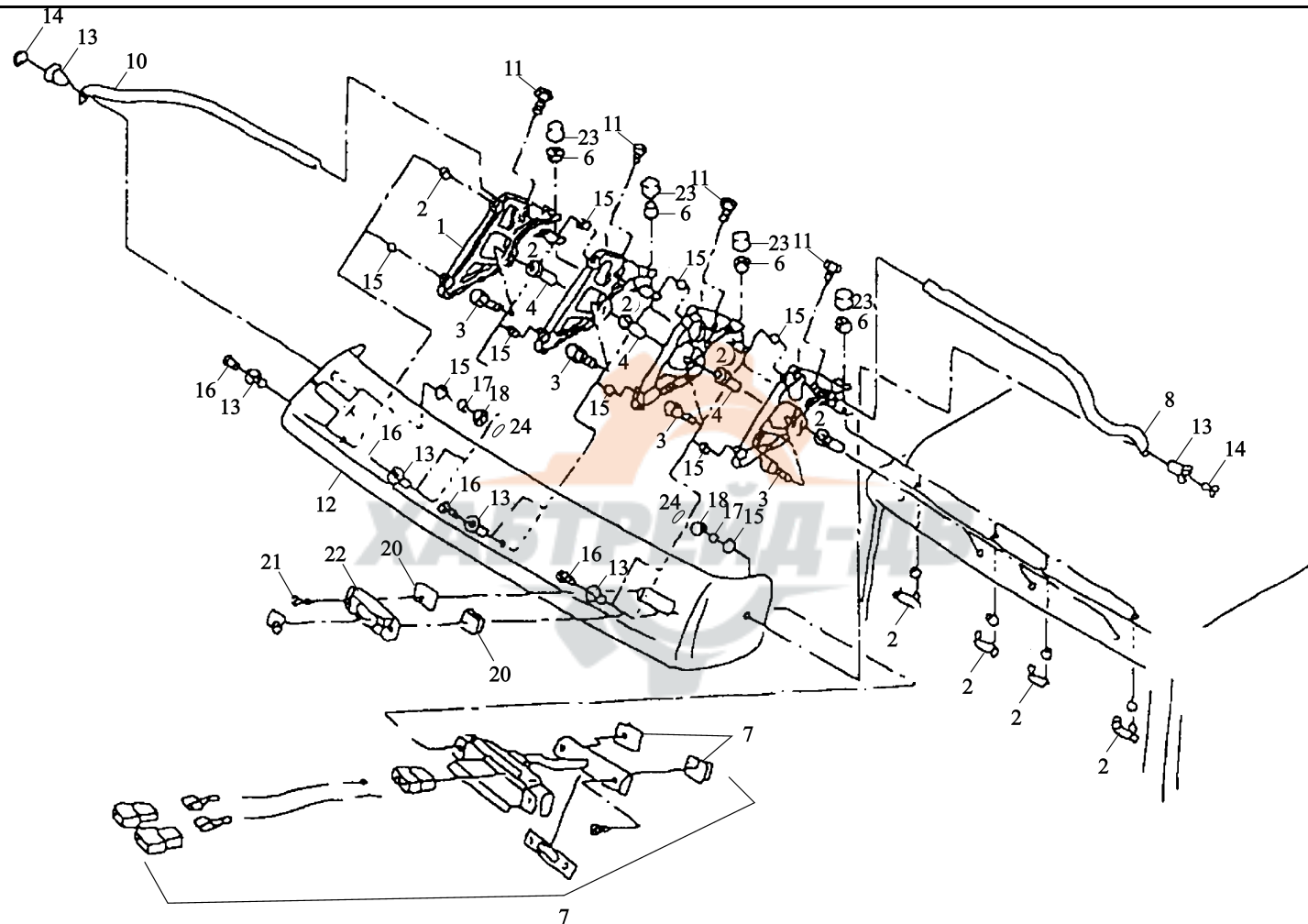

17	06.15191.0207	垫 圈	Washer	2		6.4×18×1.6-140HV-MAN183-B1
18	06.11184.0112	锁紧螺母	Hex lock nut	2		AM6-8-MAN183-B1
19	81.63701.0013	示高灯塑料座	Adapter	2		
20	06.13189.0071	簧片螺母	Speed nut	4		ST4.2-7-A3C
21	06.13189.0012	簧片螺母	Speed nut	4		ST4.2-2-A3C
22	06.07175.1506	自攻螺钉	Self-tapping oval head	4		ST4.2×22C-H-A3R
23	81.96410.0503	盖	screw	12		
24	82.96002.0017	帽	Cap Cap	2		



可加□的右可□□

### LOWER VIEW MIRROR RIGHT HEATABLE

可加□

序号
NO

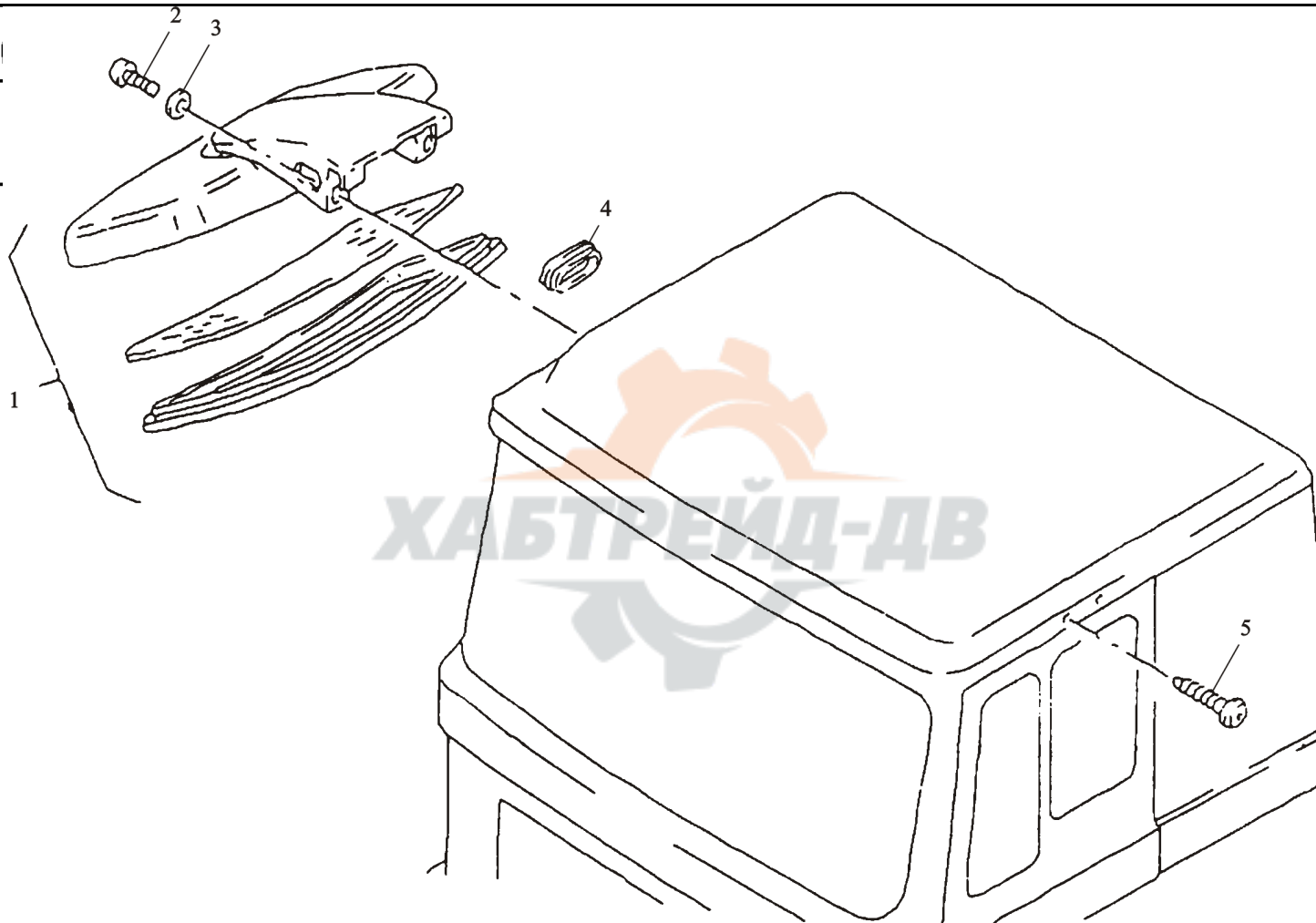

注  
ark

1	81.63730.6294	下视镜总成	Lower view mirror electric heatable adjustable	1		带加热
	DZ16.4277.002 0	下视镜总成	Lower view mirror electric heatable adjustable	1		不带加热
2		盘头螺钉	Pan-head screw	2		M6×16SC-4.8-H-A2R
3	06.04201.8657	平垫圈	Washer	2		A6.4×12×1.6-200HV-A3C
4	06.15013.6109	无孔胶圈	Grommet without hole	2		
5	81.96001.0461 81.96002.0409	螺 塞	Plug	4		A5.3×20-14-POM-SW



加 □ 可 □ 后 □ □

### REAR VIEW MIRROR HEATABLE AND ADJUSTABLE

加 □  
序号  
NO

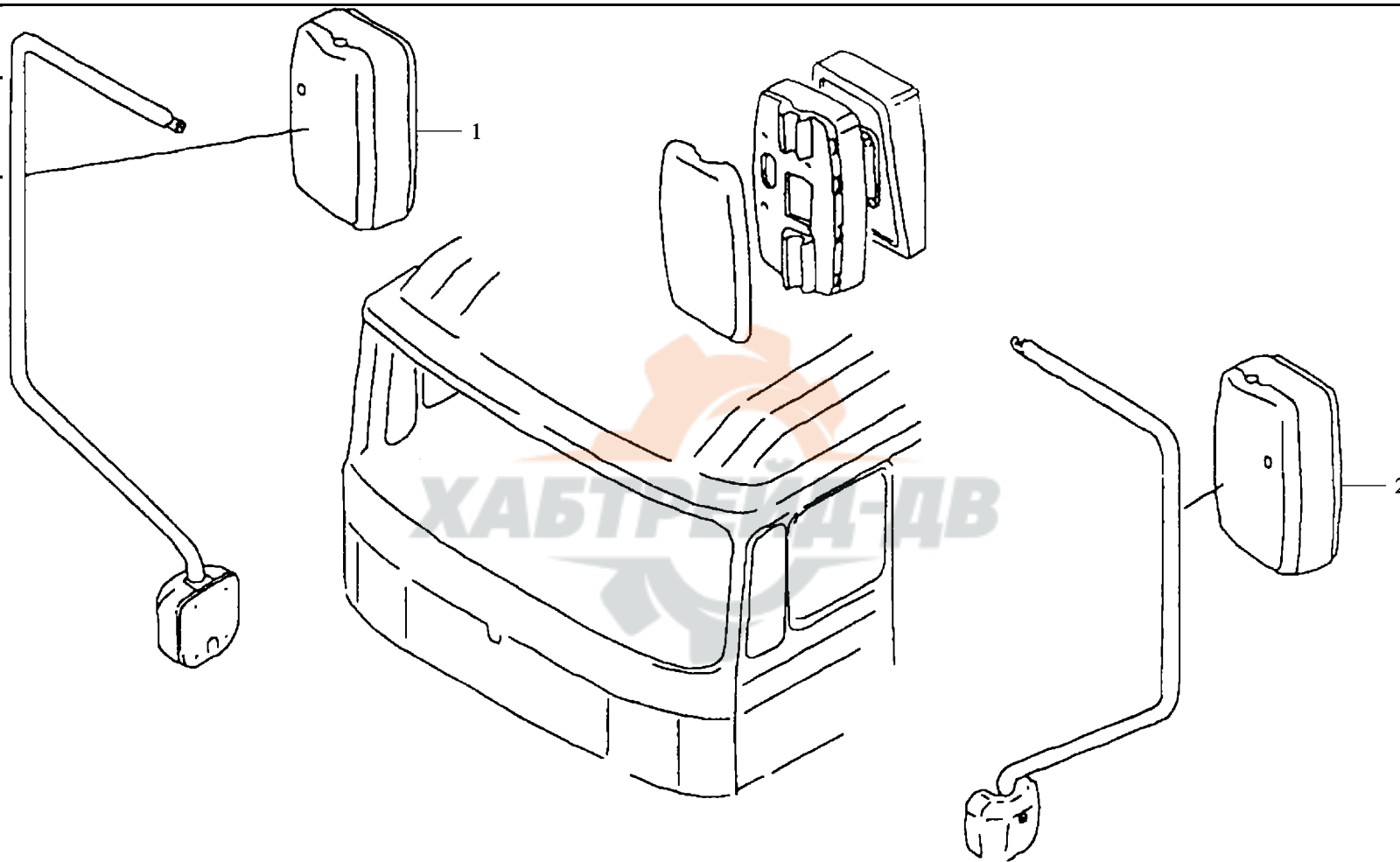



1	81.63730.6368	右电动加热可调后视镜	Rear view mirror electric heatable adjustable right	1		
2	DZ1642770032	右侧后视镜	Side right rear view mirror	1		
	81.63730.6365	左电动加热可调后视镜	Rear view mirror electric heatable adjustable left	1		
	DZ1642770031	左侧后视镜	Side left rear view mirror	1		不加热 Without heater



右加 □ 可 如 □ 后 □ □

### WIDE-VIEW MIRROR HEATABLE RIGHT

右加 □ 画

序号	
NO	

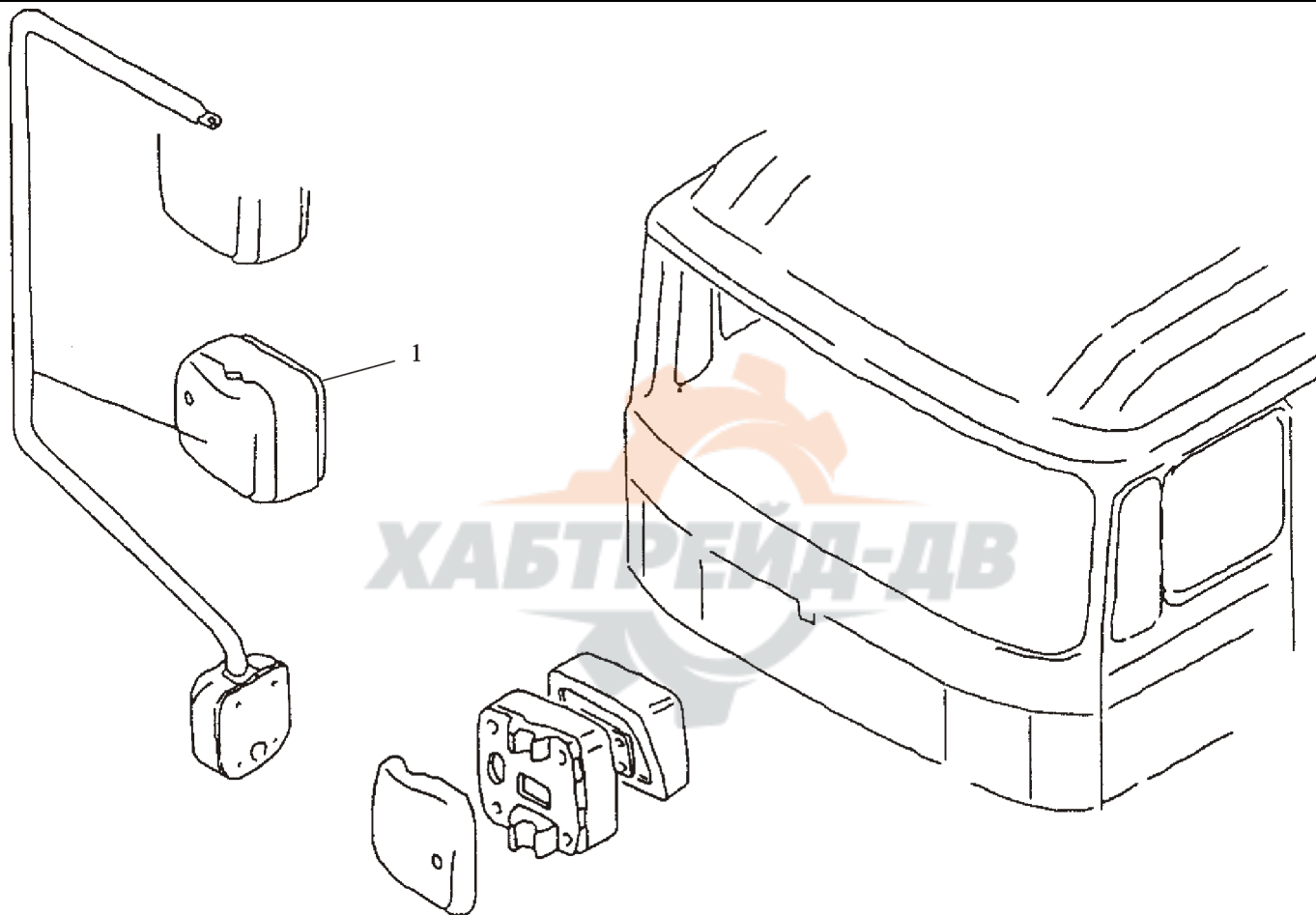

注  
mark

1	81.63730.6307	电动可调加热后视镜	Wide-view mirror heatable elec.adjustable	1		
	DZ16.4277.003 3	宽视野后视镜	Wide-view rear mirror	1		不加热 Without heater



后 □ □ 左 支 架      MIRROR BRACKET LEFT FOR REAR VIEW MIRROR

后  
序

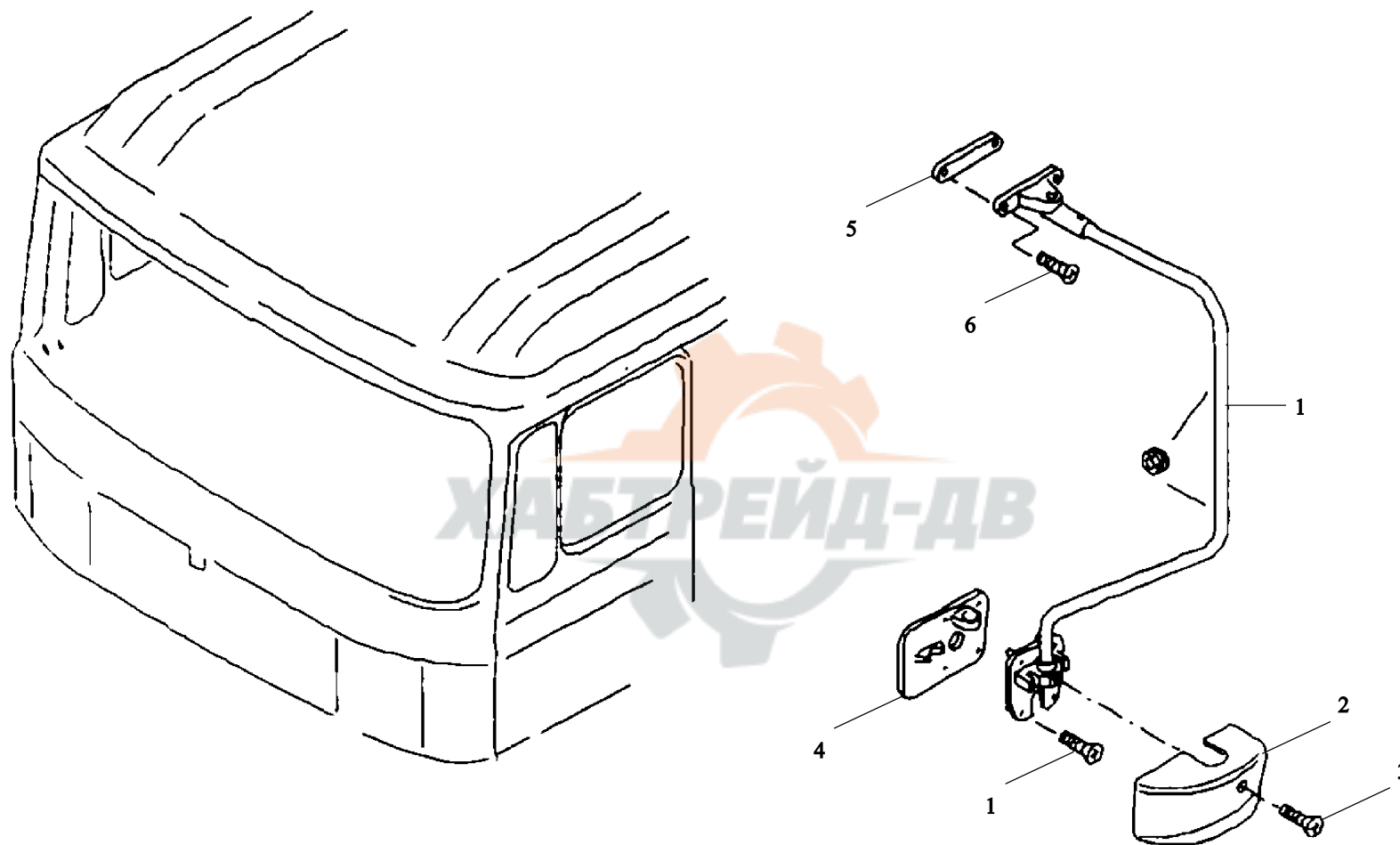

1	81.63731.6489	左视镜支架总成	Mirror bracket assembly left	1		
	DZ16.4277.003	左视镜支架总成	Mirror bracket assembly left	1		
2	0	左 盖	Cap left	1		不加热 Without heater
3	85.63710.0009	盘头螺钉	Pan-head screw	1		
4	06.04209.0022	左支架	Packig left lower	1		M5×12SC-4.8-H-A2R
5	81.63731.0239	衬 垫	Packing mirror	1		
6	81.63731.0184	圆头螺钉	Oval-head countersunk screw	6		
	06.04309.0007					M6×20SC-8.8-H-MAN183-B4



后 □ □ 右 支 架      MIRROR BRACKET RIGHT FOR REAR VIEW MIRROR

后 □ □ 右 支 架

序 号	件 号
NO	Part.N

备 注
Remark

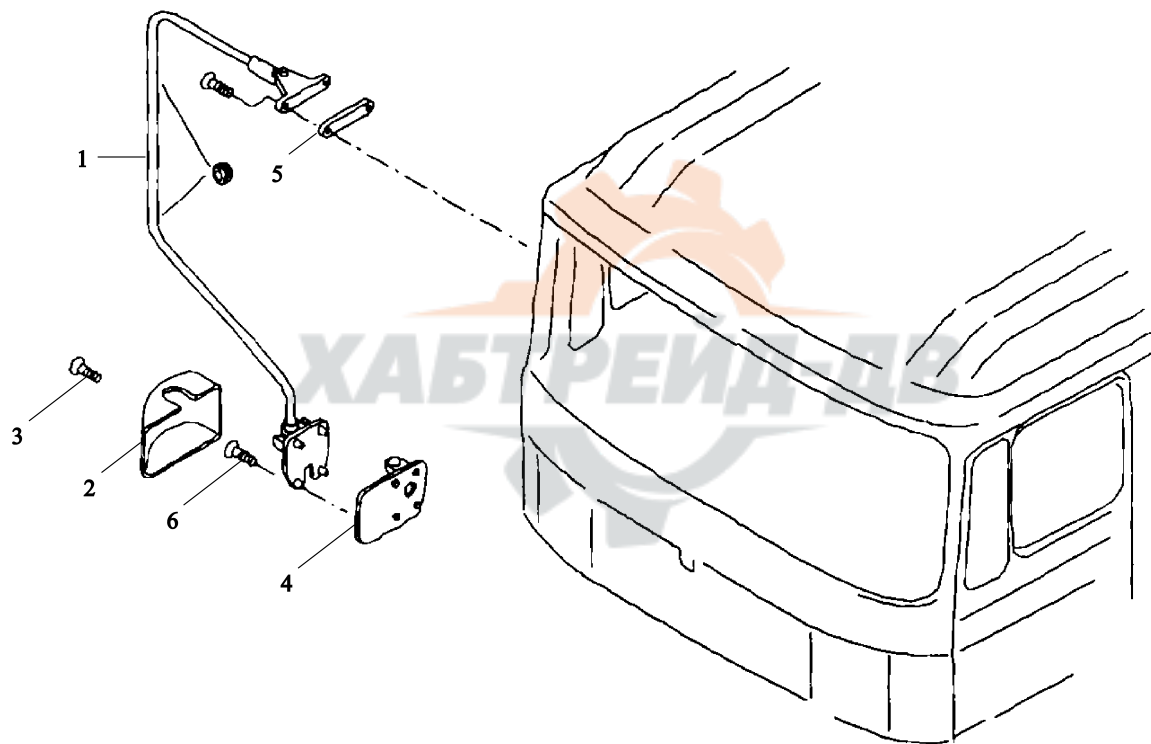

1	81.63731.6490	右视镜支架总成	Mirror bracket assembly right	1		
	DZ16.4277.004	右视镜支架总成	Mirror bracket assembly	1		不加热 Without heater
2	0	右盖	Cap right	1		
3	85.63710.0010	盘头螺钉	Pan-head screw	1		M5×12SC-4.8-H-A2R
4	06.04209.0022	右支架	Packing right lower	1		
5	81.63731.0238	衬垫	Packing mirror	6		
6	81.63731.0184	圆头螺钉	Oval-head countersunk screw			M6×20SC-8.8-H-MAN183-B4
	06.04309.0007					



加强件 □ □ REINFORCEMENT HINGE

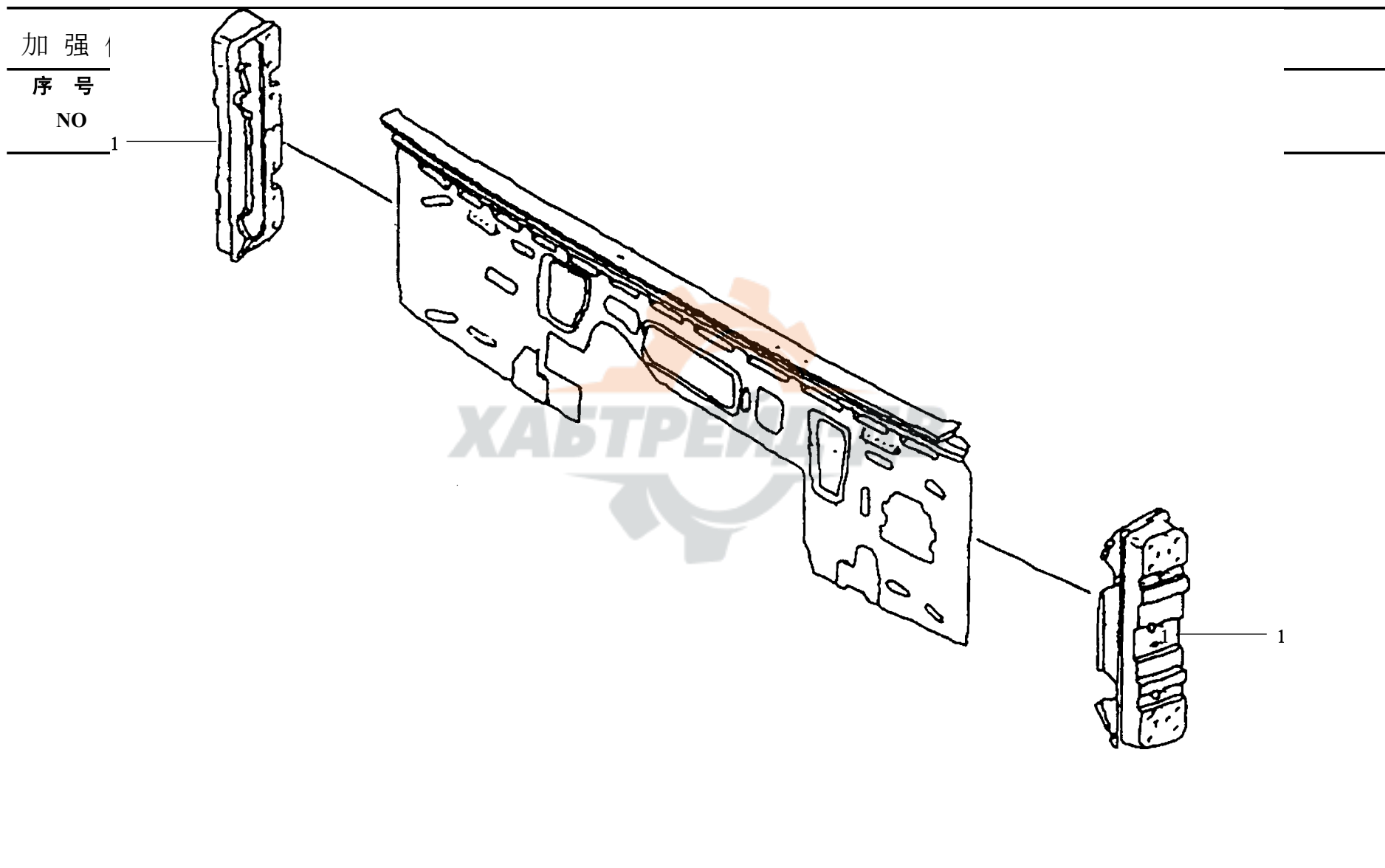



1	81.62410.4286	前围下支柱总成	Reinforcement hinge	2		焊于驾驶室本体 Welding to cab
---	---------------	---------	---------------------	---	--	---------------------------



前 板 修 理 板      FRONT PANEL REPAIR PANELS 3-PART

前 板 修 理 板

序 号	件 号
NO	Part.No

备 注
Remark

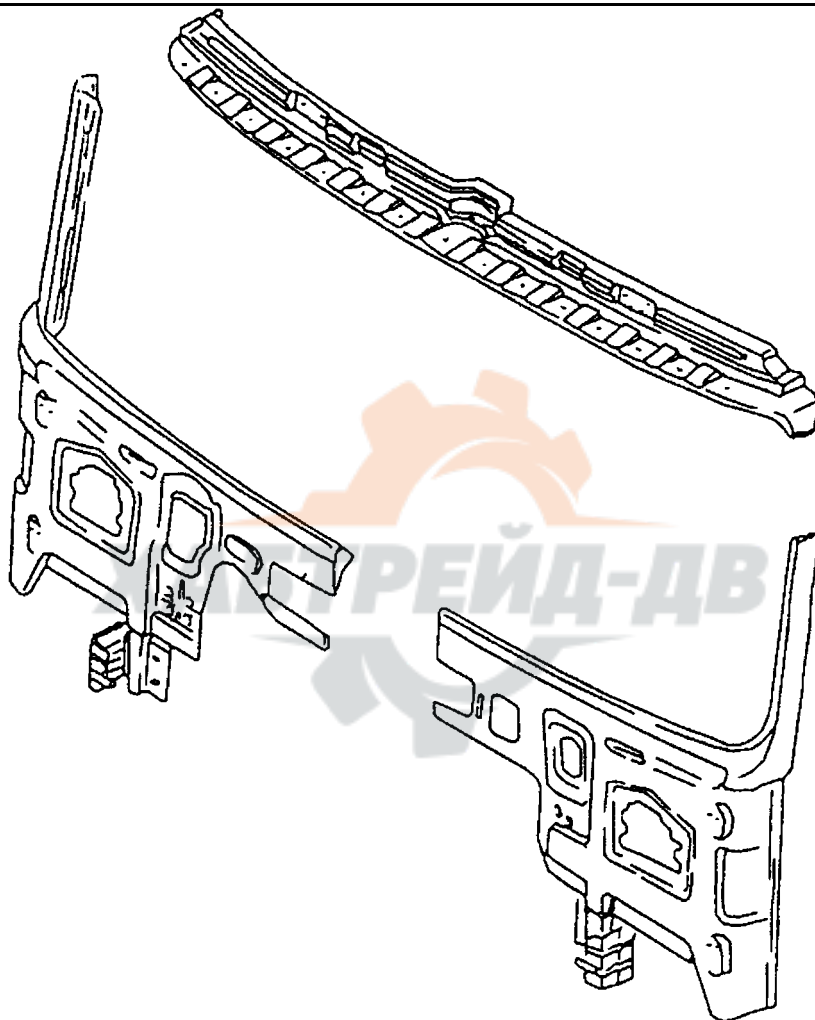

81.62410.4301	前围外板分总成	Front panel assy	1		焊于驾驶室本体
---------------	---------	------------------	---	--	---------



□ 表板前 □ 板 FRONT PANEL WITH DASHBOARD

□ 表板前

序号	1
NO	1

备注  
remark

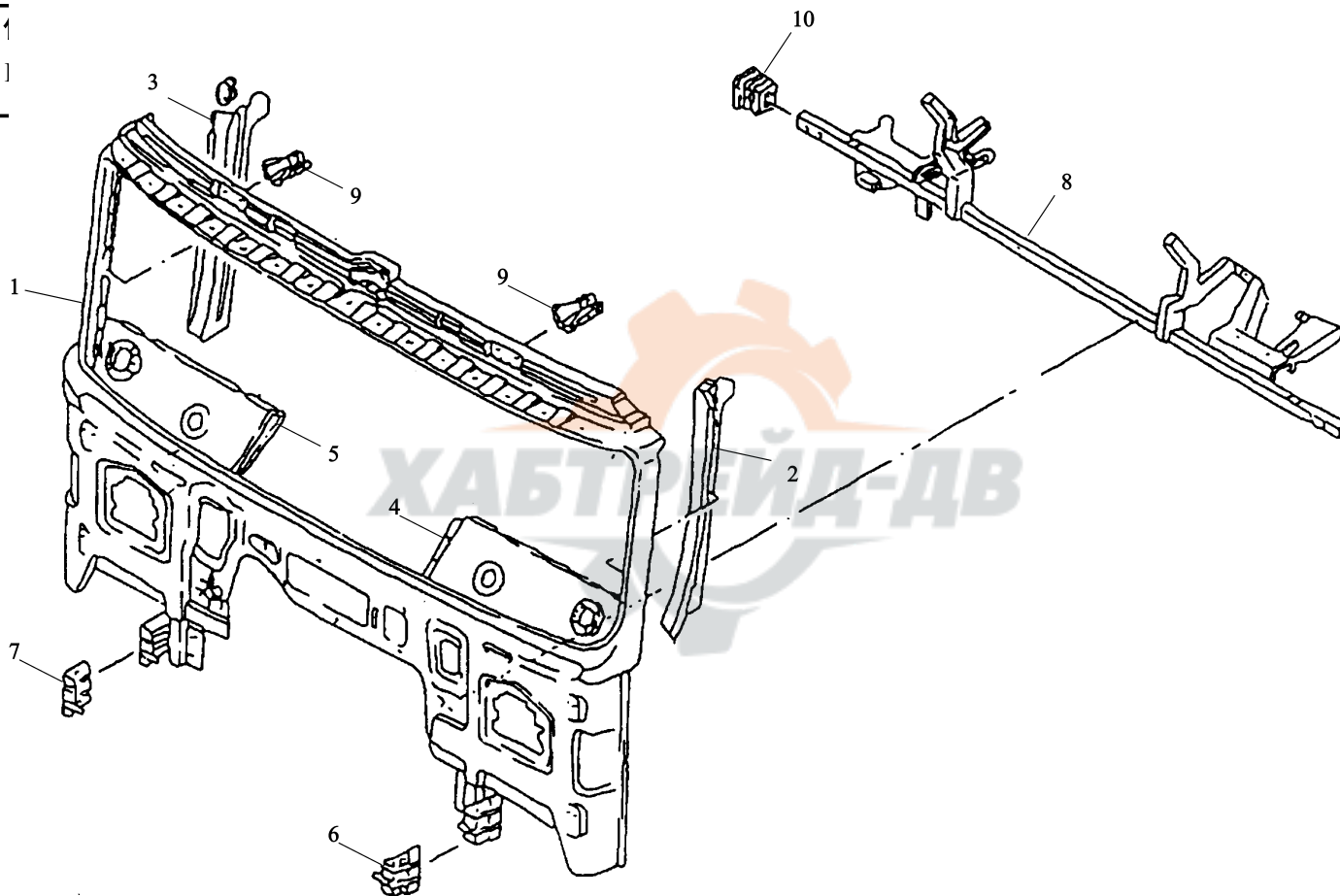

1	81.62410.4303	前围外板分总成	front panel replacement	1		
2	81.61430.4373	前围左上内立柱总成	front panel assembly left upper	1		
3	81.61430.4374	前围右上内立柱总成	front panel assembly right upper	1		
4	81.61430.4421	仪表板左支撑板总成	covering assembly left	1		
5	81.61430.4420	仪表板右支撑板总成	covering assembly right	1		
6	81.42440.4009	左支架总成	bracket assembly left	1		
7	81.62440.4010	右支架总成	bracket assembly right	1		
8	81.61420.4087	仪表板支架总成	tool support replacement group	1		
9	81.62910.2460	前连接纵梁	bracket	2		
10	81.96002.0389	塑料堵	plug	2		C45×33×2-M3165E1-NF

支架 BRACKET

支  
序

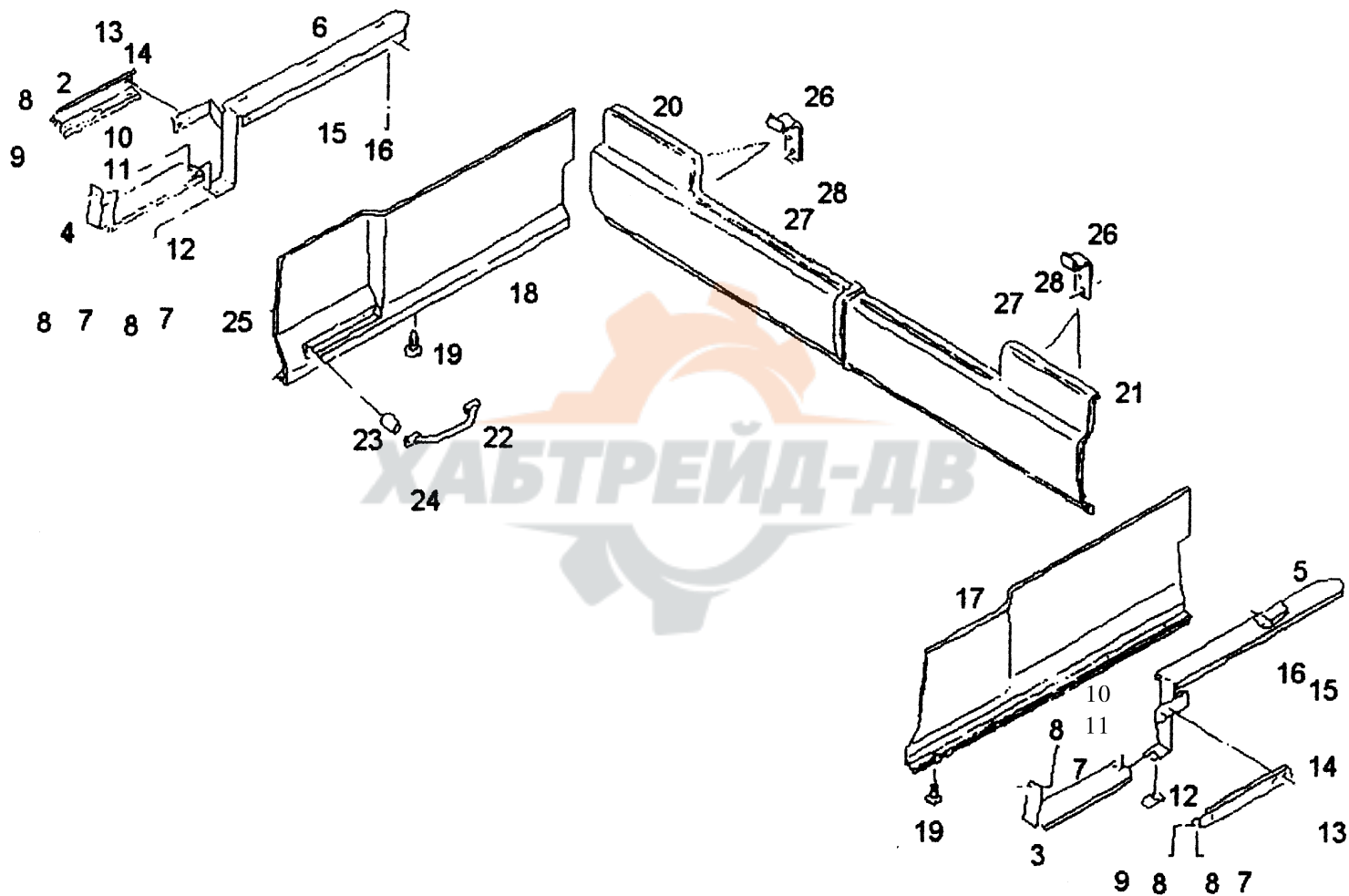

1	81.62930.0047	左前支架	Carrier left front	1	
2	81.62930.0046	右前支架	Carrier right front	1	
3	81.62930.0049	U型左支架	U channel left	1	
4	81.62930.0048	U型右支架	U channel right	1	
5	81.62930.5107	左后支架	Carrier assembly left	1	
6	81.62930.5106	右后支架	Carrier assembly right	1	
7	06.04201.4511	盘头螺钉	Pan-head screw	8	M5×25-4.8-H-A2C
7	06.04201.4511	盘头螺钉	Pan-head screw	4	M5×25-4.8-H-A2C
7	06.07158.1604	自攻螺钉	Oval-head self-tapping screw	4	ST4.8×16C-H-A3R
8	06.15013.0408	垫圈	Washer	12	A53×10×1-200HV-MAN183-B1
9	06.11064.2111	螺母	Hexagon nut	4	M5-8-MAN183-B1
10	06.07158.1604	自攻螺钉	Oval-head self-tapping screw	4	ST4.8×16C-H-A3R
11	06.15013.0408	垫圈	Washer	4	A53×10×1-200HV-MAN183-B1
12	06.13189.0025	螺母	Speed nut	4	ST4.8-1-A3C
13	06.11064.2112	螺母	Hexagon nut	4	M6-8-MAN183-B1
14	06.15013.0409	垫圈	Washer	4	A64×12×1.6-200HV-MAN183-B1
15	06.07158.1604	自攻螺钉	Oval-head self-tapping screw	10	ST4.8×16C-H-A3R
16	06.15190.0306	垫圈	Washer	10	53×15×12-140HV-MAN183-B1
17	81.62930.6033	侧围左上衬	Panelling	1	
18	81.62930.6032	侧围右上衬	Panelling	1	
19	06.24249.0007	销钉	Rivet	10	7×3×17.5-4-PA6.6-SW
20	81.62930.5146	后围右上衬总成	Panelling assembly	1	
21	81.62930.5145	后围左上衬总成	Panelling	1	
22	81.97001.6069	扶手总成	Grab handle assembly	1	
23	81.33110.2003	衬套	bush	4	6×10×8-ST50-2

支架 BRACKET

支  
序

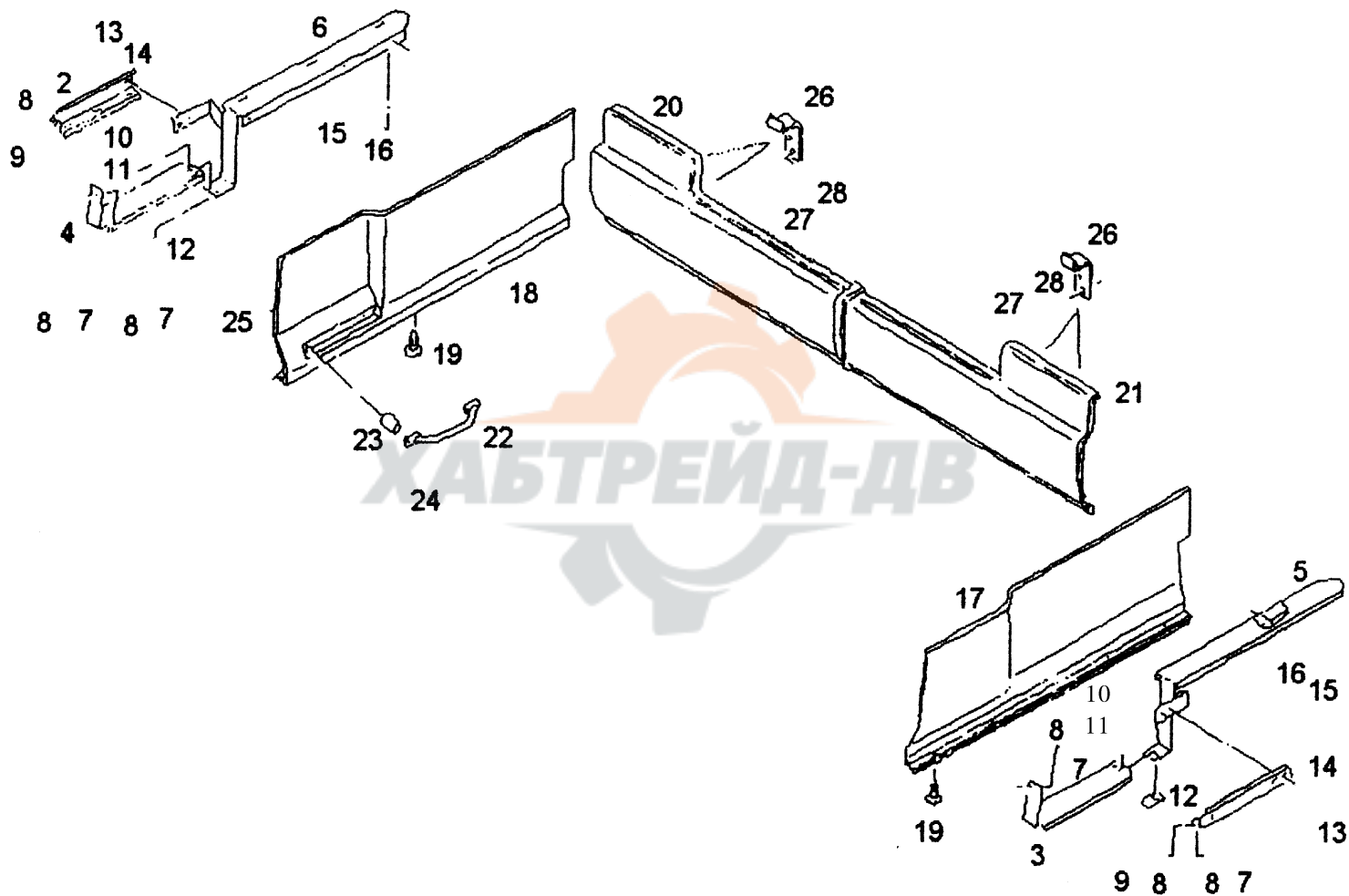





24	06.07159.0012	盘头螺钉	Oval-head self-tapping screw	4		ST4.8×22C-H-MAN183-B1
25	06.13189.0025	螺 母	Speed nut	4		ST4.8-1-A3C
26	81.97487.0851	角 架	Angle	4		
27	06.07158.1604	自攻螺钉	Oval-head self-tapping screw	8		ST4.8×16C-H-A3R
28	06.15013.0408	垫 圈	Washer	8		A5.3×10×1-200HV-MAN183-B1
	81.63703.6035	高顶左小窗遮阳帘	High roof sun visor shade left			
	81.63703.6036	高顶右小窗遮阳帘	High roof sun visor shade right			
	06.07158.1604	自攻螺钉	Oval-head self-tapping screw			4.8×16
	06.13189.0025	簧片螺母	Speed nut			4.8

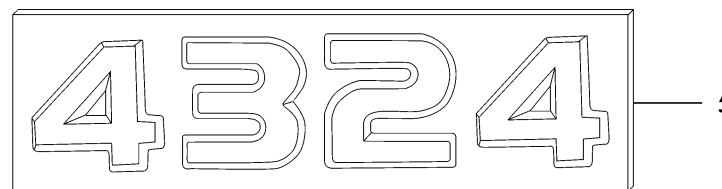
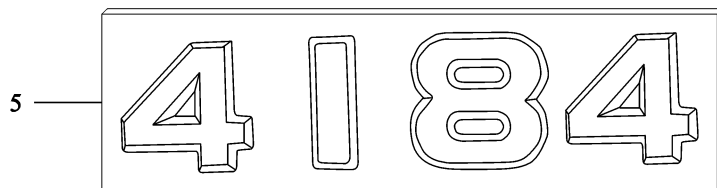
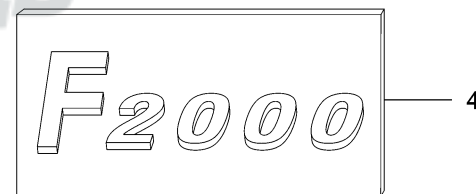
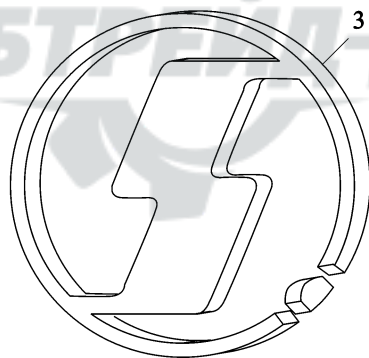
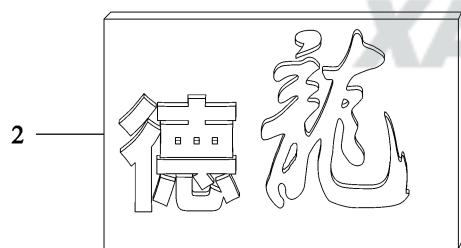
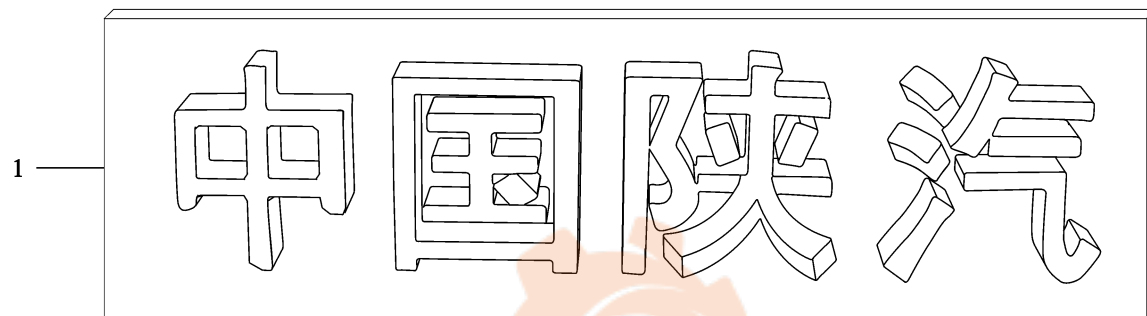

□ 志 牌 TRADE MARK

□ 志  
序 号  
NO



1	DZ16.0093.0002	标志牌“中国陕汽”	Trade mark	1		
2	DZ16.0093.000	标志牌“德龙”	Trade mark	1		
3	5		Trade mark	1		
4	DZ16.0093.000	标志牌“  ”	Trade mark	1		
5	3		Trade mark	1		
	DZ16.4093.000	标志牌“F2000”	Trade mark	1		
	5		Trade mark	1		
	DZ16.0093.325	标志牌“3254”	Trade mark	1		
	4		Trade mark	1		
	DZ16.0093.425	标志牌“4254”	Trade mark	1		
	4		Trade mark	1		
	DZ16.0093.432	标志牌“4322”				
	2					
	DZ16.0093.416	标志牌“4162”				
	2					
	DZ16.0093.419	标志牌“4192”				
	2					
	DZ16.0093.126	标志牌“1264”				
	4					



1	81.66912.0146	右工具箱	Tool box black left right	1	
2	81.66912.0036	工具箱锁支架	Bracket	1	
3	81.97122.0028	下工具箱锁	Lock	1	
4	06.01470.3413	螺 栓	Hex bolt	4	M6×25Z2-SC-8.8-MAN183-A2C
5	06.15013.0409	垫 片	Washer	4	A6.4×12×1.6-200HV- MAN183-B1
6	81.66912.0037	支撑杆支架	Angle	2	
7	81.66912.0059	支撑杆	Support rod	2	
8	81.97640.0210	弹簧夹	Spring clip	2	
9	81.97445.0173	支撑杆固定夹	Line clip	2	
10	06.13189.0108	簧片螺母	Speed nut	12	ST4.8-5-MAN183-B1
11	06.07154.1605	自攻螺钉	Oval-head self-tapping	14	ST4.8×19C-HA3C
12	06.15190.0307	垫 片	screw	14	6.4×18×1.6-140HV-MAN183-B1
13	06.13189.0056	滑动螺母	Washer	4	M6-16×24×4.0-C45-ZN
14	81.97201.0229	铰 链	Slip-on nut	4	
15	06.01470.3413	螺 栓	Hinge	4	M6×25Z2-SC-8.8-MAN183-A2C
16	06.15190.0307	垫 片	Hex bolt	4	6.4×18×1.6-140HV-MAN183.B1
17	81.96410.0564	盖	Washer	4	
18	81.66912.0038	工具箱角支架	Cap	4	
	81.19220.0684	长角铁	Angle	2	
19	06.01470.1510	螺 栓	Lengthend angle	8	M8×18Z2-8.8-MAN183-A2C
20	06.15190.0309	垫 片	Hex bolt	8	8.4×24×2-140HV-MAN183-B1
21	06.11064.2114	螺 母	Washer	4	0M8-8-MAN183-B1
22	81.95501.6372	工具箱锁拉线总成	Hexagon nut Bowden cable assembly	2	

工具箱 TOOL BOX

工具  
序号  
NO

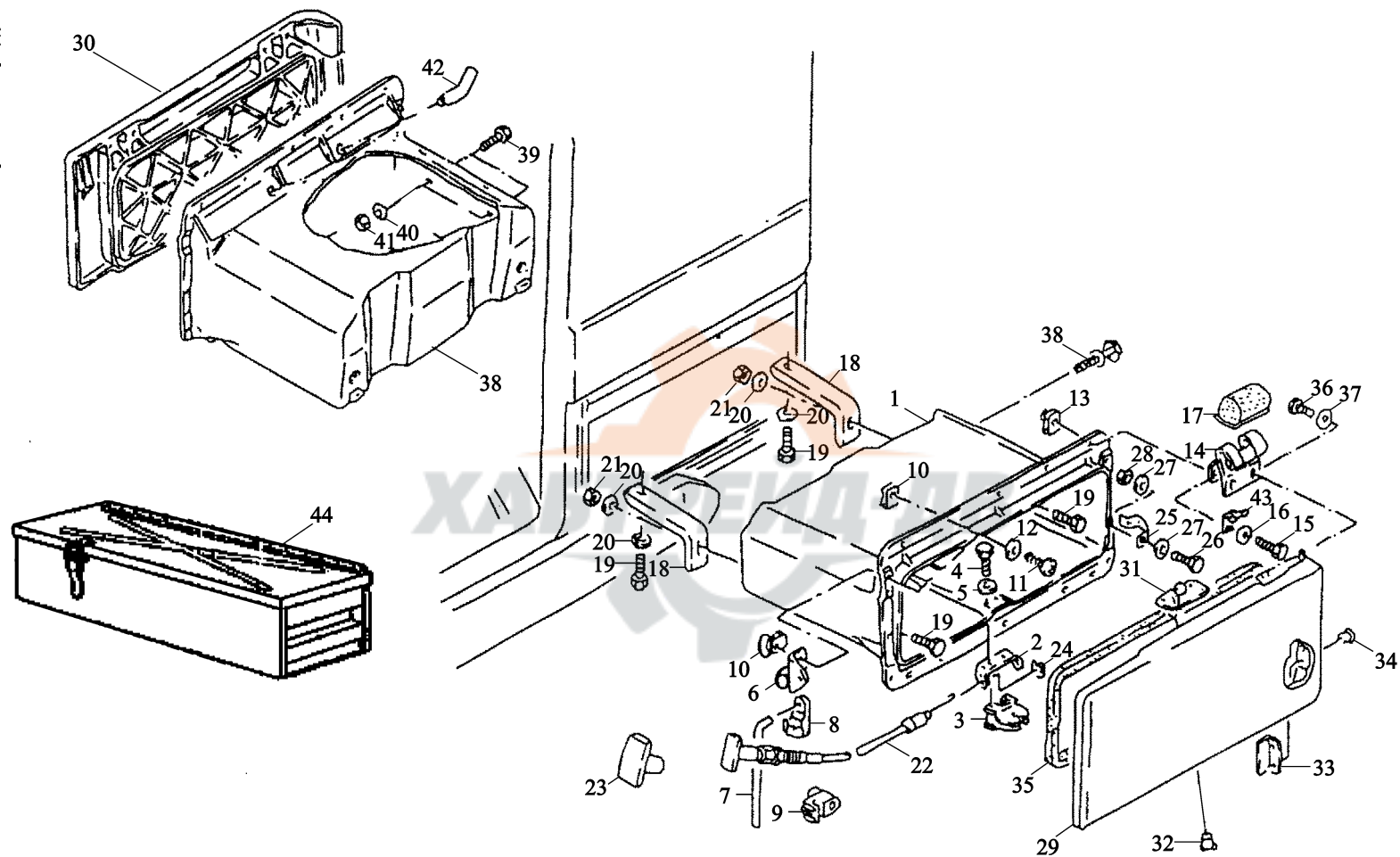

23	81.97001.0518	拉 手	Handle	1	
24	06.29050.0109	锁紧垫片	Lock washer	2	
25	81.97651.0111	限位簧片	Spring	2	
26	06.01283.4911	螺 栓	Hex bolt	2	M6×16-8.8-MAN183-B1
27	06.15190.0307	垫 片	Washer	2	6.4×18×1.6-140HV-MAN183-B1
28	06.11064.2112	螺 母	Hex agon nut	2	M6-8-MAN183-B1
29	81.66912.0033	左工具箱盖	Flap tool box left	1	
30	81.66912.0034	右工具箱盖	Flap tool box right	1	
31	81.66912.2543	锁止销	Striker plate	2	
32	06.24249.0074	空心铆钉	Blind rivet	8	4.8×7.5-9
33	81.97488.2075	2 孔角铁	Angle 2 holes	2	
34	06.24249.0073	空心铆钉	Blind rivet	4	4.8×5-6.5
35	81.96601.2023	非石棉衬垫	Gasket asbestos-free	2	
36	06.01283.4909	螺 栓	Hex bolt	8	M6×10-8.8-MAN183.B1
37	06.15191.0207	垫 片	Washer	8	6.4×18×1.6-140HV-MAN183-B1
38	81.66912.0145	左工具箱	Left tool box	1	
39	06.01470.0409	螺 栓	Hex bolt	4	M6×16-8.8-MAN183-B1
40	06.15191.0207	垫 片	Washer	4	A6.4×12×1.6-200HV- MAN183-B1
41	06.11184.0112	螺 母	Hexagon nut	4	M6-8-MAN183-B1
42	81.96001.0416	通气胶圈	Grommet	4	
43	81.97201.0252	挡 块	Stop	4	

□ 支座的千斤□ 吨架 JACK HOLDER WITH MOUNTING

□ 支座

序号
NO

注  
ark

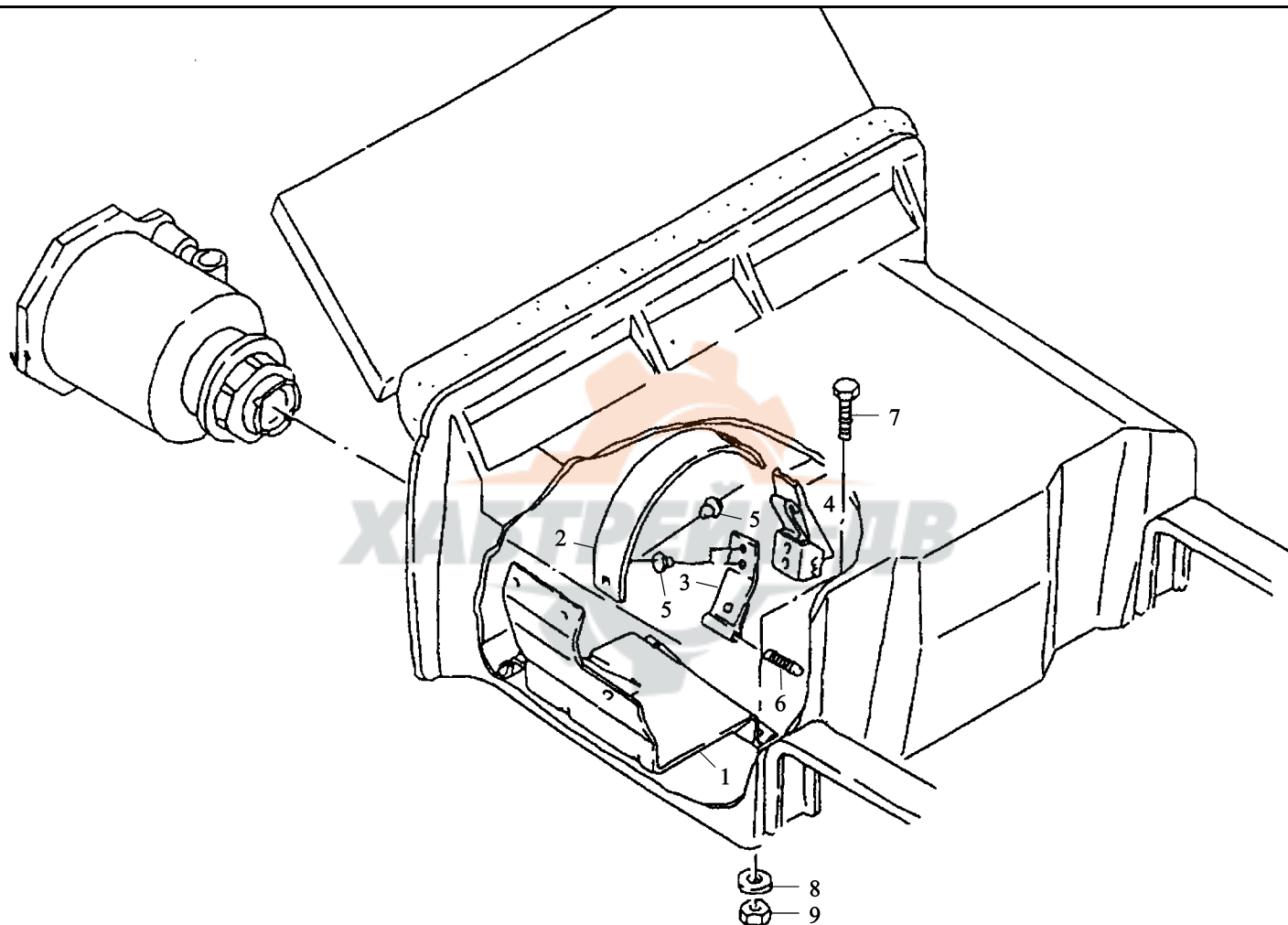



	81.66937.6017	千斤顶支架总成	Jack holder bracket assy	1		装车用号包含 1-6
1	81.66937.2023	支 架	Bracket	1		
2	81.66937.2024	嵌 条	Strap	1		
3	81.66937.2025	嵌 条	Strap	1		
4	81.97106.0005	夹 锁	Clamp lock	1		
5	06.24249.0060	空心铆钉	Blind rivet	5		A4×7.5-A2/A2-BK/BK
6	06.22229.0005	螺旋定位销	Spiral dowel	1		6×50-X12CRNI177
7	06.01470.0409	六角螺栓	Hex bolt	4		M6×16Z2-8.8-MAN183C-A2C
8	06.15191.0207	垫 圈	Washer	4		6.4×18×1.6-140HV-MAN183-B1
9	06.11184.0112	六角螺母	Hexagon nut	4		M6-8



随 □ 工 具 ( 一 )      ATTACHED TOOLS I

随 □ 工
序 号
NO

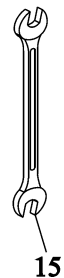
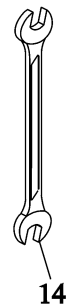
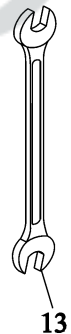
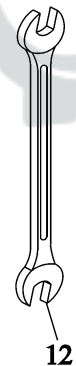
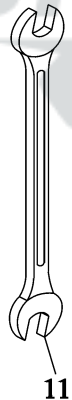
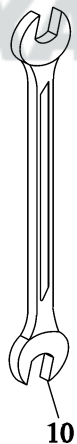
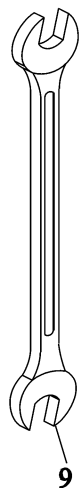
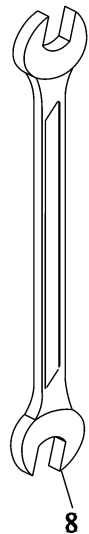
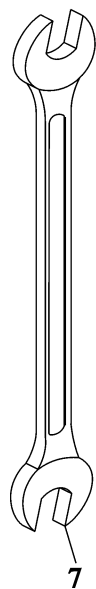
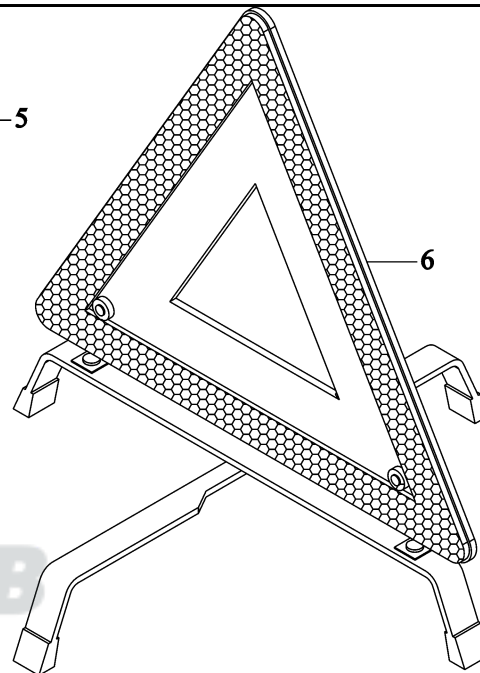
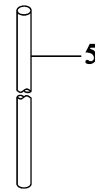
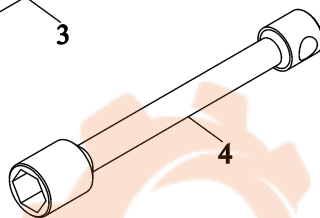
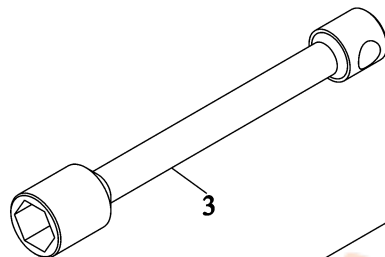
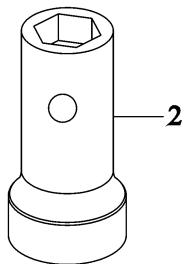
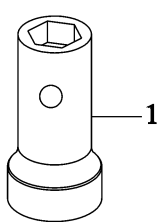

1	99100850002	螺母套筒	Screw socket	1	GB3077
2	AZ9100850011	螺母套筒	Screw socket	1	GB699
3	AZ9100850014	双□ 梅花套筒扳手	Double clubs socket spaner	1	GB699
4	AZ9100850026	双□ 梅花套筒扳手	Double clubs socket spaner	1	GB699
5	AZ9100850004	套筒扳手	Socket spaner	1	GB8162
6	DZ9100850030	三角警告牌	Triangle indication brand	1	
7	AZ9003580028	两用扳手 24×24	Spaner	1	GB4393
8	AZ9003580027	两用扳手 24×24	Spaner	1	GB4393
9	AZ9003580026	两用扳手 22×22	Spaner	1	GB4393
10	AZ9003580025	两用扳手 22×22	Spaner	1	GB4393
11	AZ9003580024	两用扳手 21×21	Spaner	1	GB4393
12	AZ9003580023	两用扳手 21×21	Spaner	1	GB4393
13	AZ9003580022	两用扳手 19×19	Spaner	1	GB4393
14	AZ9003580021	两用扳手 19×19	Spaner	1	GB4393
15	AZ9003580020	两用扳手 18×18	Spaner	1	GB4393
16	AZ9003580019	两用扳手 18×18	Spaner	1	GB4393
17	AZ9003580018	两用扳手 17×17	Spaner	1	GB4393
18	AZ9003580017	两用扳手 17×17	Spaner	1	GB4393
19	AZ9003580016	两用扳手 16×16	Spaner	1	GB4393
		两用扳手 15×15			
		两用扳手 14×14			
		两用扳手 13×13			

随 □ 工 具 □ ( 二 ) ATTACHED TOOLS II

随 □  
序  
N

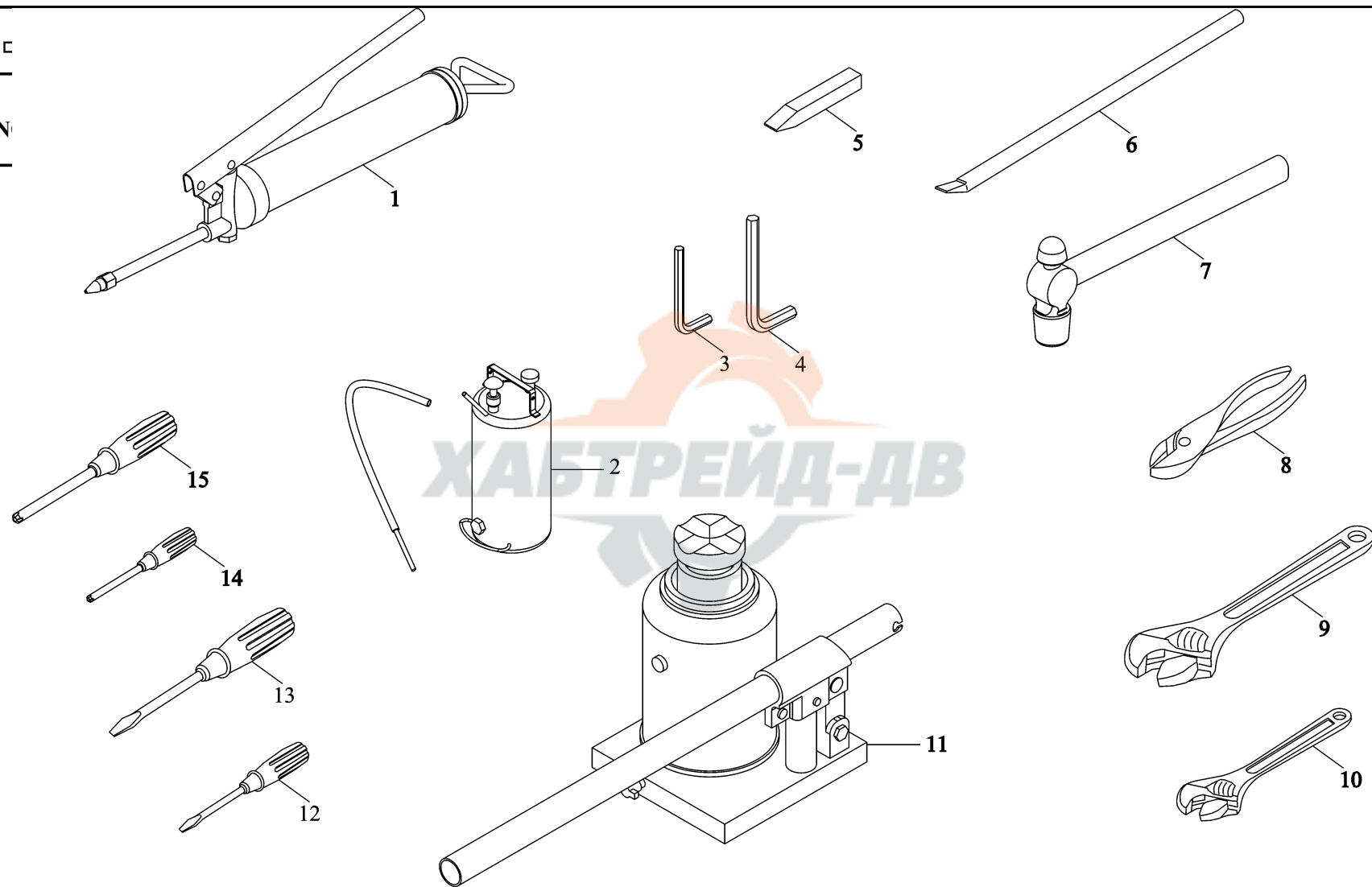

1	AZ9003580014	黄油 200CM×3	Hand oil gun	1	GB1164-89
2	AZ9003580015	□ □ 油加注 □ 100CM×3	Oil gun for gear	1	GB1164-89
3	90003589462		Box spaner	1	GB536
4	90003589475	内六角扳手10	Box spaner	1	GB536
5	AZ9100850006	内六角扳手22	Chisel	1	GB1298
6	AZ9100850055	□ 子 □ T10	Prift	1	( □ 宁 □ □ 斤 )
	AZ9100850056		Prift	1	
	AZ9100850058	“B”型撬杠	Tyre prift	1	( □ 宁 □ □ 斤 )
	AZ9100850059	“A”型撬杠	Tyre prift	1	
7	AZ9100850003	□ 胎撬棒 I	Hammer	1	( 丹 □ 汽 □ 工 具 斤 )
8	AZ9003580013	□ 胎撬棒 II	Combination pliers	1	
9	AZ9003580012	手 □	Screw paner	1	( 丹 □ 汽 □ 工 具 斤 )
10	AZ9003580011	□ □ □ 200	Screw paner	1	
11	99112860003		Jack	1	
12	AZ9003580007	活扳手 300	Screw driver	1	GB4953-85
13	AZ9003580008	活扳手 200	Screw driver	1	
14	AZ9003580009	液 □ 斤 斤 □	Screw driver	1	GB1432-78
15	AZ9003580010	一字螺 □ 刃 YM-III 100×6	Screw driver	1	GB1432-78
		一字螺 □ 刃 YM-III 200×8			GB1433-78 GB1433-78

组合表(框架)总成 COMBINATION GAUGE ASSY WITH FRAME

组合
序号
NO

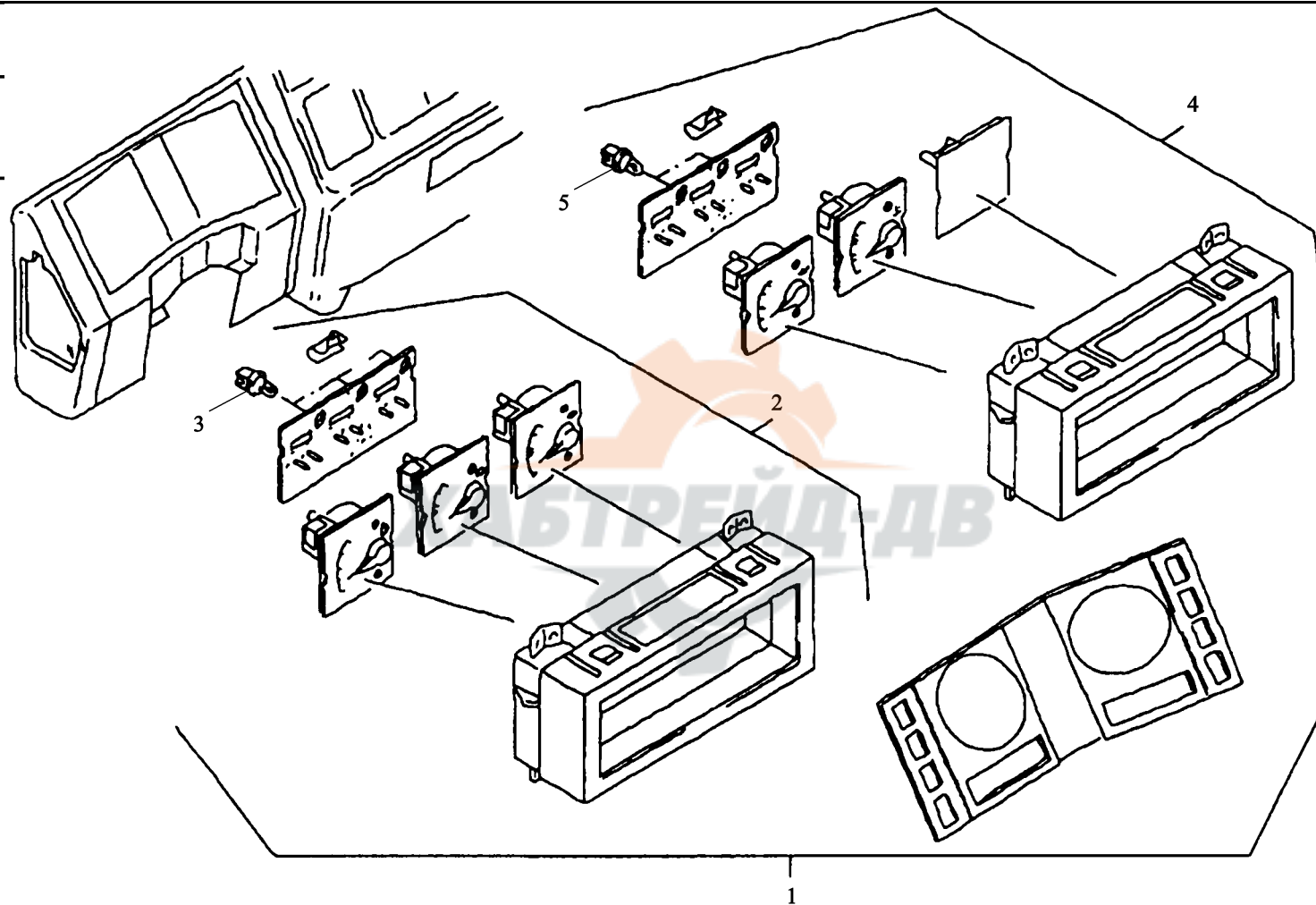

\_\_\_\_\_  
:  
\*k  
\_\_\_\_\_

1	81.27202.6080	组合仪表框架总成	Combination gauge frame assy	1		
2	DZ9100586015	燃油制动气压一、二总成	Fuel 、 brake pressure	1		
3	81.25901.0086	带座灯泡	I、II	3		24V-1.2W-BAX10D
4	DZ9100586016	水温表、机油压力表总成	Bulb with seat	1		
5	81.25901.0086	带座灯泡	Water temperature,oil pressure gauge	2		24V-1.2W-BAX10D
			Bulb with seat			



□ 子 □ 速 里 程 表    ELECTRIC ODOMETER

□ 子  
— 序 号  
— NO  
—

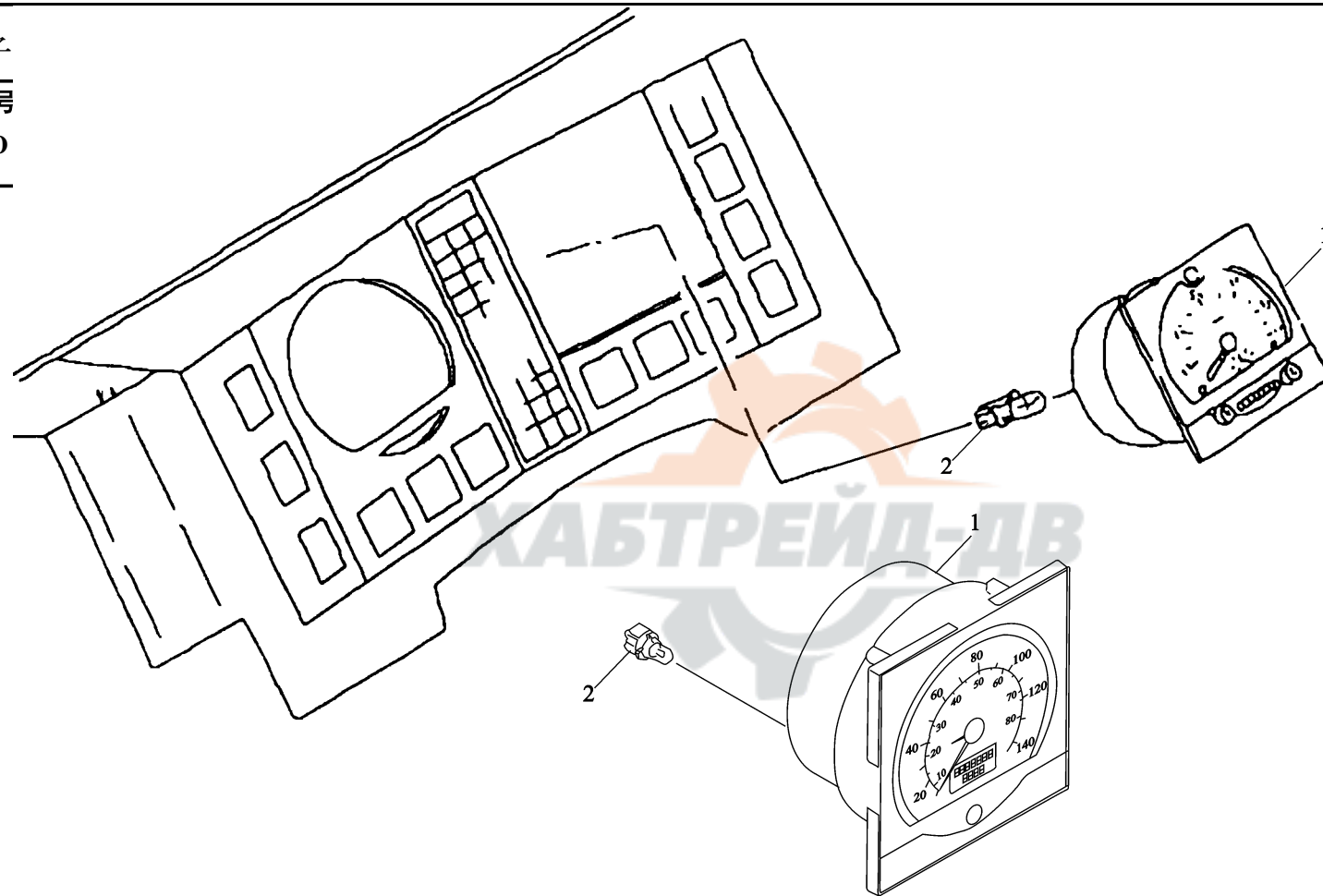



1	81.27110.6048	电子车速里程表	Electronic odometer	1		
	81.27101.6407	电子车速里程表	Electronic odometer	1		
2	81.25901.0086	灯泡 ( 24V 1.2W )	Bulb with holder	1		(选装) for select



# 电子转速表 ELECTRONIC TACHOMETER

电子  
序号  
NO

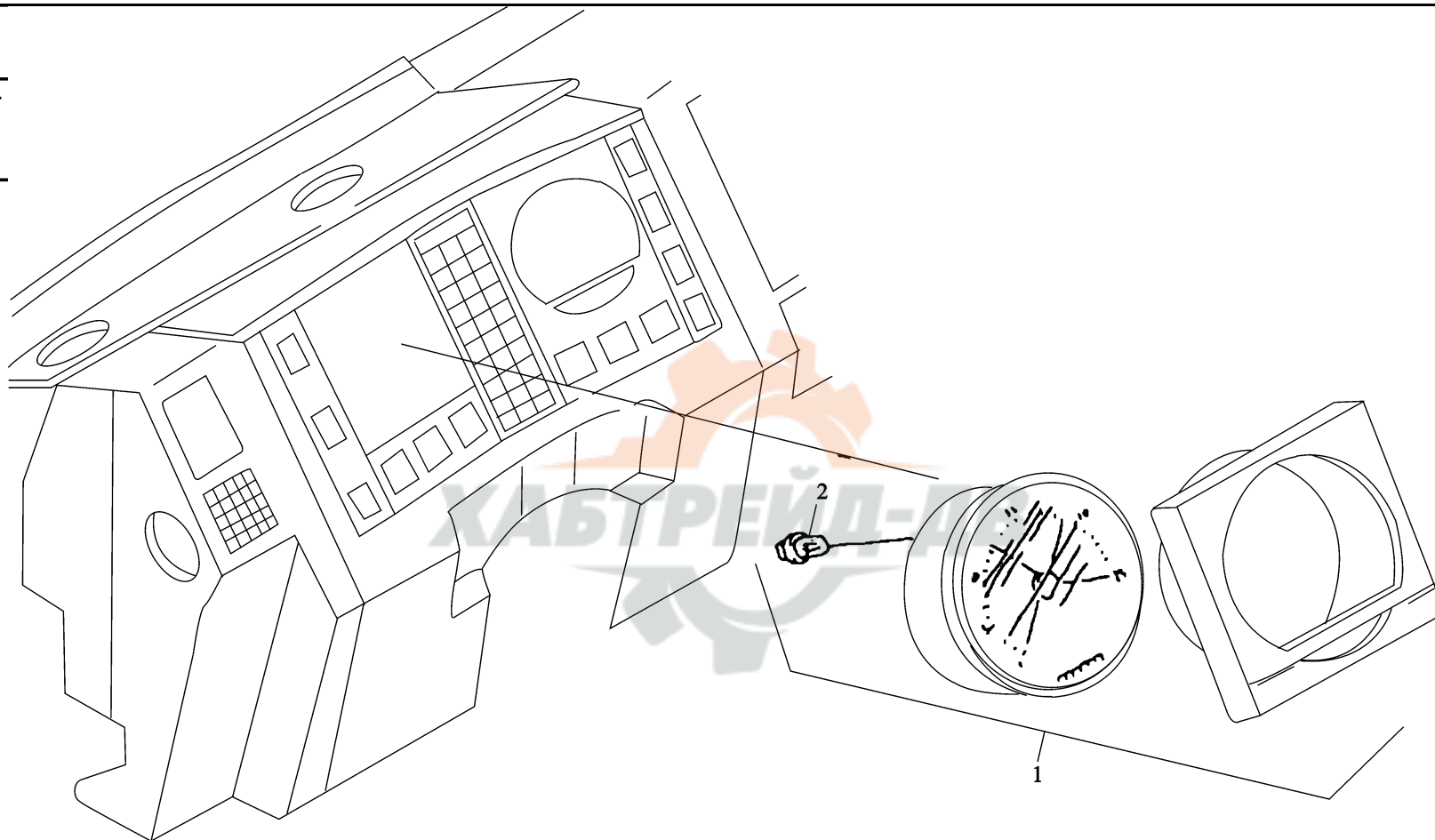

1	DZ9100586002	电子转速表（绍兴怡东 ZS2518φ10型）	Electronic tachometer	1		用于潍柴 WD615 玉柴发动机
	DZ9100586012	电子转速表（速比	Electronic tachometer	1		用于潍柴 WD618 发动机
	DZ9100586042	1:3.63）	Electronic tachometer	1		
2	81.25901.0086	电子转速表（怡东 ZS251 系列，速比 1:2.67）	Bulb with holder			用于康明斯 M11 系列发动机
		灯 泡				

信号灯 □ 戒      **WARNING LIGHT**

信号灯 □ 戒

序号 NO	件号 Part.No
----------	---------------

备注 Remark
--------------

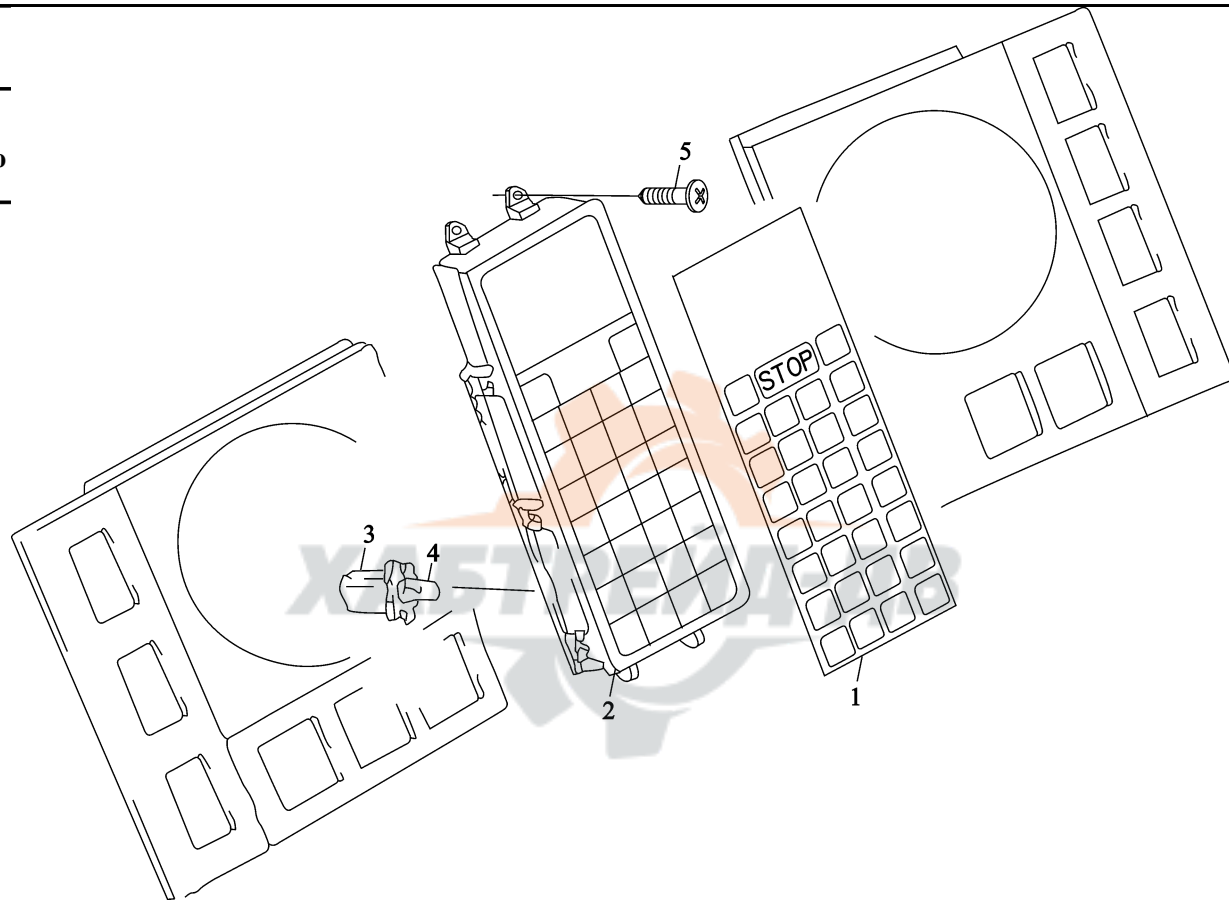

1	81.25210.6073	信号灯框架	Warning light frame	1		
2	82.25229.0065	信号灯符号板	Warning light sign board	1		
3	81.25901.0086	灯座 ( 24V.1.2W )	Socket	12		
4	81.25901.0076	灯泡 ( 24V.2.4W )	Bulb	12		
5	81.90470.0608	自攻螺钉	Screw	4		







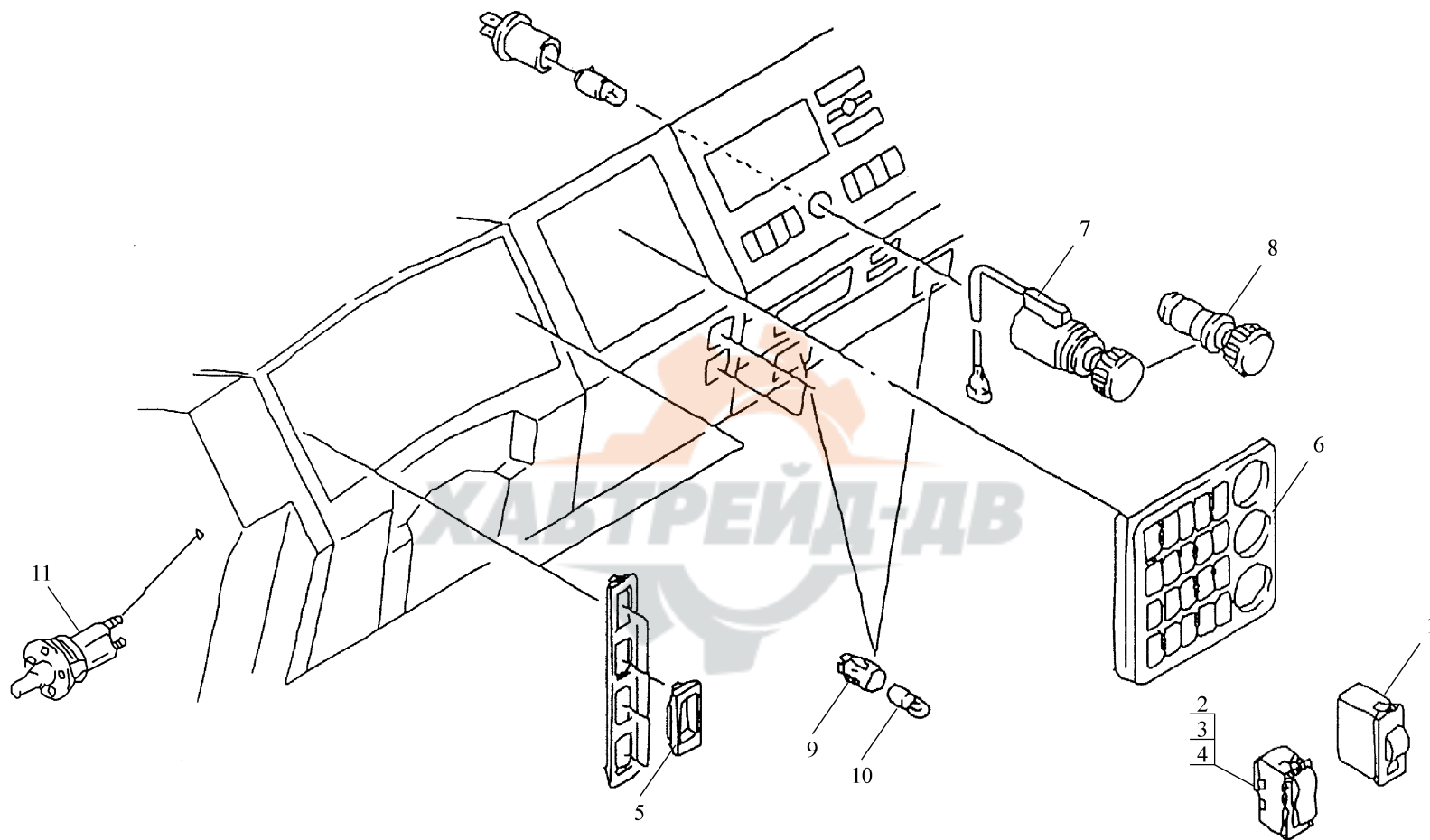





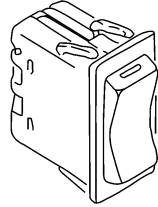





















































□ 板 □ □ 和 点 烟 器 SWITCH AND CIGARETTE LIGHTER

□ 标  
序 号  
NC



1	81.25907.0225	灯光亮度翘板开关	Lightness switch	1		
2	81.25505.6255	灯光翘板开关	Switch for light	1		
3	81.25503.6302	后雾灯翘板开关	Rear fog	1		
	81.25505.6607	雾灯翘板开关	Fog light switch	1		
4	81.25505.6291	危急报警翘板开关	Hazard signal switch	1		
5	81.61446.0014	翘板开关堵盖	Plug	4		
6	81.61701.0121	开关板	Switch board	1		
7	81.28901.0018	点烟器插座	Cigar lighter socket	1		
8	81.28901.0017	点烟器	Cigar lighter	1		
9	85.25236.0001	灯座（烟灰盒照明）	Socket	2		
10	81.25901.0043	灯泡（烟灰盒照明）	Bulb	2		
11	81.25505.0989	门灯开关	Door light switch	2		

□ 板 □ □ SWITCH

□ 板 □ □												备注	
序号 NO	件 Pa										备注 Remark		
													
													
											SET		
													
													
													



4	DZ9100586006	工作照明灯翘板开关	Working light switch	1		
6	81.25505.6262	后视镜电加热	Switch for mirror heating	1		
9	DZ9100586005	喇叭转换开关	Horn transition switch	1		
11	81.25505.6267	轮间差速锁翘板开关	Switch for differential lock	1		
23	81.25505.6280	轴间差速锁翘板开关	Switch for differential lock	1		
34	81.25505.6607	雾灯翘板开关	Fog lighter switch	1		
38	81.25503.6131	高顶驾驶室电动天窗翘板	Electric clearstory switch	1		
48	81.25505.6326	开关 高顶驾驶室内照明灯翘板	Read lighter switch	1		
49	81.25505.6327	开关	Electric clearstory switch	1		
54	81.25505.6291	高顶驾驶室天窗照明翘板	Hazard signal switch	1		
55	81.25505.6255	开关	Lighter switch	1		
56	81.25503.6302	开关	Rear fog light switch			
65		危急报警翘板开关 灯光翘板开关 后雾灯翘板开关 取力器翘板开关	Power take off switch			

# 带控制开关的空调系统 AIR CONDITIONING WITH CONTROL SWITCH

带控

序号

NO

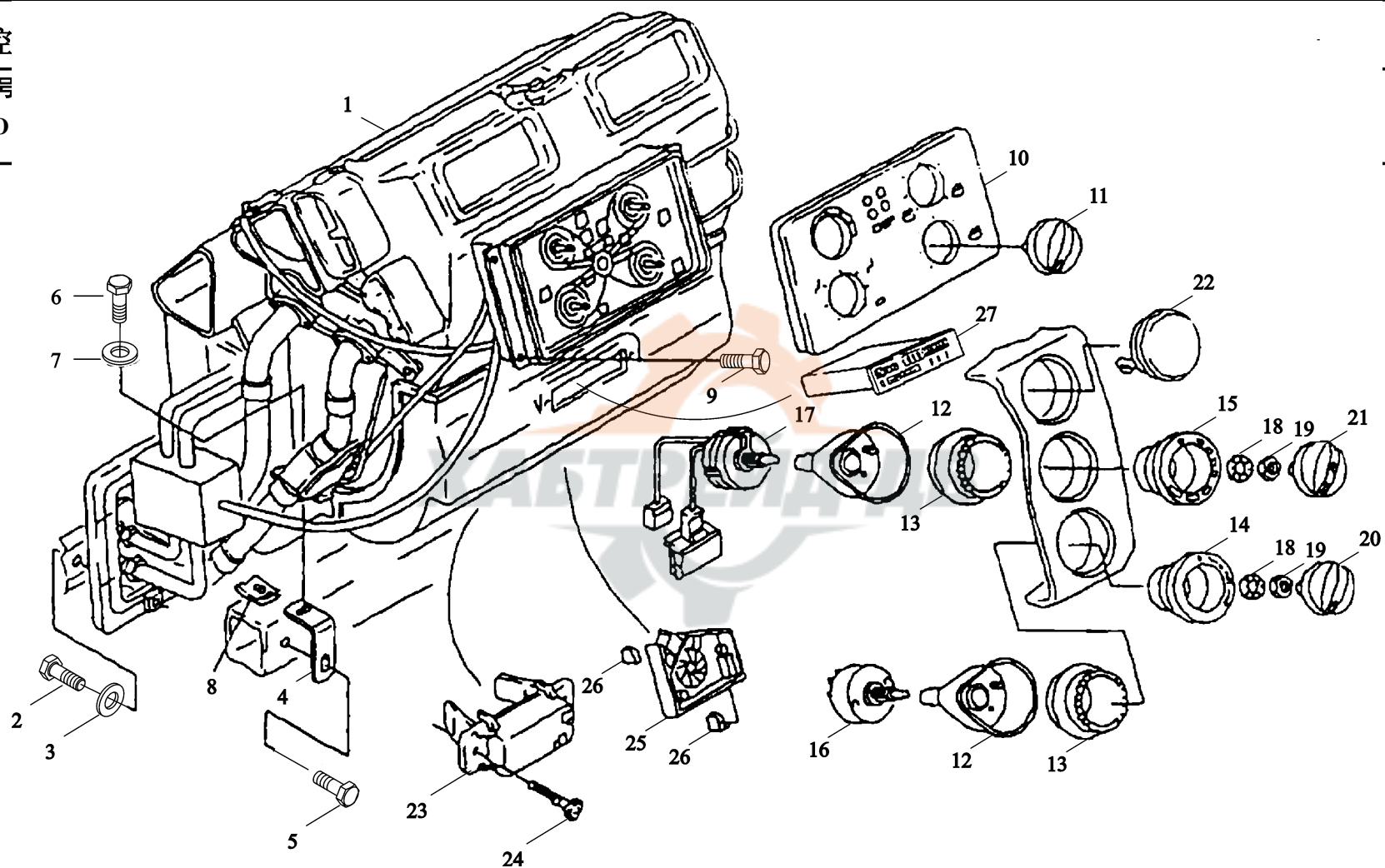

1	81.61900.6336	空调系统	Air conditioning	1	
2	06.01283.3115	六角螺栓	Hex bolt	6	M8×25-8.8-MAN183-B1
3	06.15013.0081	垫 圈	Washer	6	A8.4×16×1.6-200HV- MAN183-B1
4	81.61941.0134	角 板	Angle	2	
5	06.01303.3113	六角螺栓	Hex bolt	2	M8×16SK-8.8-MAN183-A2C
6	06.01283.2913	六角螺栓	Hex bolt	2	M6×16-8.8-MAN183-B1
7	06.15013.6109	垫 圈	Washer	2	6.4×18×1.6-140HV-MAN183-B1
8	06.13189.0056	簧片螺母	Slip-on nut	2	M6-16×20×4.0-C45-ZN
9	06.07151.1506	自攻螺钉	Oval-head self-tapping screw	4	
10	81.61990.0077	空调控制面板	Front plate	1	
11	81.61990.0074	空调工作模式开关旋钮	Rotary knob	1	
12	81.25516.0078	开关罩	Switch box	2	
13	81.25229.0554	发光元件	Luminous element	2	
14	81.61990.0072	符号环	Symbol ring	1	
15	81.91990.0071	符号环	Symbol ring	1	
16	81.25505.6171	加热器开关	Switch for heater	1	
17	81.25505.0975	开 关	Switch	1	
18	06.16089.0008	垫 圈	Serrated washer	2	A10.5-FST-MAN183-B1
19	06.11029.0024	六角螺母	Hexagon nut	2	M10×0.75-5-05-SW17-A2C
	06.11271.6402	六角螺母	Hexagon nut	2	BM10×1-04-MAN183-B1
20	81.61990.0074	空调工作模式开关旋钮	Rotary knob	1	
21	81.61990.0073	风扇开关旋钮	Rotary knob	1	
	81.25505.0728	锁止销	Locking pin	1	

# 带控制开关的空调系统 AIR CONDITIONING WITH CONTROL SWITCH

带控  
 序号  
 NO

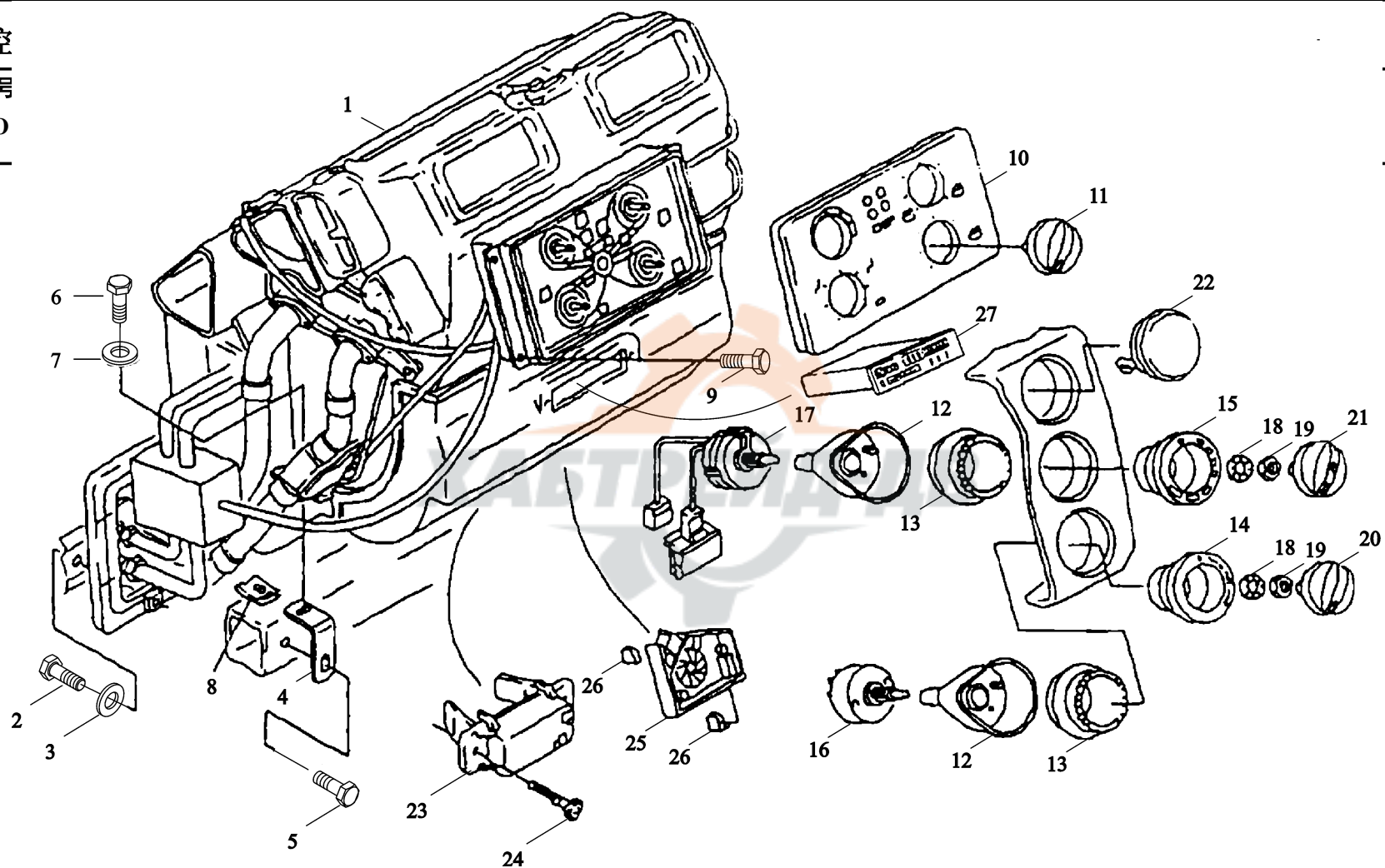

22	81.61701.0122	盖 板	Cover	1		
23	81.25935.6706	暖风电控单元	Electronic control unit blower	1		
24	81.90470.0611	螺 钉	Grooved raised head coll	2		
25	81.61930.6070	室内温度传感器	Blower with sensor	1		
26	06.43839.0074	U型夹子	U-clamp	2		
27	DZ9100788126	12V 收发机	Radio set	1		
	DZ9100789126	12V 收发机	Radio set	1		



# 暖风、空调开关 AIR CONDITIONING CONTROL SWITCH

暖风

序号

NO

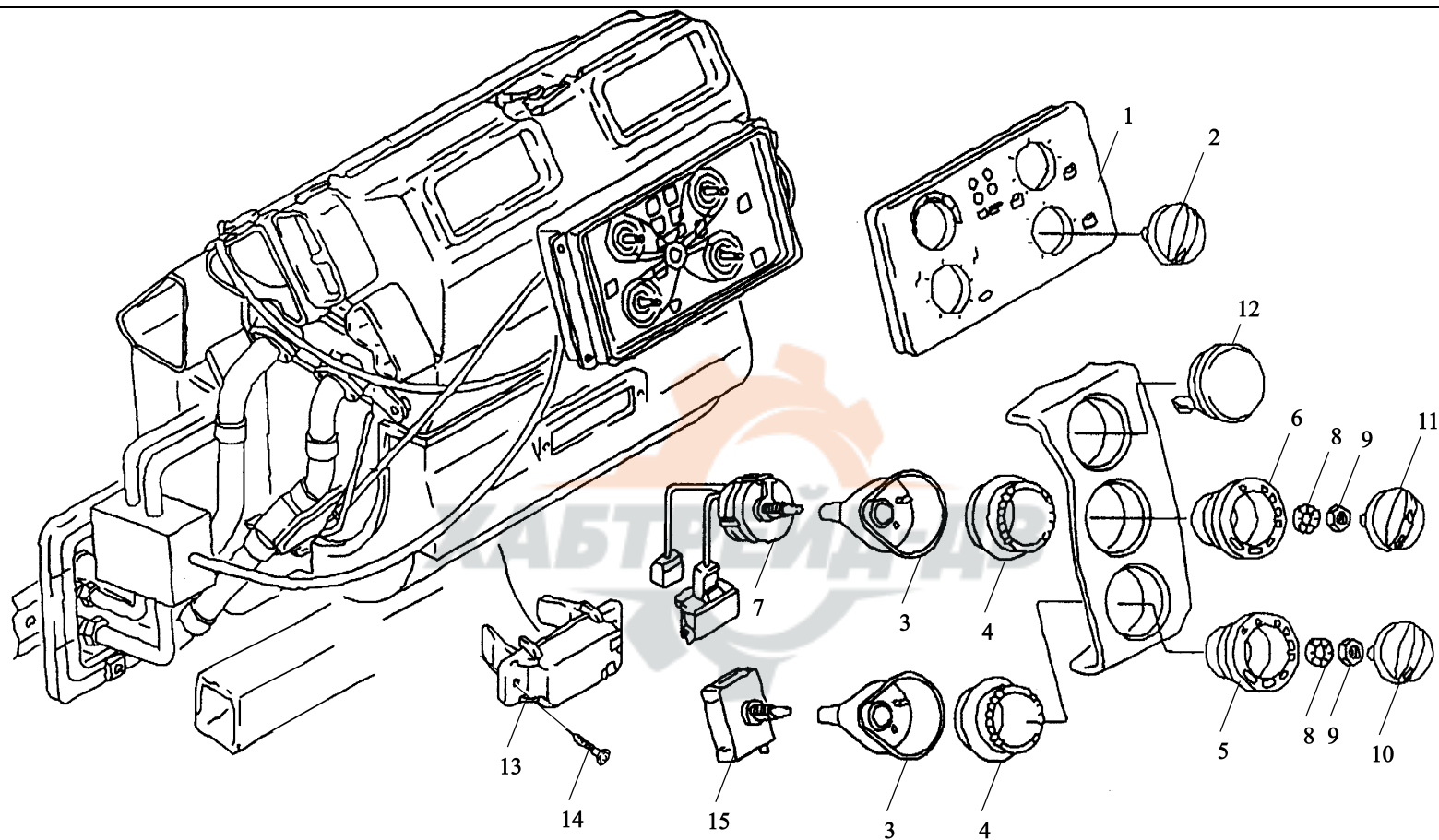

1	81.61990.0076	暖风控制面板	Heater control board	1		
2	81.61990.0074	旋 钮	Switch	4		
3	81.25516.0078	开关罩	Switch aap	2		
4	81.25229.0554	发光元件	Irradiance element	2		
5	81.61990.0072	符号环	Signal ring	1		
6	81.61990.0071	符号环	Signal ring	1		
7	81.25505.0975	空调开关本体	Switch body	1		
	81.25505.0959	暖风风扇开关本体	Heater fan switch body	1		
8	06.16089.0008	弹簧垫圈	Spring washer	2		
9	06.11029.0024	六角螺母	Hex nut	2		
10	81.61990.0074	空调工作模式开关旋钮	Switch	1		
11	81.61990.0073	暖风风扇开关旋钮	Switch	1		
12	81.61701.0122	盖 板	Cover	1		
13	81.25935.6706	暖风电控单元	Heater electric control	1		
14	81.90470.0611	十字槽盘头螺钉	element	2		
15	81.25505.6171	加热器开关	Screw Heater switch	1		

转向限止器 STEERING LOCK

转向限

序号
NO

注  
ark

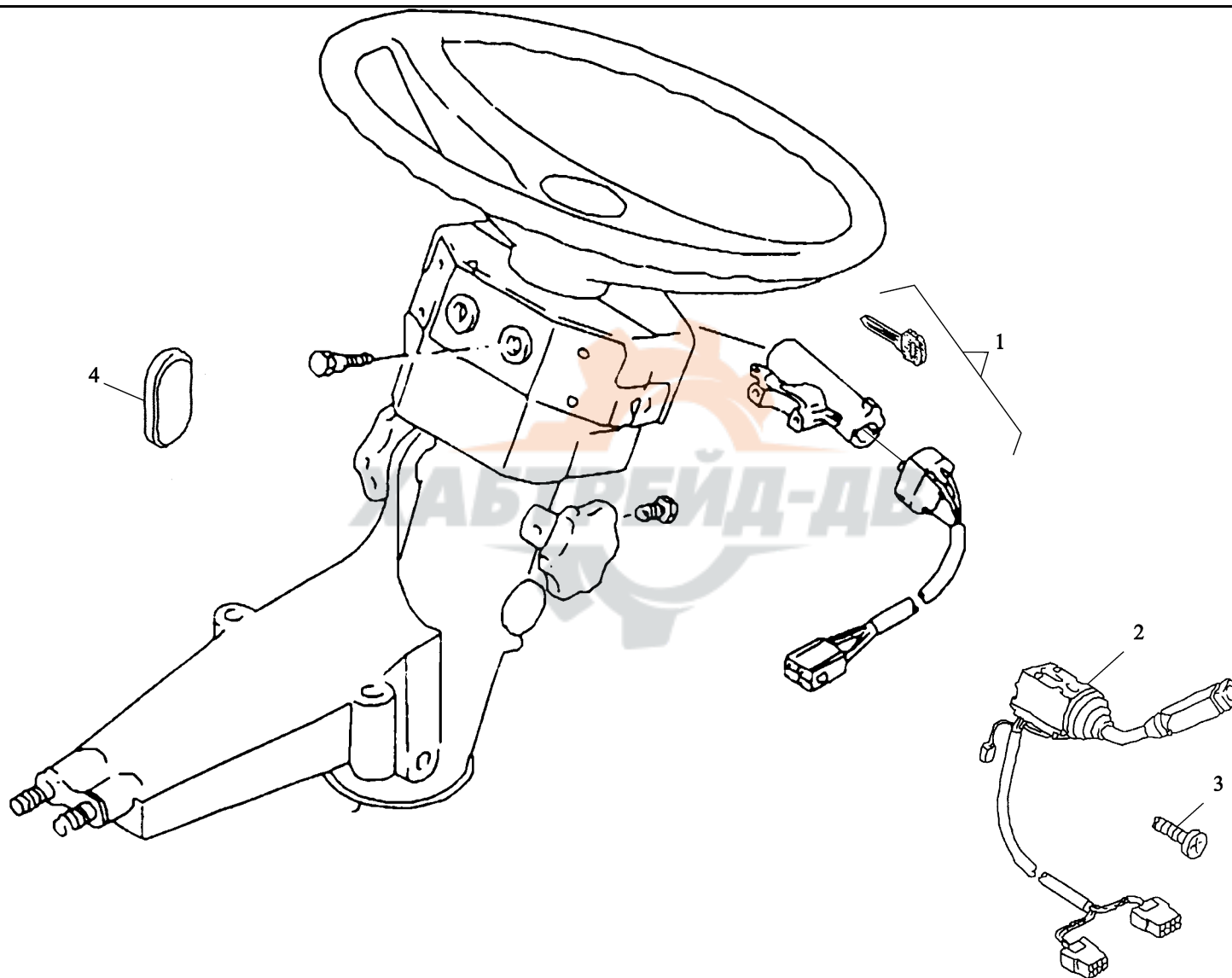



1	81.46433.6009	方向盘锁总成	Steering lock assembly	1		
2	81.25509.0124	组合开关	Combination switch	1		
3	06.04201.4503	平头螺栓	Flat screw	3		
4	81.46113.0088	橡胶堵盖	Rubber plug	2		

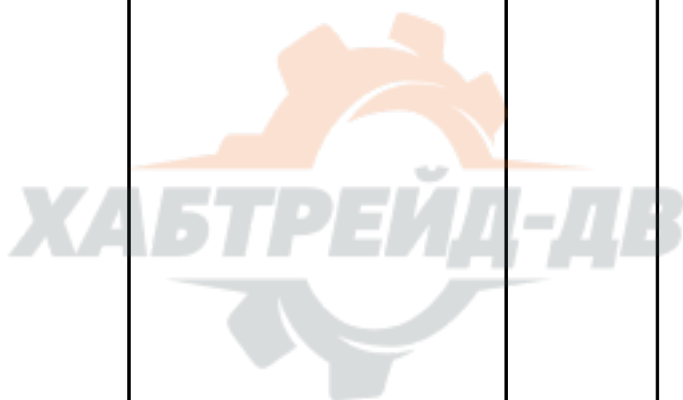

气 感 器 制 灯      SENSOR 、 BRAKE LIGHT SWITCH

气 感 器

序号 NO	件号 Part.No
----------	---------------

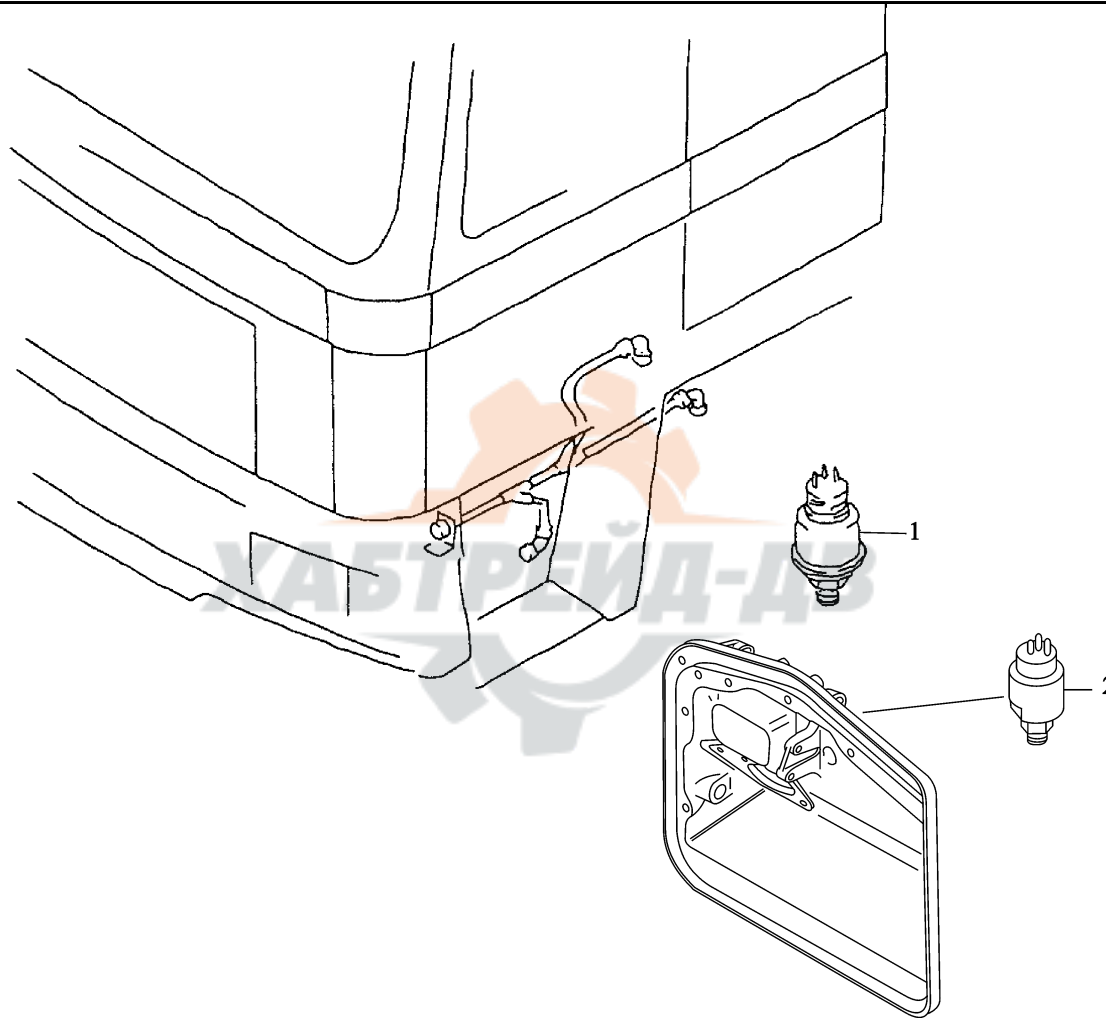

备注 Remark
--------------

1	81.27421.0151	气压传感器	Pressure sensor brake circuit	2		
2	81.25520.0171	制动灯开关	Brake light switch	1		



按 □ □ □ □ ( 排 气 制 □ ) EXHAUST BRAKE SWITCH

按 □ □

序号
NO.

注  
mark

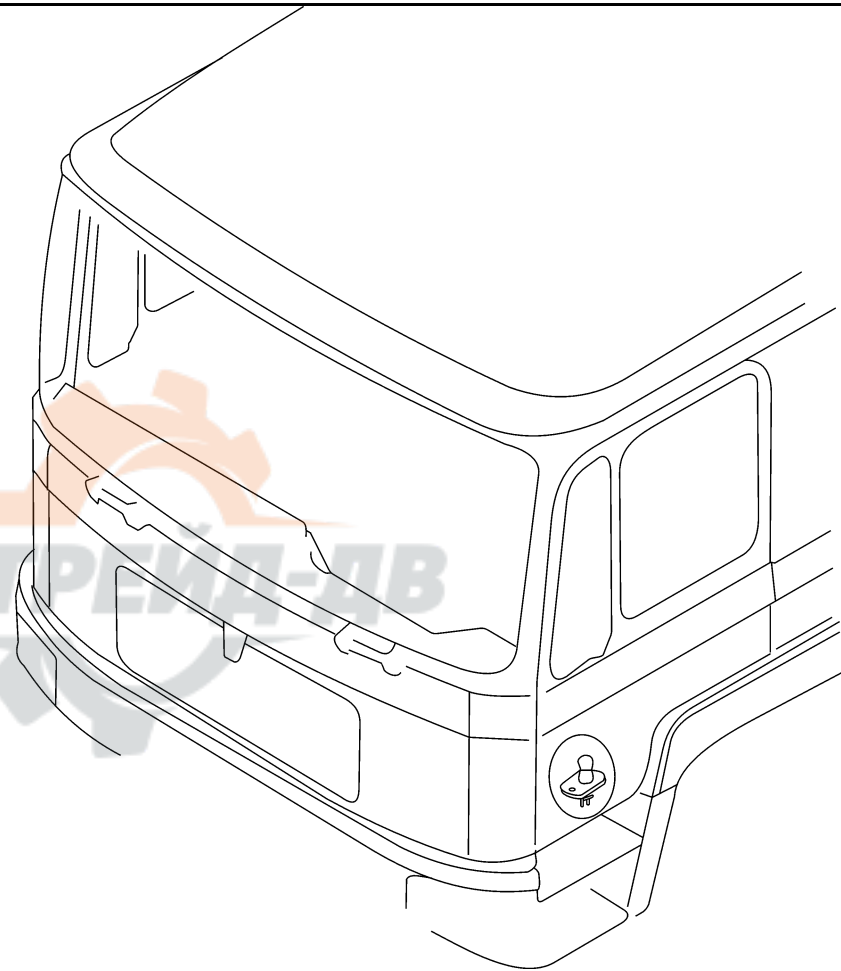
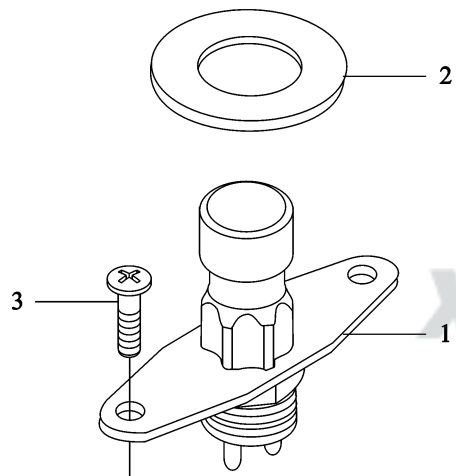

1	81.25505.0992	按钮开关（排气制动）	Button swtich	1		
2	81.96601.0690	橡胶垫	Cushion	1		
3	06.01470.0409	六角头带垫螺栓	Hex screw	2		



中央 □ 器 装 置 板 □ ( □ ) ELECTRIC PANEL I

中 央 □

序 号
NO

k

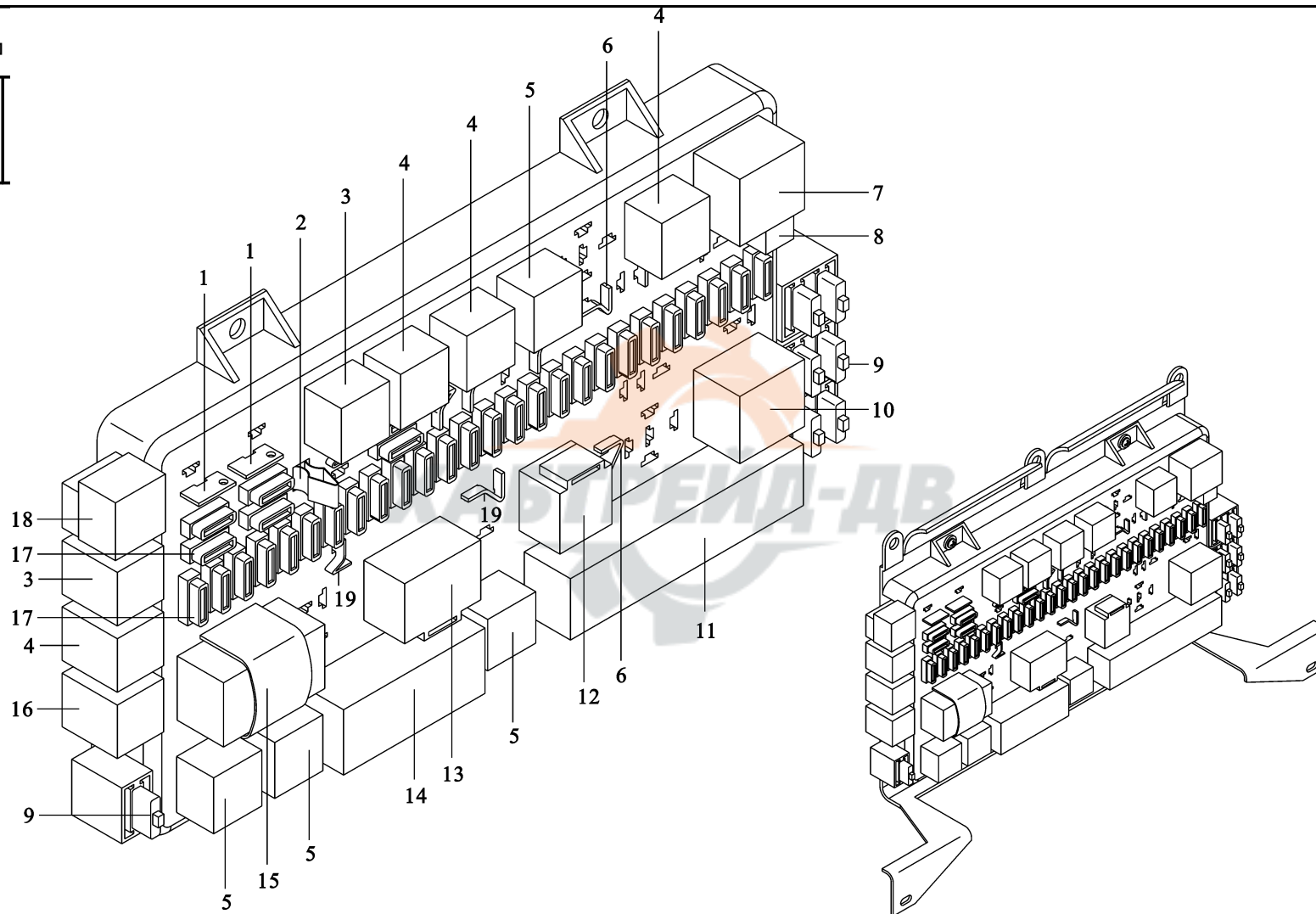

1	07.91203.0106	□ 接片	Connecting piece	2		
2	81.66818.0002	熔断□ 继电器	Insert pull tools	1		
3	81.25902.0410	□ □ 器	Relay	2		
4	81.25902.0459	□ □ 器	Relay	4		
5	81.25902.0460	□ □ 器	Relay	4		
6	07.91203.0104	□ 接片 (□ 插)	Connenting piece (long)	3		
7	81.25902.0317	中央□ □ 器	Center relay	1		
8	81.25927.0107	二极管	Diode	1		
9	81.25437.0118	断路器 (7.5/8A)	Turn off implement	4		
	81.25437.0119		Turn off implement	1		
	81.25437.0120		Turn off implement	2		
10	81.25902.0415	断路器 (10A)	Load relay	1		
11	81.25902.0497	断路器 (15A)	Blame glow element	1		
12	81.25902.0378		Exhausting brake relay	1		
13	81.25902.0376	□ □ □ □ 器	Time-lapse relay	1		
14	81.25311.0023	□ □ 控制器	Control element	1		
15	81.25311.0006	排气制□ □ 速□ □ 器	Flash relay	1		
16	81.25927.0099	延□ □ □ 器	Air-conditional diode	1		
17	81.25436.0065	雨刮 - □ 光□ 隙控制器	Red fuse	16		
	81.25436.0066		Blue fuse	6		
	81.25436.0067	□ 光□ □ 器	Yellow fuse	3		
	81.25436.0068	空□ 二极管	White fuse	2		
	81.25436.0079	□ 色熔断□	Orange fuse	2		
18	81.25902.0469	□ 色熔断□	Rear fog light relay	1		
19	07.91203.0105	黄色熔断□	Connecting piece (short)	6		

中央 □ 器 装 置 板 □ ( □ □ )

CENTER ELECTRIC PANEL II

中 央 □

序 号

NO

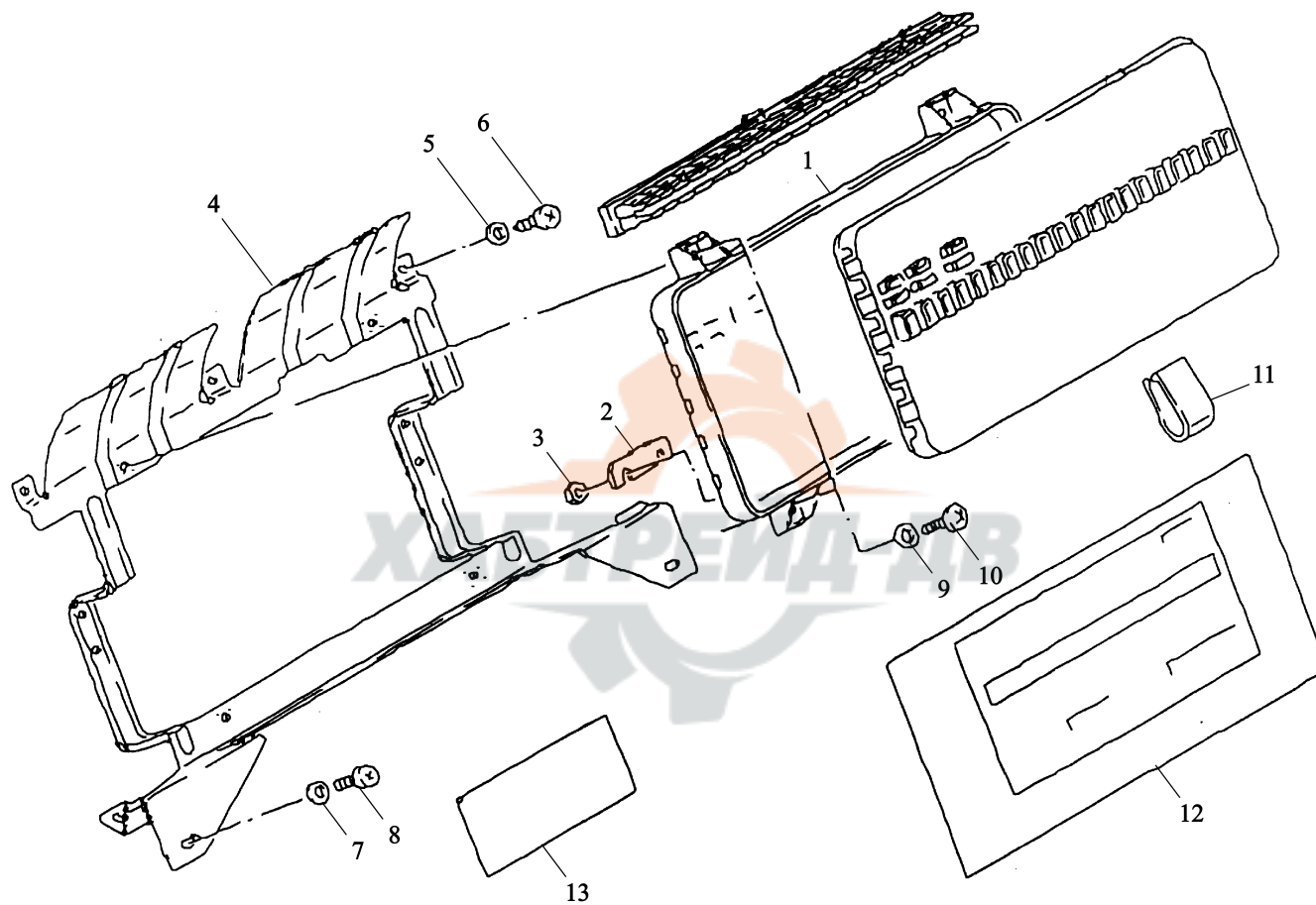



1	81.25444.6060	中央电器装置板	Center electric panel	1		
2	81.25908.0010	两孔连接片	Connecting plate	1		
3	06.11064.2112	六角螺母	Hex nut	2		
4	81.25441.5217	中央电器装置板支架	Bracket	1		
5	06.15013.0407	平垫圈	Flat washer	3		
6	06.07151.1503	十字槽盘头自攻螺钉	Screw	3		
7	06.15190.0307	平垫圈	Washer	3		
8	06.04201.6607	平头自攻螺钉	Screw	2		
9	06.15013.0409	平垫圈	Washer	4		
10	06.04201.4609	平头自攻螺钉	Screw	4		
11	81.66818.0001	继电器插拔器	Pull insert tools	1		
12	DZ9100586100	中央电器装置板	Center electric panel	1		中文标志牌 Chinese trade
	DZ9100586110	中央电器装置板	Center electric panel	1		mark
13	81.61460.2036	保护垫	Cushion	2		英文标志牌 English trade
						mark

恒温空□控制元件 ELECTRONIC CONTROL UNITS FOR AIR CONDITIONING

恒温  
序号  
NO

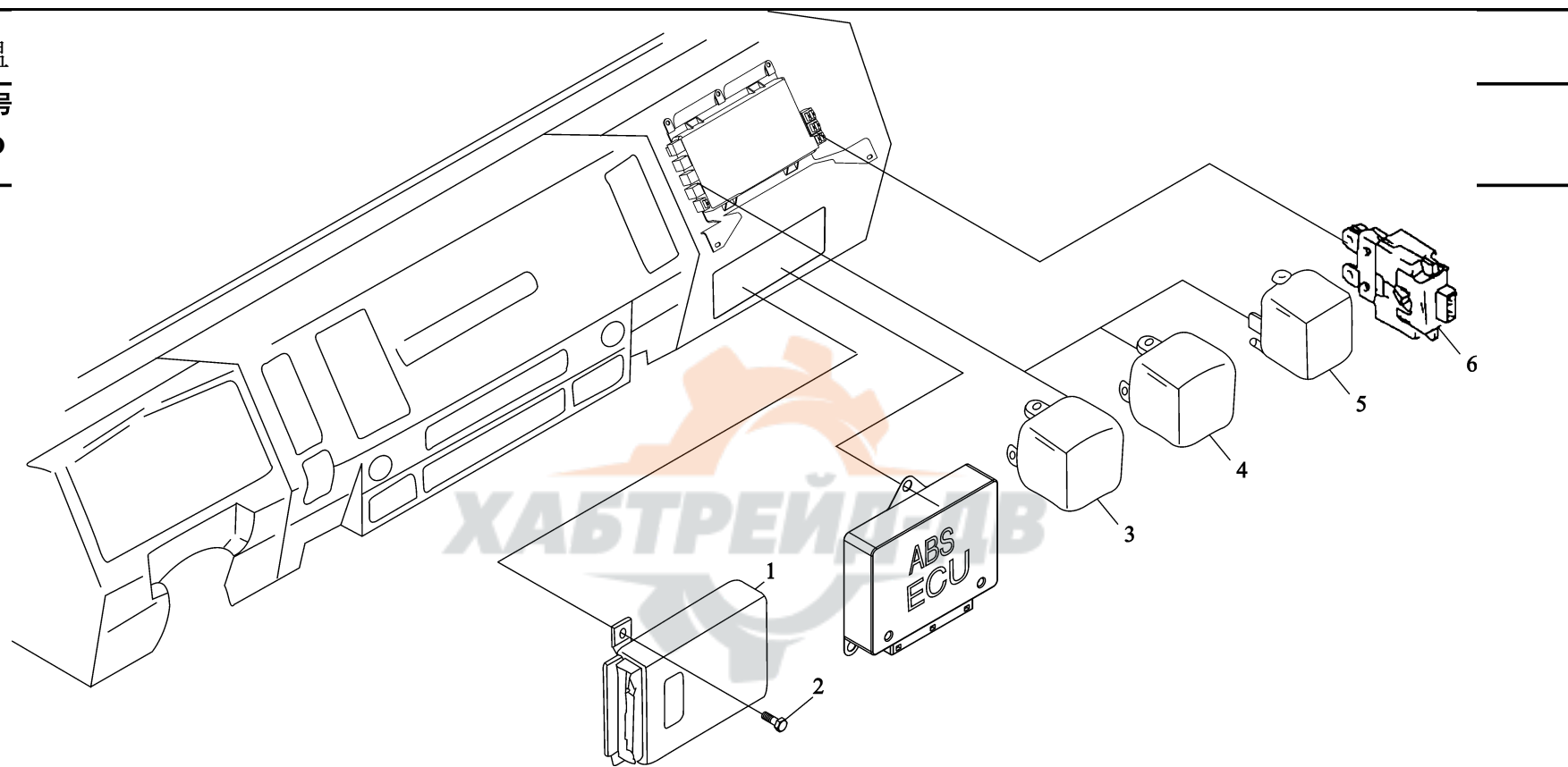

1	81.25935.6660	空调电控单元	Electric unit for air conditioning	1		
2	Q2140620	十字槽盘头螺钉	Screw	2		
3	81.25902.0410	继电器	Relay	1		
4	81.25902.0459	继电器	Relay	1		
5	81.25927.0099	二极管（压缩机电磁开	Diode	1		
6	81.25437.0118	关） 断路器	Turn off implement	1		7.5A/8A



收 放 机 □ 声 器 □ □ □ 器 吸 □ 接 □ 束

RADIO LOUD HAILER TRANSFORMER WIRE

收  
序

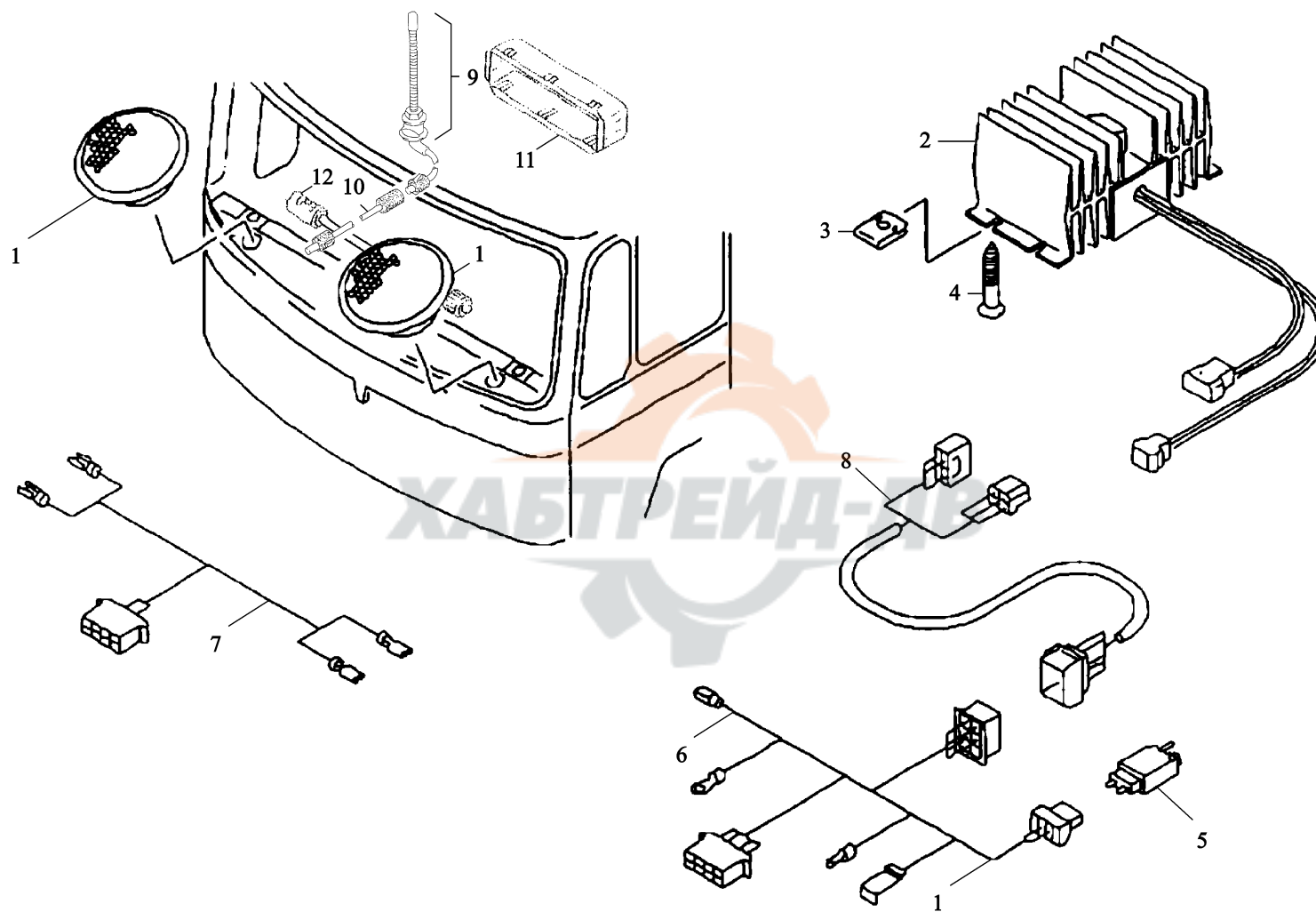

1	81.28102.6066	扬声器	Loud hailer	2		
2	81.25907.0269	变压器	Transformer	1		24V/12V
3	06.13189.0112	簧片螺母	Speed nut	2		
4	06.07158.4503	圆柱头自攻螺钉	Screw	2		
5	81.25436.0065	红色熔断丝	Red fuse	1		10A
6	81.25417.6647	收放机电线束	Radio wiring harness	1		12V
7	81.25416.6739	扬声器电线束	Loud hailer wiring harness	1		
	81.25417.6080	扬声器电线束	Loud hailer wiring harness	1		
8	81.25417.6646	变压器电线束	Transformer wiring harness	1		右置车 to right
9	81.28205.0054	天线总成	Antenna	1		
10	81.28104.0033	馈线	Feed back wire	1		
11	81.28140.0078	保持架	Retaining frame	1		4000mm
12	81.28104.0015	天线线束	Aerial wire extension	1		5000MM

前照灯 □ 或 □ ( □ □ 向灯 )

HEADLAMPS WITH FLASHER

前照灯

序号
NO

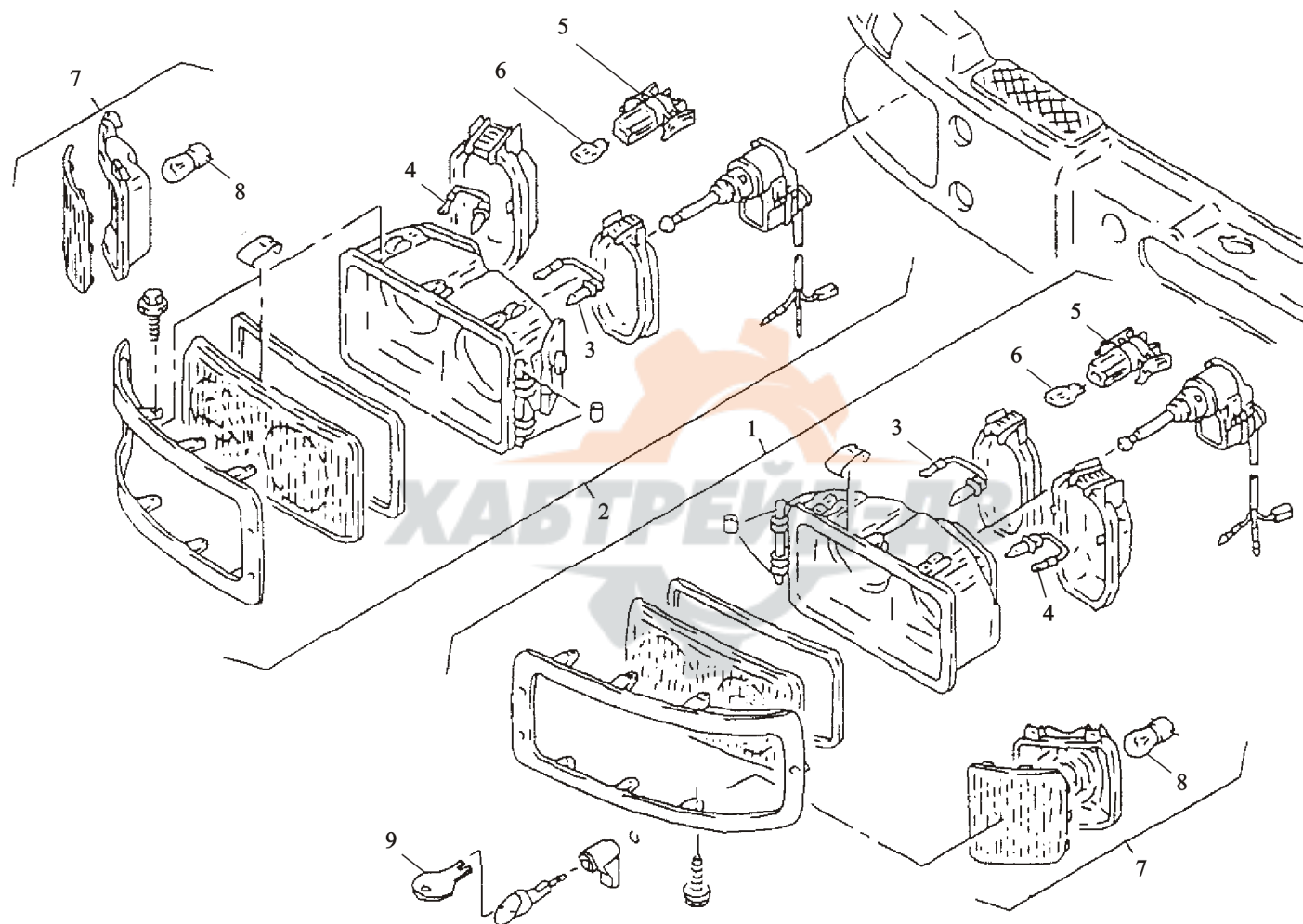

E  
rk

1	81.25101.6289	前照灯总成 (左)	Headlamps assembly left	1		
	81.25101.6293	前照灯 (左)	Headlamps left	1		
2	81.25101.6290	前照灯总成 (右)	Headlamps assembly right	1		右置车 to right
	81.25101.6294	前照灯 (右)	Headlamps right	1		
3	81.25901.0091	灯 泡	Bulb	2		右置车 to right
4	81.25901.0091	灯 泡	Bulb	2		
5	81.25236.0050	灯 座	Socket for bulb pa6	2		H7-24V-70W-HG
6	81.25901.0093	灯 泡	Miniature bulb	2		H7-24V-70W-HG
7	81.25320.6082	转向灯	Flasher	2		( PA6 )
8	81.25901.0075	灯 泡	Bulb	2		
9	81.97118.0028	钥匙 (前照灯)	Key for headlamps	1		LD24V-5W-W2.1×9.5D
						P21W-24V-BAY15S-HD

前 灯 HEADLIGHTS AND FOGLIGHTS

前 灯

序号
NO

注  
ark

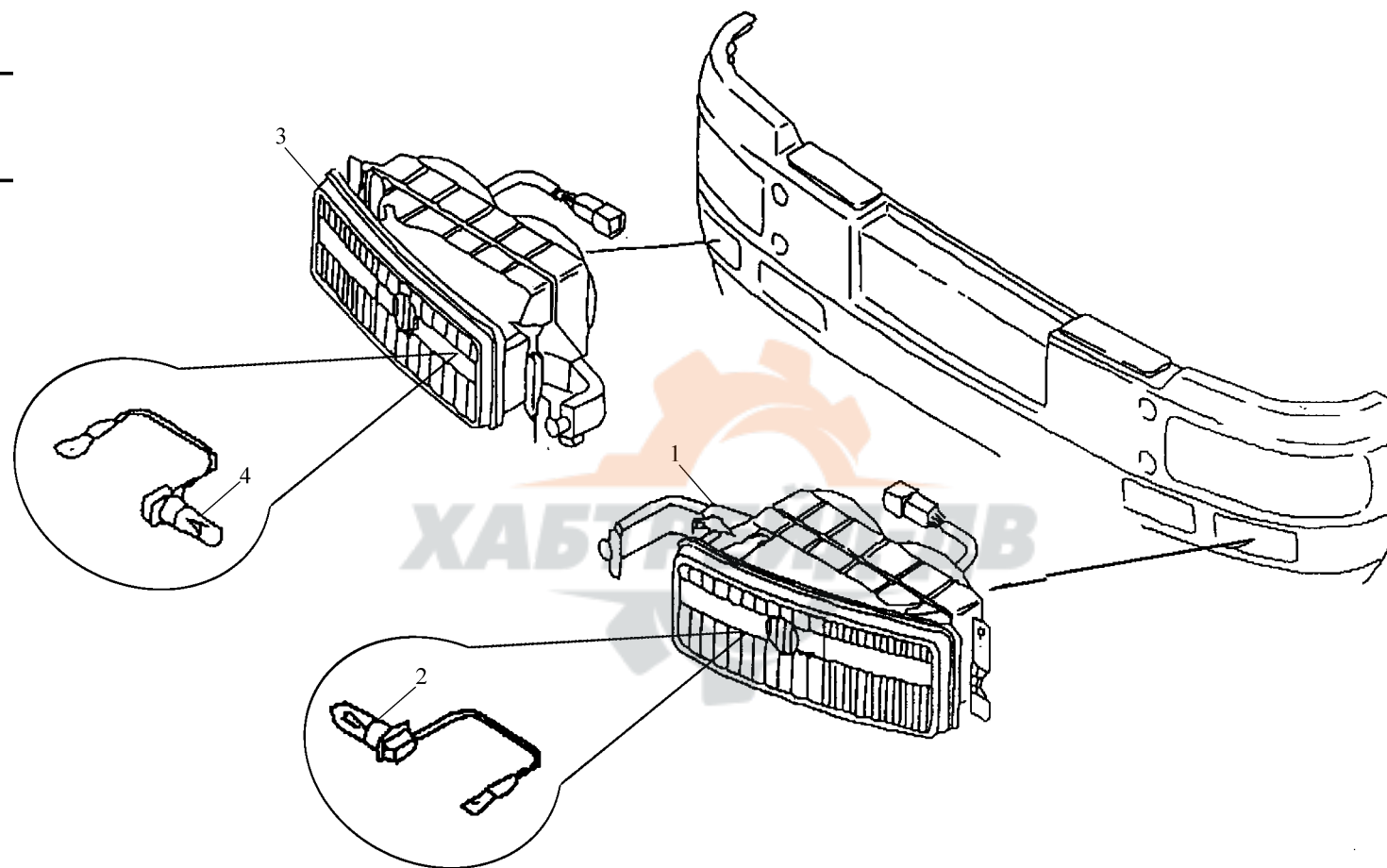



1	81.25101-6339	辅助前照灯总成（左）	Headlights and foglights left	1		雾灯 辅助远光灯
2	81.25901.0027	灯 泡	Bulb	2		H3-24V-70W
3	81.25101.6338	辅助前照灯总成（右）	Headlights and foglights right	1		雾灯 辅助远光灯
4	81.28901.0027	灯 泡	Bulb	2		H3-24V-70W



□ 向灯 (保 □ 虹) FLASHERS IN BUMPER

□ 向灯 (保 □ 虹)

序号 NO	件号 Part.No
----------	---------------

备注 Remark
--------------

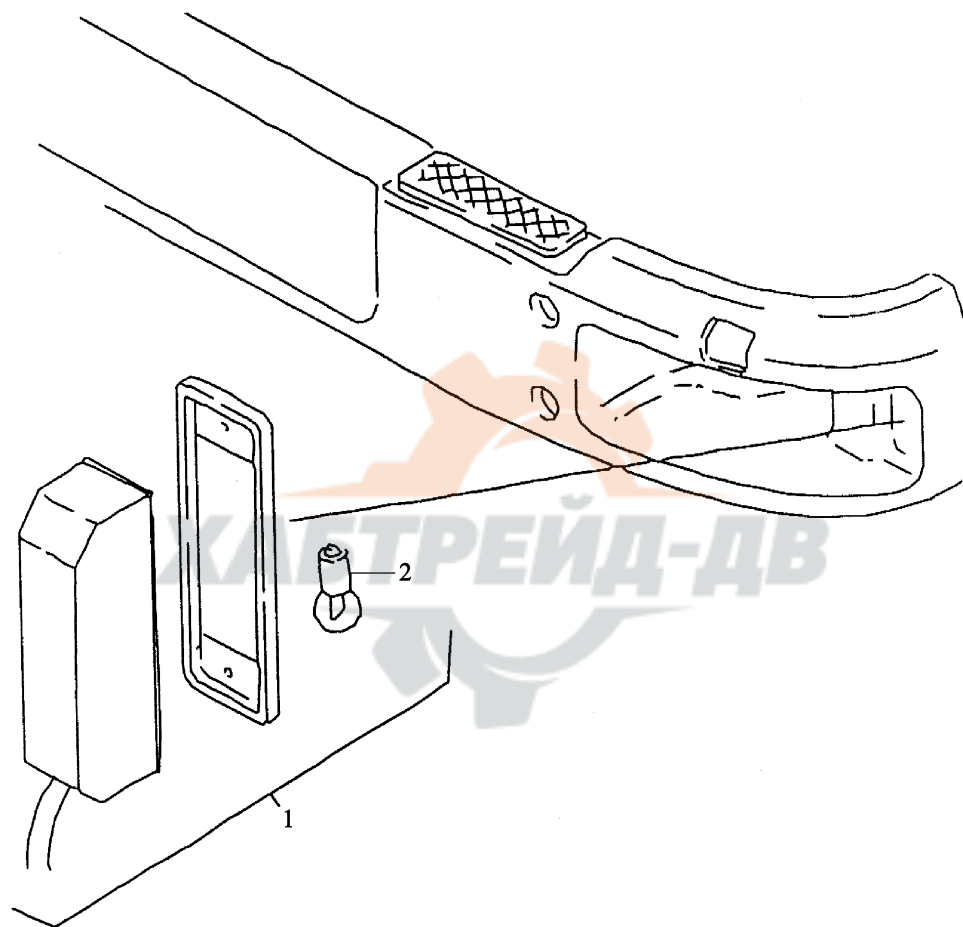

1	81.25320.6082	转向灯	Flashers	2		
2	81.25901.0075	灯泡 (24V.21W)	Bulb	2		



□ 后灯及底 □ □ 器

REAR LIGHT AND CHASSIS WIRING

□ 后  
序号  
NO

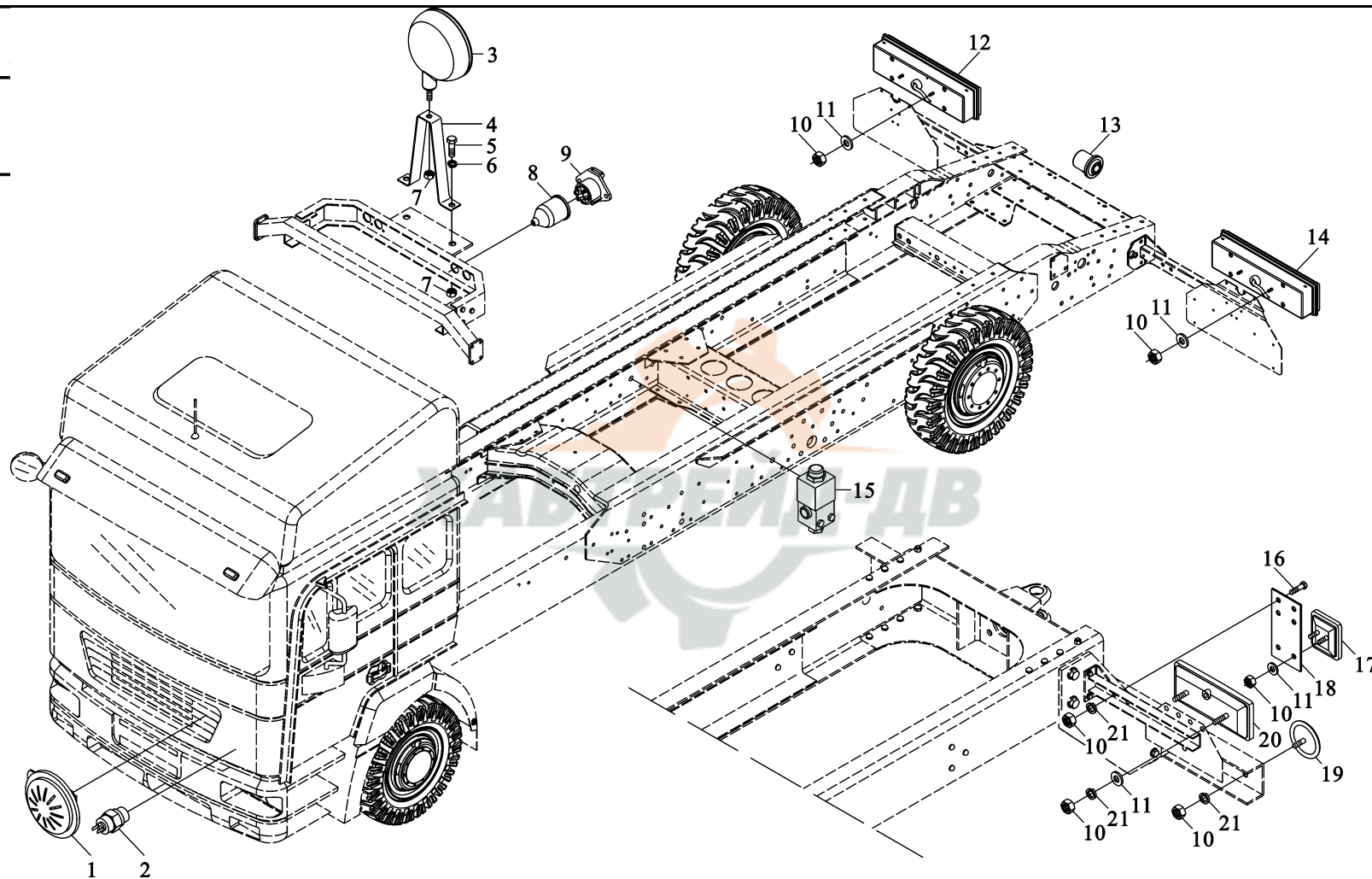

1	81.25301.6066	电喇叭	Electric horn	1		
2	79100710005	气压信号灯开关	Air prissure signal switch	1		
3	DZ9100720110	工作灯总成	Working lamp assy	1		
4	DZ9100726010	工作灯支架	Racket	1		
5	Q150B0820	六角头螺栓	Hex screw	2		
6	Q40508	重型弹簧垫圈	Spring washer	2		
7	Q340B08	六角螺母	Hex nut	3		
8	99012710014	保护套	Protective case	1		
9	90003499855	七孔挂车插座	7 hole trailer socket	1		
10	Q304B06	六角螺母	Hex nut	18		24N 型 7 孔插座
11	Q40206	大垫圈	Washer	12		
12	AZ9200810010	T/带侧标志灯 7 功能组	Combination camp (right)	1		
13	DZ9100580050	合后灯 (右)	Reverse buzzer	1		
14	AZ9200810009	倒车蜂鸣器	Combination camp (left)	1		
15	AZ9100719008	T/带侧标志灯 7 功能组	Magnetic valve	按需		
16	Q150B0616	合后灯 (左)	Hex screw	4		(北方)
17	79100810013	电磁阀	Rear fog light	2	载货车	
18	79100810018	六角头螺栓	Plate	2		
19	89000810001	T/后雾灯	Echo device	2	载货车	
	AZ9100810001	固定板	Echo device	2	载货车	
	AZ9100819001	T/反射器	Echo device assy	2	载货车	
20	79100810045	T/反射器	Combination lamp (left)	1	载货车	

□ 后灯及底 □ □ 器

REAR LIGHT AND CHASSIS WIRING

□ 后  
 序号  
 NO

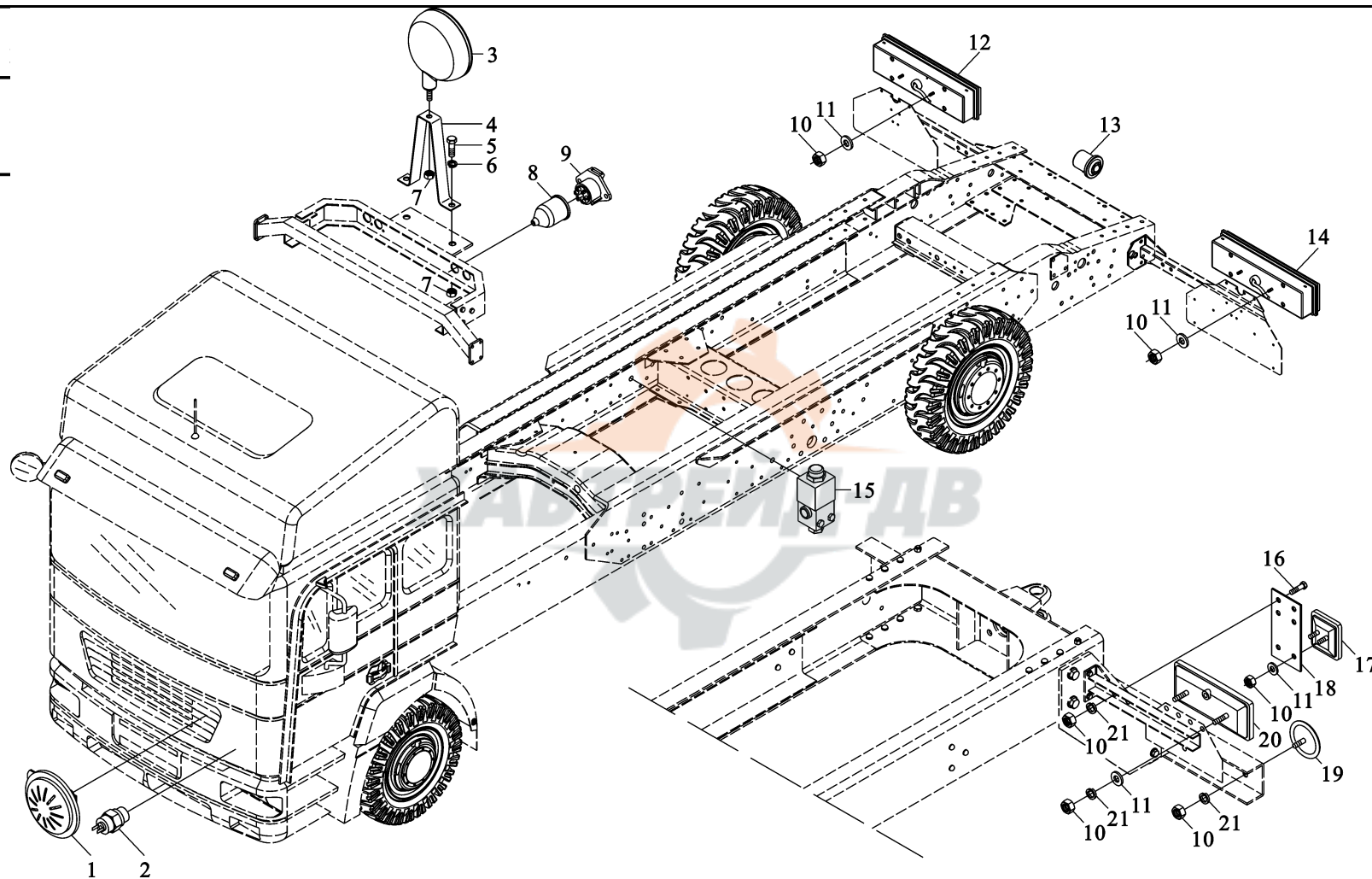

21	79100810046	T/右组合后灯	Combination lamp (right)	1	载货车	尾灯-制动灯-闪光灯 (济南)
	AZ9100818046	T/右组合后灯	Combination lamp (right)	1	载货车	
	Q40506	重型弹簧垫圈	Spring washer	10		



# 侧标志灯（翼子板） SIDE MARKER LIGHT

## 侧标志灯（翼子板）

序号 NO	件号 Part.No

备注 Remark

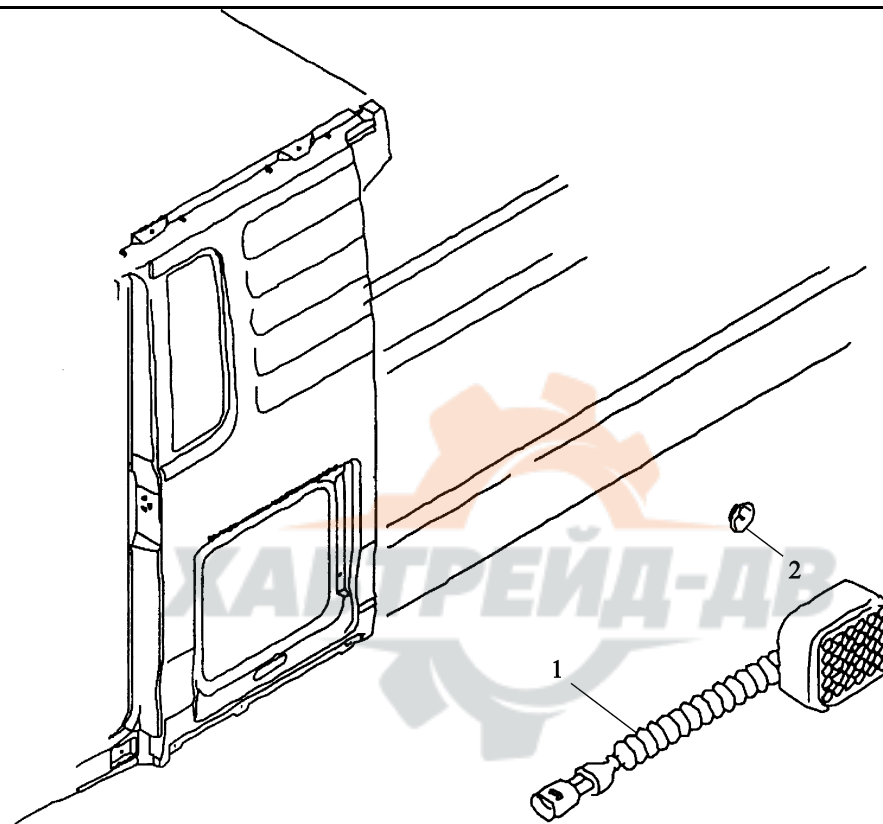



1	81.25260.6101	侧标志灯 (1250mm 电线)	Side marker lamp	2		
2	81.90820.0340	锁止垫圈	Locking washer	4		



照明灯 (高口) FLOODLIGHT (HIGH ROOF)

照明灯

序号
NO

注  
mark

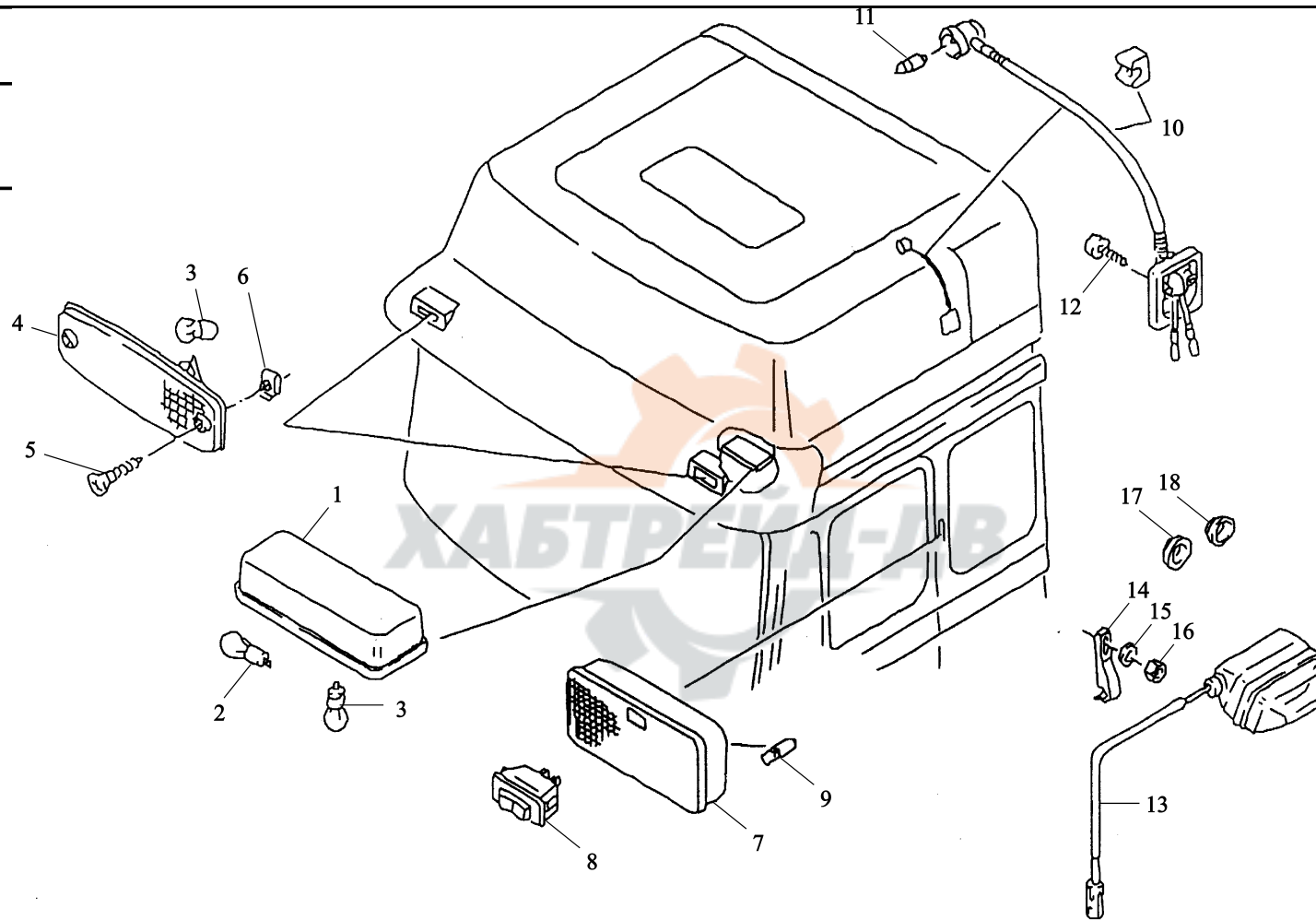

1	81.25201.6188	驾驶室内照明灯（带阅读灯）	Floodlight in cab	2		
2	81.25901.0075	灯泡（24V.21W）	Bulb	2		
3	81.25901.0074	灯泡（24V.10W）	Bulb	4		
4	81.25260.6040	示高灯	High position lamp	2		
5	06.07171.1506	自攻螺钉	Screw	4		
6	06.13189.0112	簧片螺母	Speed nut	4		
7	81.25201.6207	驾驶室后围照明灯	Rear floodlight	1		
8	81.25503.0270	高顶驾驶室电动天窗翘板	Electronic clearstory switch	1		
9	81.25901.0090	开关（后围）	Bulb	2		
10	81.25202.6006	灯泡（12V.6W）	Read lamp	1		
11	81.25901.0069	圆形阅读灯	Bulb	1		
12	06.07158.4503	灯泡（12V.5W）	Screw	2		
13	81.25416.6776	圆柱头自攻螺钉	Step light wire	2		
14	81.97440.0219	左、右车门踏步灯电线束	Clip	2		
15	06.15190.0307	电线紧固夹（固定线束）	Washer	2		
16	06.11064.2112	垫圈	Hex nut	2		
17	81.96001.0481	六角螺母	Rubber ring	2		
18	81.96001.0482	穿线胶圈（驾驶室本体）	Rubber ring	2		

□ □ 室内照明灯 (平 □ 卩 FLOODLIGHT (STANDARD))

□ □ 室内

序号	
NO	

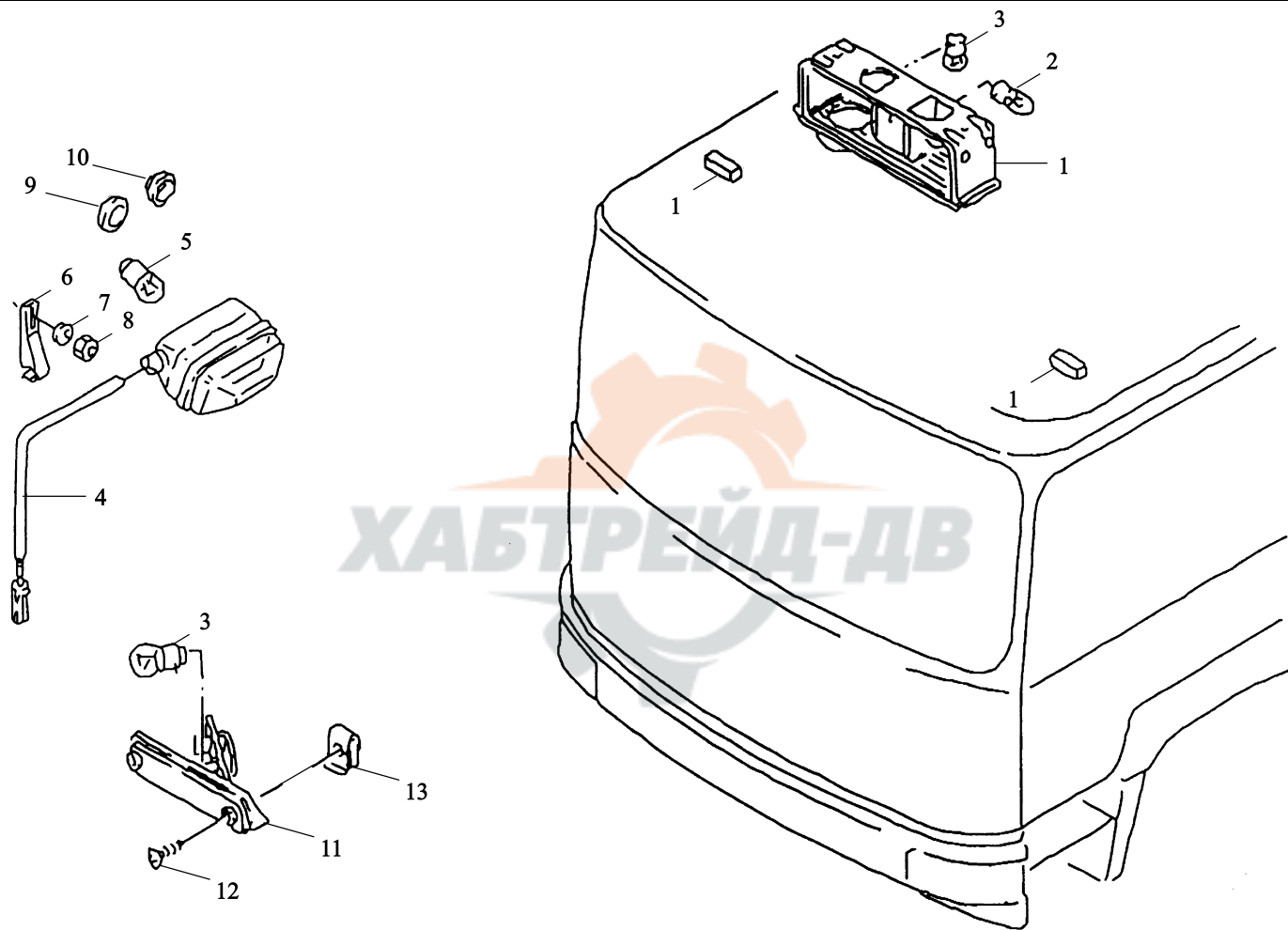

注	
emark	

1	81.25201.6188	驾驶室内照明灯（带阅读灯）	Floodlight in cab	2		
2	81.25901.0075	灯泡（24V.21W）	Bulb	2		
3	81.25901.0074	灯泡（24V.10W）	Bulb	2		
4	81.25416.6776	灯泡（24V.10W）	Bulb	2		
5	81.25901.0073	左、右车门踏步灯电线束	Clip	2		
6	81.97440.0219	左、右车门踏步灯电线束	Washer	2		
7	06.15190.0307	左、右车门踏步灯电线束	Hex nut	2		
8	06.11064.2112	灯泡（24V.5W）	Rubber ring	2		
9	81.96001.0481	灯泡（24V.5W）	Rubber ring	2		
10	81.96001.0482	电线紧固夹	Rubber ring	2		
11	81.25260.6057	垫圈	High position lamp	2		
12	06.07171.1506	六角螺母	Screw	4		
13	06.13189.0112	穿线胶圈（驾驶室本体） 穿线胶圈（车门本体） 示高灯 自攻螺钉 簧片螺母	Speed nut	4		

# 后围照明灯 FLOODLIGHT ON REAR PANNEL

## 后围照明灯

序号 NO	件号 Part.No
----------	---------------

备注 Remark
--------------

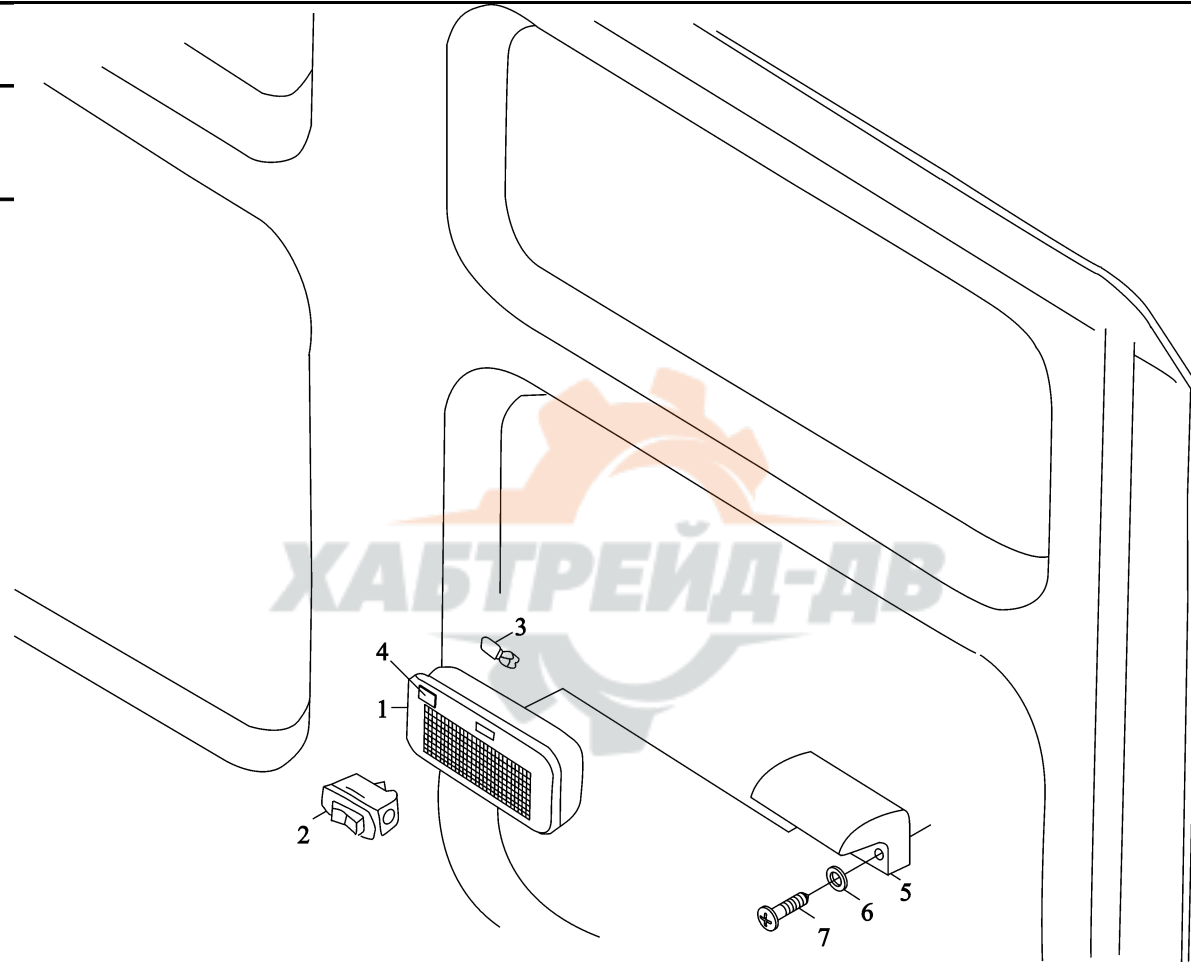

1	81.25201.6207	驾驶室后围照明灯	Light on rear pannel	2		
2	81.25505.0904	开 关	Rocker switch	2		
3	81.25901.0090	灯 泡	Miniature bulb	4		LD12V-6W-W2,1×9.5D
4	81.61446.0037	翘板开关盖板	Cover	2		44MM×24MM
5	81.25245.0143	驾驶室后围照明灯框架	Adapter	2		
6	06.07158.1409	自攻螺丝	Oval-head self-tapping screw	2		9×38C-H-A3R
7	06.15019.0065	垫 圈	Washer	2		A4.3×9×0.8-200HV-MAN183-B1



后围照明灯框架 ADAPTER

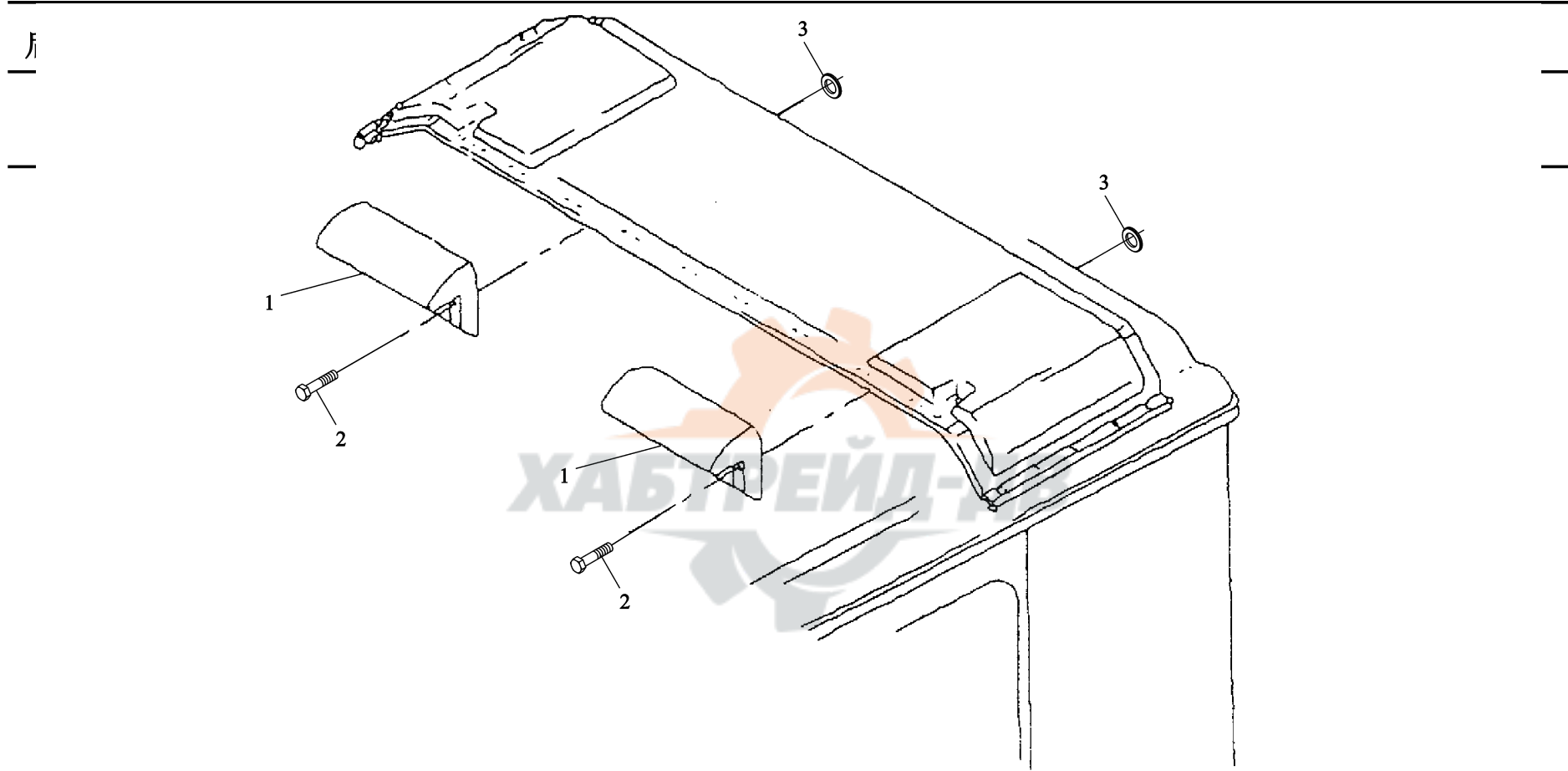



1	81.25245.0143	□ □ 室后□ 照明灯框架	Adapter	1		
	81.62740.0067	□ □ 室后□ 照明灯框架	Adapter	1		
2	06.07158.1409	自攻螺□	Oval-head self-tappingscrew	2		9×38C-H-A3R
3	06.15019.0065	□ 圈 □	Washer	2		A4.3×9×0.8-200HV-MAN183-B1
	06.15013.0407	□ 圈 □	Washer	2		



# 蓄 池 箱 BATTERY BOX

蓄  
序

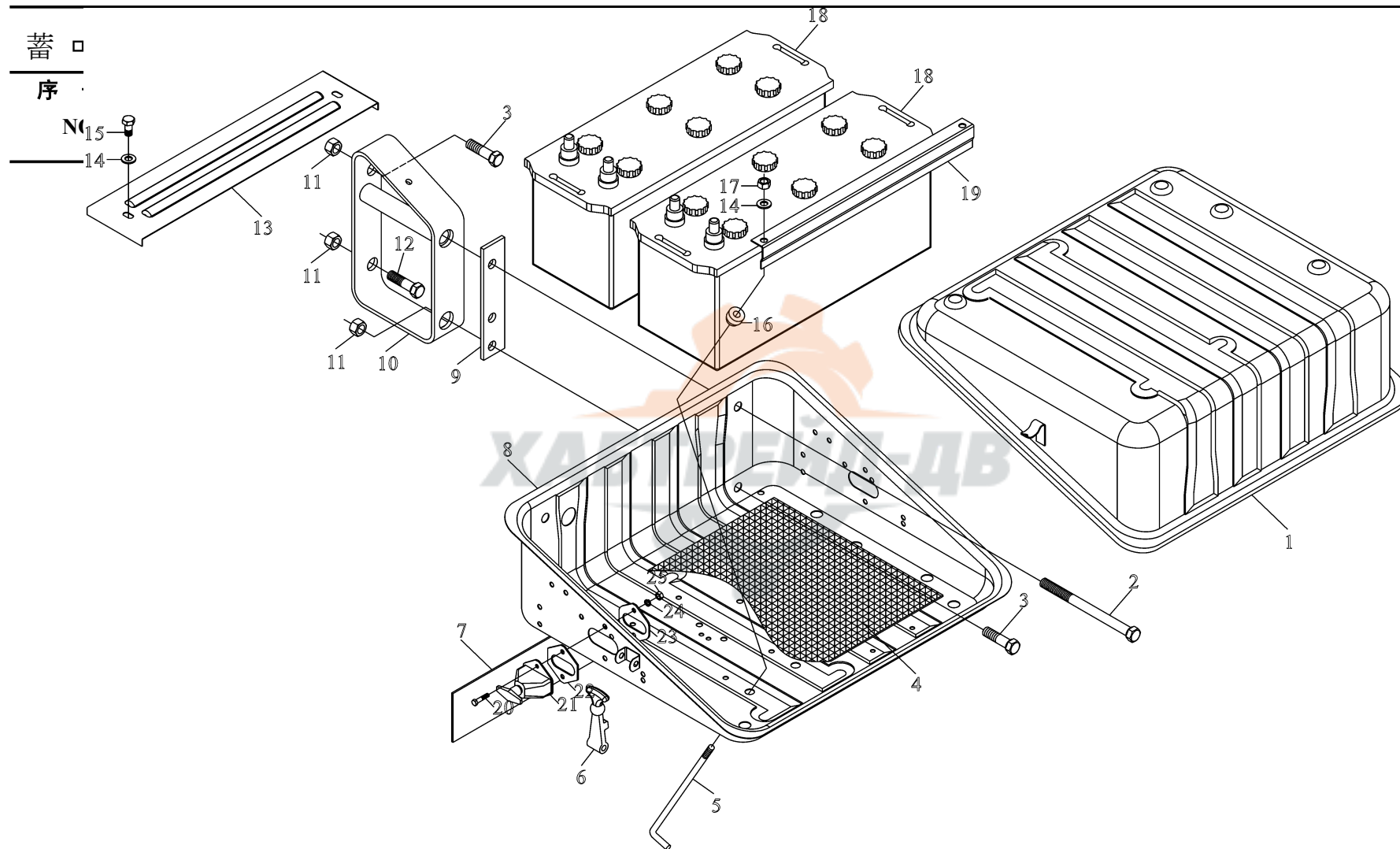

1	99100760008	蓄□ 池箱盖□ 成	Cover	1		
2	Q150B16200	六角□ 螺栓	Hex screw	2		
3	Q151B1645	六角□ 螺栓	Hex screw	3		
4	99100760084	橡胶□ 板	Rubber pad	1		
5	AZ9100760143	□ 固拉杆	Draw bar	4		
6	99100760021	拉 □	Hook	2		
7	99100760066	隔 板	Plate	1		
8	99100760227	蓄□ 池箱体□ 成	Battery box	1		
9	AZ9100760001	□ 板 □	Pad	1		
10	99114760004	蓄□ 池箱支架	Bracket	2		
11	Q33216	自□ 螺母	Locking nut	4		
12	Q150B1640	六角□ 螺栓	Hex screw	2		
13	99100760011	盖	Cover	1		
14	Q40008	小□ 圈	Washer	4		
15	A8×16D07513	切槽六角螺□	Slit screw	2		
16	682 110021	□ 冲□	Cushion pad	4		
17	Q33408	自□ 螺母	Locking nut	4		
18	99100760064	135 安 - □ □ 准蓄□ 池	Standard battery	2		
	99100760065		Standard battery	2		
19	79200760024	165 安 - □ □ 准蓄□ 池	Bracket	2		
20	Q150B0835		Hex screw	2		
21	99100760100	□ □ 支架	Switch battery	1		
22	99100760099	六角□ 螺栓	Seal washer	1		
23	DZ9100766001	蓄□ 池□ □ □	Insulating cushion	1		

□ 束 WIRING

□ 束 W

序号

NO

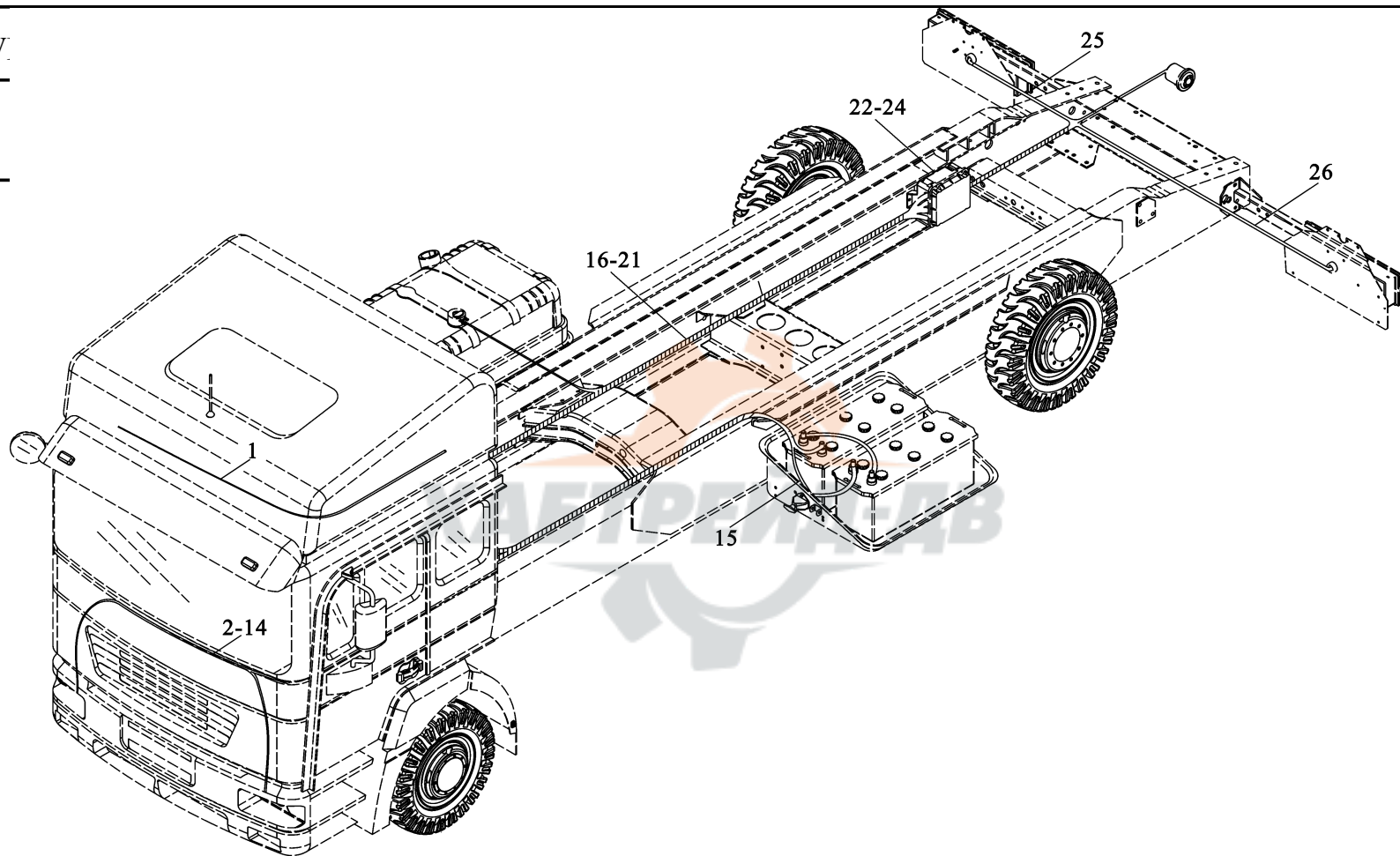

1	81.25426.6425	高顶驾驶室线束	High roof cab wiring	1	6×4	用于高顶 To high roof
2	81.25428.6604	驾驶室电线束	Cab wiring	1	4×2	右置车 to right
	81.25428.6605	驾驶室电线束	Cab wiring	1		
3	81.25416.6739	扬声器电线束	Loud hailer wiring	1		
4	81.25417.6647	收放机（12V）电线束	Radio wiring	1		
	81.25417.6648		Radio wiring	1		
5	81.25426.6910	收放机电线束	Cigarette wiring	1		
6	81.25416.6912	点烟器电线束	Cigarette box light wiring	1		右置车 to right
7	81.25426.6912	烟灰盒照明电线束	Right front wiring	1		
	81.25416.6734	右前部电线束	Right front wiring	1		
8	81.25426.6193	右前部电线束	Left front wiring	1		
9	81.25426.6123	左前部电线束	Left door wiring	1		右置车 to right
	81.25426.6140	左车门电线束	Right door wiring	1		
10	81.25416.6776	右车门电线束	Step light wiring	2		
11	DZ91.0077.610	左右车门踏步灯电线束	ABS cab wiring	1		豪华型 Luxury
12	2	ABS驾驶室电线束	Left roof wiring	1		
	81.25428.6085	驾驶室左顶蓬电线束	Left roof wiring	1		豪华型 Luxury
	DZ91.0077.608	驾驶室左顶蓬电线束				
13	5		Right roof wiring	1		
14		驾驶室右顶蓬电线束	Chassis wiring	1		基本型 Standard
15	81.25416.6388	ABS挂车底盘电线束	Starter wiring	1		西安正昌
16	DZ9100776005	起动机电线束	Chassis wiring I	1		豪华型 Luxury
	DZ9100776001	底盘线束（一）	Chassis wiring I	1		
	DZ9100776012	底盘线束（一）	Chassis wiring I	1		
	DZ9100776002	底盘线束（一）	Chassis wiring I	1		基本型 Standard

□ 束 WIRING

□ 束 W

序号

NO

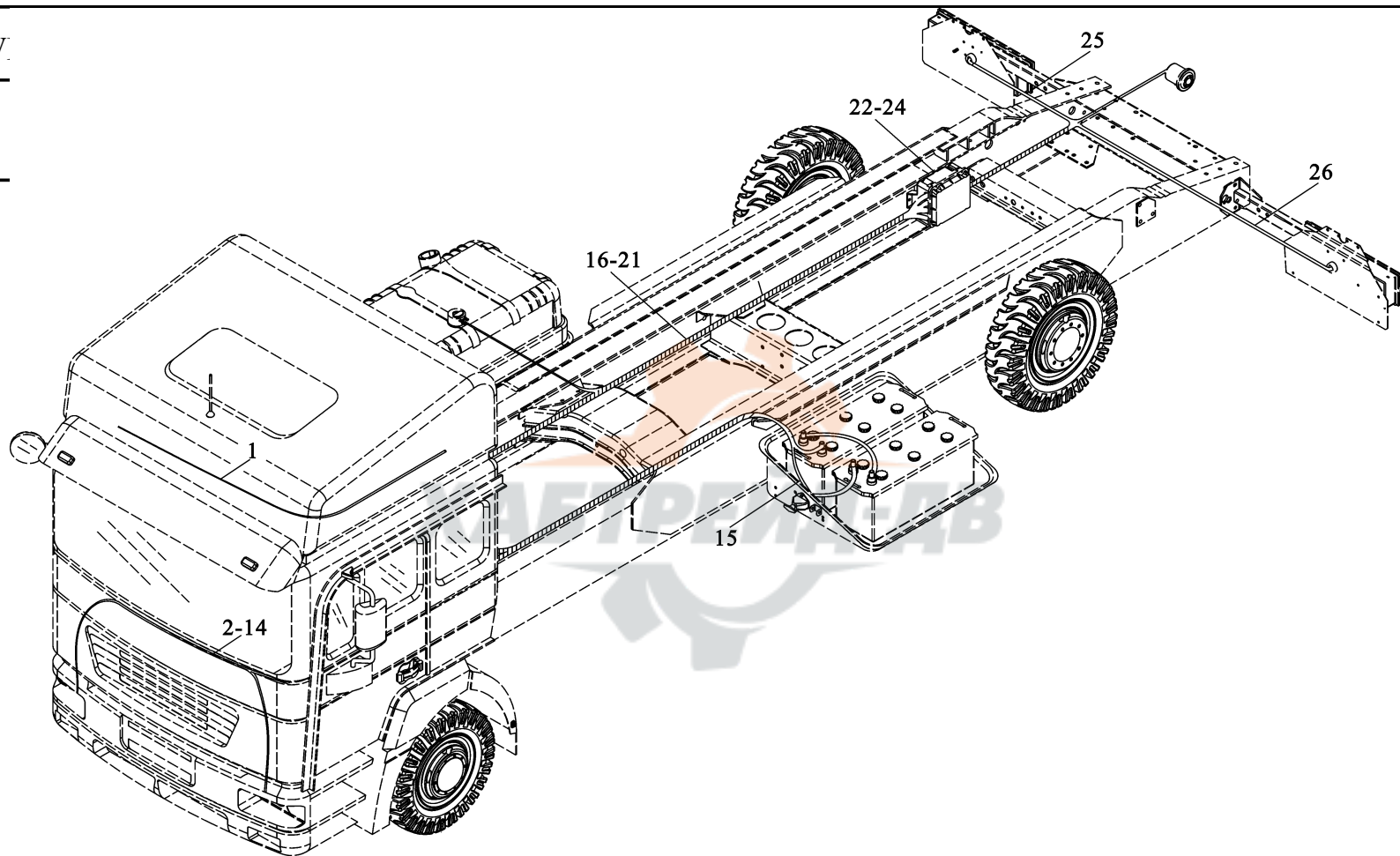

17	DZ9100776003	底盘线束 (二)	Chassis wiring II	1		潍柴发动机
	DZ9100776030	底盘线束 (二)	Chassis wiring II	1		上柴发动机
	DZ9100776033	底盘线束 (二)	Chassis wiring II	1		玉柴发动机
	DZ9100776073	底盘线束 (二)	Chassis wiring II	1		ZF 变速箱
	DZ9100776043	底盘线束 (二)	Chassis wiring II	1	8×4	
18	89100770088	轴间差速和爬行档线束	Wiring harness axle differential lock and crawl speed	1	6×4	
	89100770076	轮间差速锁线束	Differential lock wiring	1	4×2	
19	DZ9100770705	ABS线束	ABS wiring	1	4×2	西安正昌
	DZ9100770706	ABS线束	ABS wiring	1	6×4	西安正昌
20	DZ9100770502	ABS挂车底盘电线束	ABS trailer chassis wiring	1		
21	DZ9100770022	ABS螺旋型柔性电缆总成	Cable	1		WABCD 型号: 446 008 2300
	DZ9100770032	成	Cable	1		
22	79100770391	ABS螺旋型柔性电缆总成	Electric box	1		JAGER 。 POWAY : 641001
23	79100770392	成	Junction box body	1		
24	79100770394	配电盒	Junction box cover	1		
25	AZ9100773022	分线箱体	Right rear light wiring	1	6×4	
	DZ9100773024	分线盒盖	Right rear light wiring	1	4×2	
26	AZ9100773023	右组合后灯电线束	Left rear light wiring	1	6×4	
	DZ910077.025	右组合后灯电线束 左组合后灯电线束 左组合后灯电线束	Left rear light wiring	1	4×2	

□ □ 室 □ □ 束 □ ( □ 表 台 内 ) CENTRAL ELECTRICAL SYSTEM

□ □  
 序 号  
 NC

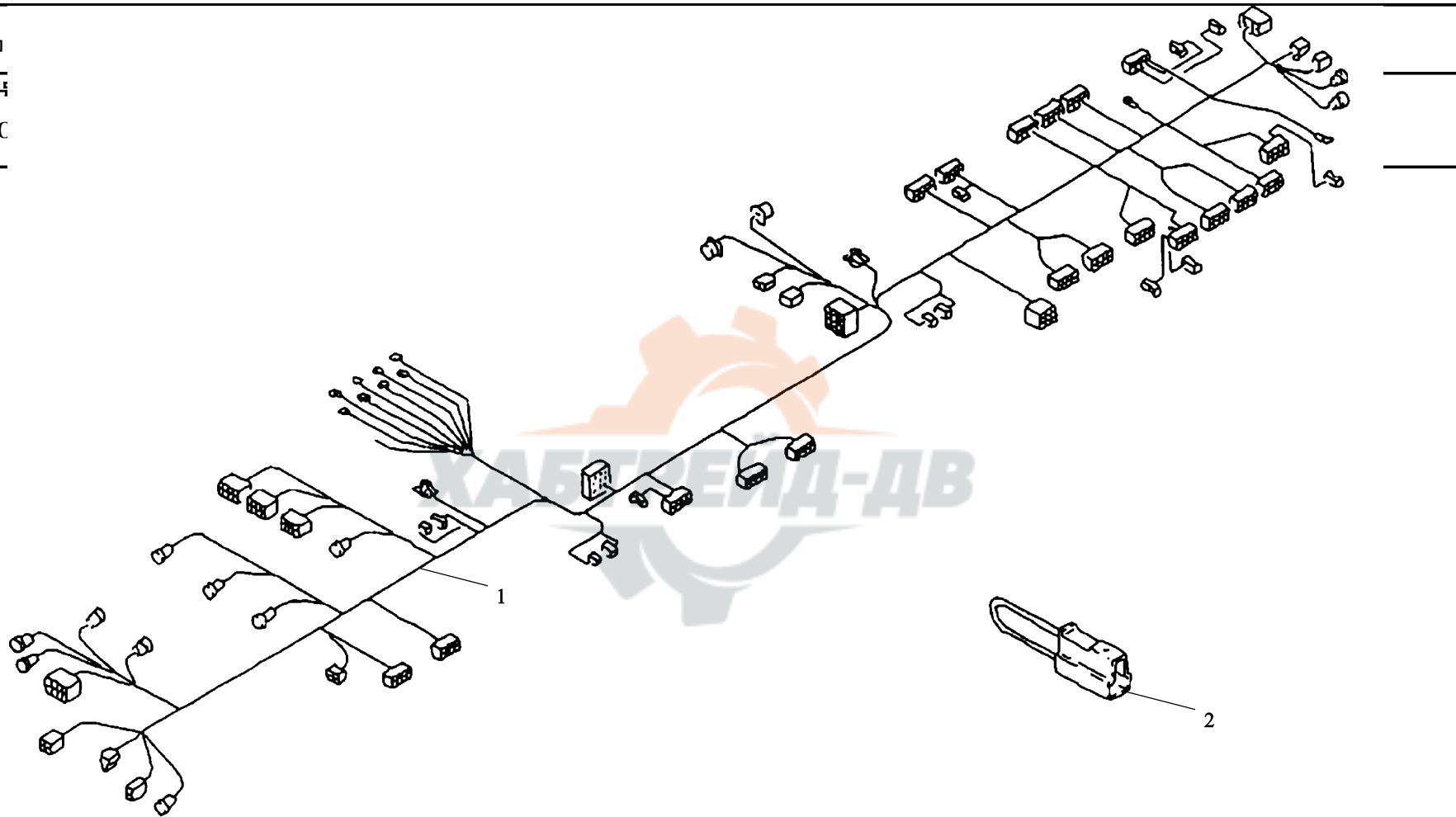



1	81.25428.6604	驾驶室电线束	Central electrical system	1		
	81.25428.6605	驾驶室电线束	Central electrical system	1		
2	81.25408.6059	连接线	Connecting line	1		右置车 to right



# 高顶驾驶室电线束（仪表台内） HIGH ROOF CAB WIRING

高顶驾

序号
NO

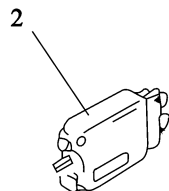

注  
ark

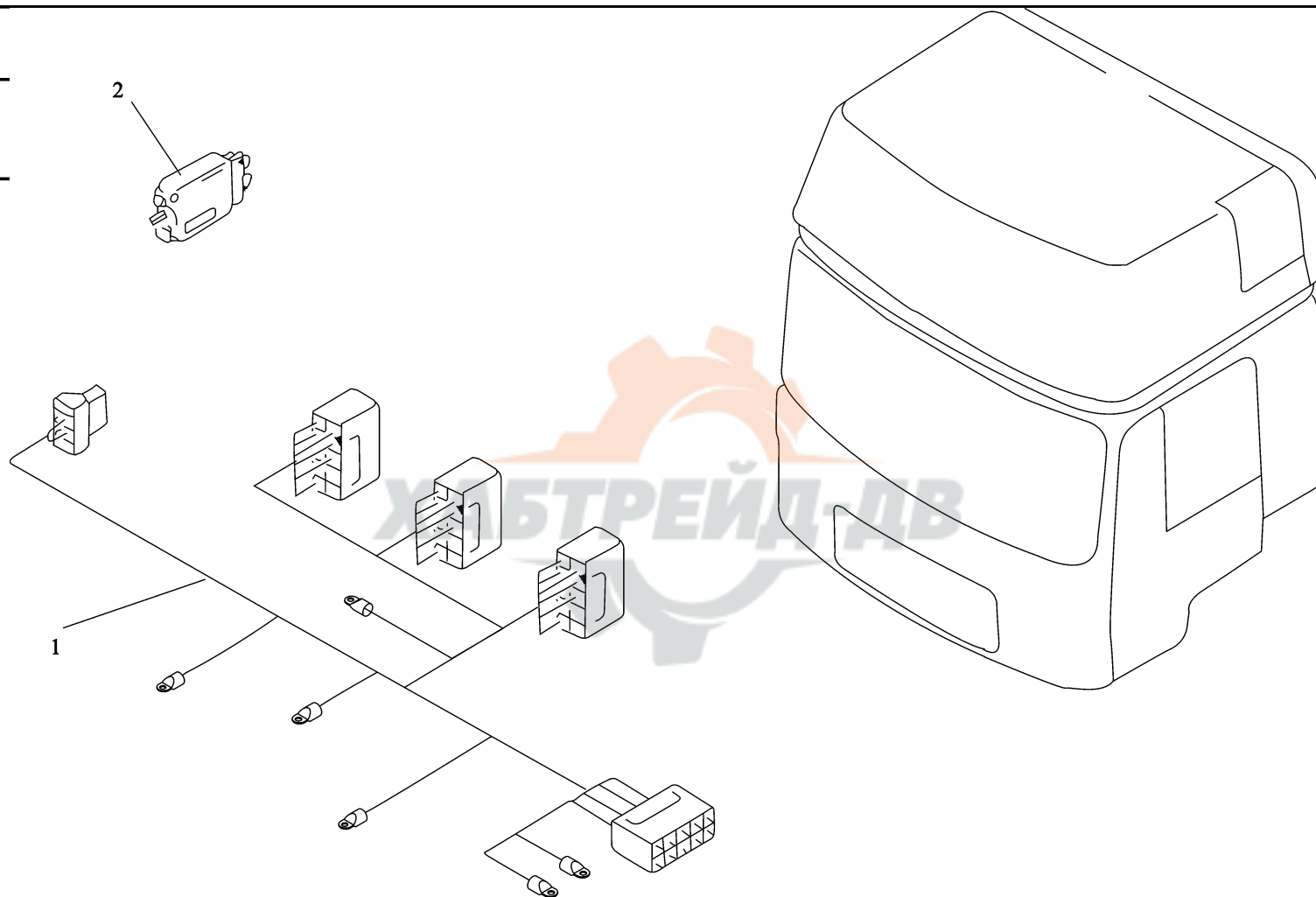

1	81.25426.6425	高顶驾驶室电线束	High roof cab wiring	1		(仪表台内)
	81.25426.6426	高顶驾驶室电线束	High roof cab wiring	1		右置车 to right
2	81.25436.0065	红色熔断丝	Red fuse	1		10A



# 电动玻璃升降器线束 WINDOW LIFTER WIRING

电动  
序号  
NO

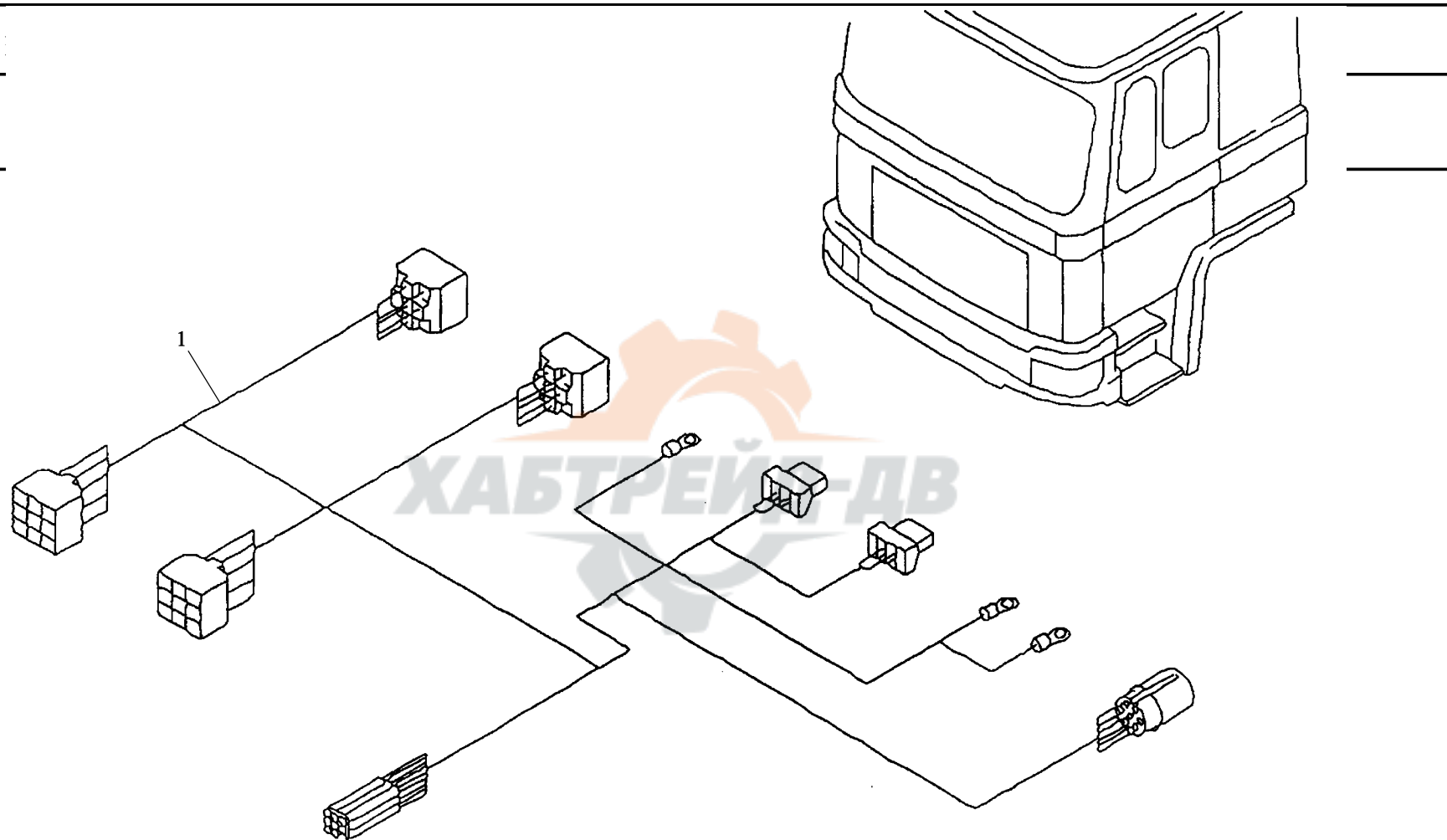

1	81.25426.6118	电动玻璃升降器驾驶室线束总成	Window lifter wiring	1		
---	---------------	----------------	----------------------	---	--	--



顶蓬电线束 ROOF WIRING

顶蓬电线束 ROOF W

序号 NO	件号 Part.No	I
----------	---------------	---

型 type	备注 Remark
-----------	--------------

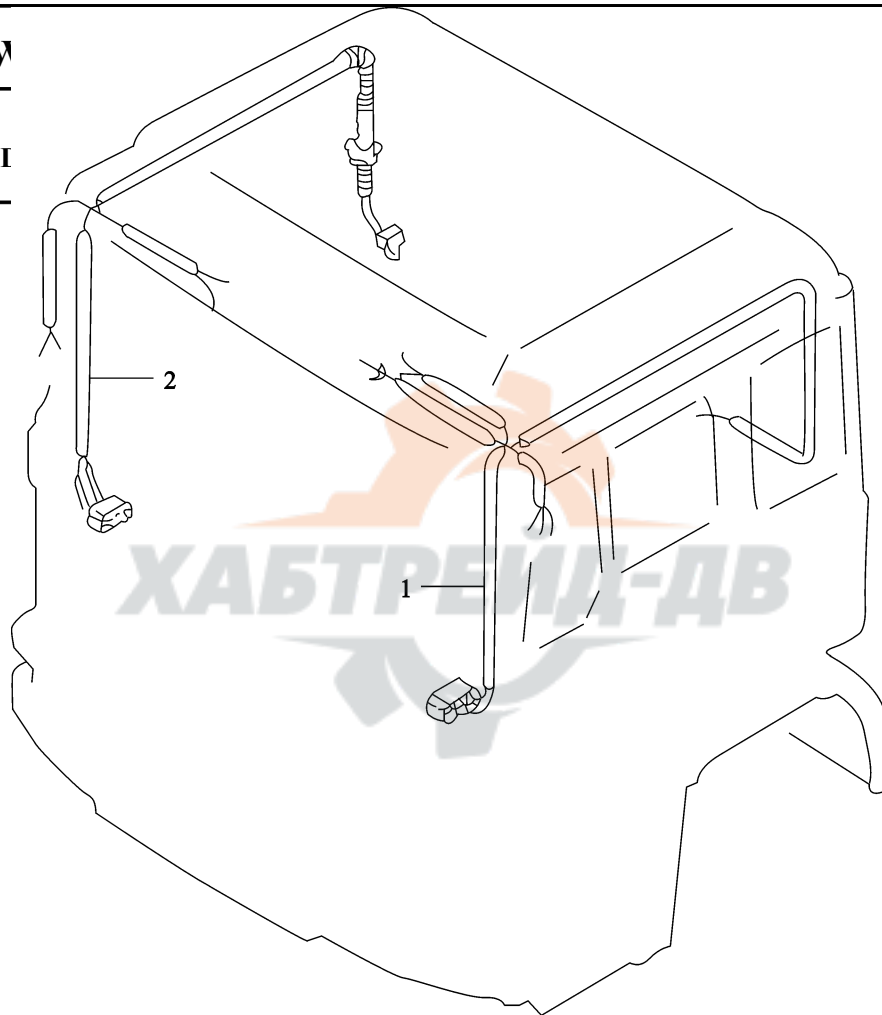

1	81.25428.6085	驾驶室左顶篷电线束	Left roof wiring	1		高顶 high roof
	81.25428.6087	驾驶室左顶篷电线束	Left roof wiring	1		右置车 to right
	DZ91.0077.608	左顶篷电线束	Left roof wiring	1		
	5	驾驶室左顶篷电线束	Left roof wiring	1		基本型驾驶室 standard cab
2	81.25428.6081	驾驶室右顶篷电线束	Right roof wiring	1		
	81.25416.6388					平顶 flat roof



□ 速 里 程 表、 行 □ □ □ □ □ CABLE

□ 速 里 程 表

序 号	件
NO	Part

备 注  
Remark

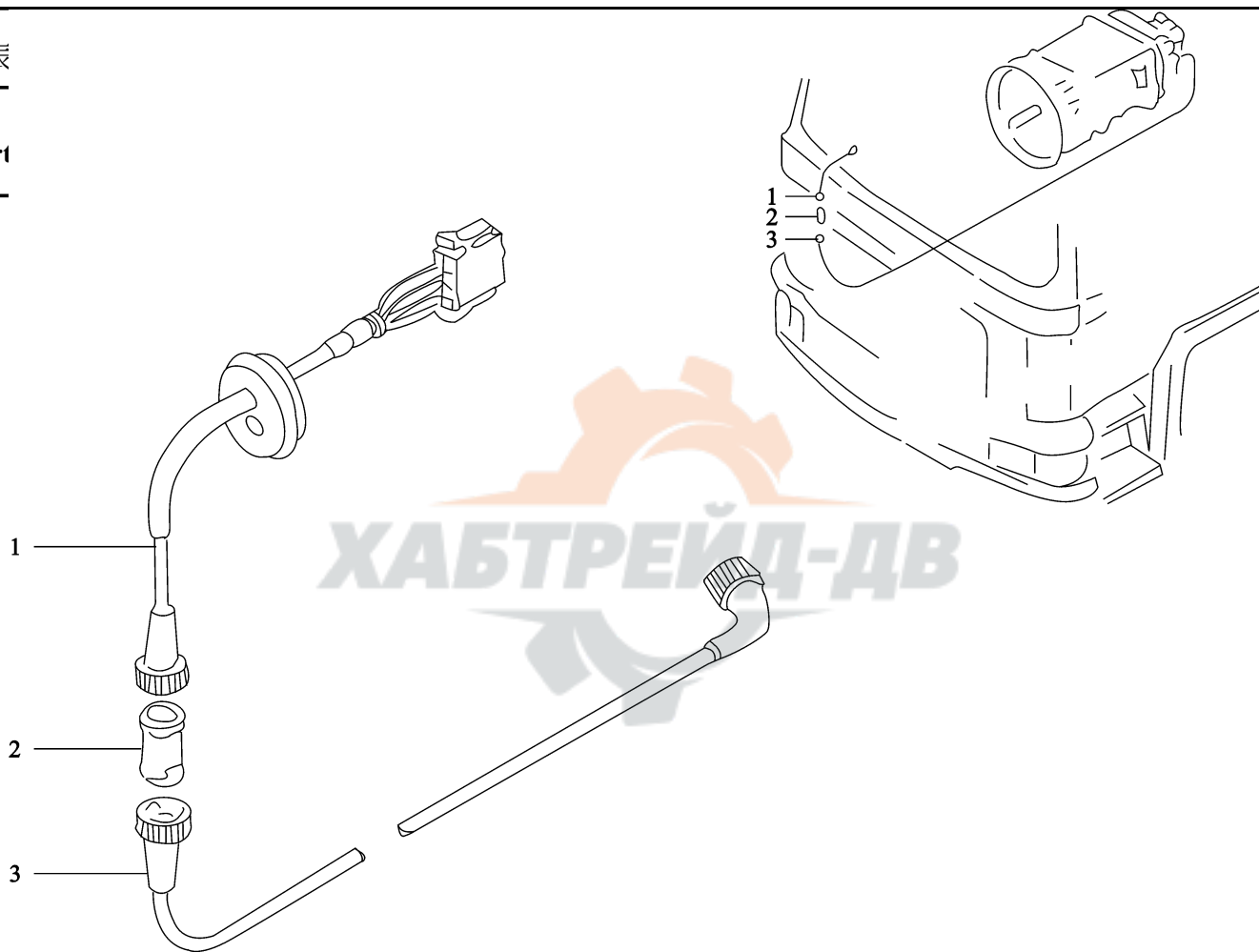



1	81.27111.0142	行驶记录仪驾驶室电缆	Electronic odometer cab cable	1		(2800mm)
2	81.27131.0007	行驶记录仪电缆连接器	Connecting device	1		( 5100mm )
3	81.27111.0144	行驶记录仪底盘电缆	Chassis cable	1		



# 37 孔诊断接口电线束（仪表台内）

# LOOM DIAGNOSTIC SYSTEM

## 37 孔诊断接口 E

序号 NO	件号 Part.No
----------	---------------

备注 Remark
--------------

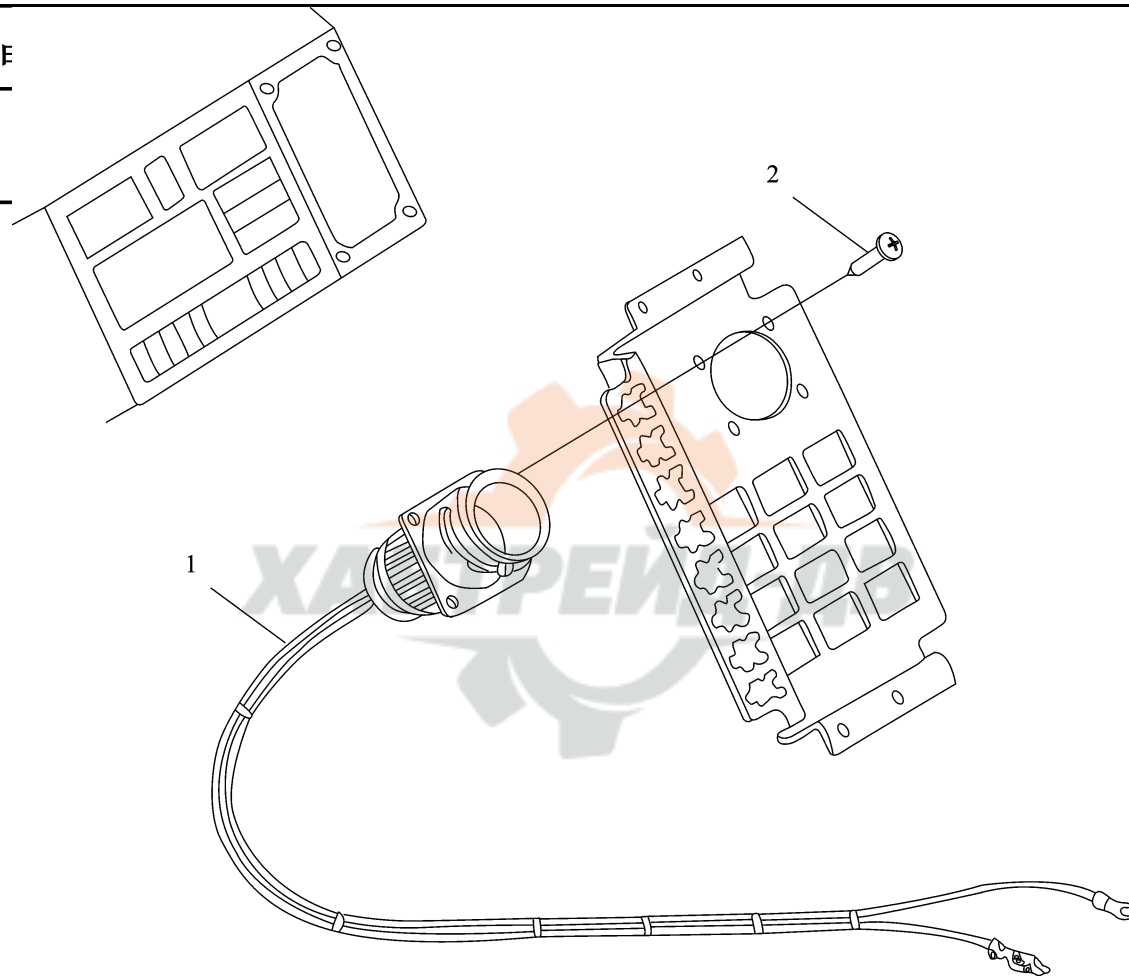

1	81.25416.6943	37孔诊断接口电线束	Loom diagnostic system	1		
	81.25417.6060	37孔诊断接口电线束	Loom diagnostic system	1		
2	06.07159.0014	十字槽盘头自攻螺钉	screw	2		右置车 to right



# 点烟器、烟灰盒照明电线束（在仪表台内） LOOMS IN CAB CENTER PART

点烟器

序号

NO

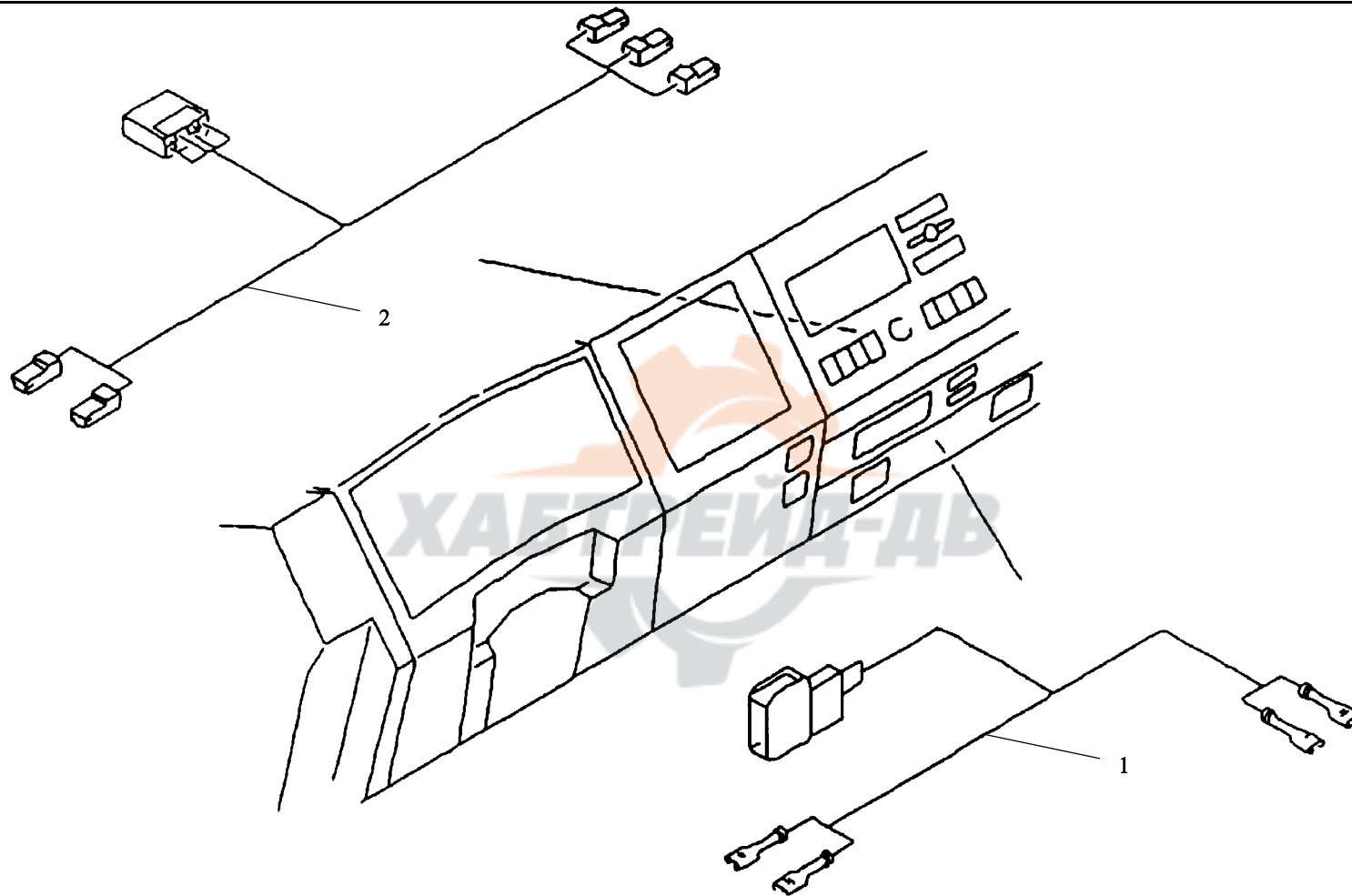

1	81.25426.6910	点烟器电线束	Cigarette wiring	1		
2	81.25416.6912	烟灰盒照明电线束	Cigarette box wiring	1		



# 恒温空调电线束 LOOMS FOR AIR CONDITIONING

恒  
序  
1

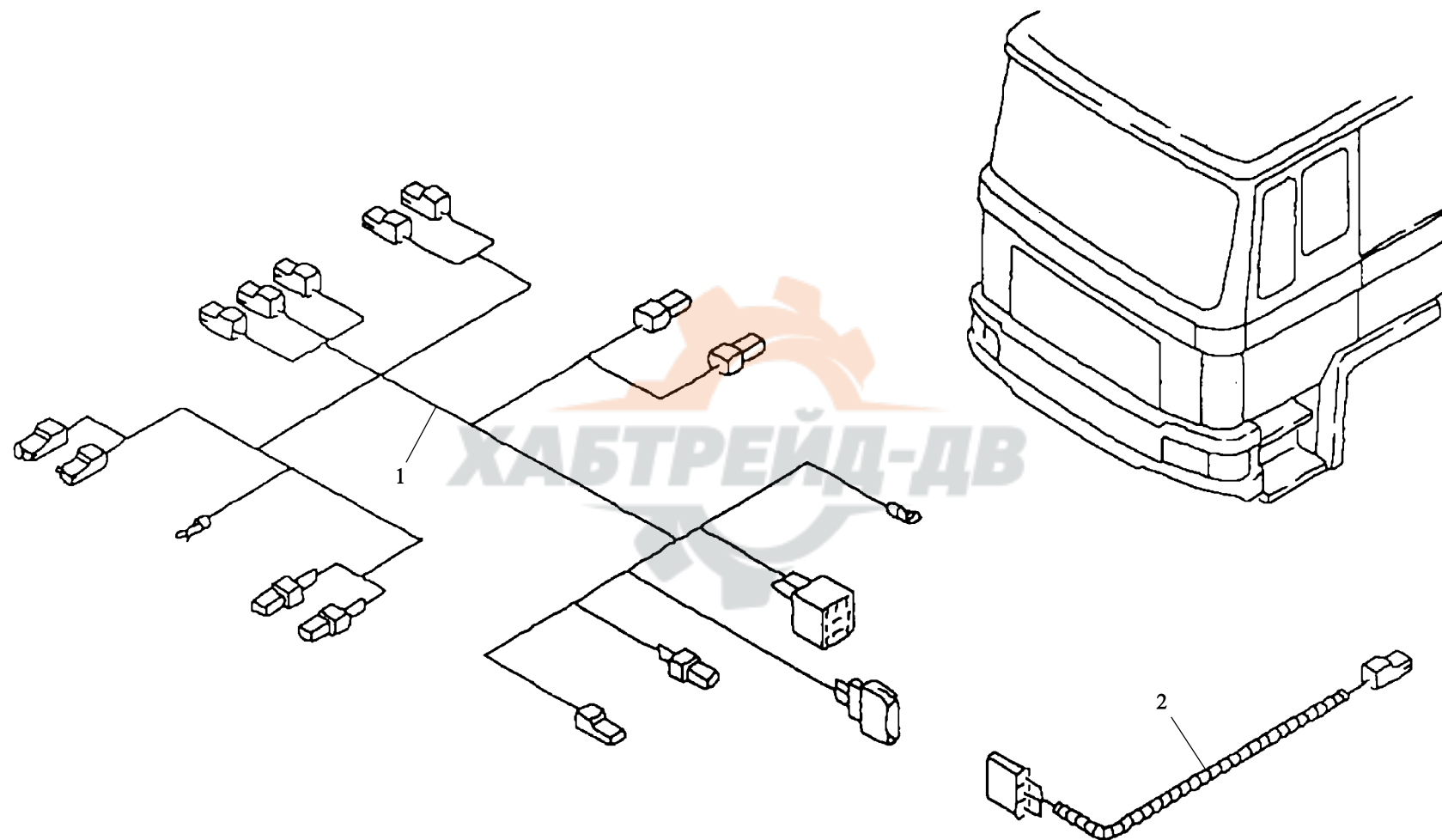

1	81.25419.6917	空调驾驶室线束总成 (仪表台内)	Air conditioning cab wiring	1		
2	81.25418.6626	空调驾驶室线束	Air conditioning cab wiring	1		右置车 to right
	81.25427.6339	压缩机电磁开关电线束	Compressor magnetic switch wiring	1		
	81.25427.6340	压缩机电磁开关电线束	Compressor magnetic switch wiring	1		右置车 to right



左、右前部分 □ □ 束 LOOMS ON CAB OUTER

左、右前部

序号 NO	件 Pa
----------	---------

备注  
Remark

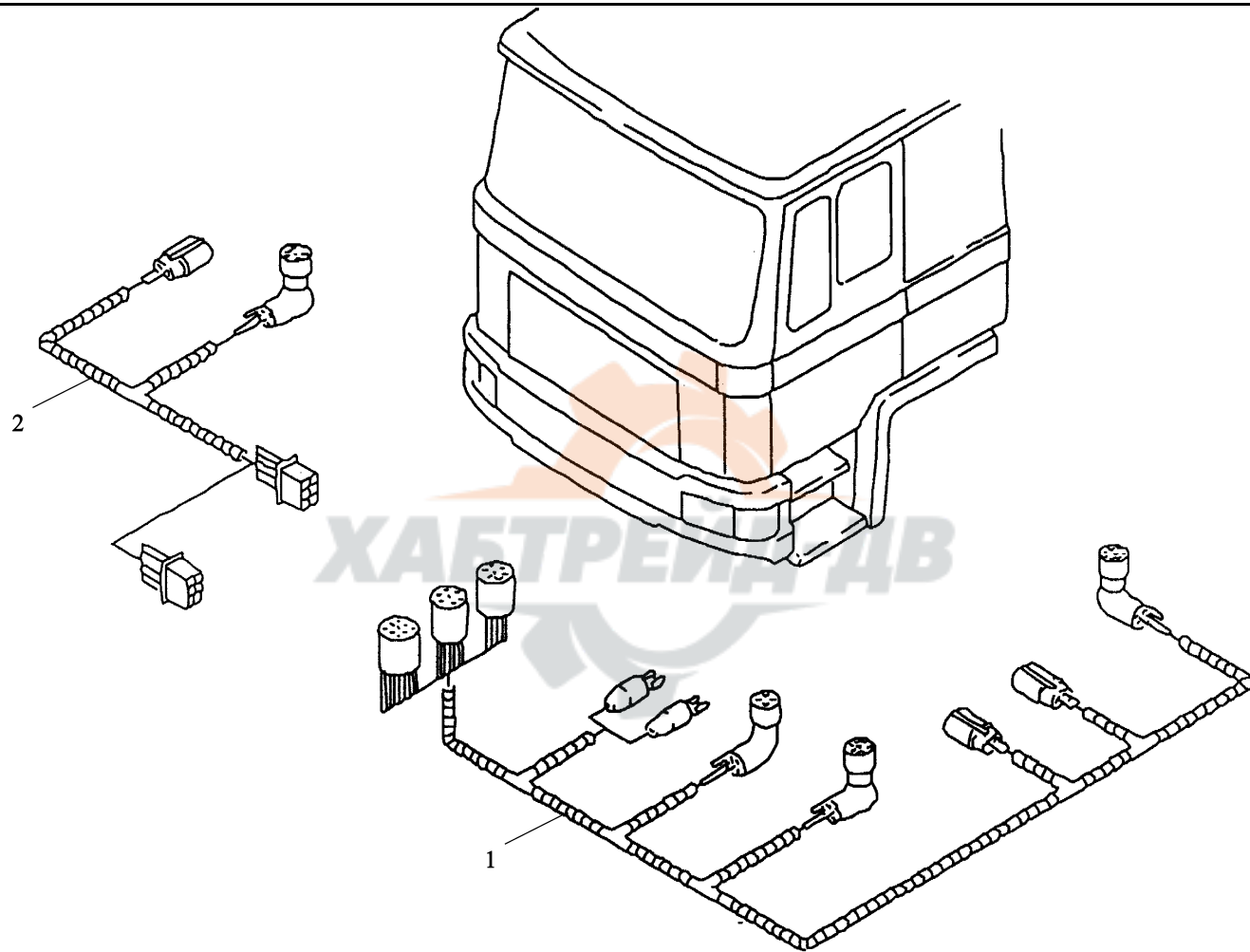



1	81.25426.6193	左前部分电线束	Left front wiring	1		
	81.25416.6907	左前部分电线束	Left front wiring	1		
2	81.25416.6734	右前部分电线束	Right front wiring	1		右置车 to right



# 电动玻璃升降器电器装置    PUSH KEY FOR ELECTRIC WINDOW LIFTER

## 电动玻璃升降

序号 NO	件号 Part.No
----------	---------------

备注 Remark
--------------

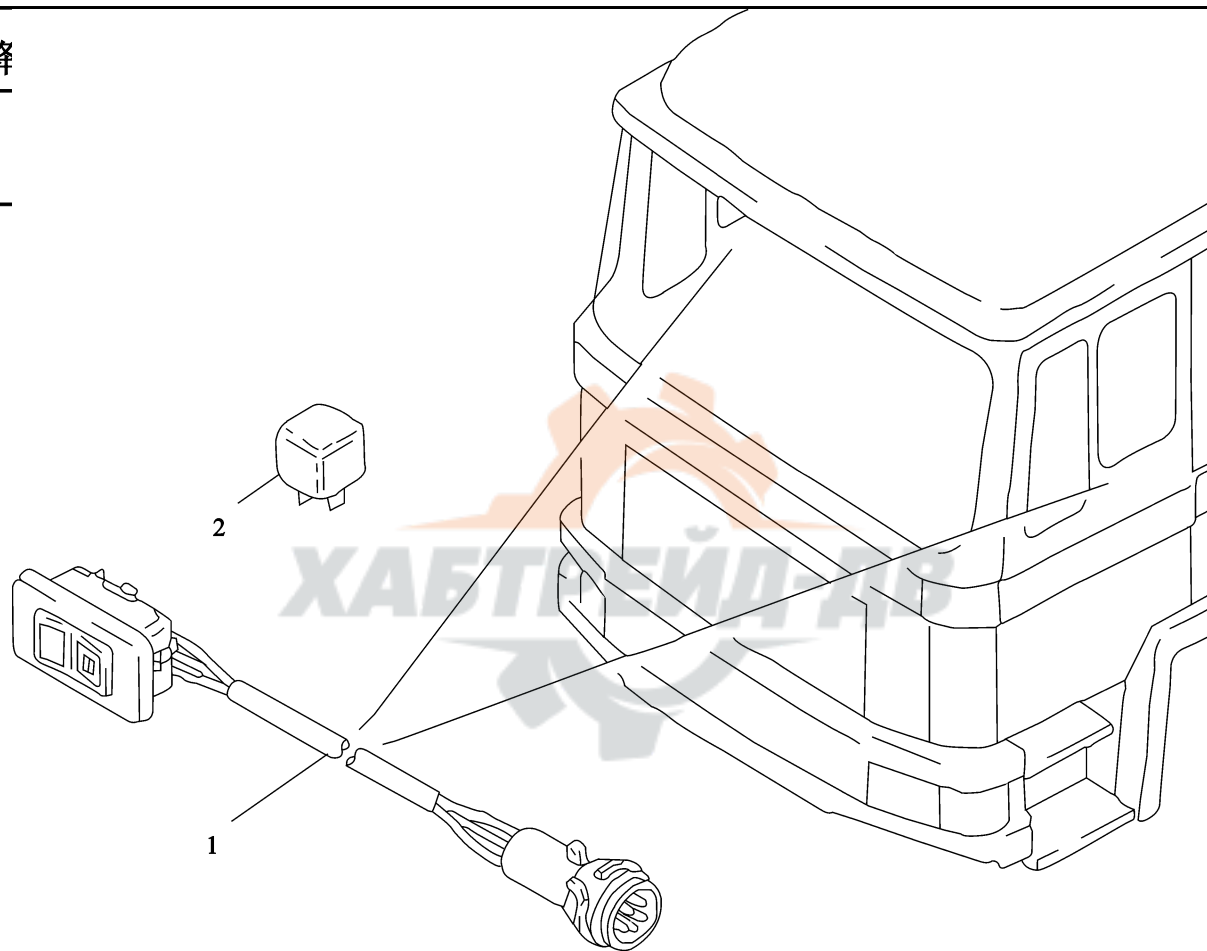

1	81.25503.0223	电动玻璃升降器翘板开关	Electric window lifter switch	3		
2	81.25902.0460	继电器（转换式）	Relay	4		

