

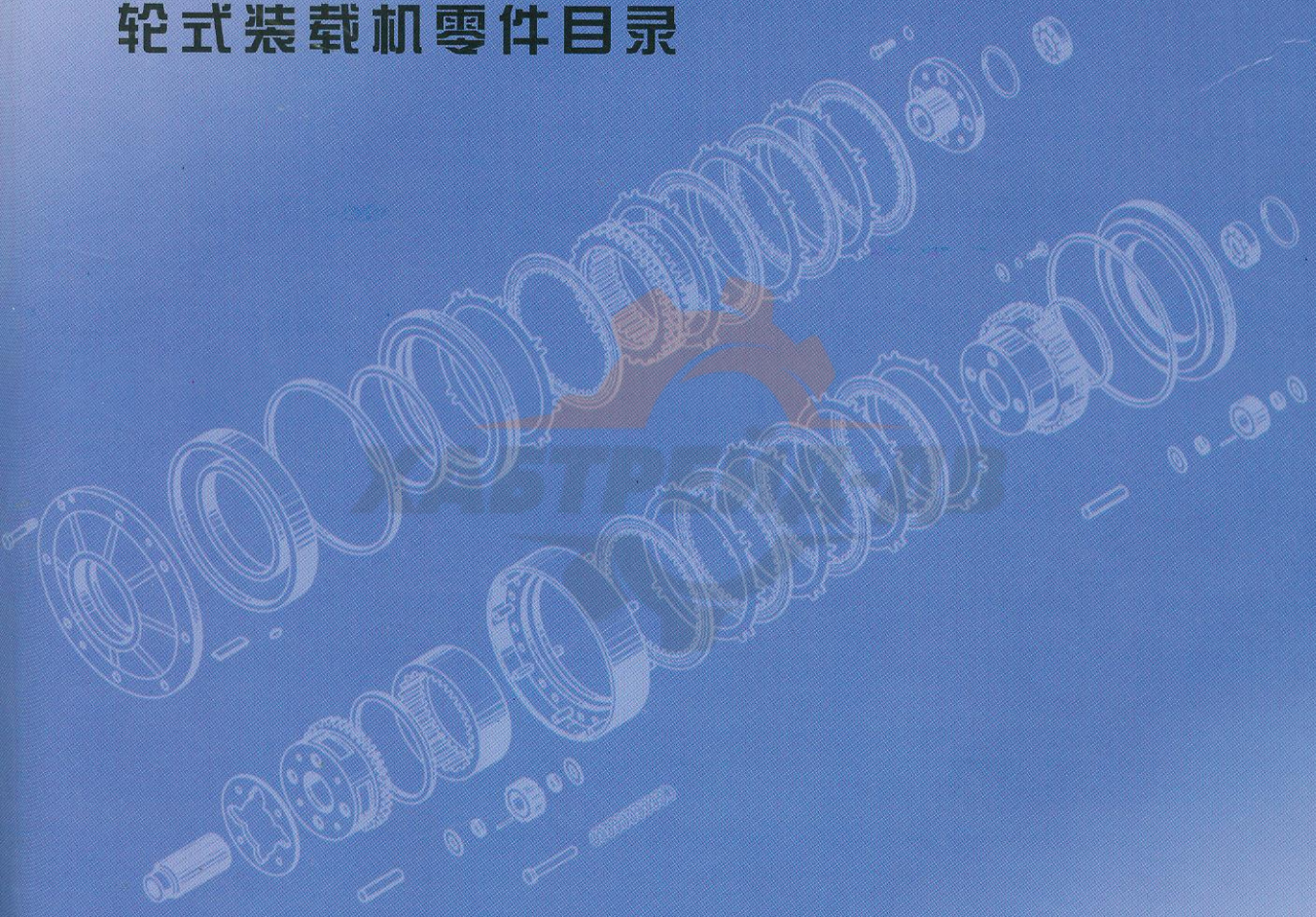

# ZL50G

WHEEL LOADER  
PART SLIST

轮式装载机零件目录



徐州工程机械科技股份有限公司  
XUZHOU CONSTRUCTION SCIENCE MACHINERY CO.,LTD



# 目 录

## Contents

1. 动力系统 Power System .....	1
2. 发动机系统 Engine System .....	4
3. 油门操纵阀 Accelerator Control Valve .....	7
4. 柴油箱总成 Fuel Tank Assy .....	9
5. 前传动轴 Front Drive Shaft .....	11
6. 后传动轴总成 Rear Drive Shaft Assy .....	13
7. 轮辋总成 Rim Assy .....	15
8. 主减速器总成 Main Transmission Parts .....	17
9. 轮边减速总成 Planetary Reductor .....	20
10. 变速箱系统 Transmission System .....	22
11. 液力变矩器 Torque Converter .....	24
12. 变速箱(一) Transmission(1) .....	27
13. 变速箱(二) Transmission(2) .....	29
14. 变速箱(三) Transmission(3) .....	31
15. 变速箱(四) Transmission(4) .....	34
16. 变速箱(五) Transmission(5) .....	36
17. 变速箱(六) Transmission(6) .....	38
18. 变速箱(七) Transmission(7) .....	40
19. 变速箱(八) Transmission(8) .....	42
20. 滤清器 Oil Filter .....	44
21. 操纵系统(一) Control System(1) .....	46
操纵系统(二) Control System(2) .....	47
22. 工作装置 Working Device .....	50
23. 前车架 Front Chassis .....	52
24. 后车架总成 Rear Chassis Group .....	55

25.左右台架 Left Right Platform .....	58
26.电瓶箱 Battery Box .....	60
27.车架注油管总成 Grease Pipe Assem .....	62
28.工作液压系统 Working Hydraulic System .....	64
29.转向液压系统 Steering Hydraulic System .....	68
30.先导液压系统 Pilot Hydraulic System .....	71
31.液压油箱 Hydraulic Tank .....	74
32.全液压转向器 Hydraulic Steering Control Units .....	76
33.转斗油缸 Tilt Cylinder .....	78
34.左右动臂油缸 Left Right Liftarm Cylinder .....	80
35.左右转向油缸 Left Right Steering Cylinder .....	82
36.双联齿轮泵 Twin-Gear Pump .....	84
37.齿轮泵 Gear Pump .....	87
38.先导阀 Pilot Valve .....	89
39.多路阀 Multi-Way Valve .....	91
40.流量放大阀 Flow-Amplifying Valve .....	93
41.限位阀 Limiting Valve .....	96
42.选择阀 Selective Valve .....	98
43.制动系统 Brake System .....	100
44.手制动 Hand Brake .....	103
45.制动控制器 Brake Controller .....	105
46.手制动器总成 Parking Braker Assy .....	107
47.盘式制动器 Disk Brake .....	109
48.空气加力泵组 Air Master Unit .....	111
49.切断气缸 Break Air Cylinder .....	113
制动气缸 Brake Air Cylinder .....	113
50.驾驶室 Cab .....	115
51.电气系统 Electrical System .....	117
52.机罩 Engine Hood .....	120
53.空调系统 Air Conditioner .....	122



# 1. 动力系统 Power System

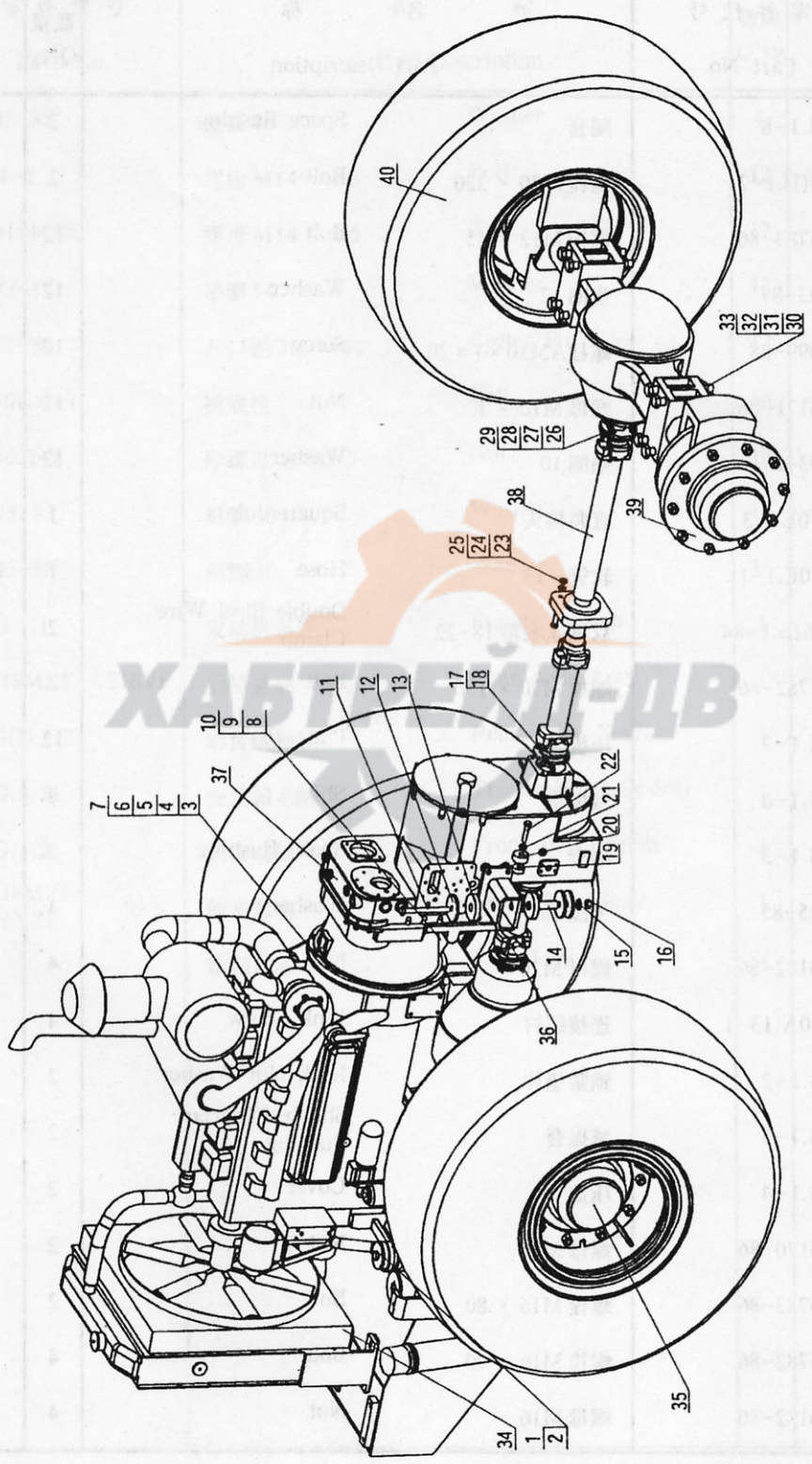



## 1.动力系统 Power System

序号 Sr. No.	零件代号 Part No.	名称 Part Description	数量 Q'ty	备注 Remark
1	Z5G.1-8	隔套 Space Bushing	2	
2	Z5G(I).1-2	螺栓 M20 × 220 Bolt	2	
3	GB5783-86	螺栓 M12 × 45 Bolt	12	
4	GB93-87	垫圈 12 Washer	12	
5	GB899-88	螺柱 AM10 × 1 × 20 Screw	12	
6	GB6171-86	螺母 M10 × 1 Nut	12	
7	GB93-87	垫圈 10 Washer	12	
8	ZL50E.1.3	直角接头 Square Joint	1	胶管 B(8)-F 13
9	ZL50E.1-1	软管 F 13 Hose	1	
10	JB3616.1-84	双钢丝喉箍 18-22 Double Steel Wire Clamp	2	
11	GB5782-86	螺栓 M20 × 150 Bolt	2	
12	Z5G.1-7	压板 Plate/Par	12	
13	Z5G.1-6	减振垫 Shim	8	
14	Z5G.1-3	隔套 Space Bushing	2	
15	GB95-85	垫圈 20 Washer	4	
16	GB6182-86	螺母 M20 Nut	4	
17	ZL40A.13-1	连接螺钉 Link Screw	4	
18	Z5G.1-2	锁紧垫片 Lock Nut Washer	2	
19	Z5G.1-5	减振套 Shock-Absorber Bushing	2	
20	Z5G.1-4	压盖 Cover	2	
21	GB6170-86	螺母 M16 Nut	2	
22	GB5783-86	螺栓 M16 × 80 Bolt	2	
23	GB5782-86	螺栓 M16 × 90 Bolt	4	
24	GB6182-86	螺母 M16 Nut	4	



# 1.动力系统 Power System

序号 Sr. No.	零件代号 Part No.	名 称 Part Description	数量 Q'ty	备 注 Remark
25	GB95-85	垫圈 16                      Washer	4	
26	Z3.4-2	螺栓 M14 × 1.5              Bolt	12	
27	GB6181-86	螺母 M14 × 1.5              Nut	12	
28	GB93-87	垫圈 14                      Washer	12	
29	GB91-86	开口销 3.2 × 40              Cotter Pin	12	
30	ZL50E.6-9	桥螺栓                      Bolt	16	
31	ZL40.2-5	厚螺母                      Nut	16	
32	GB93-87	垫圈 30                      Washer	16	
33	GB95-85	垫圈 30                      Washer	16	
34	Z5G.1.1	发动机系统                      Engine System	1	
35	20/18MRF-C216VB	后桥总成                      Rear Axle Assy	1	
36	Z5G(I).1.2	后传动轴                      Rear Drive Shaft	1	
37	Z5G.1.3	变速箱系统                      Thansmission System	1	
38	Z5G.1.2	前传动轴                      Front Drive Shaft	1	
39	20/18MRF- C216NZE	前桥总成                      Front Axle Assy	1	
40		轮辋总成                      Rim Assy	4	



## 2. 发动机系统 Engine System

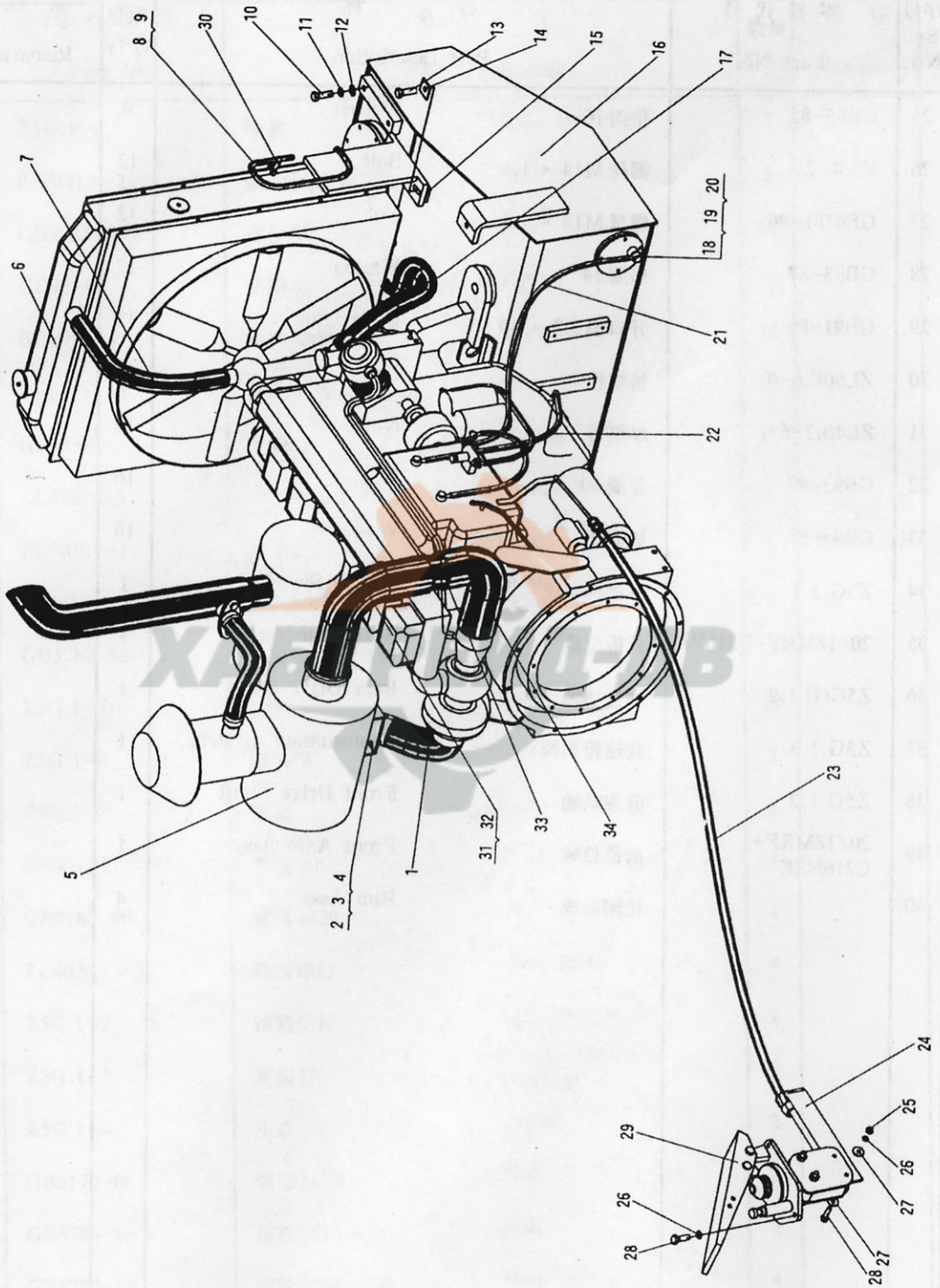



## 2. 发动机系统 Engine System

序号 Sr. No.	零件代号 Part No.	名 称 Part Description		数量 Q'ty	备注 Remark
1	WD615 67G3-31A	柴油机	Diesel Engine	1	
2	GB5781-86	螺栓 M8 × 30	Bolt	4	
3	GB93-87	垫圈 8	Washer	4	
4	GB97.1-85	垫圈 8	Washer	5	
5	K2640X-1	空气滤清器	Air Filter	1	
6	Z5G.1.1.8	水箱	Water Tank	1	
7		上水管	Upcomer	1	柴油机带 胶管
8	Z5G.1.1-4	透气管	Ventilate Pipe	1	B(8)-F 10
9	JB3616.1-84	双钢丝喉箍 15-18	Clamp	5	
10	GB5783-86	螺栓 M16 × 50	Bolt	6	
11	GB93-87	垫圈 16	Washer	6	
12	GB97.1-85	垫圈 16	Washer	6	
13	GB5783-86	螺栓 M16 × 65	Bolt	4	
14	Z5G.1.1-15	减振垫	Shock-Absorber Washer	2	
15	Z5G(I).1.1-3	板	Plate	2	
16	Z5G.1.1.3	柴油箱总成	Diesel Oil Box Assy	1	
17		下水管	Downcomer	1	柴油机带
18	85Z II.1-1	油泵接头	Oil Pump Tie-in	4	
19	JB982-77	垫圈 14	Washer	8	
20	ZL50.1.4-1S	螺栓	Bolt	4	
21	Z5G.1.1-6	进油软管	Oil inlet hose	1	胶管 B(8)-F 10
22	Z5G.1.1-7	回油软管	Return hose	1	胶管 B(8)-F 10
23		软轴	Soft Axes	1	柴油机带
24	Z5G.1.1.7A-1	软轴支架	Soft Axes Support	1	



## 2.发动机系统 Engine System

序号 Sr. No.	零件代号 Part No.	名称 Part Description	数量 Q'ty	备注 Remark
25	GB6170-86	螺母 M6 Nut	5	
26	GB93-87	垫圈 6 Washer	5	
27	GB97.1-85	垫圈 6 Washer	7	
28	GB5783-86	螺栓 M6 × 25 Bolt	5	
29	XZ1129001	油门操纵阀 Accelerator Control Valve	1	
30	85Z.08.1-1	管夹 Pipe Clamp	1	
31	Z5G.1.1-12	进气管 Air Pipe	1	
32	JB3616.1-84	双钢丝喉箍 113-120 Clamp	4	
33	Z5G.1.1-17	接管 Joint Pipe	1	
34	Z5G.1.1-16	进气管 Air Pipe	1	



### 3. 油门操纵阀 Accelerator Control Valve

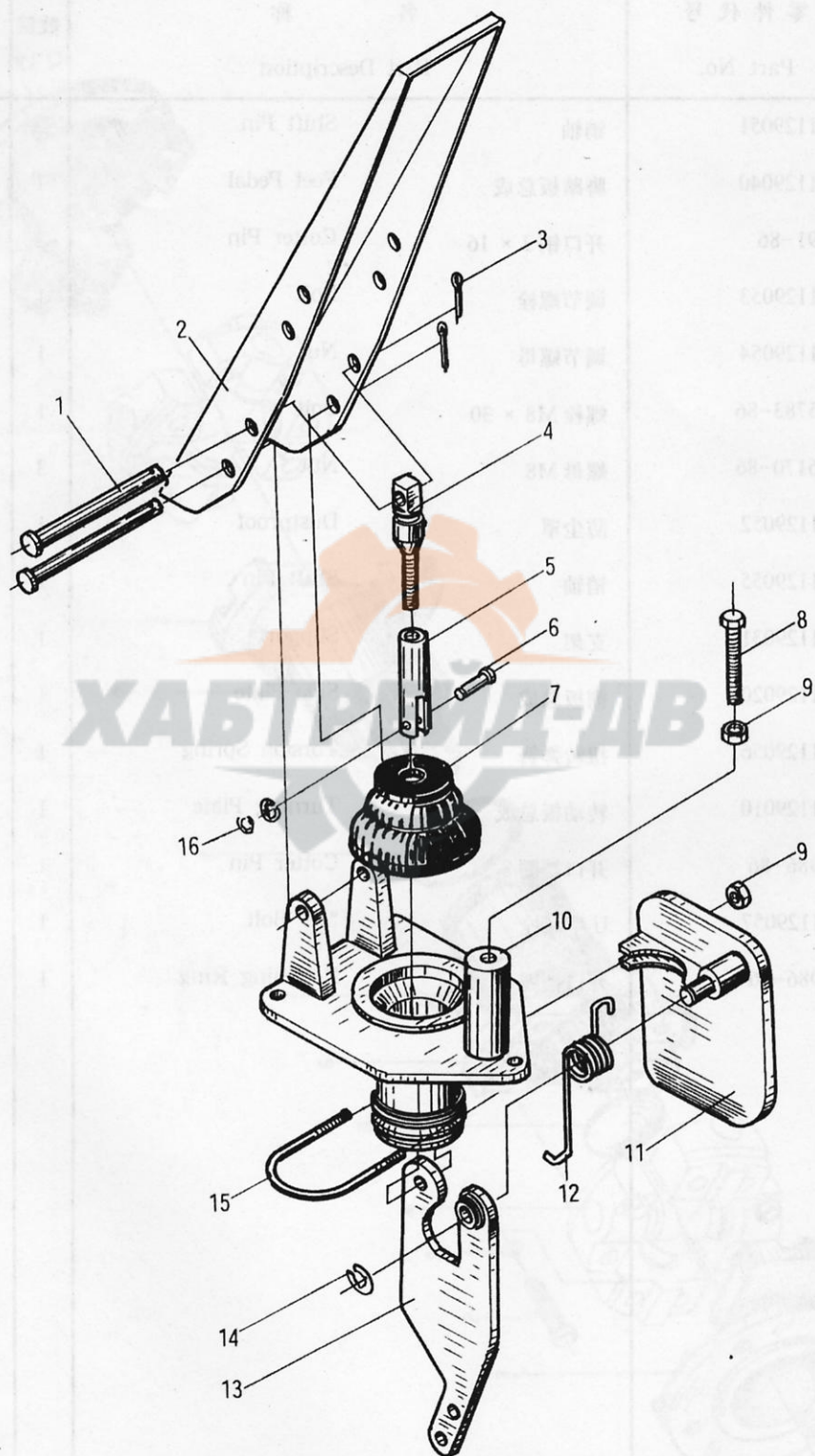



### 3.油门操纵阀 Accelerator Control Valve

序号 Sr. No.	零件代号 Part No.	名 称 Part Description	数量 Q'ty	备 注 Remark
1	XZ1129051	销轴 Shift Pin	2	
2	XZ1129040	脚踏板总成 Feet Pedal	1	
3	GB91-86	开口销 2 × 16 Cotter Pin	2	
4	XZ1129053	调节螺栓 Bolt	1	
5	XZ1129054	调节螺母 Nut	1	
6	GB5783-86	螺栓 M8 × 30 Bolt	1	
7	GB6170-86	螺母 M8 Nut	3	
8	XZ1129052	防尘罩 Dustproof	1	
9	XZ1129055	销轴 Shift Pin	1	
10	XZ1129031	支架 Support	1	
11	XZ1129020	侧板总成 Side Plate	1	
12	XZ1129056	扭转弹簧 Torsion Spring	1	
13	XZ1129010	转动板总成 Turning Plate	1	
14	GB986-86	开口挡圈 8 Cotter Pin	1	
15	XZ1129057	U型螺栓 "U" Bolt	1	
16	GB986-86	开口挡圈 4 Retaining Ring	1	



#### 4. 柴油箱总成 Fuel Tank Assy

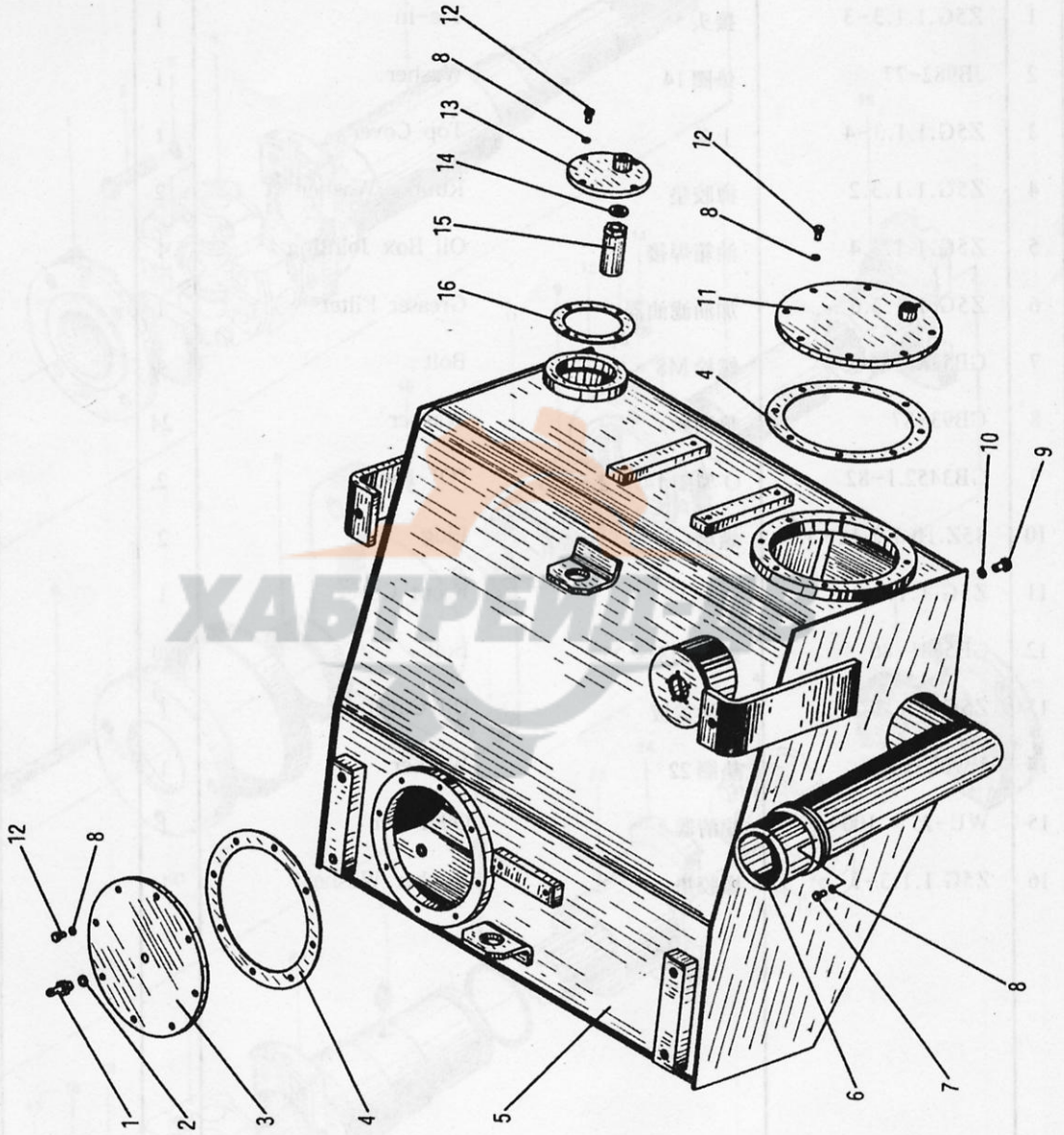



## 4. 柴油箱总成 Fuel Tank Assy

序号 Sr. No.	零件代号 Part No.	名 称 Part Description	数量 Q'ty	备 注 Remark
1	Z5G.1.1.3-3	接头 Tie-in	1	
2	JB982-77	垫圈 14 Washer	1	
3	Z5G.1.1.3-4	上盖 Top Cover	1	
4	Z5G.1.1.3.2	橡胶垫 Rubber Washer	2	
5	Z5G.1.1.3.4	油箱焊接 Oil Box Jointing	1	
6	Z5G.1.1.3.6	加油滤油器 Greaser Filter	1	
7	GB5781-86	螺栓 M8 × 16 Bolt	4	
8	GB93-87	垫圈 8 Washer	24	
9	GB3452.1-82	O 型圈 14 × 2.65 "O" Ring	2	
10	85Z.10.1.2.11-3A	螺堵 Plug	2	
11	Z5G.1.1.3.3	前盖 Front Cover	1	
12	GB5781-86	螺栓 M8 × 25 Bolt	20	
13	Z5G.1.1.3.7	出油盖板 Oil Cover	1	
14	JB982-77	垫圈 22 Washer	1	
15	WU-25 × 100-J	滤清器 Oil Filter	1	
16	Z5G.1.1.3-5	橡胶垫 Rubber Washer	1	

# 5. 前传动轴 Front Drive Shaft

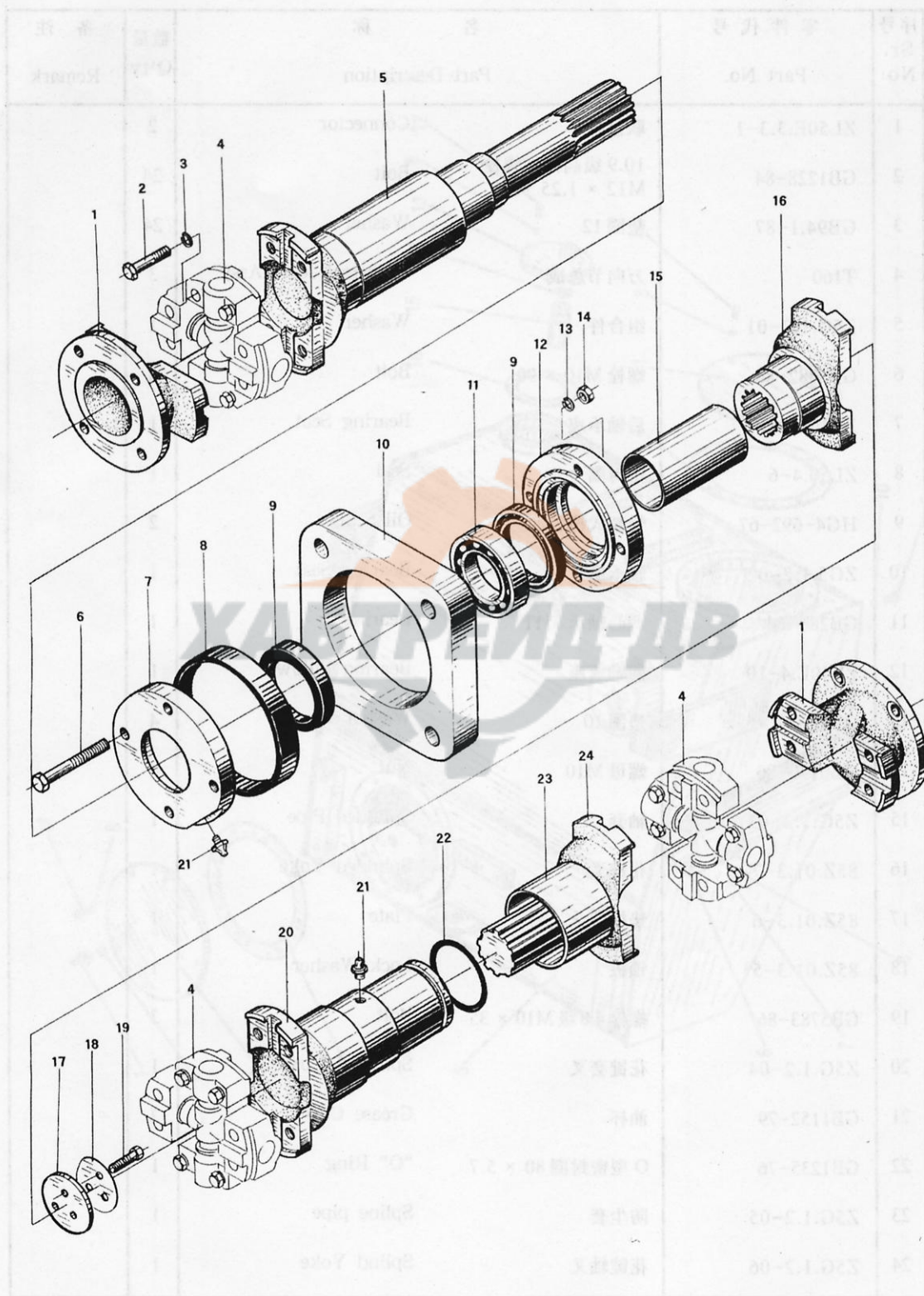



## 5.前传动轴 Front Drive Shaft

序号 Sr. No.	零件代号 Part No.	名称 Part Description	数量 Q'ty	备注 Remark
1	ZL50E.3.3-1	联接盘 Connector	2	
2	GB1228-84	10.9级高强度螺栓 M12 × 1.25 × 55 Bolt	24	
3	GB94.1-87	垫圈 12 Washer	24	
4	T160	万向节总成 Universal Joint Assy	3	
5	Z5G.1.2-01	组合件 Washer	1	
6	GB5782-86	螺栓 M10 × 90 Bolt	4	
7	ZL40E.4-8	后轴承座 Bearing Seat	1	
8	ZL50.4-6	密封圈 Seal	1	
9	HG4-692-67	骨架式橡胶油封 Oil Seal	2	
10	ZG5.1.2-02	轴承座 Bearing Seat	1	
11	GB286-64	调心轴承 3511 Bearing	1	
12	ZL40E.4-10	前轴承座 Bearing Pillow	1	
13	GB93-87	垫圈 10 Washer	4	
14	GB6170-86	螺母 M10 Nut	4	
15	Z5G.1.2-03	轴套 Splined Pipe	1	
16	85Z.01.3-7	花键叉 Splined Yoke	1	
17	85Z.01.3-6	垫板 Plate	1	
18	85Z.01.3-5	锁板 Lock Washer	1	
19	GB5783-86	螺栓 4.8级 M10 × 35 Bolt	3	
20	Z5G.1.2-04	花键套叉 Splined Yoke	1	
21	GB1152-79	油杯 Grease Cup	2	
22	GB1235-76	O型密封圈 80 × 5.7 "O" Ring	1	
23	Z5G.1.2-05	防尘套 Spline pipe	1	
24	Z5G.1.2-06	花键轴叉 Splind Yoke	1	

## 6. 后传动轴总成 Rear Drive Shaft Assy

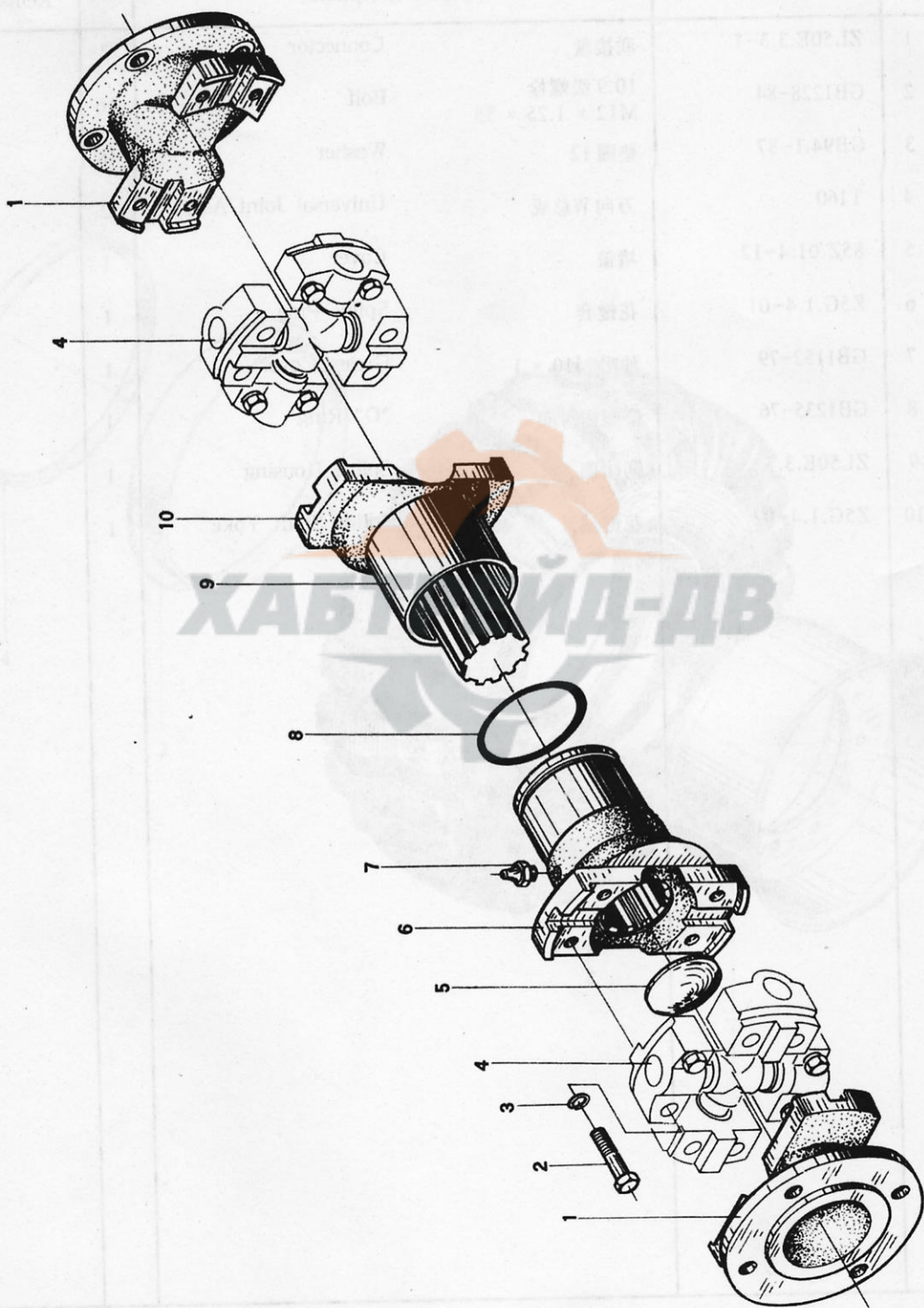



## 6.后传动轴总成 Rear Drive Shaft Assy

序号 Sr. No.	零件代号 Part No.	名 称 Part Description	数量 Q'ty	备 注 Remark
1	ZL50E.3.3-1	联接盘 Connector	2	
2	GB1228-84	10.9级螺栓 Bolt M12 × 1.25 × 55	16	
3	GB94.1-87	垫圈 12 Washer	16	
4	T160	万向节总成 Universal Joint Assy	2	
5	85Z.01.4-12	堵盖 Cover	1	
6	Z5G.1.4-01	花键套 Spline Pipe	1	
7	GB1152-79	油咀 M10 × 1 Grease Cover	1	
8	GB1235-76	O型密封圈 "O" Ring	1	
9	ZL50E.3.3-3	防尘圈 Spline Housing	1	
10	Z5G.1.4-02	花键轴叉 Spline Shaft Yoke	1	

# 7. 轮辋总成 Rim Assy





## 7. 轮辋总成 Rim Assy

序号 Sr. No.	零件代号 Part No.	名 称 Part Description	数量 Q'ty	备 注 Remark
1	ZL50E.5.1.1	轮辋体 Rim Body	1	
2	23.5-25	轮胎 Tire	1	
3	ZL50E.5.1-2	外轮缘 Rim Flange	1	
4	ZL50E.5.1-1	锁圈 Lock Ring	1	

# 8.主减速器总成 Main Transmission Parts

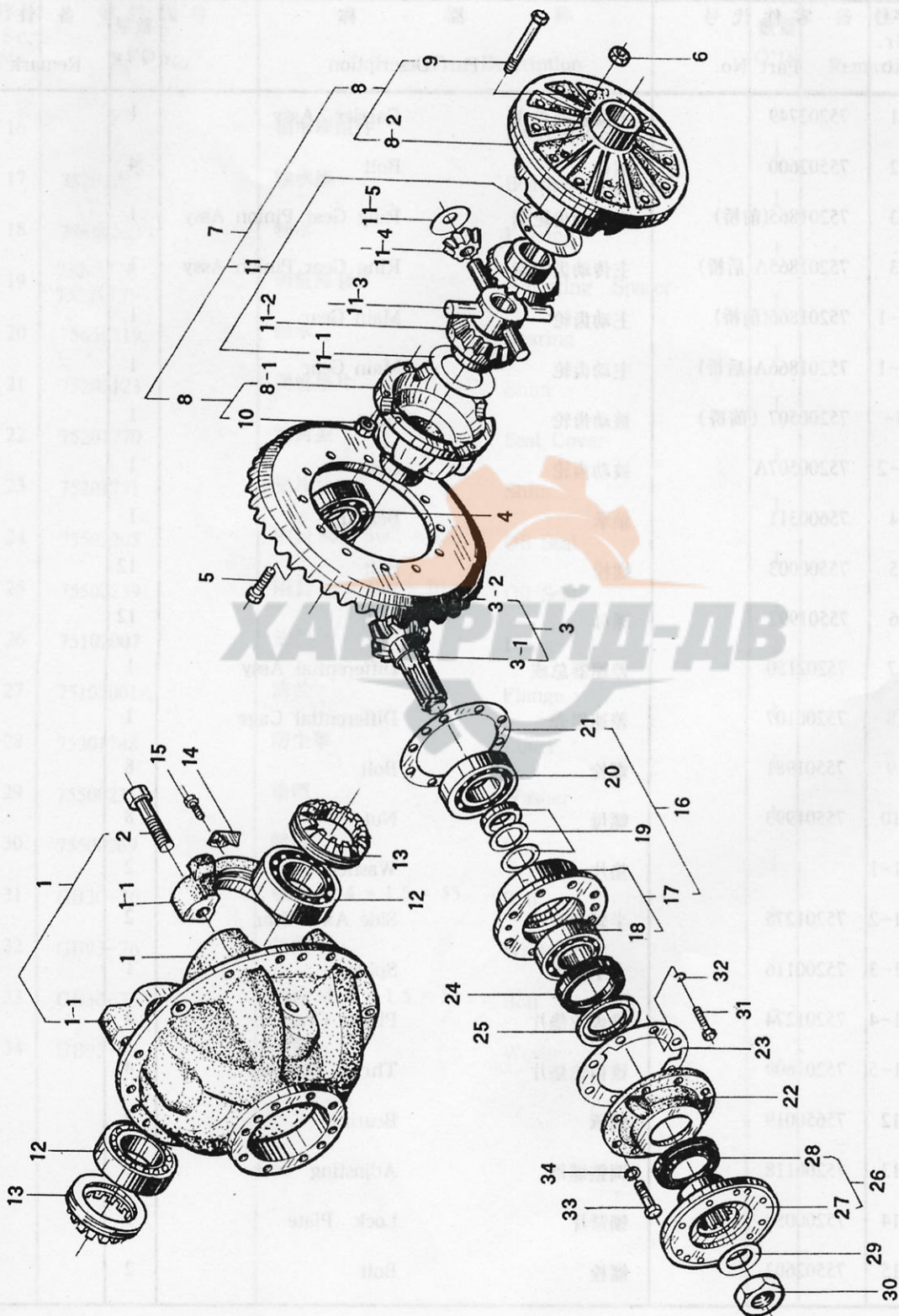



## 8.主减速器总成 Main Transmission Parts

序号 Sr. No.	零件代号 Part No.	名 称 Part Description	数量 Q'ty	备注 Remark
1	75202749	主减器壳总成 Carrier Assy	1	
2	75502600	螺栓 Bolt	4	
3	75201865(前桥)	主传动齿轮副 Ring Gear Pinion Assy	1	
3	75201865A(后桥)	主传动齿轮副 Ring Gear Pinion Assy	1	
3-1	75201866(前桥)	主动齿轮 Main Gear	1	
3-1	75201866A(后桥)	主动齿轮 Main Gear	1	
3-	75200507 (前桥)	被动齿轮 Gear	1	
3-2	75200507A	被动齿轮 Gear	1	
4	75600311	轴承 Bearing	1	
5	75500003	螺栓 Bolt	12	
6	75501992	螺母 Nut	12	
7	75202150	差速器总成 Differential Assy	1	
8	75200107	差速器壳 Differential Cage	1	
9	75501981	螺栓 Bolt	8	
10	75501993	螺母 Nut	8	
11-1		垫片 Washer	2	
11-2	75201275	半轴齿轮 Side Axle Gear	2	
11-3	75200116	十字轴 Spider	1	
11-4	75201274	锥齿轮垫片 Pinion Gear	4	
11-5	75201609	锥齿轮垫片 Thrust Washer	4	
12	75650019	轴承 Bearing	2	
13	75200118	调整螺母 Adjusting Nut	2	
14	75200053	锁紧片 Lock Plate	2	
15	75502602	螺栓 Bolt	2	

## 8.主减速器总成 Main Transmission Parts

序号 Sr. No.	零件代号 Part No.	名 称 Part Description	数量 Q'ty	备注 Remark
16		轴承座组件 Bearing Cage	1	
17	75201767	轴承座 Bearing Cage	1	
18	75650313	轴承 Bearing	1	
19	75201730 75201731	调整隔套 Adjusting Spacer	1	
20	75650319	轴承 Bearing	1	
21	75203123	调整垫片 Shim	1	
22	75201770	油封盖 Seal Cover	1	
23	75201771	垫片 Shim	1	
24	75502205	油封 80 × 100 × 12 Oil Seal	1	
25	75502239	隔套 80 × 100 × 10 Oil Seal	1	
26	75102007	法兰 Flange	1	
27	75102001A	法兰 Flange	1	
28	75201748	防尘罩 Cover	1	
29	75500231	垫圈 Washer	1	
30	75500269	螺母 Nut	1	
31	GB30-76	螺栓 M14 × 1.5 × 55 Bolt	1	
32	GB93-76	垫圈 14 Washer	1	
33	GB30-76	螺栓 M12 × 1.5 × 55 Bolt	7	
34	GB93-76	垫圈 Washer	7	



## 9. 轮边减速总成 Planetary Reductor

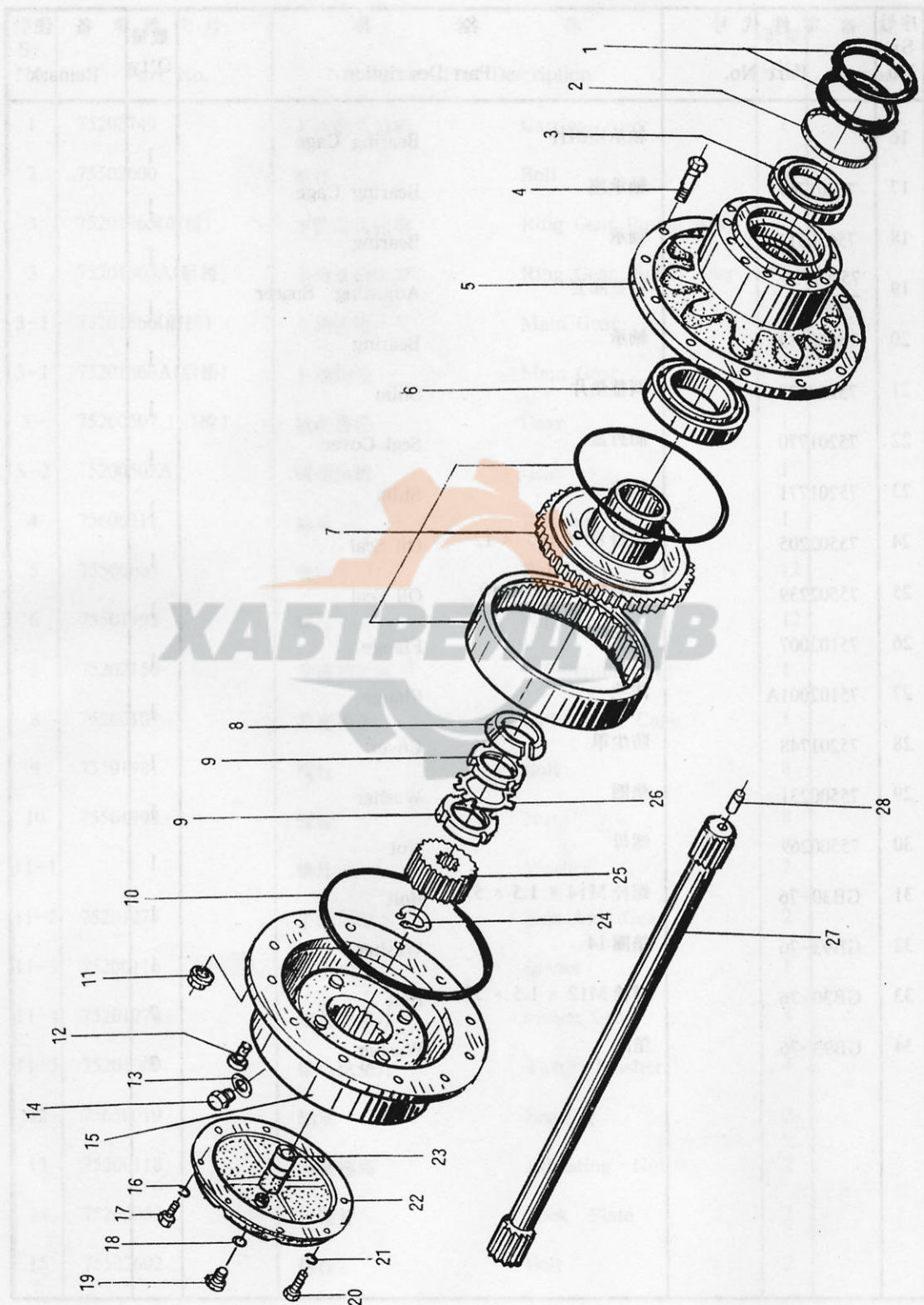

## 9. 轮边减速总成 Planetary Reductor

序号 Sr. No.	零件代号 Part No.	名称 Part Description	数量 Q'ty	备注 Remark
1	HG4-692-67	油封 PD150 × 180 × 16 Oil Seal	2	
2	77000493	隔环 Spacer	1	
3	GB297-84	轴承 2007122 Bearing	1	
4	ZL40.2-9	轮轴螺栓 wheel Pin Assy	20	
5	79002002B	轮毂 Wheel Hub	1	
6	GB297-84	轴承 2007126 Bearing	1	
7	77500938	内齿圈总成 Internal Gear Assy	1	
8	76101041	锥套 Taper	1	
9	75501648	圆螺母 Lock Nut	2	
10	75501957	密封圈 F 337 × 343 Oil Seal Ring	1	
11	ZL40.2-10	轮轴螺母 Wheel Nut	20	
12	GB982-76	螺栓 M10 × 1.5 × 30 Bolt	3	
13	GB982-77	组合垫圈 12 Washer	1	
14	75500195	螺塞 Plug	1	
15	77001142	行星轮架 Planetary Pinion Carrier	1	
6	GB93-87	垫圈 10 Washer	1	
17	GB30-76	螺栓 M10 × 1.25 × 23 Bolt	1	
18	JB982-77	组合垫圈 Washer	1	
19	75500842	螺塞 Plug	1	
20	GB30-76	螺栓 M12 × 1.25 × 23 Bolt	7	
21	GB93-87	垫圈 12 Washer	7	
22	79001544	端盖 Cover	1	
23	73520042	轴衬 Bushing	1	
24	GB894-76	挡圈轮 50 Snap Ring	1	
25	79001524	太阳轮 Sun Gear	1	
26	GB858-76	止退垫 85 Washer	1	
27	79000131B	半轴 Axle Shalf	1	
28	77000044	调整销 Adjusting Pin	1	



# 10. 变速箱系统 Transmission System

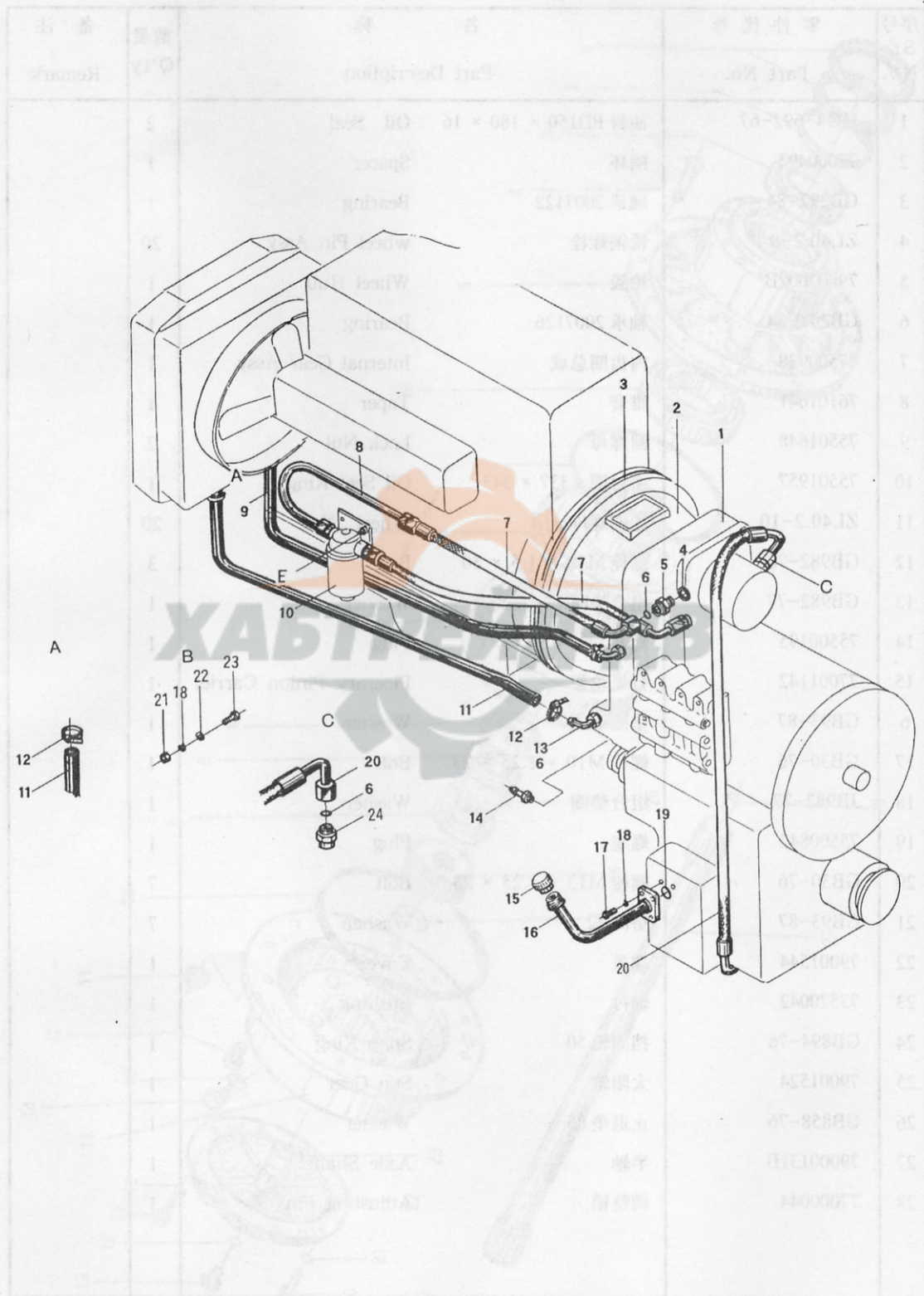

## 10. 变速箱系统 Transmission System

序号 Sr. No.	零件代号 Part No.	名 称 Part Description	数量 Q'ty	备 注 Remark
1	Z5G.1.3.5	变速箱 Transmission	1	
2	ZL50.3.4	变矩器 Converter	1	
3	ZL40.3-3	垫 Pad	1	
4	JB982-77	组合垫 33 Washer	2	
5	Z5G.1.3-3	接头 Joint	4	
6	GB3452.1-82	O 型圈 22.4 × 3.55 "O" Ring	10	
7	Z5G.1.3.2	胶管 22 II -900 Pipe	2	
8	Z5G.1.3.1	弯管 Pipe	1	
9	Z5G.1.3-4	胶管 Rubber Hose	1	
10	ZL40.3.2A	滤清器 Filter	1	
11	Z5G.1.3-2	胶管 Rubber Hose	1	
12	JB3616.1-84	双钢丝箍 34-38 Clamp	4	
13	ZL40.3.1.2	接头 Joint	2	
14	ZL50E.2.1	胶管接头 Joint	1	
15	Z4G.1.2.4.2	加油管 Pipe	1	
16	Z4G.1.2.4.1	加油管 Pipe	1	
17	GB5783-86	螺栓 M10 × 30 Bolt	4	
18	GB93-87	垫圈 10 Washer	6	
19	GB3452.1-82	O 型圈 35.3 × 3.55 "O" Ring	1	
20	Z5G.1.3.4	胶管 25 II Rubber Hose	1	
21	GB6170-86	螺母 M10 Nut	2	
22	GB97.1-85	垫圈 10 Washer	2	
23	GB5780-86	螺栓 M10 × 35 Bolt	2	
24	Z5G.1.3.5	接头 Joint	2	



# 11. 液力变矩器 Torque Converter

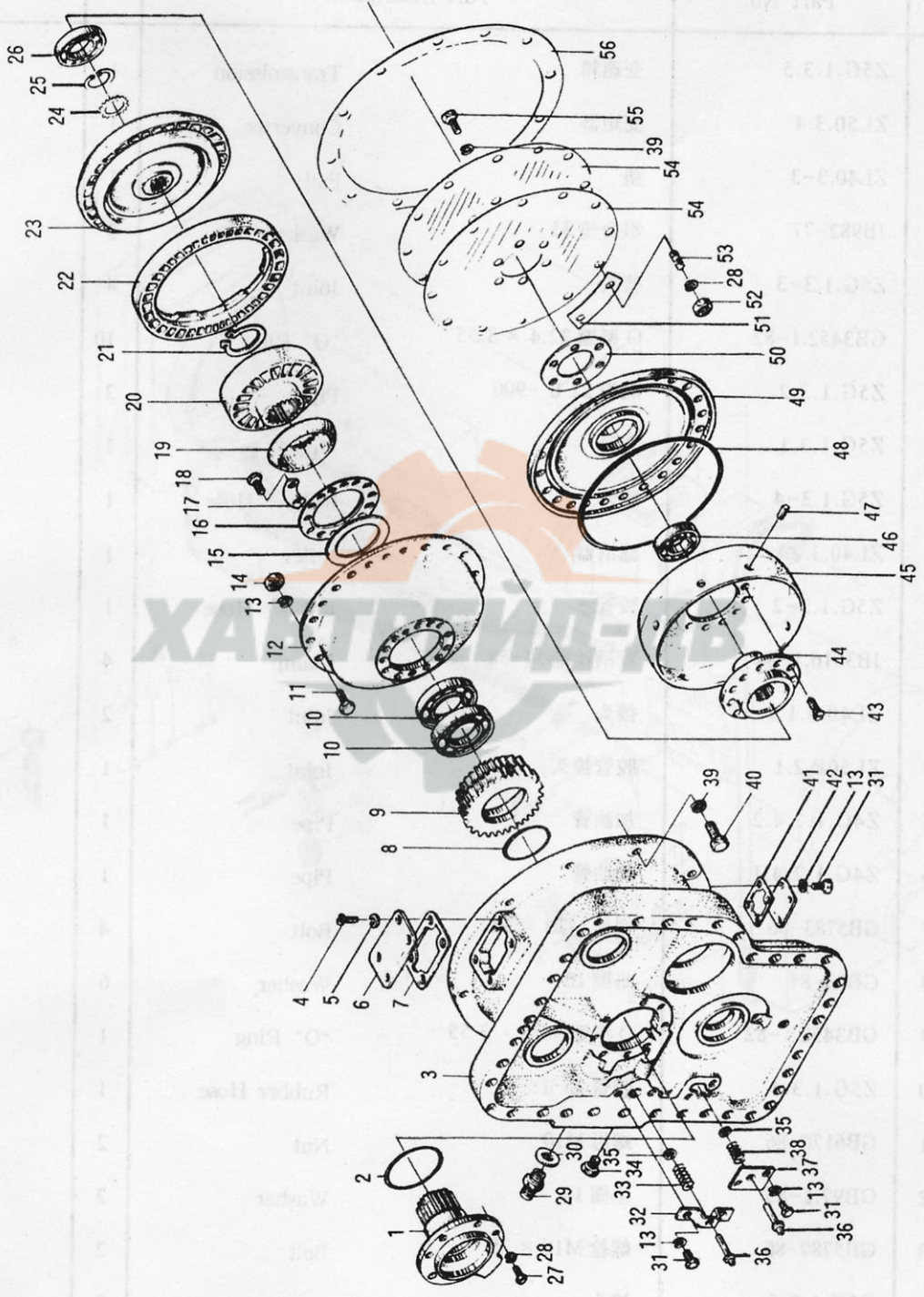

## 11.液力变矩器 Torque Converter

序号 Sr. No.	零件代号 Part No.	名 称 Part Description	数量 Q'ty	备 注 Remark
1	402222	导轮座 Stator Guide Sleeve	1	
2	GB3452.1-82	O型密封 F128 × 3.55 "O" Ring	1	
3	402216	壳体 Converter Housing	1	
4	GB67-85	半圆头螺栓钉 M6 × 16 Serew	4	
5	GB93-87	弹簧垫圈 6 Lock Washer	4	
6	402214	垫板 Plate	1	
7	402215	纸垫 Paper Pad	1	
8	402221	密封环 Seal Ring	1	
9	402220	齿轮 Gear	1	
10	GB276-89	轴承 117(130 × 85 × 22) Bearing	2	
11	GB5782-86	螺栓 M8 × 35 Bolt	24	
12	402227	泵轮 Imperller	1	
13	GB93-87	弹簧垫圈 8 Lock Washer	36	
14	GB6170-86	螺母 M8 Nut	24	
15	402224	调整垫片 Adjustable Washer	1组	
16	402226	压板 Gland	1	
17	402218	防松垫片 Lock Washer	6	
18	GB5783-86	螺栓 M8 × 30 Bolt	14	
19	402225	导油环 Leading Oil Ring	1	
20	402217	导轮 Stator	1	
21	GB894.1-86	挡圈 80 Snap Ring	1	
22	402209	一级涡轮 I Turbine	1	
23	402212-213	二级涡轮 II Turbine	1	
24	402238	花建垫片 Washer	1组	
25	GB893.1-86	挡圈 50 Snap Ring	1	
26	GB276-89	轴承 113(100 × 65 × 18) Bearing	1	
27	GB5783-86	螺栓 M10 × 28 Bolt	8	
28	GB93-87	弹簧垫圈 10 Lock Washer	20	
29	402111	管接头 Joint	2	
30	402106	垫圈 Washer	2	
31	GB5783-86	螺栓 M8 × 16 Bolt	8	



## 11.液变矩器 Torque Converter

序号 Sr. No.	零件代号 Part No.	名称 Part Description	数量 Q'ty	备注 Remark
32	402228	阀盖 Valve Cover	1	
33	402229	弹簧 Spring	1	
34	402223	螺塞 Plug	1	
35	402232	垫片 Washer	2	
36	402233	阀杆 Valve Stem	2	
37	402230	垫板 Plate	1	
38	402231	弹簧 Spring	1	
39	GB93-87	弹簧垫圈 12 Lock Wsher	36	
40	GB5782-86	螺栓 M12 × 45 Bolt	12	
41	402235	纸垫 Paper pad	1	
42	402234	垫板 Plate	1	
43	GB869-86	沉头螺钉 8 × 16 Screw	12	
44	402206	一级涡轮壳 I Turbine Coverter Housing	1	
45	402207	一级涡轮架 I Turbine Guide Sleeve	1	
46	GB276-89	轴承 210 (90 × 50 × 20) Bearing	1	
47	402208	弹性销 Pin	9	
48	402236	O型密封圈 "O" Ring	1	
49	402203	罩轮 Cover	1	
50	402210	圆垫板 Plate	1	
51	402201	垫片 Washer	6	
52	GB6171-86	螺母 M10 × 1 Nut	12	
53	402237	双头螺栓 Bolt	12	
54	402202	弹性板 S=1.0 Plate	2	
55	GB5782-86	螺栓 M12 × 30 Bolt	6	
56	402211	纸垫 Paper Pad	1组	

## 12. 变速箱(一) Transmission(1)

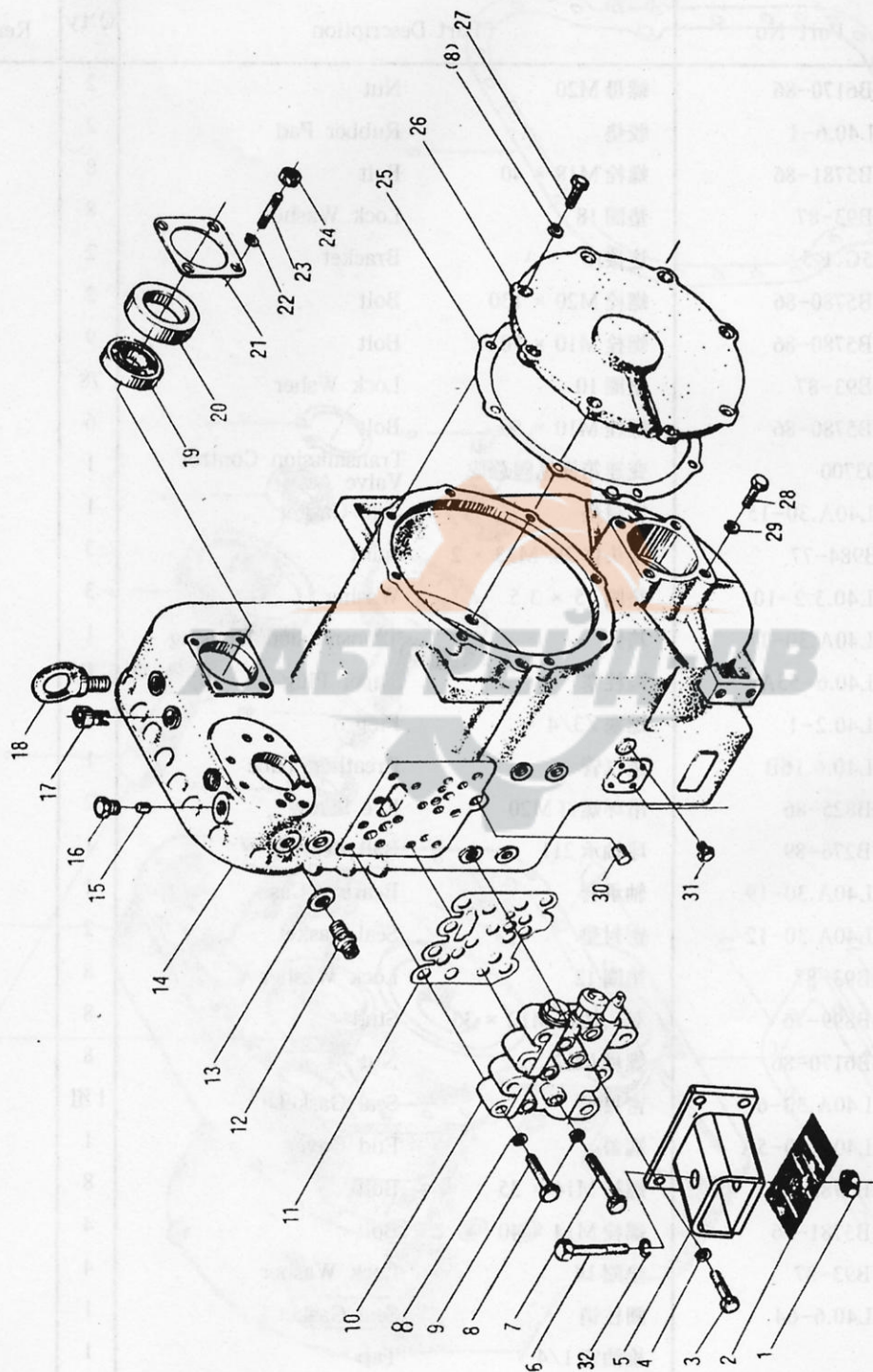



## 12.变速箱 (一) Transmission(1)

序号 Sr. No.	零件代号 Part No.	名 称 Part Description	数量 Q'ty	备 注 Remark	
1	GB6170-86	螺母 M20	Nut	2	
2	ZL40.6-1	胶垫	Rubber Pad	2	
3	GB5781-86	螺栓 M18 × 40	Bolt	8	
4	GB93-87	垫圈 18	Lock Washer	8	
5	Z5G.1.5	连接座	Bracket	2	
6	GB5780-86	螺栓 M20 × 130	Bolt	2	
7	GB5780-86	螺栓 M10 × 70	Bolt	9	
8	GB93-87	垫圈 10	Lock Wsher	78	
9	GB5780-86	螺栓 M10 × 50	Bolt	6	
10	403700	变速箱操纵阀总成	Transmission Control Valve Assy	1	
11	ZL40A.30-15	密封垫	Seal Gasket	1	
12	JB984-77	接头体 28/M33 × 2	Joint	3	
13	ZL40.3.2-10	垫圈 35 × 3.5	Washer	3	
14	ZL40A.30-1	箱体	Transmission Housing	1	
15	ZL40.6-55A	圆柱塞	Taper Plug	1	
16	ZL40.2-1	螺塞 Z3/4 "	Plug	1	
17	ZL40.6.16B	透气管	Breather Tube	1	
18	GB825-86	吊环螺钉 M20	Eye Screw	2	
19	GB276-89	球轴承 211	Ball Bearing	1	
20	ZL40A.30-19	轴承套	Bearing Case	1	
21	ZL40A.30-12	密封垫	Seal Gasket	2	
22	GB93-87	垫圈 12	Lock Washer	8	
23	GB899-76	双头螺栓 M12 × 36	Stud	8	
24	GB6170-86	螺母 M12	Nut	8	
25	ZL40A.30-6	密封垫	Seal Gasket	1组	
26	ZL40A.30-5A	端盖	End Cover	1	
27	GB5783-86	螺栓 M14 × 35	Bolt	8	
28	GB5781-86	螺栓 M14 × 40	Bolt	4	
29	GB93-87	垫圈 14	Lock Washer	4	
30	ZL40.6-64	圆柱销	Seal Gasket	1	
31		检油塞 1/4 "	Tap	1	
32	GB93-87	垫圈 20	Lock Washer	2	

### 13. 变速箱(二) Transmission(2)

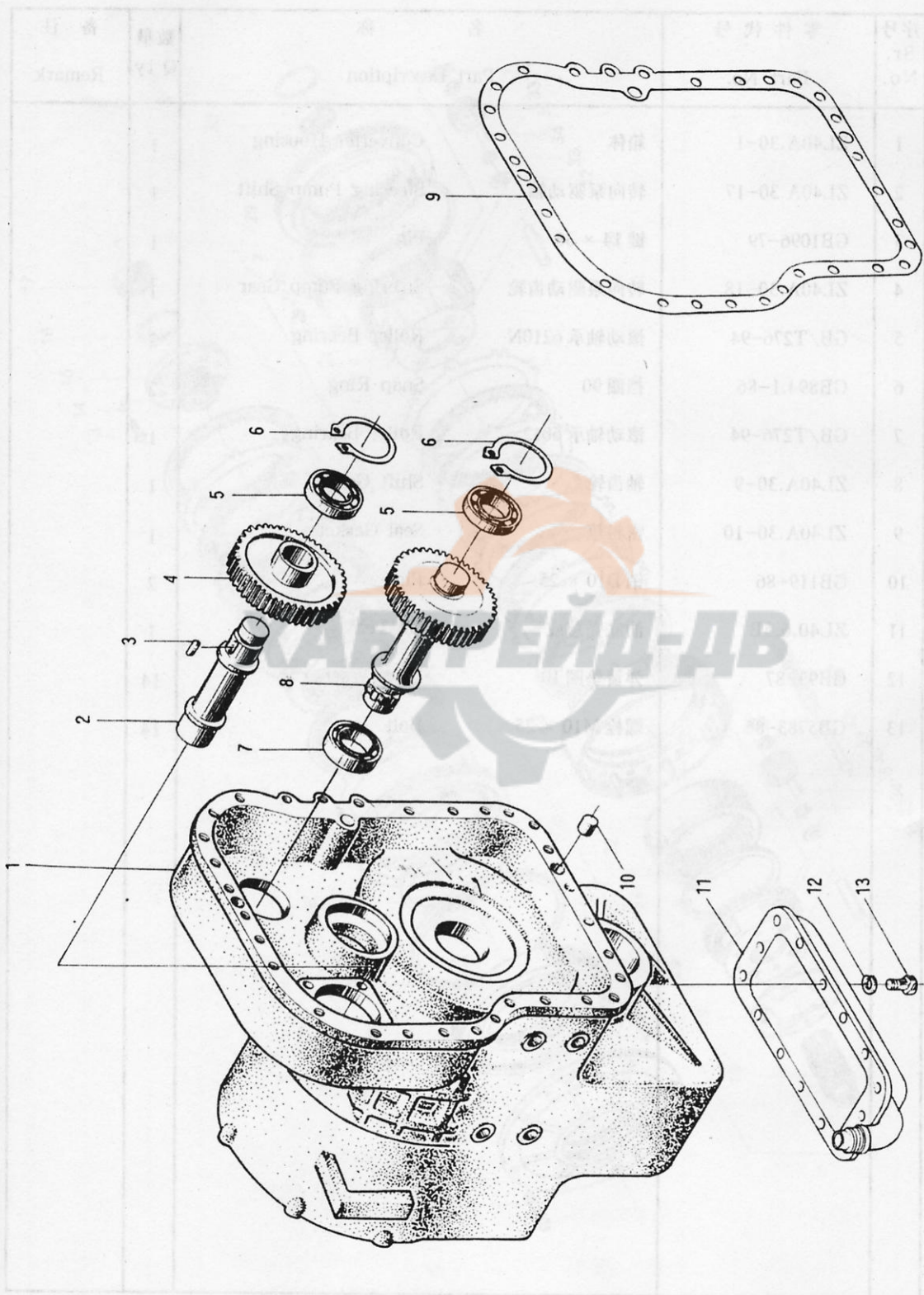



### 13. 变速箱 (二) Transmission(2)

序号 Sr. No.	零件代号 Part No.	名 称 Part Description	数量 Q'ty	备 注 Remark
1	ZL40A.30-1	箱体 Converter Housing	1	
2	ZL40A.30-17	转向泵驱动轴 Steering Pump Shift	1	
3	GB1096-79	键 14 × 36 Pin	1	
4	ZL40A.30-18	转向泵驱动齿轮 Steering Pump Gear	1	
5	GB/T276-94	滚动轴承 6210N Roller Bearing	2	
6	GB894.1-86	挡圈 90 Snap Ring	2	
7	GB/T276-94	滚动轴承 6012 Roller Bearing	1	
8	ZL40A.30-9	轴齿轮 Shift Gear	1	
9	ZL40A.30-10	密封垫 Seal Gasket	1	
10	GB119-86	销 D10 × 25 Pin	2	
11	ZL40.6.5B	油底壳总成 Oil Pan	1	
12	GB93-87	弹簧垫圈 10 Lock Washer	14	
13	GB5783-86	螺栓 M10 × 25 Bolt	14	

# 14. 变速箱(三) Transmission(3)





## 14. 变速箱(三) Transmission(3)

序号 Sr. No.	零件代号 Part No.	名 称 Part Description	数量 Q'ty	备 注 Remark
1	GB5783-86	螺栓 M12 × 40 Bolt	8	
2	GB93-87	弹簧垫圈 12 Lock Washer	8	
3	ZL40.6-33A	中盖 Medium Cover	1	
4	ZL40.6.12-1A	一档油缸 1st Forward Cylinder	1	
5	ZL40.6-63	固定板 Anchor Plate	1	
6	GB1235-76	O 型圈 20 × 2.4 "O" Ring	1	
7	ZL40.6.13-1A	外密封环 Outer Seal Ring	2	
8	ZL40.6.8-3A	内密封环 Inner Seal Ring	1	
9	ZL40.6.13-3A	一档活塞 1st Forward Piston	1	
10	ZL40.30.5-31	一档内齿轮总成 Inner Gear Ring Assy	1	
11	ZL40.6.14	倒档一档主动片 Reverse-1st Driving Plate	8	
12	ZL40.6-48	倒档一档从动片 Reverse-1st Friction Plate	8	
13	GB5783-86	螺栓 M10 × 30 Bolt	4	
14	GB93-87	弹簧垫圈 10 Lock Washer	4	
15	ZL40A.30.5-17	直接档连接盘 Direct Forward Connecting Flange	1	
16	GB894.1-86	档圈 90 Snap Ring	2	
17	GB277-89	球轴承 50210 (50 × 90 × 20) Ball Bearing	1	
18	ZL40A.30.5-18	太阳轮 Sun Gear	1	
19	ZL40.6-44	止动盘 Lock Plate	1	
20	ZL40.6-45	一档行星架 1st Forward Planetary Carrier	1	
21	ZL40.6-47	挡圈 Snap Ring	1	
22	ZL40A.30.5-23	倒档内齿圈 Reverse Inner Gear Ring	1	
23	ZL40.6.4	摩擦片隔离架总成 Clutch Anchor Assy	1	
24	ZL40A.30.5-32	倒档行星架 Reverse Planetary Carrier	1	

14. 变速箱(三) Transmission(3)

序号 Sr. No.	零件代号 Part No.	名 称 Part Description	数量 Q'ty	备注 Remark
25	ZL40.6-51	止动垫圈 Lock Washer	4	
26	GB93-87	弹簧垫圈 8 Lock Washer	4	
27	GB5783-86	螺栓 M8 × 14 Bolt	4	
28	ZL40.6.15-3A	内密封环 Inner Seal Ring	1	
29	ZL40.6.15-1A	倒档活塞体 Reverse Piston	1	
30	GB276-89	球轴承 110 (50 × 80 × 16) Ball Bearing	1	
31	ZL40.6-16	一档行星轴 1st Forward Planetary Shaft	4	
32	ZL40.6-50	垫片 Washer	16	
33	ZL40.6-10	隔离套 Spacer	16	
34	GB309-84	滚针 F 4 × 35 Needle Roller	176	
35	ZL40A.30.5-13	行星轮 Planetary Gear	8	
36	ZL40.6-52	弹簧销轴 Guide Pin	15	
37	ZL40.6-53A	弹簧 Spring	15	
38	ZL40.6-15	倒档行星轴 Reverse Planet Splindle	4	



# 15. 变速箱(四) Transmission(4)

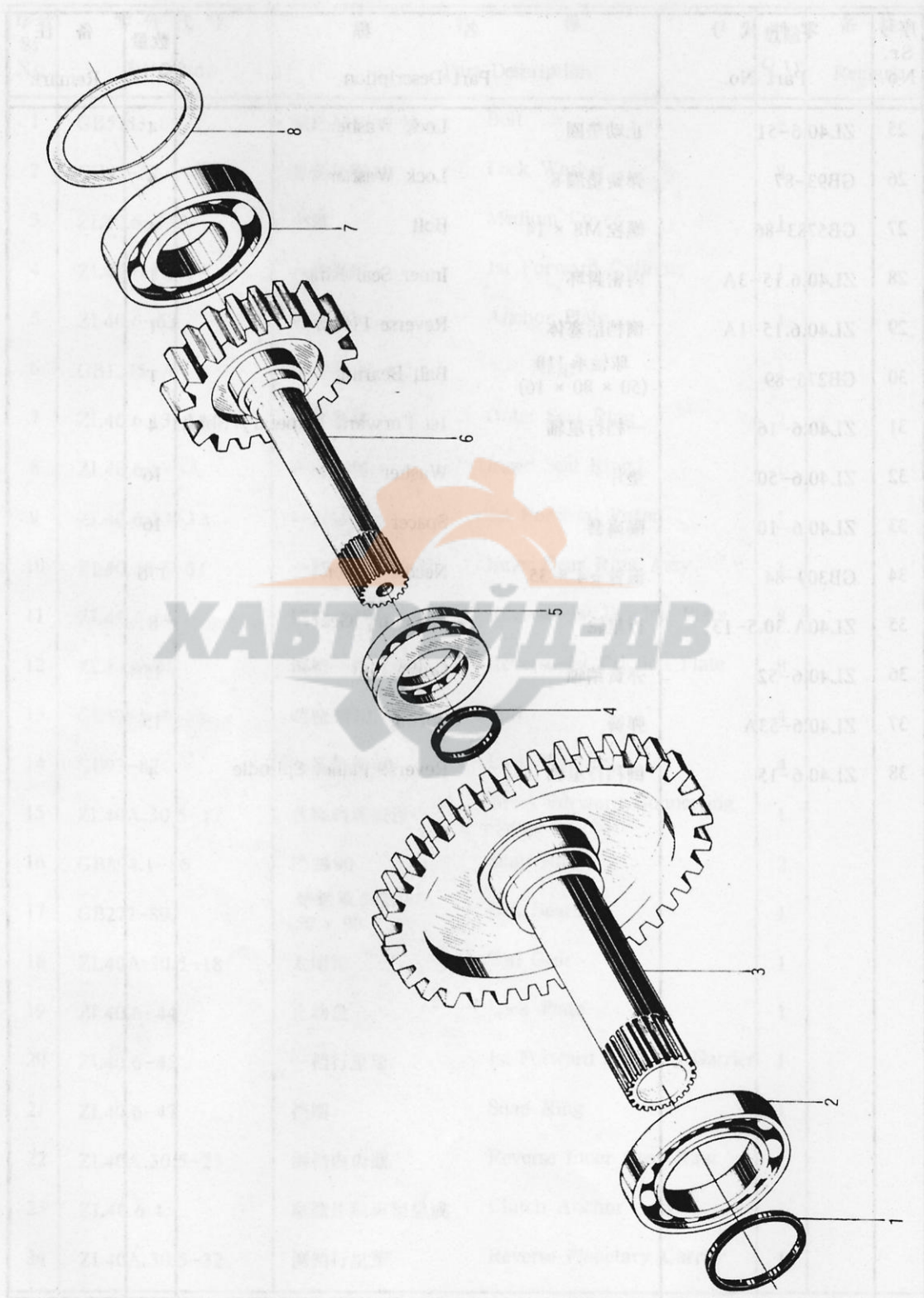

15.变速箱(四) Transmission(4)

序号 Sr. No.	零件代号 Part No.	名称 Part Description	数量 Q'ty	备注 Remark
1	ZL40A.30.1-8	旋转油封 Seal Ring	1	
2	GB276-89	球轴承 116(80 × 125 × 22) Ball Bearing	1	
3	ZL40A.30.6-2	输入二级齿轮 Secondary Stage Input Gear	1	
4	ZL40A.30.1-9	旋转油封 Seal Ring	1	
5	GB301-84	推力球轴承 8111 Thrust Ball Bearing	1	
6	ZL40A.30.6-1	输入一级齿轮 Primary Stage Input Gear	1	
7	GB276-89	球轴承 311(55 × 120 × 29) Ball Bearing	1	
8	ZL40A.30.6-3	调整垫片 Adjusting Washer	1组	



# 16. 变速箱(五) Transmission(5)

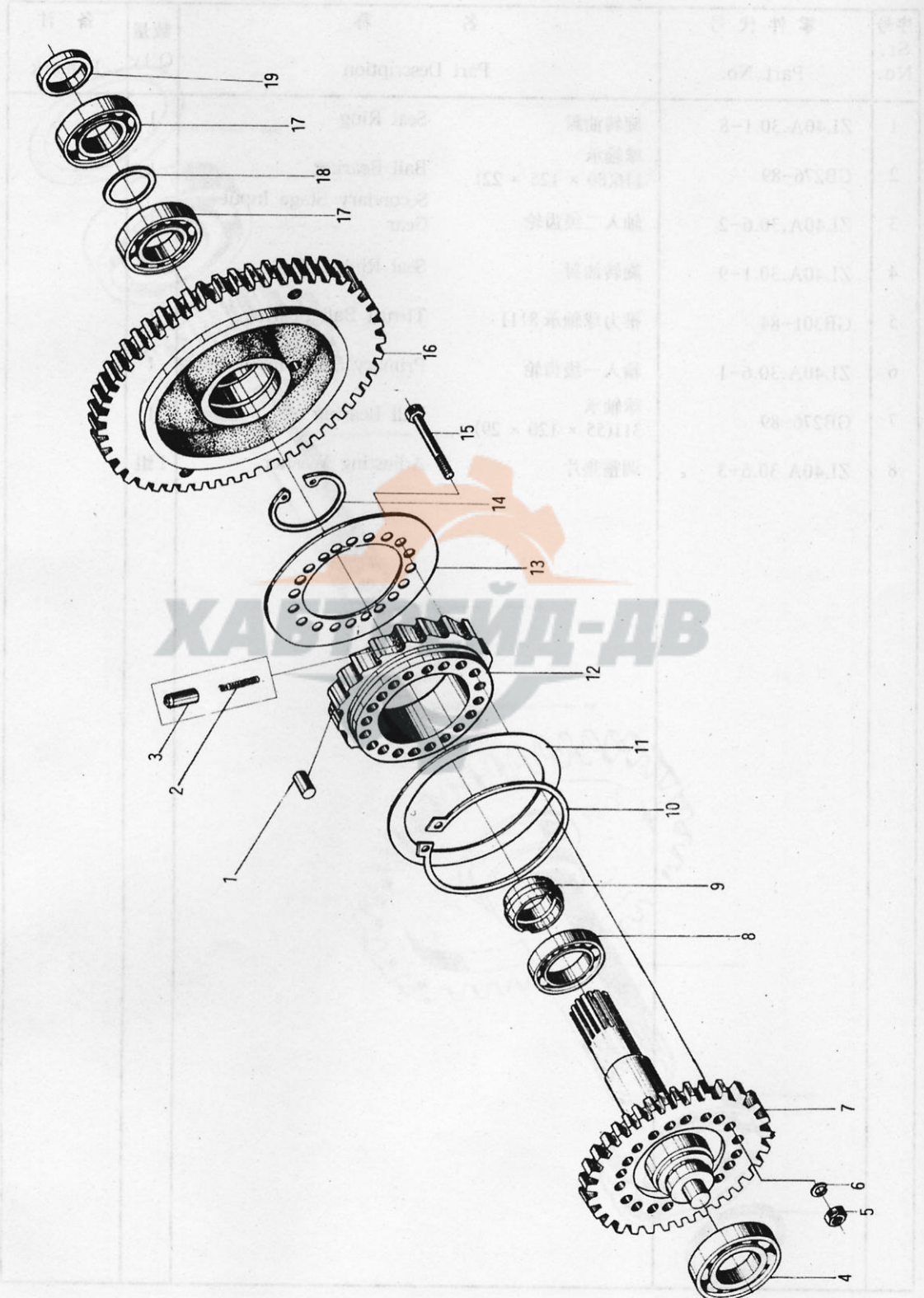

16. 变速箱(五) Transmission(5)

序号 Sr. No.	零件代号 Part No.	名 称 Part Description	数量 Q'ty	备 注 Remark
1	ZL40A.30.5-38A	滚柱 $F 15 \times 32$ Cylinder Roller	20	
2	ZL40A.30.5-39A	弹簧                      Spring	40	
3	ZL40A.30.5-37A	顶销                      Pin	40	
4	GB276-89	球轴承 211(55 × 100 × 21)      Ball Bearing	1	
5	GB6171-86	螺母 M10 × 1              Nut	20	
6	GB93-87	弹簧垫圈 10              Lock Washer	20	
7	ZL40A.30.5-1	中间输出轴              Medium Input Shaft	1	
8	GB276-85	球轴承 110(50 × 80 × 16)      Ball Bearing	2	
9	ZL40.6-10	隔离套                      Space Bushing	1	
10	GB894.1-86	挡圈 170                  Snap Ring	1	
11	ZL40A.30.5-34A	左端盖                      Left End Cover	1	
12	ZL40A.30.5-40A	内环凸轮                  Inner Ring Cam	1	
13	ZL40A.30.5-36A	右端盖                      Right End Cover	1	
14	GB893.1-86	挡圈 80                      Snap Ring	1	
15	ZL40A.30.5-41A	螺栓                          Bolt	20	
16	ZL40A.30.5-35A	外环齿轮                  Output Ring Gear	1	
17	GB276-89	球轴承 50210(50 × 90 × 20)      Ball Bearing	2	
18	ZL40.6-12	间隔环                      Bearing Cage	1	
19	ZL40.6-13	间隔套                      Space Bushing	1	



# 17. 变速箱(六) Transmission(6)

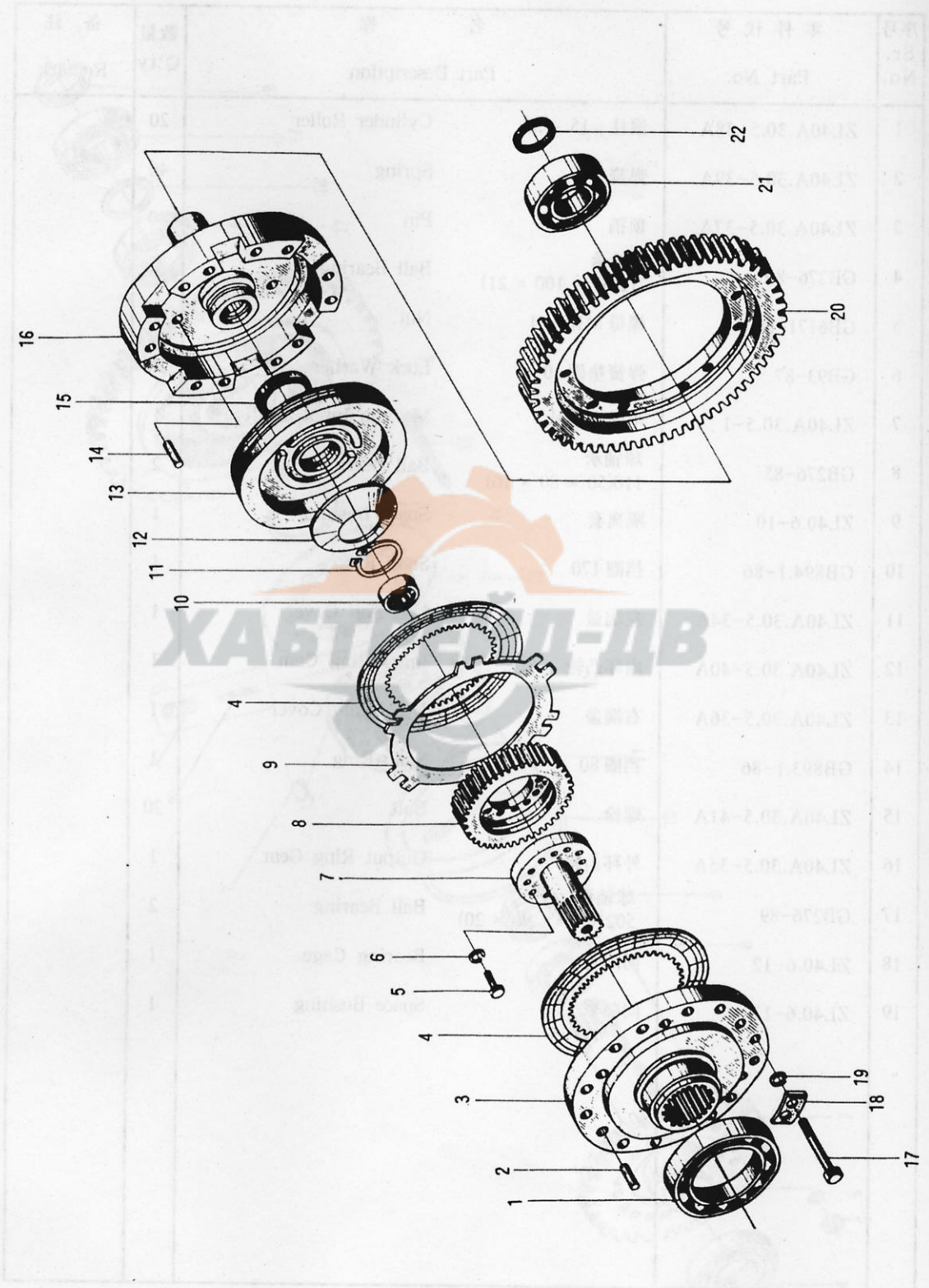

17.变速箱(六) Transmission(6)

序号 Sr. No.	零件代号 Part No.	名称 Part Description	数量 Q'ty	备注 Remark
1	GB276-89	球轴承 122(110 × 170 × 28)	1	
2	ZL40.6.10-2	圆柱销	6	
3	ZL40A.30.1-1	直接档受压盘	1	
4	ZL40A.30.1.1A	二档主动片	2	
5	GB5783-86	螺栓 M8 × 20	12	
6	GB93-87	弹簧垫圈 8	12	
7	ZL40A.30.1-2A	直接档轴	1	
8	ZL40A.30.1-3A	二档齿圈	1	
9	ZL40A.30.1-10	二档从动片	1	
10	GB276-89	球轴承 204(20 × 47 × 14)	1	
11	GB894.1-87	档圈 65	1	
12	ZL40.6-39	蝶形弹簧	1	
13	ZL40A.30.1-5	直接档活塞	1	
14	GB119-86	销 D10 × 30	3	
15	ZL40A.30.1-8	旋转油封	1	
16	ZL40A.30.1-7	直接档油缸	1	
17	GB5785-86	螺栓 M12 × 1.25 × 100	12	
18	ZL40.6-88	止动垫片	6	
19	GB93-87	弹簧垫圈 12	12	
20	ZL40A.30.1-6	中间输出齿轮	1	
21	GB276-89	球轴承 312(60 × 130 × 31)	1	
22	ZL40A.30.1-9	旋转油封	1	



# 18. 变速箱(七) Transmission(7)

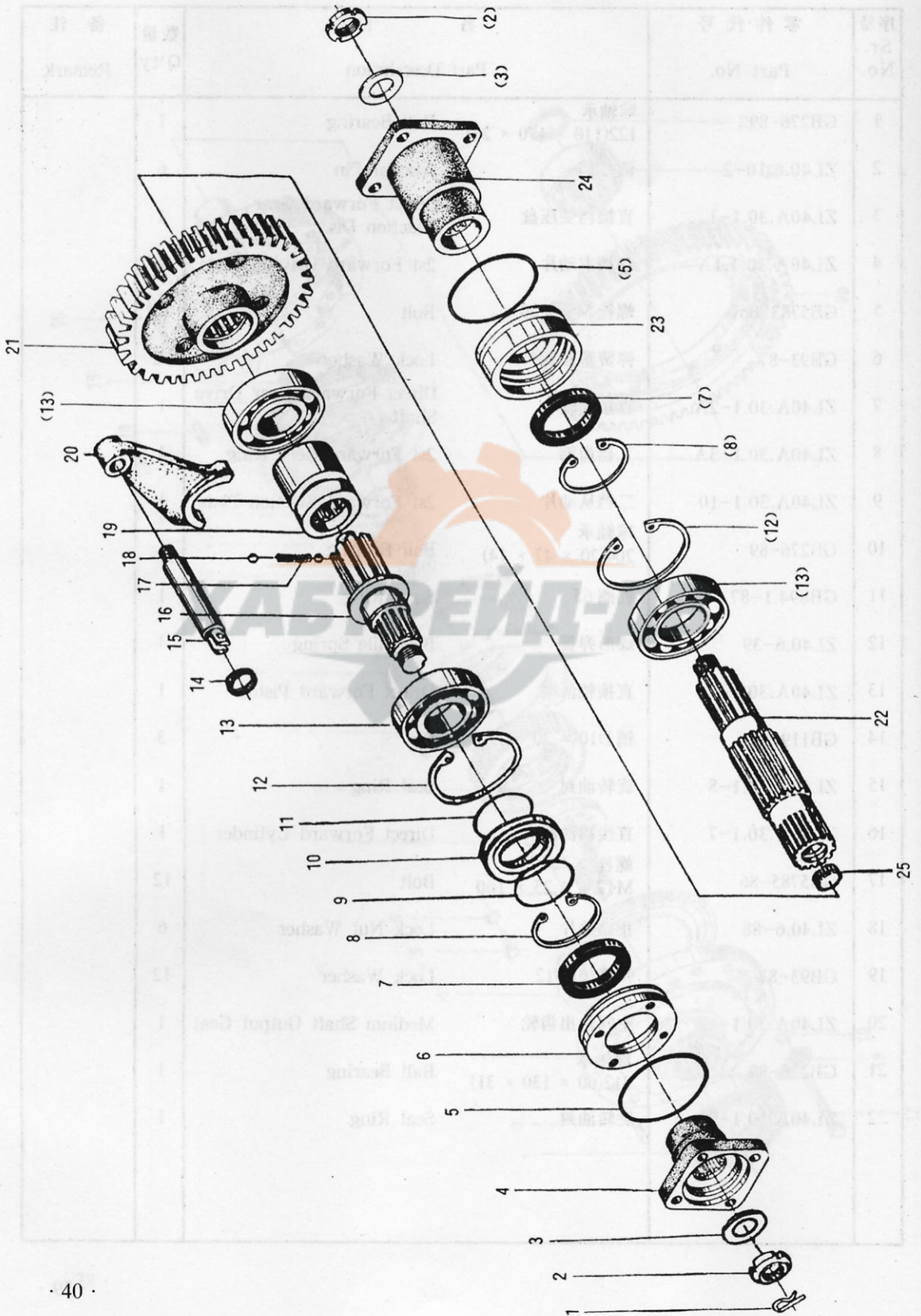

18.变速箱(七) Transmission(7)

序号 Sr. No.	零件代号 Part No.	名 称 Part Description	数量 Q'ty	备 注 Remark
1	GB91-76	销 6 × 60 Pin	2	
2	ZL40A.30.3-1	带槽螺母 Lock Nut	2	
3	ZL40A.30.3-9	垫圈 Washer	2	
4	ZL40A.30.3-2	法兰 Flange	1	
5	GB1235-76	O 型圈 130 × 5.7 "O" Ring	2	
6	ZL40.6-24	油封座 Oil Seal Seat	1	
7	HG4-692-67	油封 SG70 × 95 × 12 Oil Seal	2	
8	GB893.1-86	挡圈 95 Snap Ring	2	
9	GB1235-76	O 型圈 65 × 3.1 "O" Ring	1	
10	ZL40.30.3-4	隔套 Spacer	1	
11	GB1235-76	O 型圈 75 × 3.1 "O" Ring	1	
12	GB893.1-86	挡圈 130 Snap Ring	2	
13	GB276-89	轴承 312 Ball Bearing	3	
14	HG4-692-67	油封 SD25 × 40 × 10 Oil Seal	1	
15	ZL40A.30.3-15	前后桥联接拉杆 Axle Release Lever	1	
16	ZL40.6.6-6	后输出轴 Rear Output Shaft	1	
17	ZL40.6-25	弹簧 Spring	1	
18	GB308-77	钢球 $F_{10}$ Steel Ball	2	
19	ZL40.6.6-5	滑套 Sleeve	1	
20	ZL40.6-20	前后桥联接拨叉 Axle Release Yoke	1	
21	ZL40A.30.3-8	输出轴齿轮 Output Shaft Gear	1	
22	ZL40A.30.3-10	前输出轴 Front Output Shaft	1	
23	ZL40.6-28A	油封盖 Oil Seal Cover	1	
24	ZL40.13.1-3	法兰 Flange	1	
25	ZL40.6.6-1	轴套 Bushing	1	



# 19. 变速箱(八) Transmission(8)

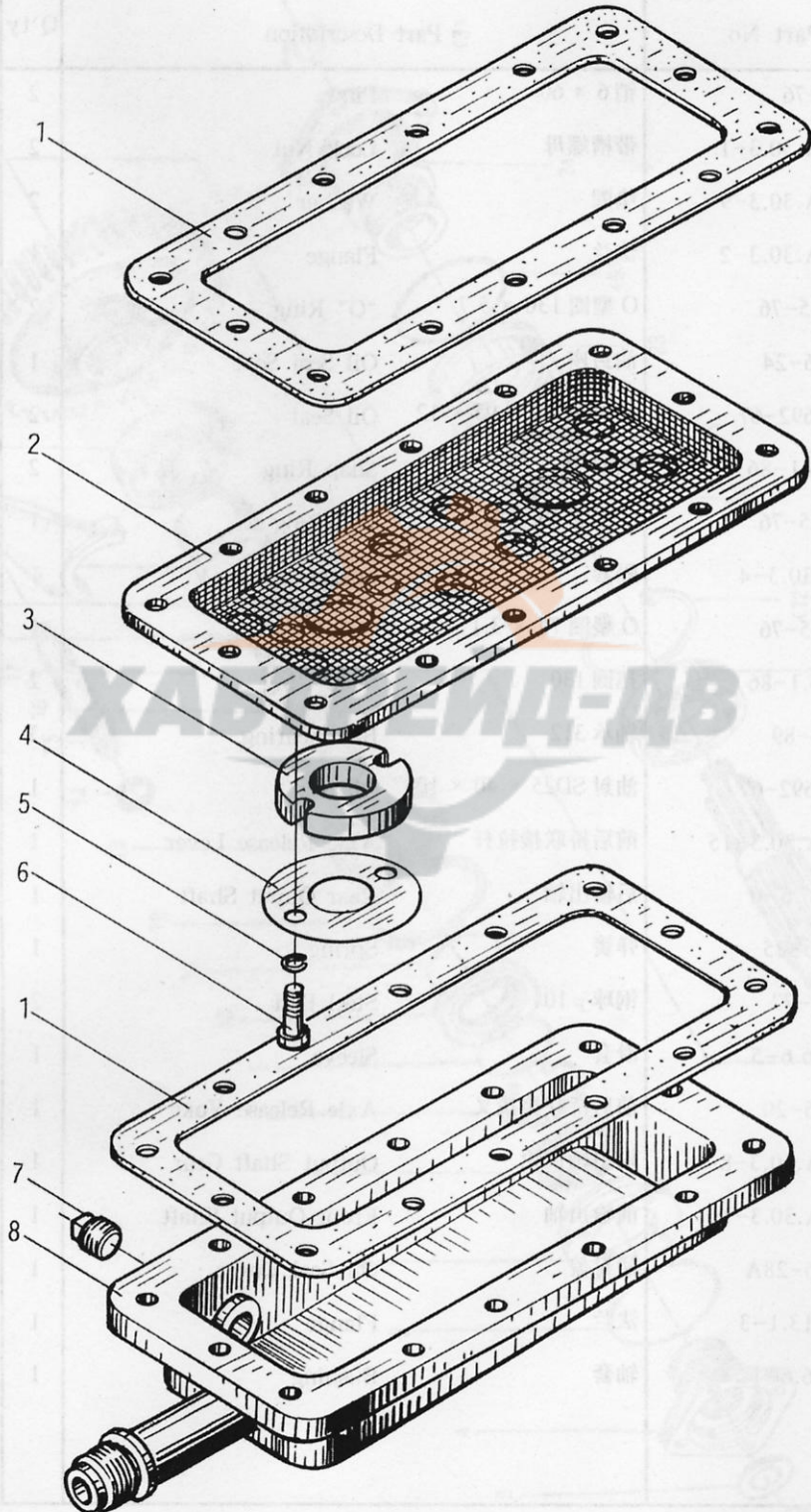

19. 变速箱(八) Transmission(8)

序号 Sr. No.	零件代号 Part No.	名称 Part Description	数量 Q'ty	备注 Remark
1	403406	密封垫 Seal Gasket	2	
2	ZL40A.30.4.2	滤网支架 Bracket	1	
3	ZL40.6.5-3	永久磁铁 F 80 Permanent Magnet	2	
4	ZL40.6.5-1	垫板 Pad	2	
5	GB93-87	垫圈 6 Lock Washer	4	
6	GB5783-86	螺栓 M6 × 25 Bolt	4	
7	402223	螺塞 ZG3/4" Plug	1	
8	ZL40A.30.4.1	油底壳体 Oil Sump	1	



## 20. 滤清器 Oil Filter

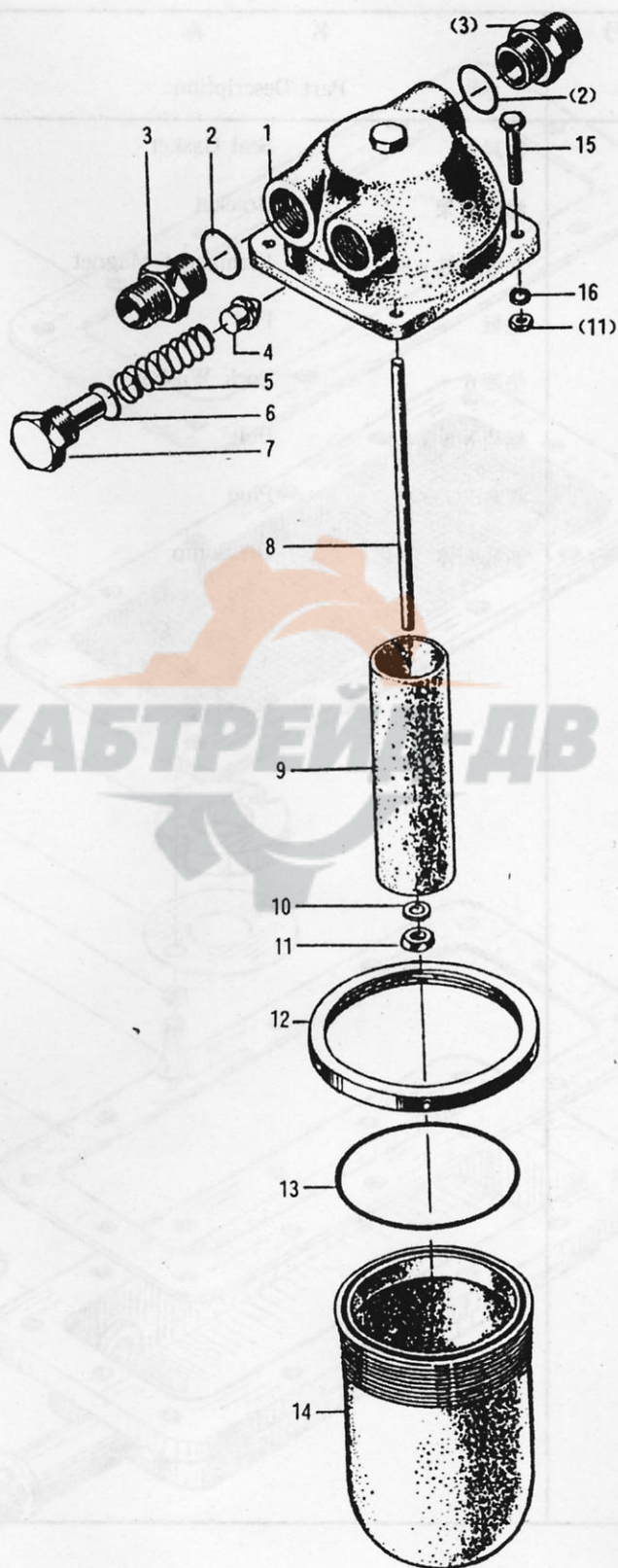

20. 滤清器 Oil Filter

序号 Sr. No.	零件代号 Part No.	名称 Part Description	数量 Q'ty	备注 Remark
1	ZL40.3.2-1A	上盖 Filter Head	1	
2	ZL40.3.2-10	垫圈 Washer	2	
3	JB984-77	接头体 28 Joint	2	
4	ZL40.3.2-6	活塞 Poppet	1	
5	ZL40.3.2-7	弹簧 Spring	1	
6	GB1235-76	O 型圈 30 × 3.1 "O" Ring	1	
7	ZL40.3.2-8	螺塞 Plug	1	
8	ZL40.3.2-3	螺杆 Center Stud	1	
9	ZL40.3.2-2	滤芯 Filter Element	1	
10	ZL40.3.2-5	垫片 Seal	1	
11	GB6170-86	螺母 M8 Nut M8	5	
12	ZL40.3.2-9	固紧螺母 Lock Nut	1	
13	GB1235-76	O 型圈 115 × 3.1 "O" Ring	1	
14	ZL40.3.2-4	壳体 Filter Shell	1	
15	GB5782-86	螺栓 M8 × 35 Bolt	4	
16	GB93-87	垫圈 8 Lock Washer	4	



# 21. 操纵系统(一) Control System(1)

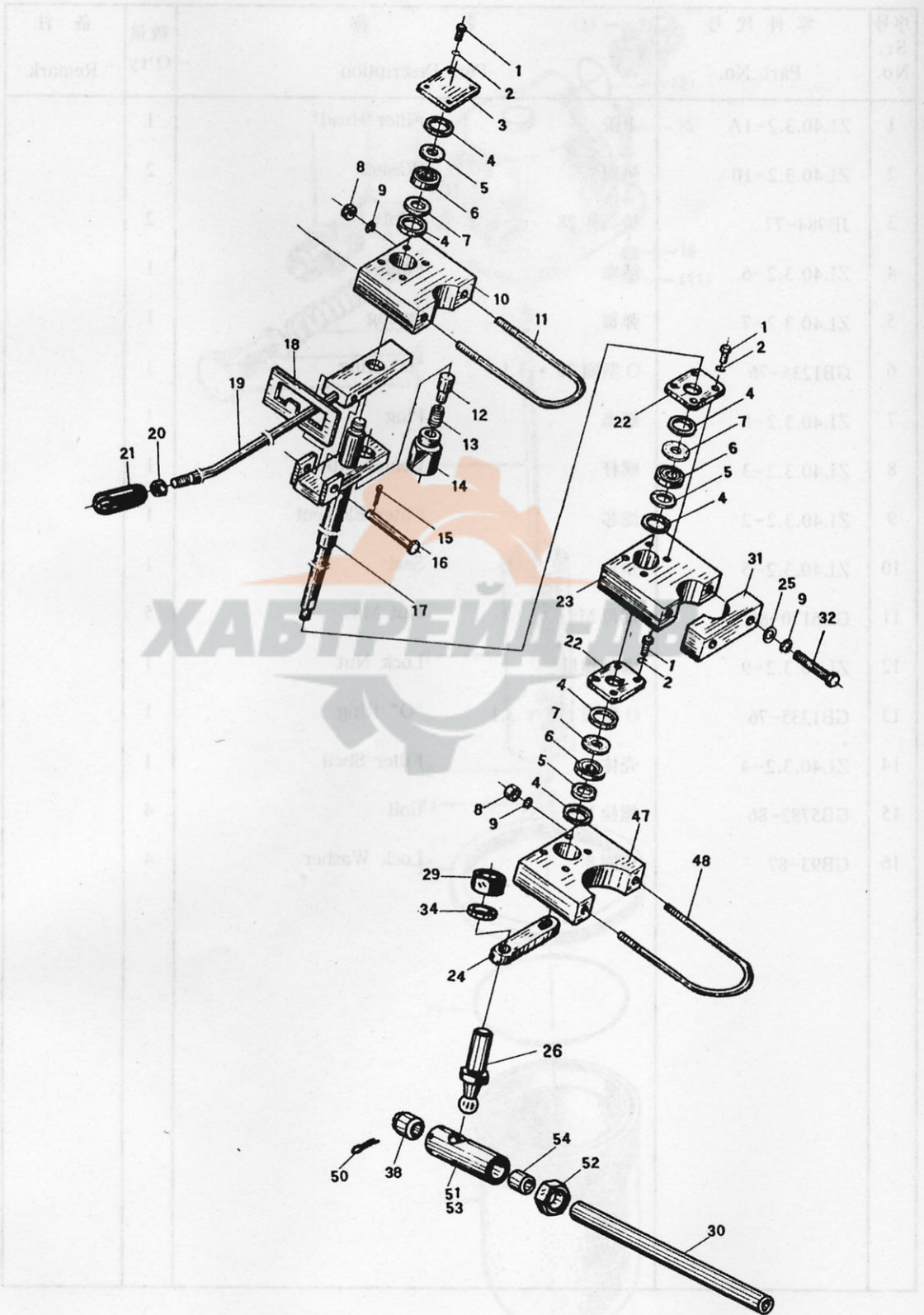

## 21. 操纵系统(二) Control System(2)

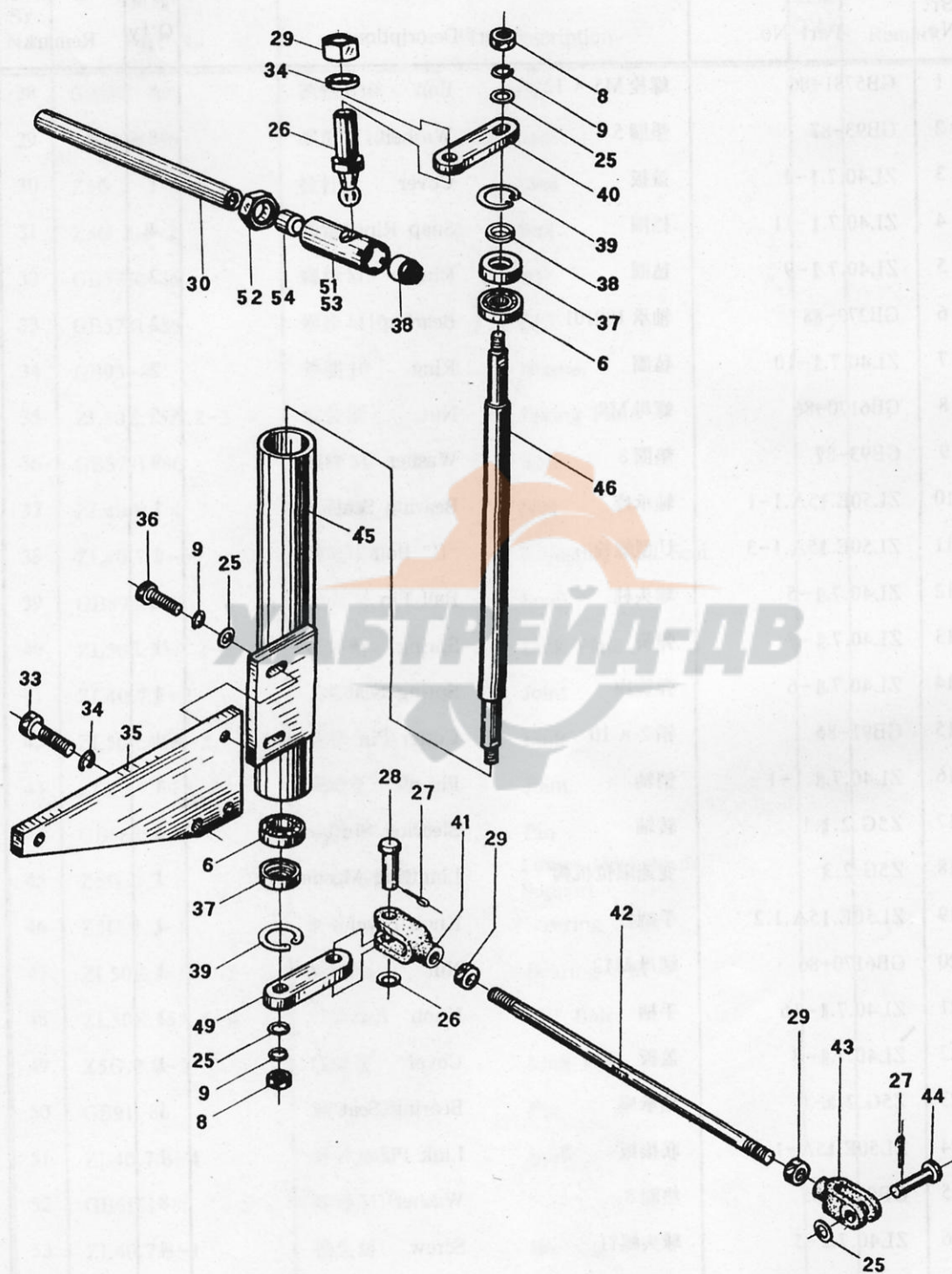



## 21.操纵系统 Control System

序号 Sr. No.	零件代号 Part No.	名称 Part Description	数量 Q'ty	备注 Remark
1	GB5781-86	螺栓 M5 × 12 Bolt	8	
2	GB93-87	垫圈 5 Washer	8	
3	ZL40.7.1-1	盖板 Cover	1	
4	ZL40.7.1-11	挡圈 Snap Ring	4	
5	ZL40.7.1-9	毡圈 Ring	2	
6	GB279-88	轴承 180101 Bearing	2	
7	ZL40.7.1-10	毡圈 Ring	2	
8	GB6170-86	螺母 M8 Nut	5	
9	GB93-87	垫圈 8 Washer	9	
10	ZL50E.15A.1-1	轴承座 Bearing Seat	1	
11	ZL50E.15A.1-3	U型螺栓 "U" Bolt	1	
12	ZL40.7.1-5	球头柱 Ball Pin	1	
13	ZL40.7.1-7	弹簧 Spring	1	
14	ZL40.7.1-6	弹簧座 Spring Seat	1	
15	GB91-86	销 2 × 10 Cotter Pin	1	
16	ZL40.7.1.1-1	销轴 Pin	1	
17	Z5G.2.1.1	转轴 Steering Shift	1	
18	Z5G.2.3	变速限位机构 Limiting Mechanism	1	
19	ZL50E.15A.1.2	手柄杆 Knob Lever	1	
20	GB6170-86	螺母 M12 Nut	1	
21	ZL40.7.1-16	手柄 Knob	1	
22	ZL40.7.1-8	盖板 Cover	1	
23	Z5G.2.1-1	轴承座 Bearing Seat	1	
24	ZL50E.15A-1	联接板 Link Plate	1	
25	GB97.1-85	垫圈 8 Washer	8	
26	ZL40.7.3-5	球头螺钉 Screw	4	
27	GB91-86	销 3.2 × 20 Cotter Pin	4	

## 21.操纵系统 Control System

序号 Sr. No.	零件代号 Part No.	名 称 Part Description		数量 Q'ty	备注 Remark
28	GB882-86	销轴 B10 × 32	Pin	3	
29	GB6170-86	螺母 M10	Nut	4	
30	Z5G.2-1	拉杆	Link	1	
31	Z5G.2.1-2	固定座	Seat	1	
32	GB5780-86	螺栓 M8 × 55	Bolt	2	
33	GB5781-86	螺栓 M10 × 35	Bolt	2	
34	GB93-87	垫圈 10	Washer	2	
35	ZL50E.15A.2-3	安装板	Fixing Plate	1	
36	GB5781-86	螺栓 M8 × 25	Bolt	2	
37	ZL40A.7.4-3	毛毡座	Seat	2	
38	ZL40.7.3-6	调整球座	Adjusting Ball Seat	4	
39	GB893.1-86	挡圈 28	Snap	2	
40	ZL50E.15A.2-2	联接板	Link Plate	2	
41	ZL40.7.5-2	叉接头 M10	Joint	3	
42	ZL50E.15A-5	联杆	Link	1	
43	ZL40.7.5-3	叉接头 M10-F 8	Joint	1	
44	GB882-86	销轴 B8 × 32	Pin	1	
45	Z5G.2.2.1	下部机构架	Lower Mechanism Support	1	
46	Z5G.2.2-1	转轴	Steering Shift	1	
47	ZL50E.15A.1-2	轴承座	Bearing Seat	1	
48	ZL50E.15A.1-4	U 型螺栓	"U" Bolt	1	
49	Z5G.2.2-2	联接板	Link Plate	1	
50	GB91-86	销 2 × 20	Pin	4	
51	ZL40.7.3-4	弹簧外套	Spring	4	
52	GB6171-86	螺母 M10 × 1	Nut	8	
53	ZL40.7.3-1	接头套	Bushing	4	
54	ZL40.7.3-3	球面座	Ball Seat	4	



## 22. 工作装置 Working Device

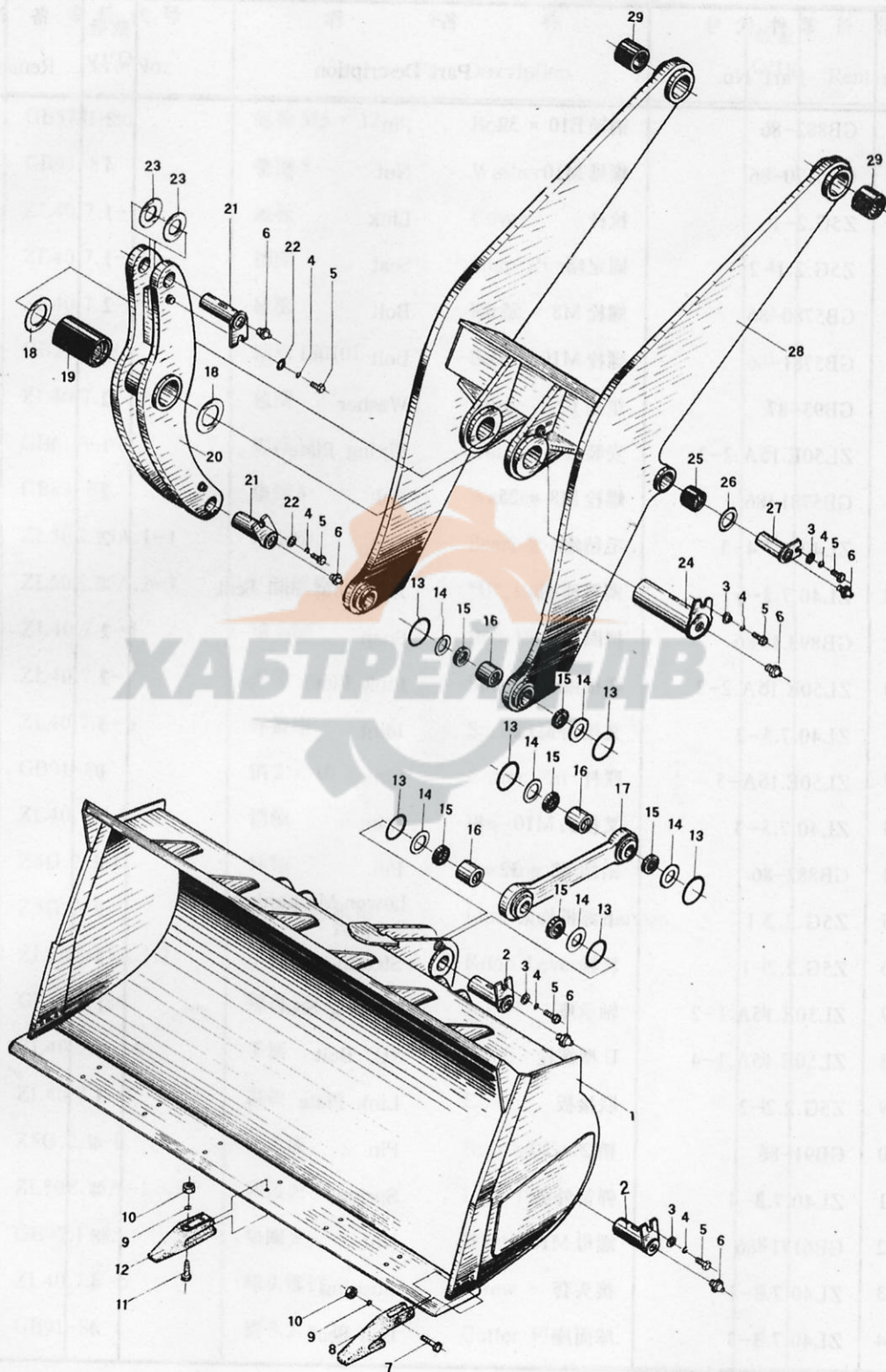

## 22.工作装置 Working Device

序号 Sr. No.	零件代号 Part No.	名 称 Part Description	数量 Q'ty	备 注 Remark
1	Z5G.8.1E	铲斗总成 Bucket	1	
2	Z5G.8.7	铲斗销 Shaft Pin	3	
3	85Z.06-5	垫圈 Washer	6	
4	GB93-87	垫圈 16 Washer	8	
5	GB5783-86	螺栓 M16 × 25 Bolt	8	
6	GB1152-89	油杯 M10 × 1 Grease Nipple	8	
7	GB5782-86	螺栓 M20 × 100 Bolt	4	
8	Z5G.8.1-1	边齿 Bucket Tooth	2	
9	GB93-87	垫圈 20 Washer	16	
10	ZL40A.11.1-19	螺母 Nut	16	
11	Z5G.8.1-2	螺栓 Bolt	12	
12	ZL40A.11.1-18B	铲斗齿 Bucket Tooth	6	
13	Z5G.8-5	O形圈 "O" Ring	8	
14	ZL50E.6-19	调整垫片 Adjusting Cushion	15	
15	GB9877.1-88	骨架油封 B80 × 100 × 10 Skeleton Oil Seal	8	
16	Z5G.8-6A	轴套 Shaft Bushing	4	
17	Z5G.8.3	拉杆 Link	1	
18	ZL50E.8-12	调整垫片 Adjusting Cushion	4	
19	Z5G.8-2	轴套 Shaft Bushing	1	
20	Z5G.8.4	摇臂 Pitman Arm	1	
21	Z5G.8.6	摇臂油缸销 Shaft Pin	2	
22	ZL50E.8-4	垫块 Block	2	
23	ZL50E.6-19	调整垫片 Adjusting Cushion	15	
24	Z5G.8.5	摇臂梁销 Shaft Pin	1	
25	Z5G.8-1	轴套 Shaft Bushing	2	
26	ZL50E.8-16	垫片 Washer	8	
27	ZL50E.8.7	动臂油缸销 Shaft Pin	2	
28	Z5G.8.2	动臂 Lift Arm	1	
29	Z5G.8-3	轴套 Shaft Bushing	2	



# 23. 前车架 Front Chassis

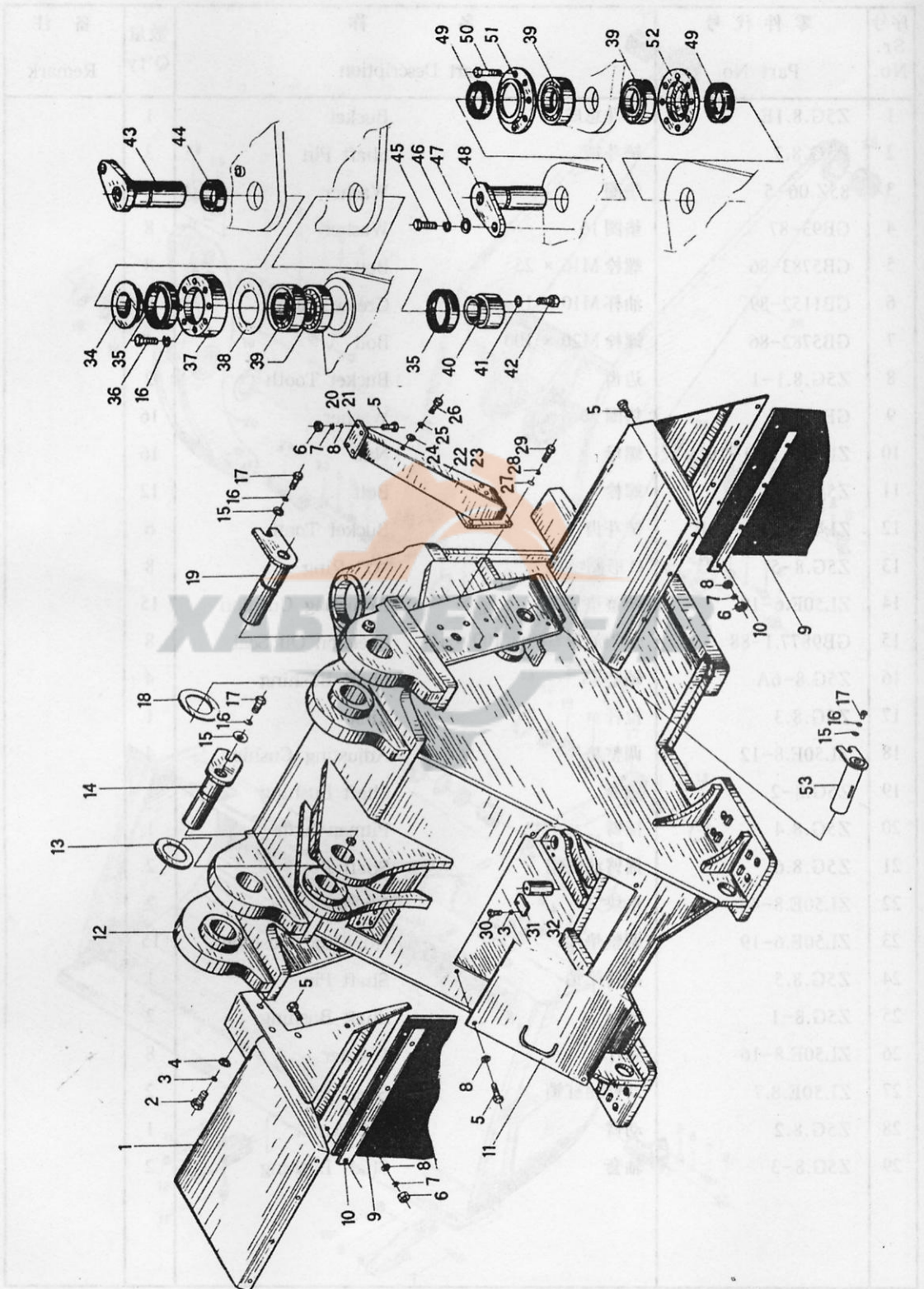

## 23.前车架 Front Chassis

序号 Sr. No.	零件代号 Part No.	名 称 Part Description	数量 Q'ty	备注 Remark
1	Z5G.6.18	左挡泥板	1	
	Z5G.6.19	右挡泥板	1	
2	GB5783-86	螺栓 M12 × 30	8	
3	GB93-87	垫圈 12	24	
4	GB97.1-85	垫圈 12	24	
5	GB5781-86	螺栓 M8 × 20	16	
6	GB6170-86	螺母 M8	8	
7	GB93-87	垫圈 8	8	
8	GB96-85	垫圈 8	12	
9	Z5G.6.18-2	胶垫	2	
10	Z5G.6.18-1	安装板	2	
11	Z5G.6.20	前罩板	1	
12	Z5G.6.1	前车架	1	
13	ZL50E.6-19	调整垫片	1组	
14	Z5G.6.21	转斗缸车架销	1	
15	85Z.06-5	垫圈	5	
16	GB93-87	垫圈 16		
17	GB5783-86	螺栓 M16 × 25		
18	ZL50E.6-17	调整垫片	2组	
19	Z5G.6.4	动臂-车架销	2	
20	Z5G.6.16	左灯架	1	
21	Z5G.6.17	右灯架	1	
22	Z5G.6.16-1	左盖板	1	
23	Z5G.6.17-1	右盖板	1	
24	GB97.1-85	垫圈 6	6	
25	GB93-87	垫圈 6	6	
26	GB5781-86	螺栓 M6 × 16	6	
27	GB97.1-85	垫圈 10	8	
28	GB93-87	垫圈 10	8	
29	GB5783-86	螺栓 M10 × 35	8	
30	GB5783-86	螺栓 M12 × 30	2	
31	Z5G.6-15	卡板	2	



## 23.前车架 Front Chassis

序号 Sr. No.	零件代号 Part No.	名 称 Part Description	数量 Q'ty	备注 Remark
32	ZL50.8-6	后转向销 Shaft Pin	2	
34	85Z.06.14-1	隔套 Slave	1	
35	GB9877.1-88	密封圈B100 × 125 × 12 Skeleton Oil Seal	2	
36	GB5782-86	螺栓 M16 × 55 Bolt	8	
37	ZL50E.6-3	轴承盖 Bearing Cap	1	
38	85Z.06.14-3	调整垫片 Adjusting Cushion	1组	
39	GB297-84	轴承 7517E Bearing	4	
40	ZL50E.6-2	下盖 Cover	1	
41	85Z.06.14-6	垫片 Washer	4	
42	85Z.06.14-5	螺栓 Bolt	4	
43	ZL50E.6.10	上铰接销 Shaft Pin	1	
44	85Z.07.1.2.1-11	轴套 Pin Slave	1	
45	GB5783-86	螺栓 M20 × 40 Bolt	5	
46	GB93-87	垫圈 20 Washer	5	
47	ZL50E.6-4	垫圈 Washer	1	
48	Z5G.6.13	下铰接销 Center Pin	1	
49	GB9877.1-88	密封圈 B85 × 120 × 12 Skeleton Oil Seal	2	
50	GB5782-86	螺栓 M12 × 100 Bolt	12	
51	Z5G.6-10	下销上法兰 Flange	1	
52	Z5G.6-11	下销下法兰 Flange	1	
53	Z5G.6.3	动臂缸 - 车架销 Shaft Pin	2	

# 24.后车架总成 Rear Chassis Group

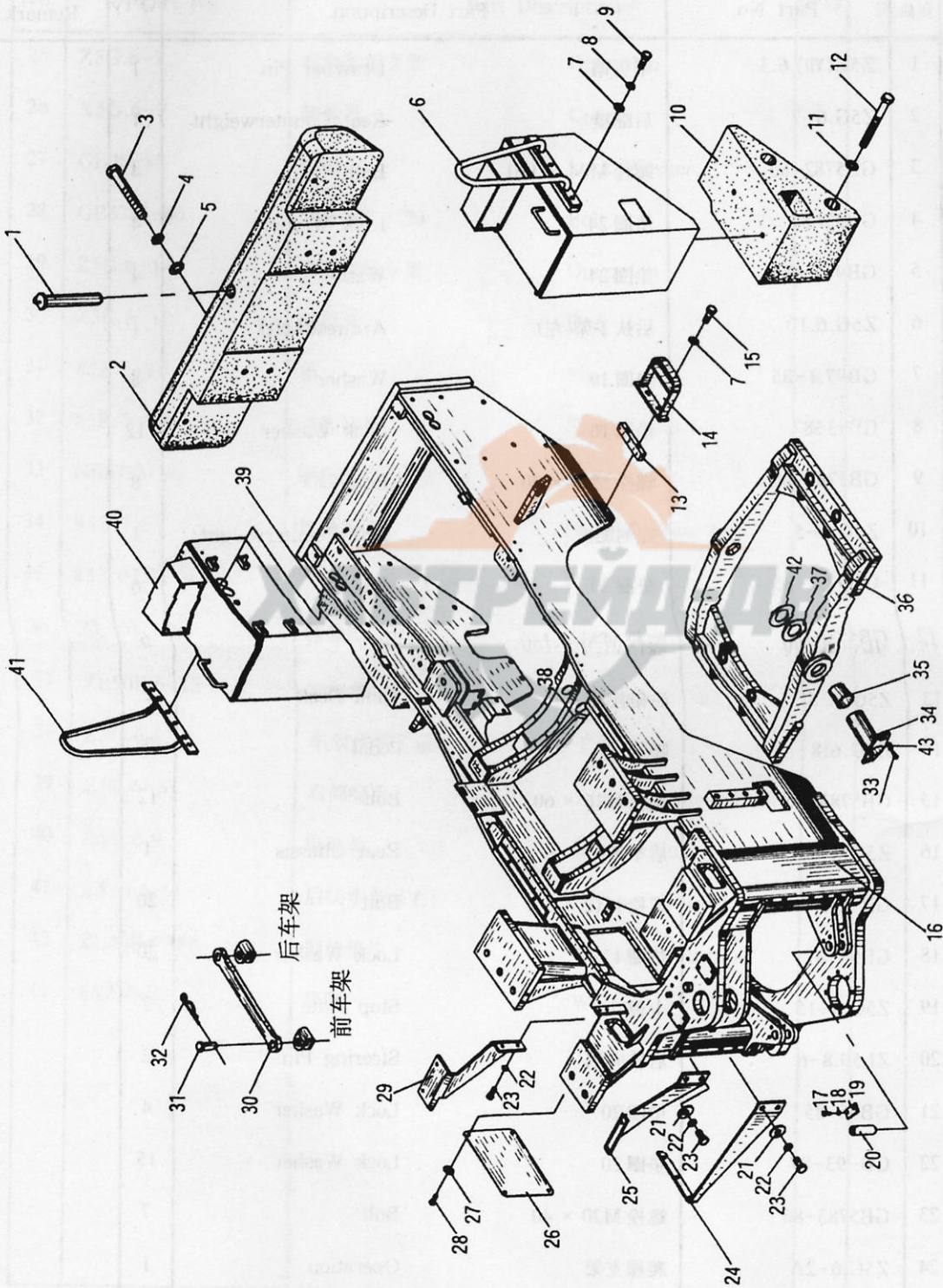



## 24.后车架总成 Rear Chassis Group

序号 Sr. No.	零件代号 Part No.	名称 Part Description	数量 Q'ty	备注 Remark
1	Z5G(VII).6.3	牵引销 Drawbar Pin	1	
2	Z5G.6-7	后配重 Rear Counterweight	1	
3	GB5782-86	螺栓 M24 × 180 Bolt	4	
4	GB93-87	垫圈 24 Lock Washer	4	
5	GB97.1-85	垫圈 24 Washer	4	
6	Z5G.6.10	后扶手架(左) Armrest(Left)	1	
7	GB97.1-85	垫圈 16 Washer	8	
8	GB93-87	垫圈 16 Lock Washer	12	
9	GB5783-86	螺栓 M16 × 40 Bolt	8	
10	Z5G.6-5	左侧配重 Left Counterweight	1	
11	GB97.1-85	垫圈 20 Washer	6	
12	GB5782-86	螺栓 M20 × 180 Bolt	6	
13	Z5G.6-8	油箱托架 Tank Deck	2	
14	Z5G.6.8	脚踏 Pedal	2	
15	GB5783-86	螺栓 M16 × 60 Bolt	12	
16	Z5G(V).6.2	后车架 Rear Chassis	1	
17	GB5783-86	螺栓 M12 × 30 Bolt	20	
18	GB93-87	垫圈 12 Lock Washer	20	
19	Z5G.6-15	卡板 Stop Plate	2	
20	ZL50.8-6	后转向销 Steering Pin	2	
21	GB96-85	垫圈 20 Lock Washer	4	
22	GB-93-87	垫圈 20 Lock Washer	15	
23	GB5783-86	螺栓 M20 × 40 Bolt	7	
24	Z5G.6-2A	爬梯支架 Operation	1	

24.后车架总成 Rear Chassis Group

序号 Sr. No.	零件代号 Part No.	名 称 Part Description	数量 Q'ty	备 注 Remark
25	Z5G.6-1	右台架前支架 Operation	1	
26	X5G.6-9	侧盖板 Cover	1	
27	GB96-85	垫圈 8 Lock Washer	8	
28	GB5783-86	螺栓 M8 × 20 Bolt	4	
29	Z5G.6-14	右台架后支架 Operation	1	
30	Z5G.6-12	固定杆 Rod	1	
31	85Z.7-14	销 Pin	2	
32	85Z.7-15	弹性挡簧 Spring Split	2	
33	GB5783-86	螺栓 M16 × 25 Bolt	4	
34	85Z.7.0	摆动架销 Sway Carcase Pin	2	
35	85Z.07.11-4	套 Pipe	2	
36	ZL50E.6.6	摆动架 Sway Carcase	1	
37	ZL50E.6-15	调整垫片 Adjusting Cushion	2	
38	Z5G.6.12	车架注油管总成 Tube	1	
39	Z5G.6-6	右侧配重 Right Counterweight	1	
40	Z5G.6.9	电瓶箱 Battery Box	2	
41	Z5.G.6.11	后扶手架 (右) Armrest (Right)	1	
42	ZL50E.6-14	调整垫片 Adjusting Cushion	2	
43	85Z.7-3	垫圈 Washer	4	



## 25. 左右台架 Left Right Platform

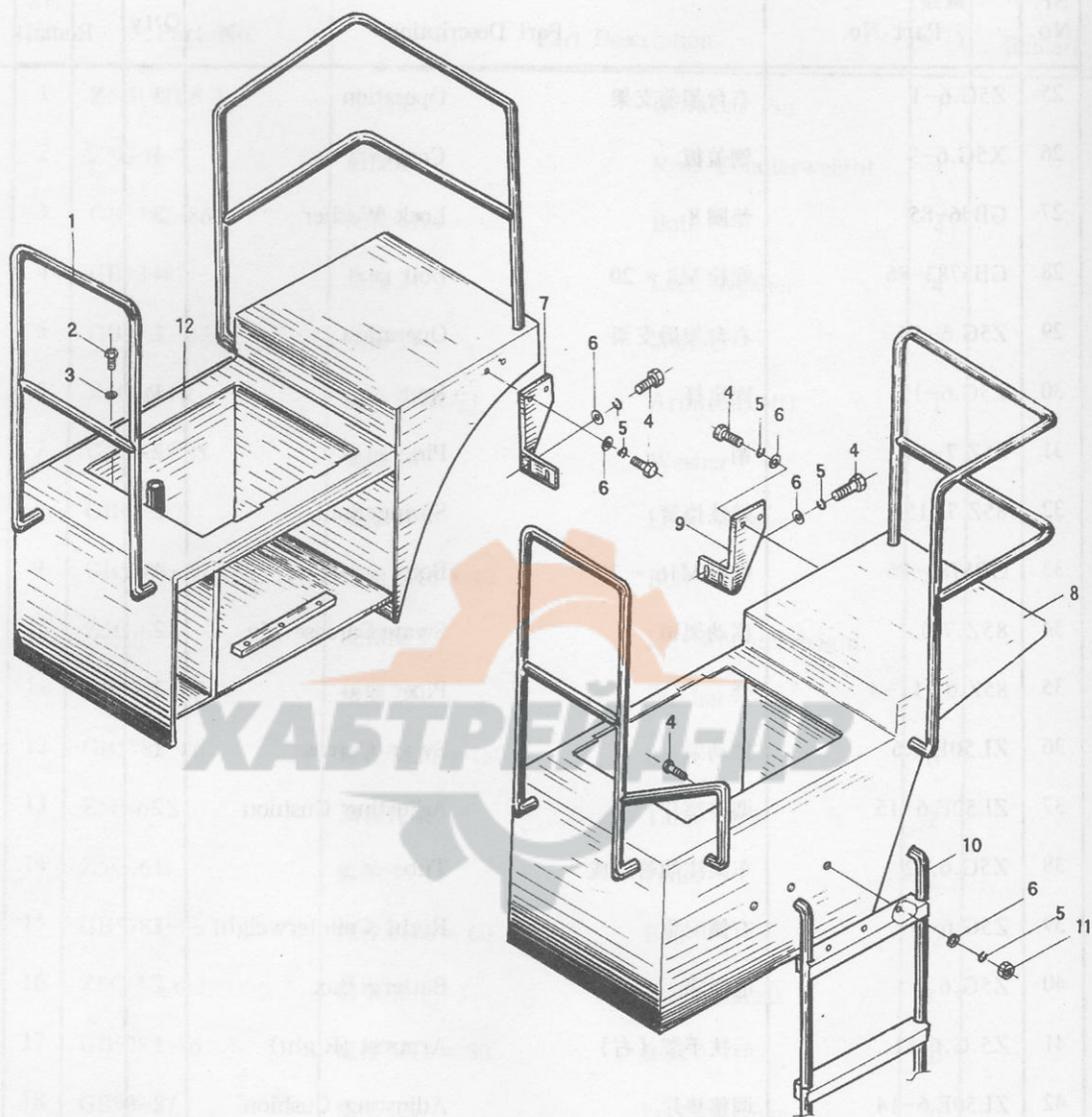

## 25.左右台架 Left Right Platform

序号 Sr. No.	零件代号 Part No.	名 称 Part Description	数量 Q'ty	备注 Remark
1	Z5G.6.15B	右台架 Right Platform	1	
2	GB5781-86	螺栓 M5 × 12 Bolt	4	
3	GB97.1-85	垫圈 5 Washer	4	
4	GB5783-86	螺栓 M12 × 30 Bolt	8	
5	GB93-87	垫圈 12 Washer	14	
6	GB97.1-85	垫圈 12 Washer	14	
7	Z5G.6-3	右台架固定板 Plate	1	
8	Z5G.6.14A	左台架 Left Platform	1	
9	Z5G.6-4	左台架固定板 Plate	1	
10	Z5G.6.5B	右爬梯 Right Ladder	1	
11	GB6170-86	螺母 M12 Nut	6	
12	Z5G.6.5C	左爬梯 Left Ladder	1	



# 26. 电瓶箱 Battery Box

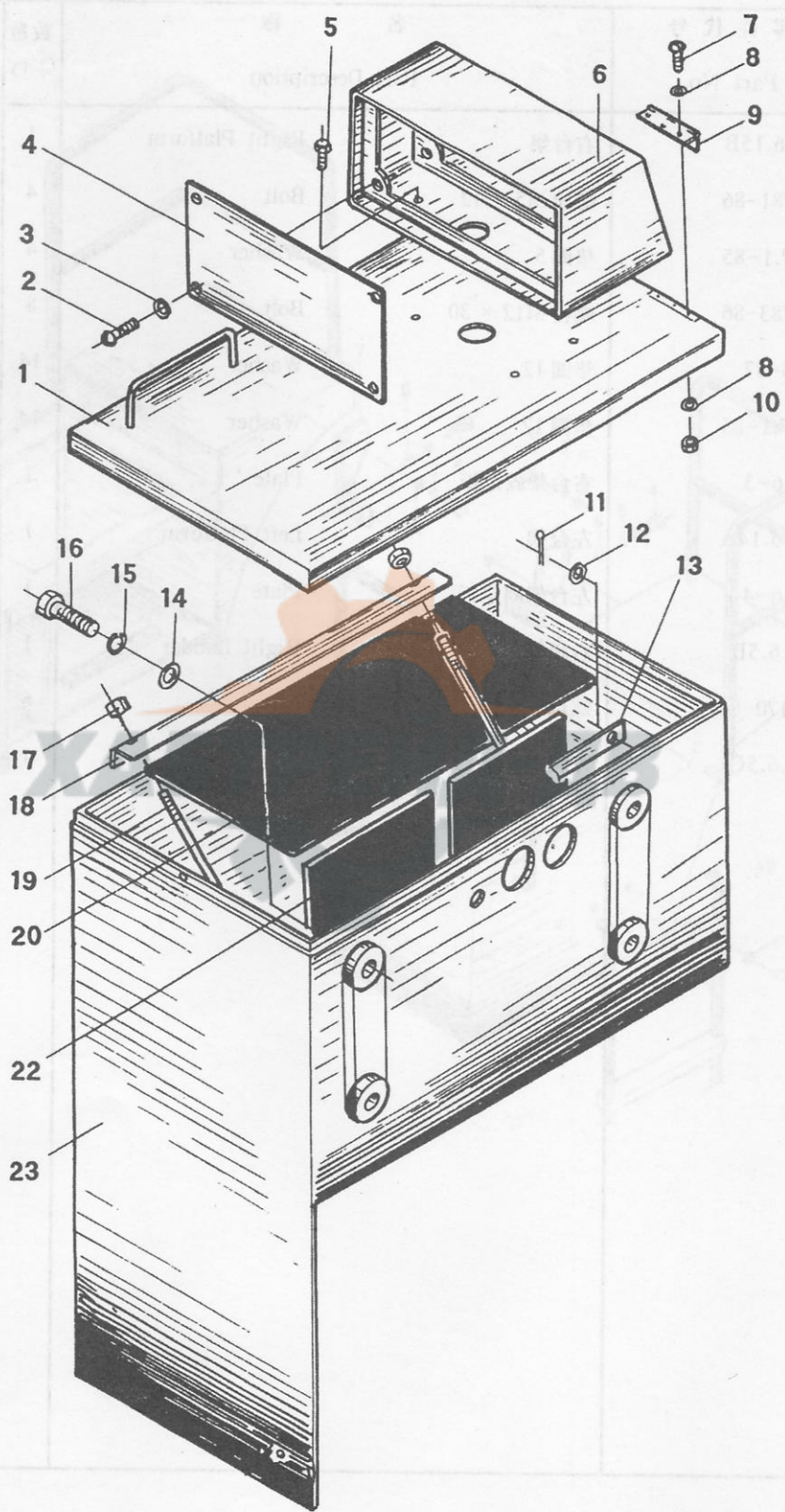

## 26. 电瓶箱 Battery Box

序号 Sr. No.	零件代号 Part No.	名称 Part Description	数量 Q'ty	备注 Remark
1	Z5G.6.9.1A Z5G.6.9.2A	箱盖 Cover	各1	
2	GB67-85	螺钉 M5 × 12 Screw	8	
3	GB97.1-85	垫圈 5 Washer	8	
4	Z5G.6-9-1	灯后盖 Cover	2	
5	GB5783-86	螺栓 M8 × 16 Bolt	8	
6	Z5G.6.9.3	灯架 Lamp Protector	2	
7	GB67-85	螺钉 M4 × 10 Screw	12	
8	GB97.1-85	垫圈 4 Washer	24	
9		普通铰链 75 Gemel	2	
10	GB6170-86	螺母 M4 Nut	12	
11	GB91-86	开口销 2 × 20 Cotter Pin	2	
12	GB97.1-85	垫圈 8 Washer	2	
13	Z5G.6.8.6	撑杆 Sustain Rod	2	
14	GB97.1-85	垫圈 16 Washer	4	
15	GB93-87	垫圈 16 Washer	4	
16	GB5783-86	螺栓 M16 × 60 Bolt	4	
17	FB6170-86	螺母 M8 Nut	4	
18	ZL40.18.5-2	锁紧角钢 Angle Iron	2	
19	ZL40A.18.5-4	锁紧螺杆 Screw Rod	4	
20	ZL40A.18.5-5	橡胶板 Rubber Pad	2	
22	ZL40A.18.5-3	橡胶垫 Rubber Pad	8	
23	Z5G.6.9.4A 右 Z5G.6.9.5A 左	电瓶箱框 Battery Box	1	



## 27. 车架注油管总成 Grease Pipe Assem

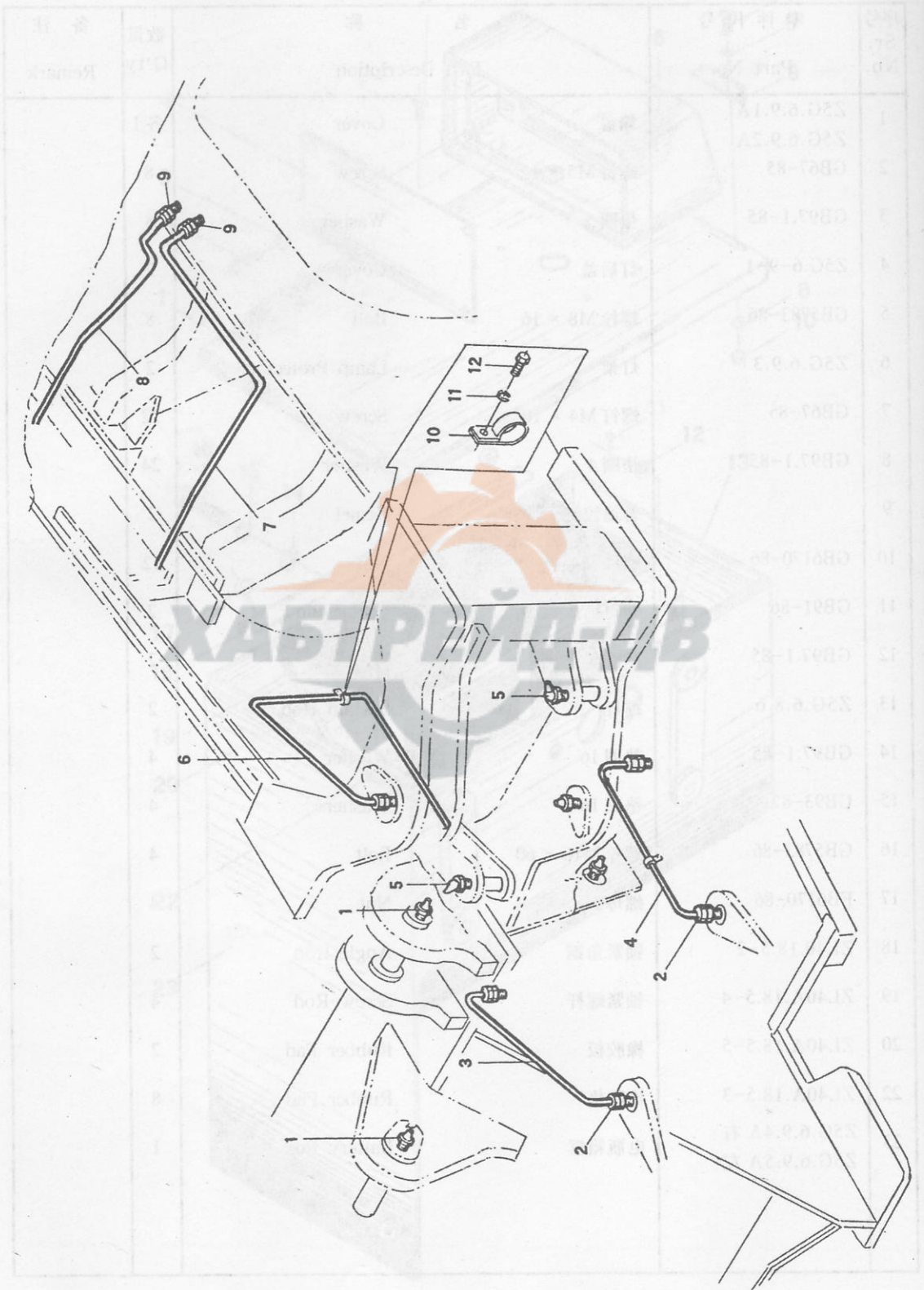

27.车架注油管总成 Grease Pipe Assem

序号 Sr. No.	零件代号 Part No.	名称 Part Description	数量 Q'ty	备注 Remark
1	GB1152-79	油杯 M10 × 1 Grease Cover	11	
2	GB5625.2-85	接头体 6 Connector	8	
3	ZL50E.6.9.4	右转向座油管 Tube	2	
4	ZL50E.6.9.5	左转向座油管 Tube	2	
5	GB1153-79	油杯 M10 × 145° Grease Cover	2	
6	Z5G.6.12.1	上铰接销注油管 Tube	1	
7	Z5G.6.12.2	前支架注油管 Tube	1	
8	Z5E.6.12.3	后支架注油管 Tube	1	
9	GB5631.2-85	接头体 6 Connector	4	
10	ZL40.8-19	管夹 Pipe-Clmper	13	
11	GB93-87	垫圈 8 Washer	13	
12	GB5783-86	螺栓 M8 × 16 Bolt	13	



# 28. 工作液压系统 Working Hydraulic System

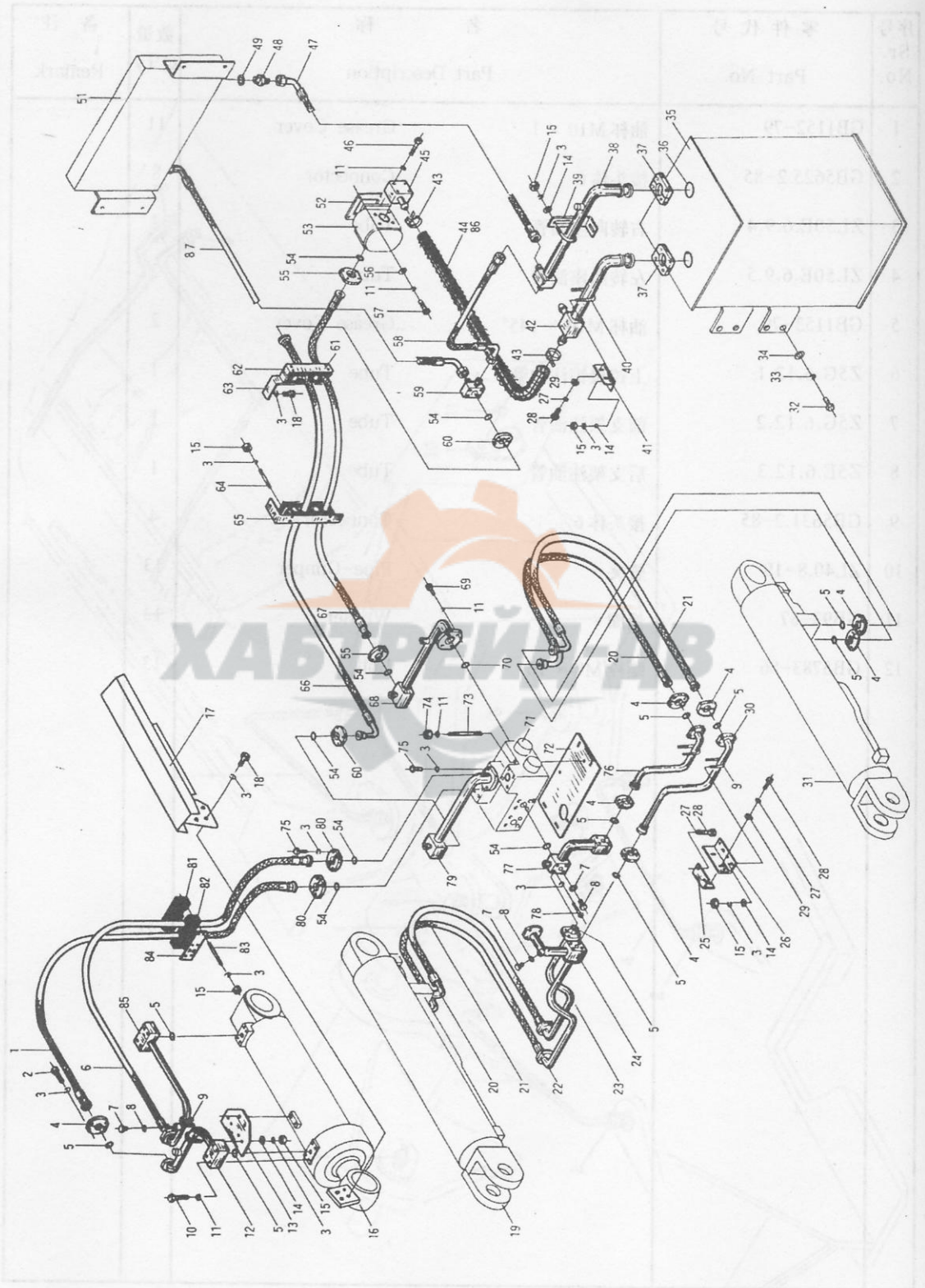

28.工作液压系统 Working Hydraulic System

序号 Sr. No.	零件代号 Part No.	名称 Part Description	数量 Q'ty	备注 Remark
1	Z5G.7.1.5	F型胶管 "F" Hose	1	
2	GB5783-86	螺栓 M10 × 30 Bolt	56	
3	GB93-87	垫圈 10 Lock Washer	134	
4	85Z.10.1-2	分离式法兰 Split Flange	14	
5	GB3452.1-82	O型密封圈 30 × 3.55 "O" Ring	10	
6	Z5G.7.1.6	F型胶管 "F" Hose	1	
7	Z5G.7.1-1	螺塞 Plug	6	
8	JB982-77	垫圈 14 Ring	6	
9	85Z.10.1.1-2	U形螺栓 "U" Bolt	6	
10	GB5782-86	螺栓 M12 × 70 Bolt	8	
11	GB93-87	垫圈 12 Lock Washer	39	
12	Z5G.7.1.2	钢管 Tube	1	
13	ZL50E.7.1-1	固定板 Plank	1	
14	GB97.1-85	垫圈 10 Washer	16	
15	GB6170-86	螺母 M10 Nut	38	
16	Z5G.7.1.1	转斗油缸 Cylinder	1	
17	Z5G.7.1.31	护罩 Cover	1	
18	GB5783-86	螺栓 M10 × 25 Bolt	14	
19	Z5G.7.1.3A	右动臂油缸 Cylinder	1	
20	Z5G.7.1.19	F型胶管 "F" Hose	2	
21	Z5G.7.1.18	F型胶管 "F" Hose	2	
22	Z5G.7.1.7	钢管 Tube	1	
23	Z5G.7.1.8	钢管 Tube	1	
24	Z5G.7.1.9	钢管 Tube	1	
25	Z5G.7.1-15	支板 Plank	2	
26	Z5G.7.1-2	支板 Plank	2	
27	GB93-87	垫圈 8 Lock Washer	10	
28	GB5783-86	螺栓 M8 × 25 Bolt	10	
29	GB97.1-87	垫圈 8 Washer	6	
30	Z5G.7.1.22	钢管 Tube	1	
31	Z5G.7.1.24A	左动臂油缸 Cylinder	1	



## 28. 工作液压系统 Working Hydraulic System

序号 Sr. No.	零件代号 Part No.	名 称 Part Description	数量 Q'ty	备 注 Remark
32	GB5783-86	螺栓 M20 × 40 Bolt	8	
33	GB93-87	垫圈 20 Lock Washer	8	
34	GB97.1-85	垫圈 20 Washer	8	
35	Z5G.7.1.27	液压油箱 Oil Box	1	
36	GB3452.1-82	O 形密封圈 61.5 × 3.55 "O" Ring	3	
37	ZL50E.7.1.24-1	分离式法兰 Split Flange	2	
38	Z5G.7.1.16B	钢管 Tube	1	
39	Z5G.7.1-6	支板 Plank	1	
40	Z5G.7.1-7	U 形螺栓 "U" Bolt	2	
41	Z5G.7.1-8	支板 Plank	1	
42	Z5G.7.1.17A	钢管 Tube	1	
43	ZBJ15001-87	喉箍 d60 Clamp	2	
44	Z5G.7.1-9	软管 Hose	1	
45	Z5G.7.1.14A	接头块 Connector	1	
46	GB5782-86	螺栓 M12 × 80 Bolt	4	
47	Z5G.7.1.13A	D 形胶管 "D" Tube	1	
48	Z5G.7.1-13	接头 Connector	2	
49	JB982-77	垫圈 27 Ring	2	
51	Z5G.7.1.28	液压油散 Oil Radiator	1	
52	85Z II.7.1-4	密封垫 Ring	1	
53	GBGj3100/1010	双联齿轮泵 Gear Pump	1	
54	GB3452.1-82	O 型密封圈 40 × 3.55 "O" Ring	8	
55	85Z.10.1-6	分离式法兰 Split Flange	2	
56	GB97.1-85	垫圈 12 Washer	8	
57	GB5782-86	螺栓 M12 × 45 Bolt	8	
58	Z5G.7.1.15A	D 型胶管 "D" Hose	1	
59	Z5G.7.1.26C	接头块 Connector	1	
60	Z5G.7.1-5	分离式法兰 Split Flange	2	
61	Z5G.7.1.29-2	夹板 Plate	2	
62	Z5G.7.1.29-1	橡胶夹板 Plate	4	
63	Z5G.7.1-12	支板 Plank	1	

28.工作液压系统 Working Hydraulic System

序号 Sr. No.	零件代号 Part No.	名 称 Part Description	数量 Q'ty	备 注 Remark
64	GB901-88	螺栓 M10 × 90 Bolt	8	
65	Z5G.7.1-11	支板 Plank	1	
66	Z5G.7.1.25	F 型胶管 "F" Hose	1	
67	Z5G.7.1.12C	F 型胶管 "F" Hose	1	
68	Z5G.7.1.11	钢管 Tube	1	
69	GB5783-86	螺栓 M12 × 35 Bolt	20	
70	GB3452.1-82	O 型密封圈 50 × 3.55 "O" Ring	2	
71	D32	多路阀 Valve	1	
72	Z5G.7.1-10	安装板 Plank	1	
73	GB901-88	螺柱 M12 × 180 Bolt	3	
74	GB6170-86	螺母 M12 Nut	3	
75	GB5782-86	螺栓 M10 × 35 Bolt	32	
76	Z5G.7.1.20	钢管 Tube	1	
77	Z5G.7.1.23	钢管 Tube	1	
78	GB5782-86	螺栓 M10 × 70 Bolt	4	
79	Z5G.7.1.21	钢管 Tube	1	
80	Z5G.7.1-4	分离式法兰 Split Flange	2	
81	Z5G.7.1.10-3	下板 Plate	1	
82	Z5G.7.1.10-2	上板 Plate	1	
83	GB901-88	螺柱 M10 × 110 Bolt	6	
84	Z5G.7.1.10-1	压板 Plate	1	
85	Z5G.7.1.4	钢管 Tube	1	
86	ZL50E.7.1-10	弹簧 Spring	1	
87	Z5G.7.1.30	D 型胶管 "D" Hose	1	



## 29. 转向液压系统 Steering Hydraulic System

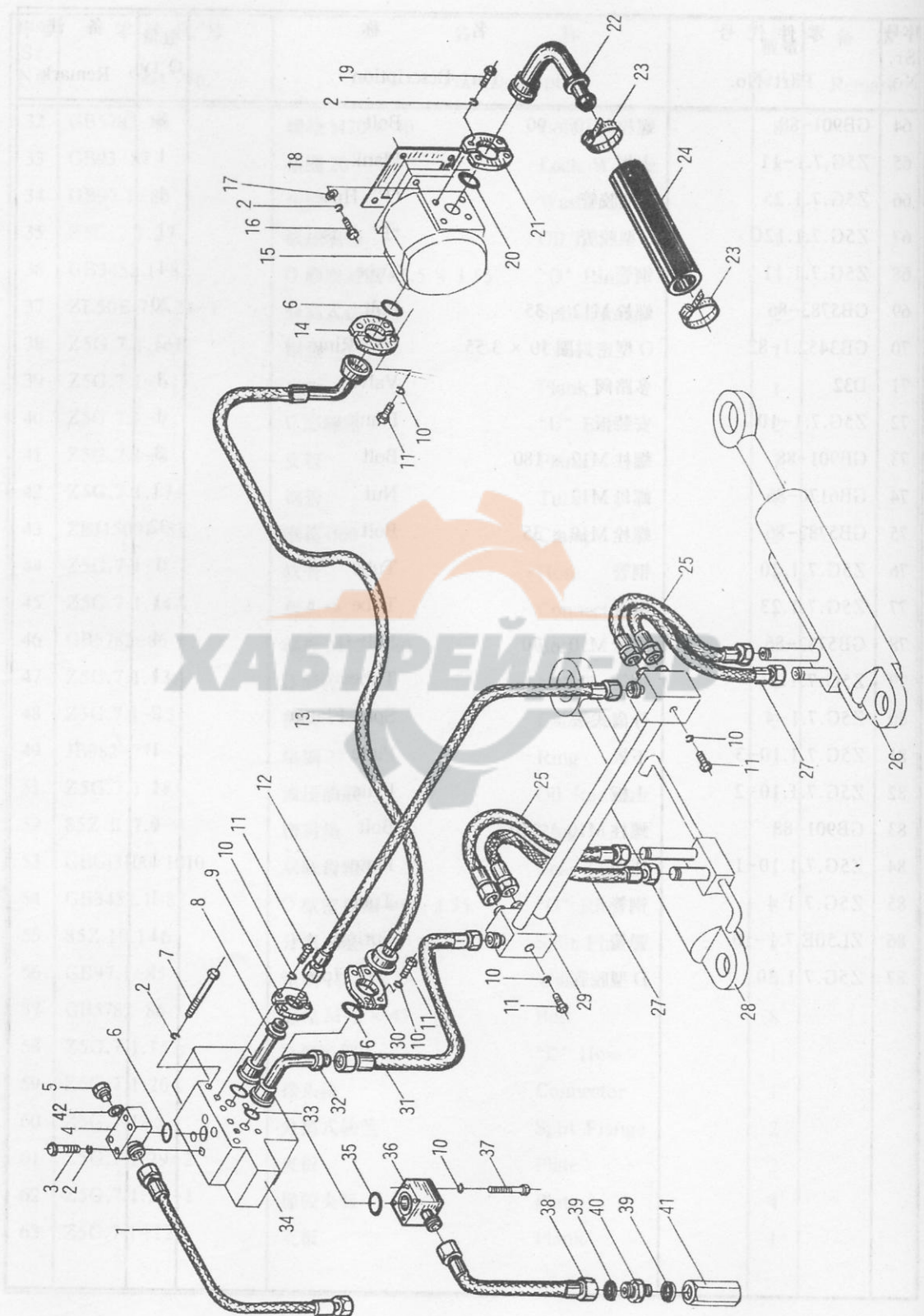

## 29.转向液压系统 Steering Hydraulic System

序号 Sr. No.	零件代号 Part No.	名 称 Part Description	数量 Q'ty	备 注 Remark
1	Z5G.7.2.1	高压软管总成 High Pressure Hose	1	
2	GB93-87	垫圈 12 Washer	19	
3	GB5782-86	螺栓 M12 × 55 Bolt	4	
4	ZL50F.7.2.1	回油块 Back Oil Block	1	
5	Z5G.7.1-1	螺塞 Plug	2	
6	GB3452.1-82	O 型圈 40 × 3.55 "O" Ring	3	
7	GB5782-86	螺栓 M12 × 110 Bolt	3	
8	Z5G.7.2.4	接管 II Joint Tube	1	
9	Z5G.7.1-4	分离式法兰 Split Flange	2	
10	GB93-87	垫圈 10 Washer	14	
11	GB5783-86	螺栓 M10 × 25 Bolt	14	
12	Z5G.7.2.10	高压软管总成 High Pressure Hose	1	
13	Z5G.7.2.6A	高压软管总成 High Pressure Hose	1	
14	85Z.10.1-6	分离式法兰 Split Flange	1	
15	CBGj2080	转向泵 Steering Gear Pump	1	
16	GB5781-86	螺栓 M12 × 45 Bolt	4	
17	GB97.1-85	垫圈 12 Washer	4	
18	85Z II.7.1-4	密封垫 Packing	1	
19	GB5781-86	螺栓 M12 × 30 Bolt	4	
20	GB3452.1-82	O 型圈 47.5 × 3.55 "O" Ring	1	
21	Z5G.7.2-3	分离式法兰 Split Flange	1	
22	Z5G.7.2.5	吸烟钢管 Inlet Oil Tube	1	
23	JB3616.1-84	喉箍 d60 Clamp	2	
24	Z5G.7.2-2	低压输油胶管 Low Pressure Hose	1	



## 29.转向液压系统 Steering Hydraulic System

序号 Sr. No.	零件代号 Part No.	名 称 Part Description		数量 Q'ty	备 注 Remark
25	Z5G.7.2.7	高压软管总成	High Pressure Hose	2	
26	ZL50E.7.2.7B	左转向缸	Left Steering Cylinder	1	
27	Z5G.7.2.8	高压软管总成	High Pressure Hose	2	
28	ZL50E.7.2.3B	右转向缸	Right Steering Cylinder	1	
29	ZL40E.9.15A	连接块总成	Join Block	1	
30	85Z.10.1-1S	分离式法兰	Split Flange	1	
31	Z5G.7.2.9	高压软管总成	High Pressure Hose	1	
32	Z5G.7.2.3	接管 I	Join Hose	1	
33	GB3452.1-82	O 型圈 30 × 3.55	"O" Ring	2	
34	ZLF25A1	优先型流量放大器	Supporting Block	1	
35	GB3452.1-82	O 型圈 32.5 × 3.55	"O" Ring	1	
36	Z5G.7.2.11	接头块	Join Block	1	
37	GB5780-86	螺栓 M10 × 75	Bolt	4	
38	Z5G.7.2.2	高压软管总成	High Pressure Hose	1	
39	JB982-77	密封垫 27	Packing	2	
40	Z5G.7.2-1	接头	Joint	1	
41	S15A312	单向阀	In-Line Check Valves	1	
42	JB982-77	密封垫 14	Packing	1	

# 30. 先导液压系统 Polit Hydraulic System

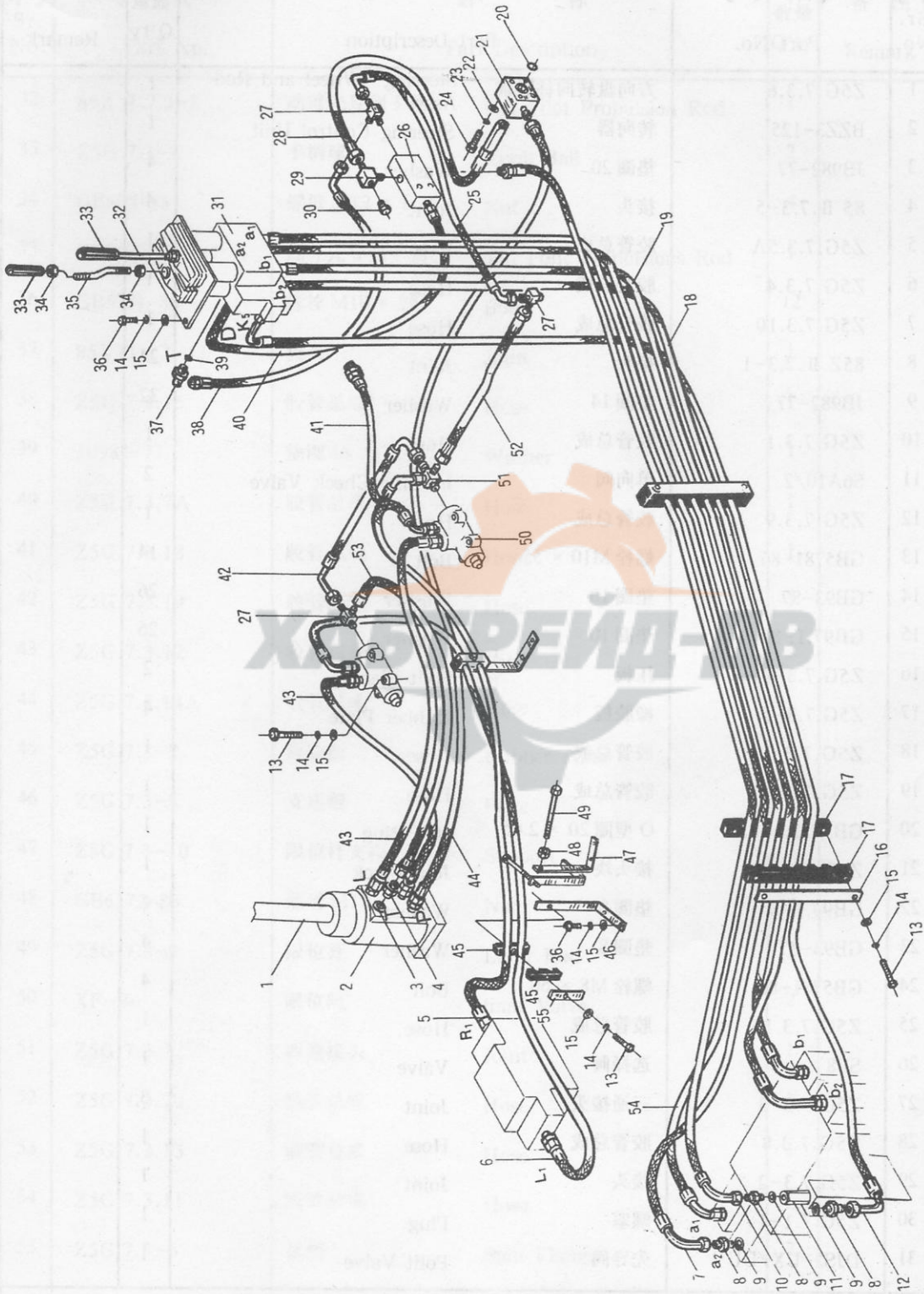



### 30.先导液压系统 Polit Hydraulic System

序号 Sr. No.	零件代号 Part No.	名 称 Part Description	数量 Q'ty	备 注 Remark
1	Z5G.7.3.6	方向盘转向柱总成 Steering Wheel and Rod Assy	1	
2	BZZ3-125	转向器 Steering Control Unit	1	
3	JB982-77	垫圈 20 Washer	4	
4	85 II.7.3-5	接头 Joint	4	
5	Z5G.7.3.5A	胶管总成 Hose	1	
6	Z5G.7.3.4	胶管总成 Hose	1	
7	Z5G.7.3.10	胶管总成 Hose	1	
8	85Z II.7.3-1	接头 Joint	24	
9	JB982-77	垫圈 14 Washer	32	
10	Z5G.7.3.1	胶管总成 Hose	1	
11	S6A10/2	单向阀 In-Line Check Valve	2	
12	Z5G.7.3.9	胶管总成 Hose	1	
13	GB5781-86	螺栓 M10 × 55 Bolt	14	
14	GB93-87	垫圈 10 Washer	26	
15	GB97.1-85	垫圈 10 Washer	26	
16	Z5G.7.3-4	压板 Split Flange	2	
17	Z5G.7.3-5	橡胶板 Rubber Plate	4	
18	Z5G.7.3.2	胶管总成 Hose	1	
19	Z5G.7.3.3	胶管总成 Hose	1	
20	GB3452.1-82	O 型圈 20 × 2.65 "O" Ring	1	
21	Z5G.7.3.17	接头块 Join Block	1	
22	GB97.1-85	垫圈 8 Washer	4	
23	GB93-87	垫圈 8 Washer	4	
24	GB5781-86	螺栓 M8 × 60 Bolt	4	
25	Z5G.7.3.16	胶管总成 Hose	1	
26	SF8	选择阀 Valve	1	
27	Z5G.7.3-3	三通接头 Joint	3	
28	Z5G.7.3.8	胶管总成 Hose	1	
29	Z5G.7.3-2	接头 Joint	1	
30	Z5G.7.1-1	螺塞 Plug	1	
31	DJS2-UX/UU	先导阀 Polit Valve	1	

### 30.先导液压系统 Polit Hydraulic System

序号 Sr. No.	零件代号 Part No.	名 称 Part Description	数量 Q'ty	备 注 Remark
32	85Z II.7.3-3	动臂先导阀手柄 Lift Pilot Propulsion Rod	1	
33	Z5G.7.3-1	手柄球 Knob Ball	2	
34	GB808-88	螺母 M12 × 1.25 Nut	4	
35	Z5G(CS).7.3-4	翻斗先导阀手柄 Tilt Polit Propulsions Rod	1	
36	GB5781-86	螺栓 M10 × 25 Bolt	12	
37	85Z III.6.2-11	接头 Joint	1	
38	Z5G.7.3.15	胶管总成 Hose	1	
39	JB982-77	垫圈 18 Washer	1	
40	Z5G.7.3.7A	胶管总成 Hose	1	
41	Z5G.7.3.18	胶管总成 Hose	1	
42	Z5G.7.3.19	胶管总成 Hose	1	
43	Z5G.7.3.12	胶管总成 Hose	2	
44	Z5G.7.3.14A	胶管总成 Hose	1	
45	Z5G.7.3-7	橡胶板 Rubber Plate	4	
46	Z5G.7.3-8	支座板 Plate	2	
47	Z5G.7.3-10	限位杆支座 Support	2	
48	GB6172-86	螺母 M12 Nut	2	
49	Z5G.7.3-9	限位杆 Limit Rod	2	
50	XF-B6	限位阀 limit Valve	2	
51	Z5G.7.3.22	四通接头 Joint	1	
52	Z5G.7.3.20	胶管总成 Hose	1	
53	Z5G.7.3.13	胶管总成 Hose	1	
54	Z5G.7.3.11	胶管总成 Hose	1	
55	Z5G.7.3-6	压板 Split Flange	2	



### 31. 液压油箱 Hydraulic Tank

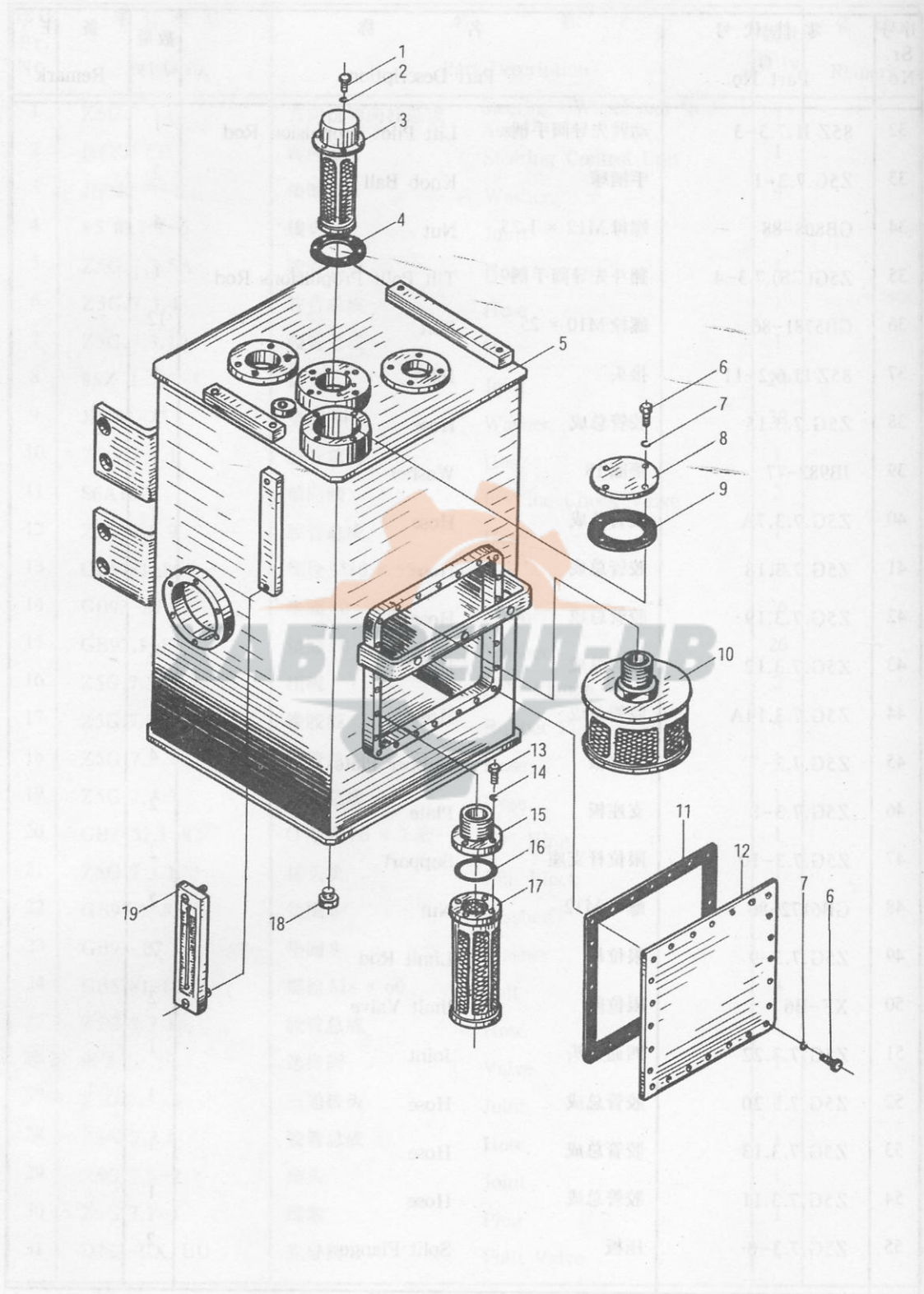

### 31. 液压油箱 Hydraulic Tank

序号 Sr. No.	零件代号 Part No.	名 称 Part Description	数量 Q'ty	备 注 Remark
1		螺栓 M4 × 10      Bolt	6	
2		垫圈 4              Washer	6	
3	PAF2-0.07-0.75 -40F	预压式空气滤清器      Air Filter Assy	1	
4		垫                      Packing	1	
5	Z5G.7.1.27.1	油箱体                  Tank	1	
6	GB5783-86	螺栓 M8 × 25          Bolt	34	
7	GB93-87	垫圈 8                  Washer	34	
8	ZL50E.7.3-6	盖板                      Cover	1	
9	ZL50E.7.3-7	垫片                      Washer	1	
10	ZL50E.7.3.4	回油滤清器              Filter Assy	1	
11	ZL50E.7.3-3A	密封垫                  Packing	1	
12	ZL50E.7.3-2A	盖板                      Cover	1	
13	GB65-85	螺钉 M6 × 25          Screw	4	
14	GB93-87	垫圈 6                  Washer	4	
15	GB6170-86	螺母 M6                  Nut	1	
16	GB3452.1-82	O 型密封圈 82.5 × 3.55      "O" Ring	1	
17	WU630 × 100F-J	吸油滤清器              Filter Assy	1	
18	GB5781-86	螺栓 M16 × 15          Bolt	1	
19	YWZ-250	液位计                  Gauge Assy,Level	1	



## 32. 全液压转向器 Hydraulic Steering Control Units

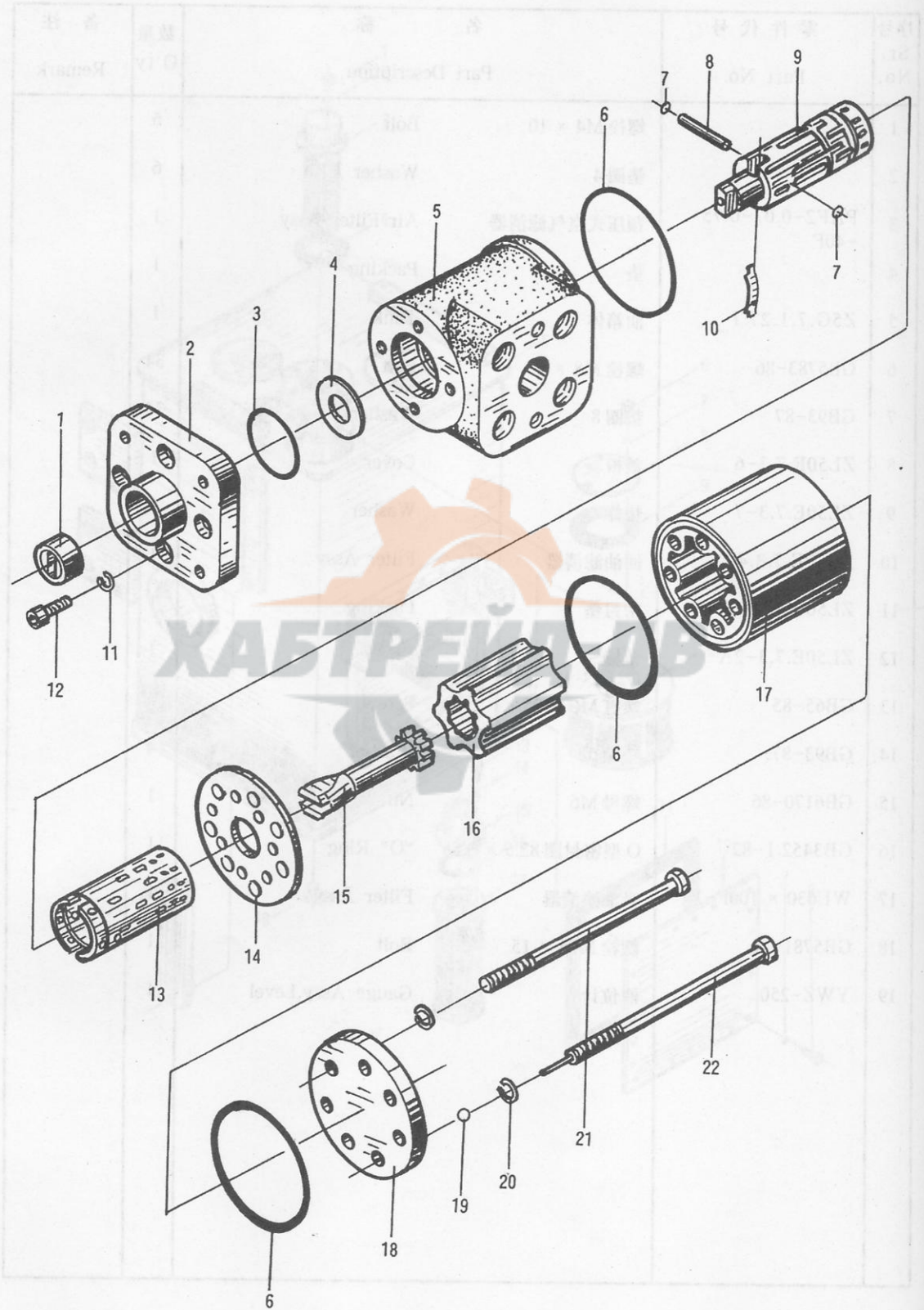

## 32.全液压转向器 Hydraulic Steering Control Units

序号 Sr. No.	零件代号 Part No.	名 称 Part Description	数量 Q'ty	备 注 Remark
1		接头块 Join Block	1	
2		前盖 Front Cap	1	
3		O型密封圈 "O" Ring	1	
4		垫片 Washer	1	
5		阀体 Valve Body	1	
6		O型密封圈 "O" Ring	3	
7		挡片 Snap	2	
8		销 Pin	1	
9		阀芯 Spool	1	
10		弹簧片 Spring Plate	6	
11	GB93-87	垫圈6 Lock Washer	4	
12	GB70-85	螺钉 Screw	4	
13		阀套 Valve Sleeve	1	
14		隔盘 Spacer	1	
15		联动轴 Universal Driving Shaft	1	
16		转子 Rotator	1	
17		定子 Stator	1	
18		后盖 Rear Cap	1	
19		钢球 Ball	1	
20	GB93-87	垫圈10 Lock Washer	7	
21	GB5782-86	螺栓 M10 Bolt	6	
22		螺栓 M10 Bolt	1	



### 33.转斗油缸 Tilt Cylinder

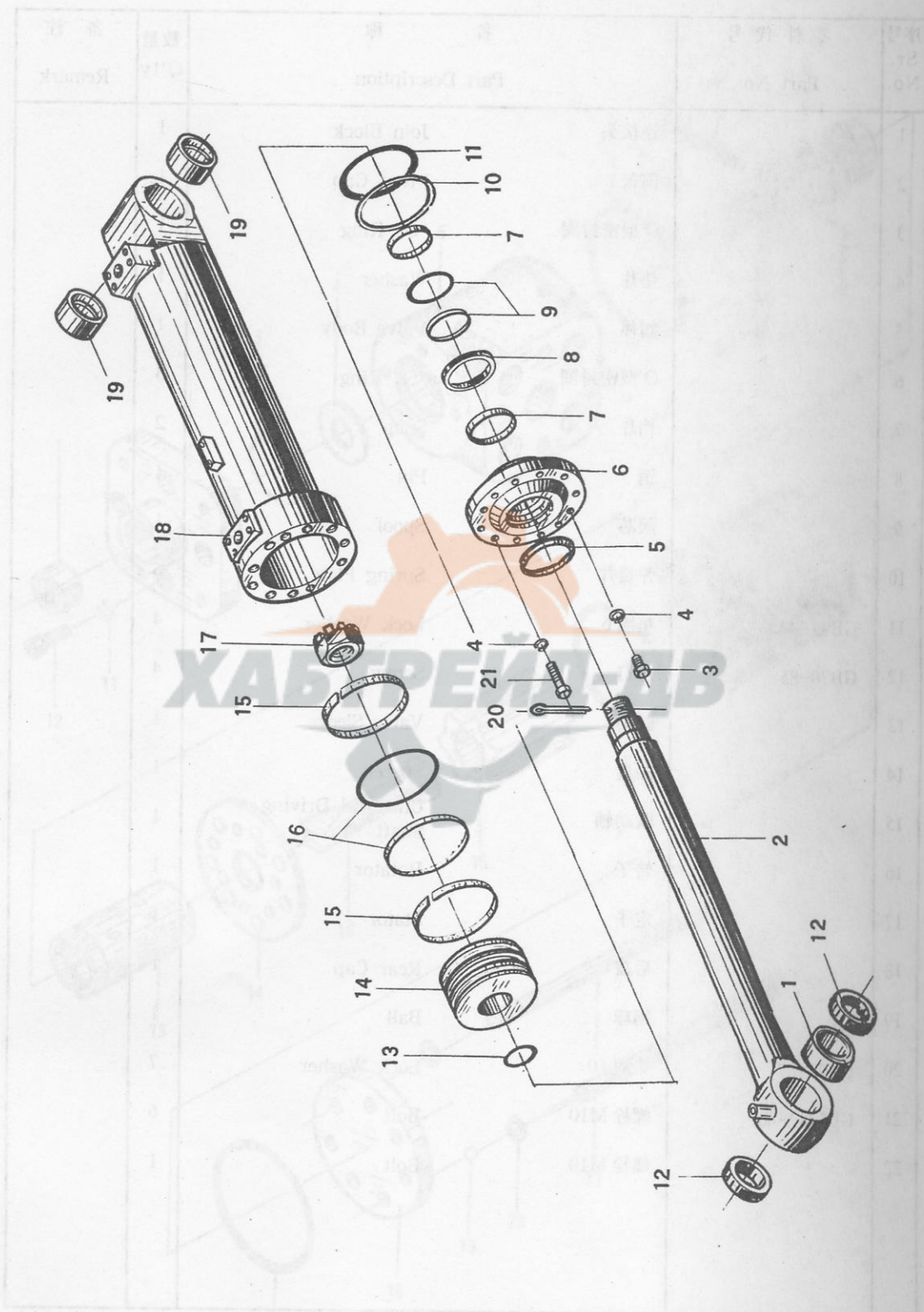

### 33. 转斗油缸 Tilt Cylinder

序号 Sr. No.	零件代号 Part No.	名 称 Part Description	数量 Q'ty	备注 Remark
1	GB304.5-81	关节轴承 GE80ES Spherical	1	
2	Z5G.7.1.1.2	活塞杆 Piston Rod	1	
3	GB5785-86	螺栓 M20 × 2 × 30 Bolt	2	
4	GB93-87	垫圈 20 Lock Washer	12	
5	CK-100	防尘圈 d100 Seal Kit	1	
6	ZL50E.7.1.1-6	缸盖 Cover	1	
7	ZL50E.7.1.1-1	支承环 Supporting Ring	2	
8	JB/JQ22101-87	KYC 密封圈 100 × 120 × 15 "KYC" Ring	1	
9	S-55013	斯特封 d100 Stepseal Ring	1	
10	GB1235-76	挡圈 A180 × 2 Snap Ring Cover	1	
11	GB1235-76	O 型密封圈 180 × 5.7 "O" Ring	1	
12	Z5G.7.1.1-2	防尘挡圈 Snap Ring Cover	2	
13	GB3452.1-82	O 型密封圈 69 × 5.3 "O" Ring	1	
14	ZL50E.7.1.1-2	活塞 Piston	1	
15	ZL50E.7.1.1-3	支承环 Supporting Ring	2	
16	S-55044	格来圈 D180 Glyd Ring	1	
17	ZL50E.7.1.1-4	开槽螺母 Nut	1	
18	Z5G.7.1.1.1	缸体 Cylinder Body	1	
19	Z5G.7.1.1-5	衬套 Lining Bushing	2	
20	GB91-86	开口销 10 × 100 Cotter Pin	1	
21	GB5785-86	螺栓 M20 × 2 × 80 Bolt	10	



### 34. 左右动臂油缸 Left Right Lift Cylinder

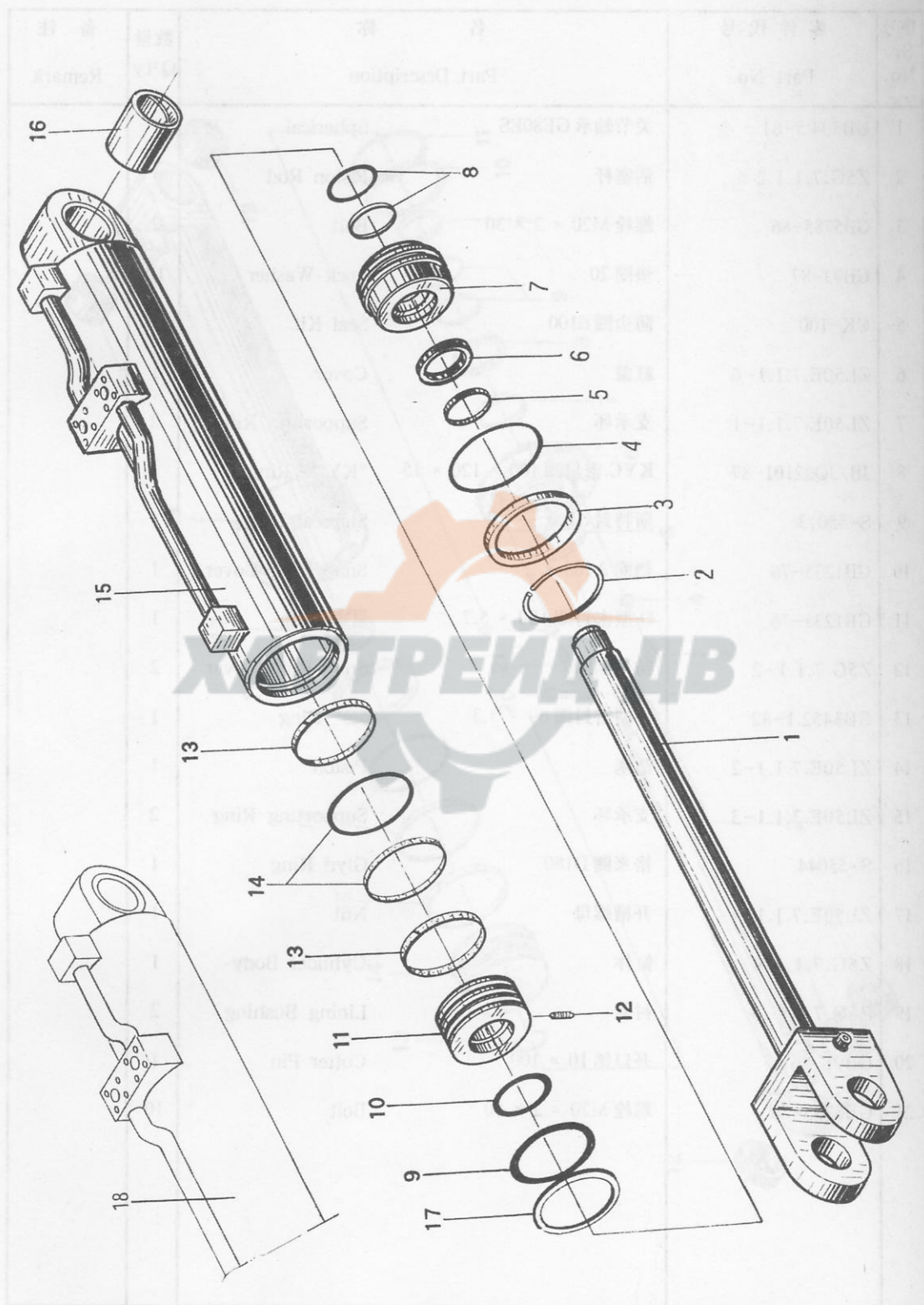

### 34.左右动臂油缸 Left Right Lift Cylinder

序号 Sr. No.	零件代号 Part No.	名 称 Part Description		数量 Q'ty	备注 Remark
1	ZL50E.7.1.3.1	活塞杆	Piston Rod	1	
2	GB894.1-86	挡圈 140	Snap Ring Cover	1	
3	ZL50E.7.1.3-1	挡环	Snap Ring	1	
4	ZL50E.7.1.3-2	挡圈 165	Snap Ring Cover	1	
5	GB10708.3-89	FC 防尘圈 80	Seal Ring	1	
6	JB/JQ22101-87	KYC80 × 95 × 11.5	"KYC" Ring	1	
7	ZL50E.7.1.3-3	导向套	Guide Sleeve	1	
8	S-55013	斯特封 d80	Stepseal Ring	1	
9	GB1235-76	O 型圈 160 × 5.7	"O" Ring	1	
10	GB1235-76	O 型圈 85 × 3.1	"O" Ring	1	
11	ZL50.10.2.6	活塞	Piston	1	
12	GB79-85	螺钉 M12 × 45	Screw	1	
13	ZL50.10.2-7	支承环	Supporting Ring	2	
14	S-55044	格莱圈 d160	Glyd Ring	1	
15	Z5G.7.1.3.1A	缸体(右)	Cylinder Body (Right)	1	
16	ZL50E.7.1.3-7	衬套	Lining Bushing	1	
17	GB1235-76	挡圈 A160 × 2	Snap Ring Cover	1	
18	Z5G.7.1.24.1A	缸体(左)	Cylinder Body (Left)	1	



### 35. 左右转向油缸 Left Right Steering Cylinder

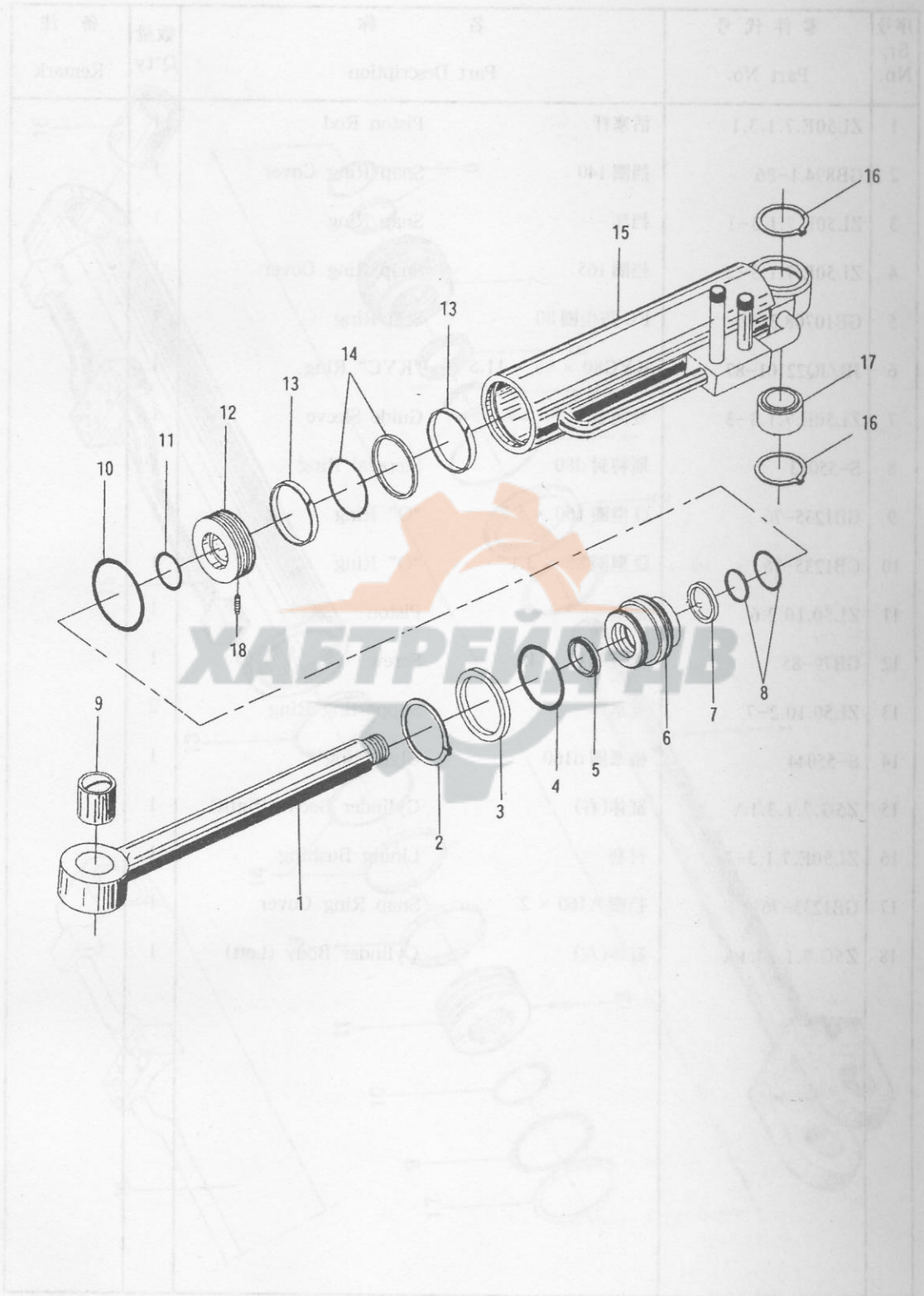

### 35.左右转向油缸 Left Right Steering Cylinder

序号 Sr. No.	零件代号 Part No.	名 称 Part Description	数量 Q'ty	备 注 Remark
1		活塞杆                      Piston Rod	1	
2	GB894.1-86	轴用弹性挡圈 70              Snap Ring Cover	1	
3		挡环                              Snap Ring	1	
4		钢丝挡圈                      Snap Ring Cover	1	
5	GB10708.3-89	Fc 防尘圈 d45                  Seal Ring	1	
6		导向套                          Guide Sleeve	1	
7	JB/JQ22101-87	Kyc 密封圈 45 × 60 × 11.5              "Kyc" Ring	1	
8	S-55013	斯特封 d45                      Stepseal Ring	1	
9		衬套                              Lining Bushing	1	
10	GB1235-76	O 形密封圈 90 × 5.7          "O" Ring	1	
11	GB1235-76	O 形密封圈 50 × 3.1          "O" Ring	1	
12		活塞                              Piston	1	
13		孔用支承环                      Supporting Ring	2	
14	S-55044	格来圈 D90                      Glyd Ring	1	
15		左 缸体                          Left 右 缸体                          Right Tube,Cylinder	1	
16	GB893.1-86	挡圈 62                          Snap Ring Cover	2	
17	GB304.5-81	关节轴承 GE40ES              Cylinder Body (Left)	1	
18	GB79-85	螺钉 M6 × 25                      Screw	1	



### 36. 双联齿轮泵 Twin-Gear Pump

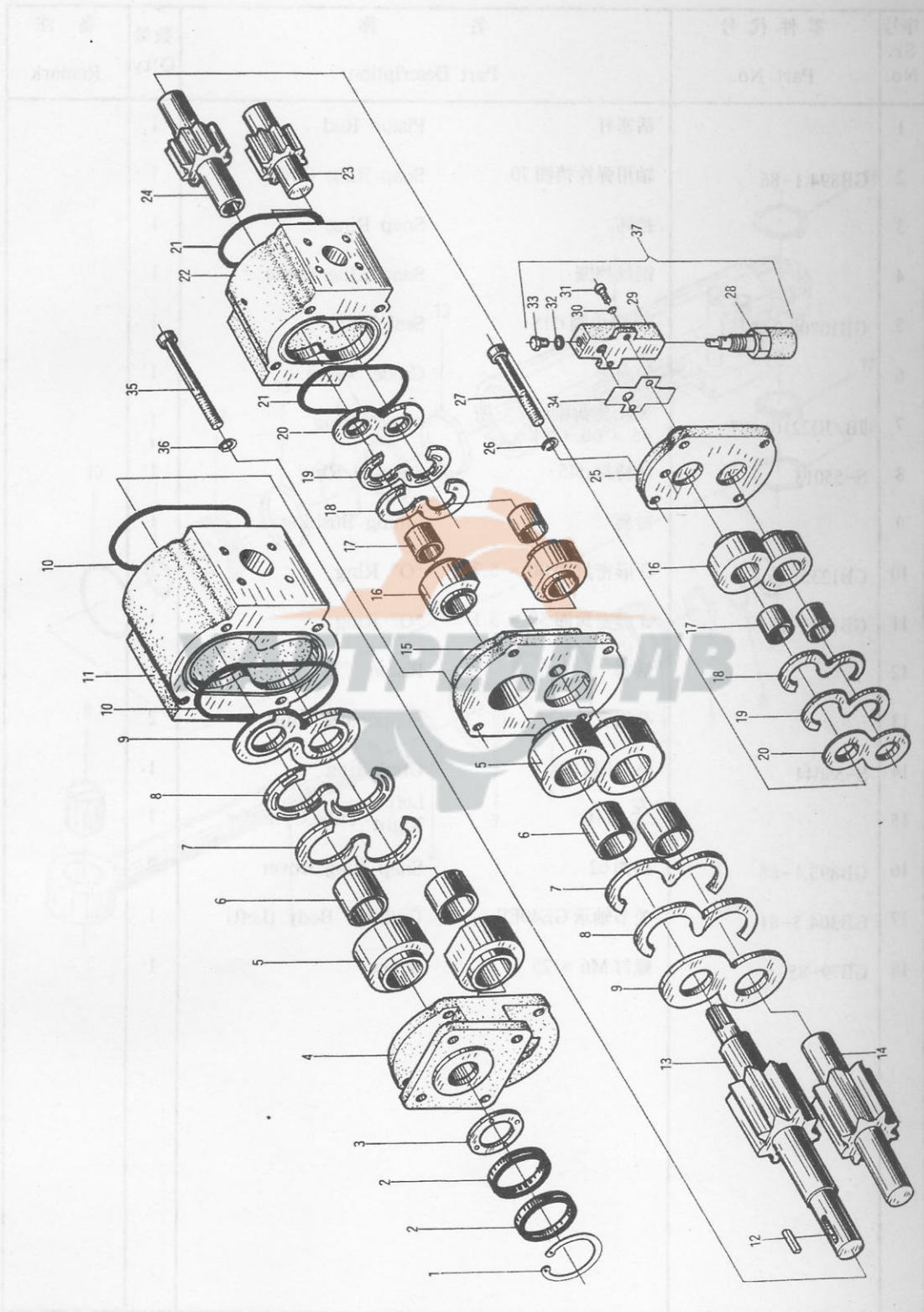

### 36.双联齿轮泵 Twin-Gear Pump

序号 Sr. No.	零件代号 Part No.	名 称 Part Description	数量 Q'ty	备 注 Remark
1	GB893.1-86	挡圈 56 Pinion Needle Roller	1	
2	HG4-692-67	骨架油封 Shaft Seal	2	
3		垫片 PinionSeal Washer		
4		前盖 Front Cover		
5		轴套 Bearing Bush		
6		滑动轴承 Bearing Block	4	
7		挡片 Thrust Washer	4	
8		密封垫 Gasket		
9		侧板 Wear Plate		
10	GB1235-76	O形密封圈 "O" Ring	2	
11		泵体 Housing	1	
12		键 Key	1	
13		主动齿轮轴 Drive Gear Assembly	1	
14		从动齿轮轴 Driven Gear Assembly	1	
15		中间体 Intermediate Housing	1	
16		轴套 Bearing Bush	4	
17		滑动轴承 Bearing Block	4	
18		挡片 Thrust Washer	4	
19		密封垫 Gasket		
20		侧板 Wear Plate		
21	GB1235-76	O形圈 "O" Ring	2	
22		泵体 Housing	1	
23		从动齿轮轴 Driven Gear Assembly	1	
24		主动齿轮轴 Drive Gear Assembly	1	



### 36.双联齿轮泵 Twin-Gear Pump

序号 Sr. No.	零件代号 Part No.	名 称 Part Description	数量 Q'ty	备注 Remark
25		后盖 Back Cover	1	
26	GB93-76	垫圈 Washer	4	
27	GB70-85	螺钉 Screw	4	
28		阀 Valve	1	
29		阀 Valve	1	
30	GB93-76	垫圈 Washer	2	
31	GB70-85	螺钉 Screw	2	
32		O形圈 "O" Ring	1	
33		螺塞 Plug	1	
34	GB93-76	密封垫 Seal Pad	4	
35	GB70-85	螺钉 M16 Screw	4	
36		垫圈 16 Washer	4	
37		溢流阀组件 Release Valve	1	

# 37. 齿轮泵 Gear Pump

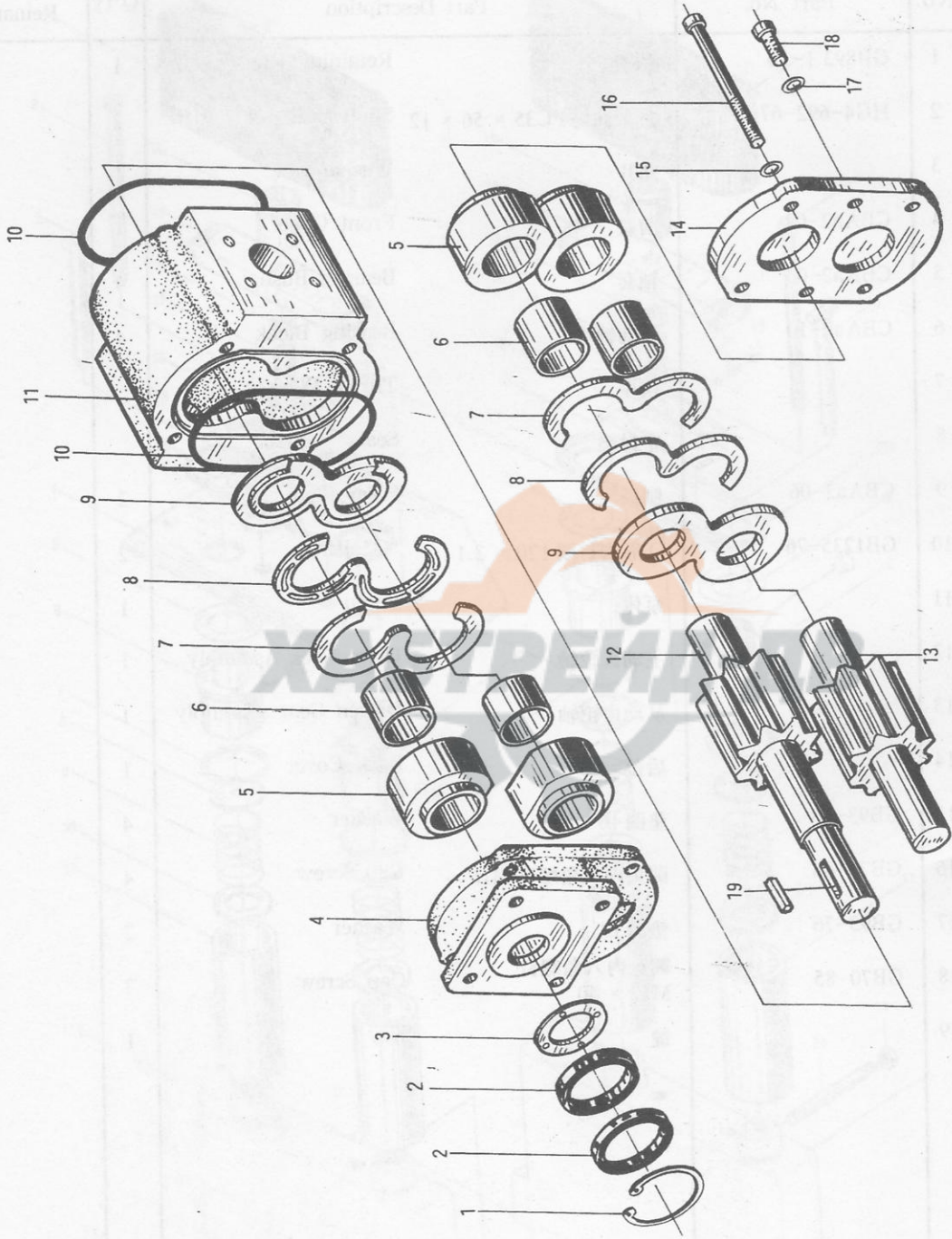



### 37. 齿轮泵 Gear Pump

序号 Sr. No.	零件代号 Part No.	名 称 Part Description	数量 Q'ty	备注 Remark
1	GB893.1-86	档圈 56 Retaining Ring	1	
2	HG4-692-67	骨架油封 PC35 × 56 × 12 Shaft Seal	2	
3		垫片 Washer	1	
4	CBAa2-02	前盖 Front Cover	1	
5	CBAa2-03	轴套 Bearing Bush	4	
6	CBAa2-10	滑动轴承 Bearing Block	4	
7		挡片 Thrust Washer		
8		密封垫 Seal		
9	CBAa2-06	侧板 Wear Plate	2	
10	GB1235-76	O形密封圈 120 × 3.1 "O" Ring	2	
11		泵体 Pump	1	
12		主动齿轮轴 Drive Gear Assembly	1	
13		从动齿轮轴 Driven Gear Assembly	1	
14		后盖 Back Cover	1	
15	GB93-76	垫圈 16 Washer	4	
16	GB70-85	圆头内六角螺钉 M16 Cap Screw	4	
17	GB93-76	垫圈 12 Washer	2	
18	GB70-85	圆头内六角螺钉 M12 × 40 Cap Screw	2	
19		键 Key	1	

### 38. 先导阀 Polit valve

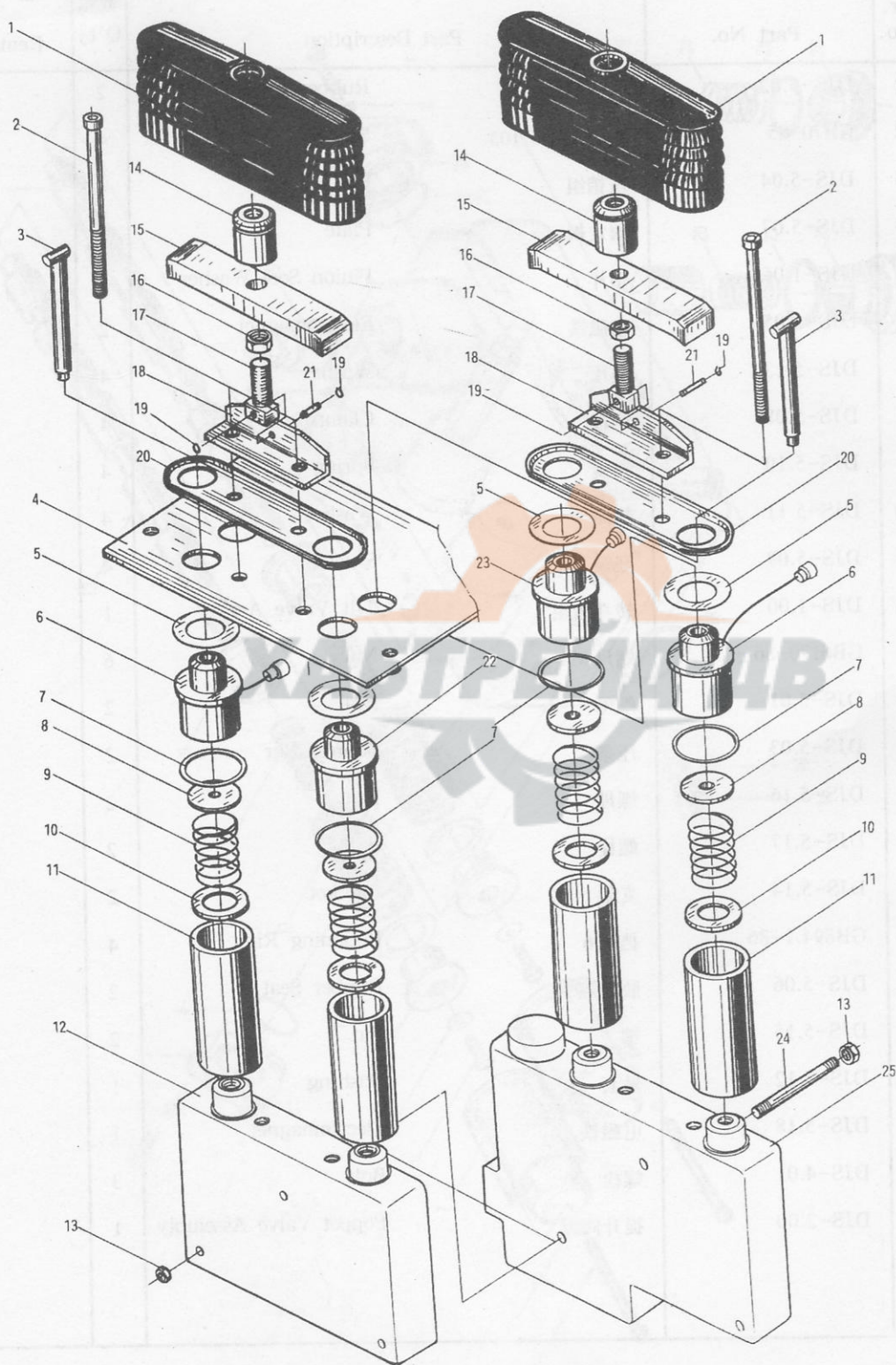



## 38.先导阀 Polit Valve

序号 Sr. No.	零件代号 Part No.	名 称 Part Description	数量 Q'ty	备注 Remark
1	DJS-5.02	橡胶罩 Rubber Cover	2	
2	GB70-85	螺钉 M8 × 105 Screw	4	
3	DJS-5.04	压销组 Pin Assy.	4	
4	DJS-5.07	固定板 Plate	1	
5	DJS-1.05	垫片 Pinion Seal Washer	4	
6	DJS-5.05	电磁铁 Electromagnet	2	
7	DJS-5.13	垫片 Washer	4	
8	DJS-5.08	压板 Clamp	4	
9	DJS-5.10	弹簧 Spring	4	
10	DJS-5.11	垫圈 Washer	4	
11	DJS-5.09	套筒 Sleeve	4	
12	DJS-1.00	转斗阀组 Tilt Valve Assy.	1	
13	GB6170-86	螺母 M8 Nut	6	
14	DJS-5.01	螺母 Nut	2	
15	DJS-5.03	压条 Supress Bar	2	
16	DJS-5.16	螺母 Nut	2	
17	DJS-5.17	螺栓 Bolt	2	
18	DJS-5.14	支架 Bracket	2	
19	GB894.1-86	挡圈 6 Retaining Ring	4	
20	DJS-5.06	胶套座 Rubber Seat	2	
21	DJS-5.15	销 Pin	2	
22	DJS-5.12	轴套 Bushing	1	
23	DJS-5.18	电磁铁 Electromagnet	1	
24	DJS-4.01	螺栓 Bolt	3	
25	DJS-2.00	提升阀组 Poppet Valve Assembly	1	





### 39.多路阀 Multi-Way Valve

序号 Sr. No.	零件代号 Part No.	名 称 Part Description		数量 Q'ty	备注 Remark
1	GB30-76	螺栓 M12 × 20	Bolt	4	
2	GB93-87	垫圈 12	Washer	2	
3	D32-11	盖板	Cover	1	
4	GB1235-76	O 形密封圈 45 × 3.1	"O" Ring	1	
5	GB70-85	圆柱头内六角螺钉 M10 × 100	Cap Screw	4	
6	GB93-76	垫圈 10	Washer	8	
7	D32-5	端盖	Front Cover	2	
8	GB97.1-85	垫圈 12	Washer	2	
9	D32-6	弹簧座	Spring Retainer	4	
10	D32-9	调整垫片	Liner	2组	
11	D32-8	弹簧	Spring	2	
12	D32-7	弹簧	Spring	2	
13	D32-12	转斗阀杆	Tilt Control Rod	1	
14	D32-2	动臂阀杆	Lift Control Rod	1	
15	D32-3	螺塞	Plug	1	
16	GB1235-76	O 形密封圈 20 × 2.4	"O" Ring	1	
17	GB1235-76	O 形密封圈 60 × 3.1	"O" Ring	2	
18	D32-4	阀体	Housing	1	
19	D32-15	补油阀	Prefill Valve	1	
20	D32-14	弹簧	Spring	1	
21	GB1235-76	O 形密封圈 50 × 3.1	"O" Ring	3	
22	D32-13	补油阀盖	Prefill Valve Cover	1	
23	D32-17	单向阀	Check Valve	3	
24	D32-16	弹簧	Spring	3	
25	GB1235-76	O 形密封圈 44 × 3.5	"O" Ring	3	
26	D32-19	阀盖	Valve Cover	3	
27	GB70-85	圆柱头内六角螺钉 M10 × 45	Screw	4	
28	D32-1	端盖	Cover	2	
29	D32.2a	安全阀	Relief Valve	1	
30	D32.1	过油阀 (4T4832)	Relief Valve	1	
	D32.1	过油阀 (4T4833)	Relief Valve	1	

# 40. 流量放大阀 Flow-Amplifying Valve

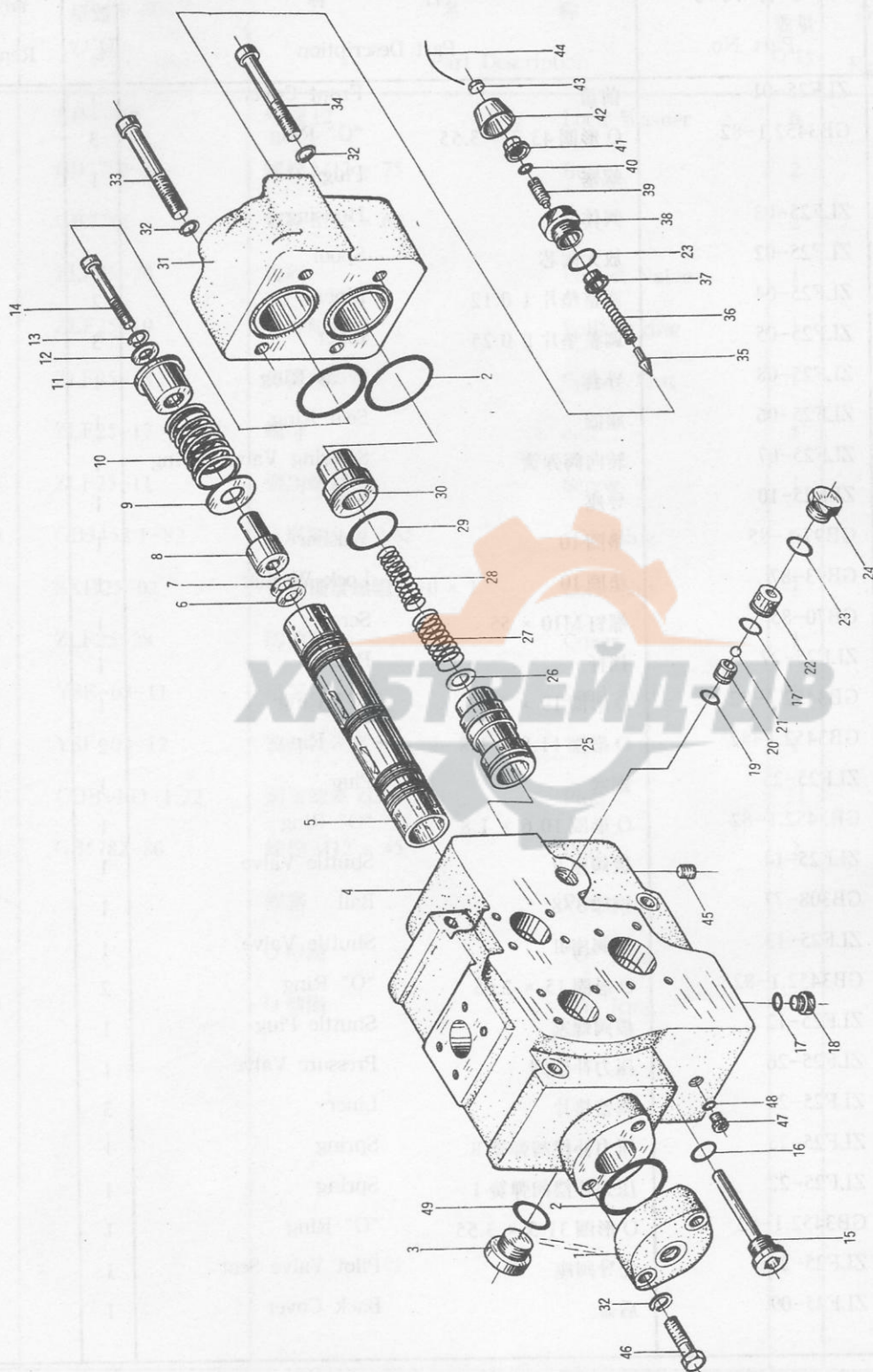



## 40.流量放大阀 Flow-Amplifying Valve

序号 Sr. No.	零件代号 Part No.	名 称 Part Description	数量 Q'ty	备注 Remark
1	ZLF25-01	前盖 Front Cover	1	
2	GB3452.1-82	O形圈 43.7 × 3.55 "O" Ring	3	
3		螺塞 Plug	1	
4	ZLF25-03	阀体 Housing	1	
5	ZLF25-02	放大阀芯 Spool	1	
6	ZLF25-04	调整垫片 I 0.12 Liner	2	
7	ZLF25-05	调整垫片 II 0.25 Liner	3	
8	ZLF25-08	导套 Wear Ring	1	
9	ZLF25-06	座圈 Seat Ring	1	
10	ZLF25-07	转向阀弹簧 Steering Valve Spring	1	
11	ZLF25-10	导座 Seat	1	
12	GB97.1-85	垫圈 10 Washer	1	
13	GB93-87	垫圈 10 Lock Washer	1	
14	GB70-85	螺钉 M10 × 55 Screw	1	
15	ZLF25-27	挡杆 Rod	1	
16	GB3452.1-82	O形圈 19 × 2.65 "O" Ring	1	
17	GB3452.1-82	O形圈 11.8 × 1.8 "O" Ring	2	
18	ZLF25-25	螺塞 Plug	1	
19	GB3452.1-82	O形圈 10.6 × 1.8 "O" Ring	1	
20	ZLF25-14	梭阀座 II Shuttle Valve	1	
21	GB308-77	钢球 3/8" Ball	1	
22	ZLF25-13	梭阀座 II Shuttle Valve	1	
23	GB3452.1-82	O形圈 15 × 2.65 "O" Ring	2	
24	ZLF25-12	梭阀螺塞 Shuttle Plug	1	
25	ZLF25-26	压力补偿阀 Pressure Valve	1	
26	ZLF25-24	调整垫片 Liner	3	
27	ZLF25-23	压力补偿阀弹簧 II Spring	1	
28	ZLF25-22	压力补偿阀弹簧 I Spring	1	
29	GB3452.1-82	O形圈 31.5 × 3.55 "O" Ring	1	
30	ZLF25-21	先导阀座 Pilot Valve Seat	1	
31	ZLF25-09	后盖 Back Cover	1	

## 40.流量放大阀 Flow-Amplifying Valve

序号 Sr. No.	零件代号 Part No.	名 称 Part Description	数量 Q'ty	备 注 Remark
32	GB93-87	垫圈 12 Lock Washer	6	
33	GB5782-86	螺栓 M12 × 75 Bolt	2	
34	GB5782-8	螺栓 M12 × 65 Bolt	2	
35	ZLF25-20	锥阀 Poppet Valve	1	
36	ZLF25-19	先导阀弹簧 Pilot Spring	1	
37	ZLF25-18	弹簧座 Spring Seat	1	
38	ZLF25-17	螺母 Nut	1	
39	ZLF25-11	调压螺钉 Screw	1	
40	GB3452.1-82	O 形圈 9 × 2.65 "O" Ring	6	
41	SXH25-02	密封锁紧螺帽 M10 × 1 Lock Nut	1	
42	ZLF25-28	防护罩 Cover	1	
43	Y8F-03-11	铅封 Lead Seal	1	
44	Y8F-03-12	镀锌铁丝 0.6 × 50 Wire	1	
45	CDB-FO-1.22	圆锥螺塞 ZG1/8" Plug	11	
46	GB5782-86	螺栓 M12 × 45 Bolt	2	
47		螺塞 Plug		
48		O 型圈 "O" Ring		
49		O 型圈 "O" Ring		



# 41. 限位阀 Limiting Valve

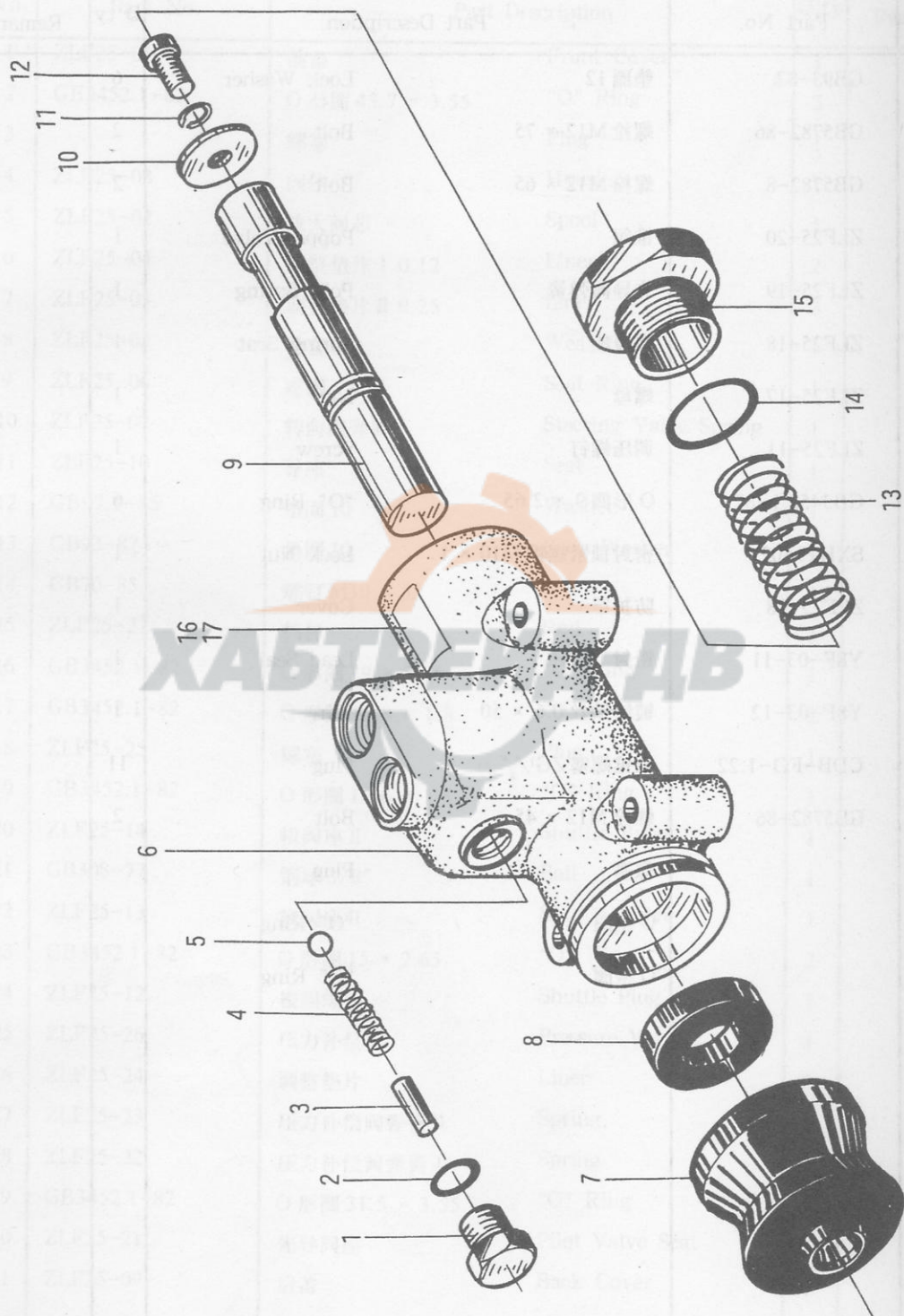

## 41.限位阀 Limiting Valve

序号 Sr. No.	零件代号 Part No.	名称 Part Description	数量 Q'ty	备注 Remark
1	XF-B6-05	螺塞 Plug	1	
2	GB3452.1-82	O形密封圈 10 × 1.8 "O" Ring	1	
3	GB879-86	销 5 × 20 Pin	1	
4	XF-B6-06	弹簧 Spring	1	
5	GB308-77	钢球 $\Phi$ 9.5 Ball	1	
6	XF-B6-04	阀体 Housing	1	
7	XF-B6-02	保护套 Bushing	1	
8	XF-B6-03	唇口密封圈 Seal	1	
9	XF-B6-01	阀杆 Rod	1	
10	XF-B6-07	垫片 Washer	1	
11	GB93-76	垫圈 8 Lock Washer	1	
12	XF-B6-08	内六角螺栓 Bolt	1	
13	XF-B6-10	弹簧 Spring	1	
14	GB3452.1-82	O形密封圈 26.5 × 2.65 "O" Ring	1	
15	XF-B6-09	螺塞 Plug	1	
16	XF-B6-11	标牌 Scutcheon	1	
17	GB827-86	铆钉 2 × 4 Rivet	2	



## 42. 选择阀 Selective Valve

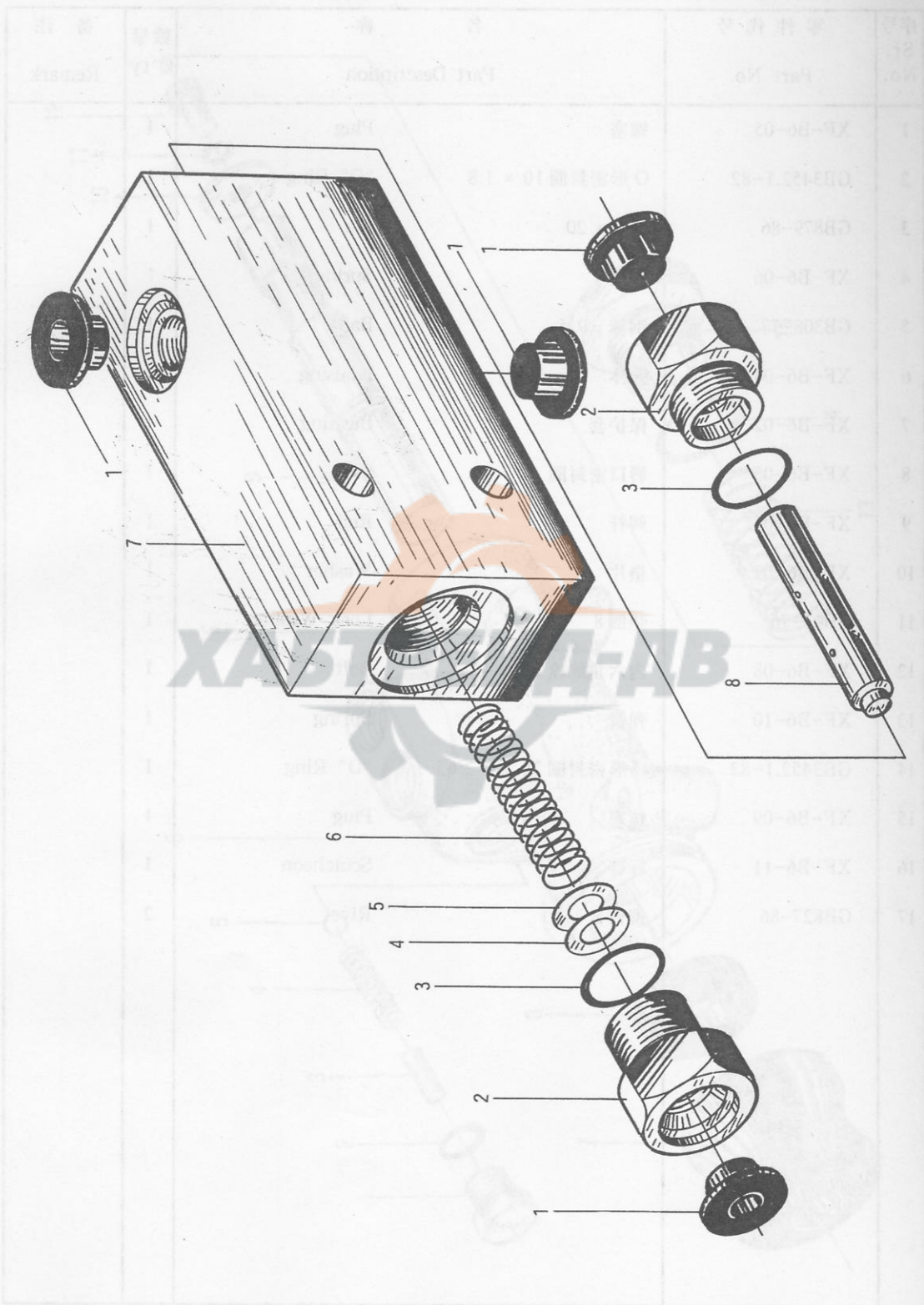

## 42.选择阀 Selective Valve

序号 Sr. No.	零件代号 Part No.	名 称 Part Description	数量 Q'ty	备 注 Remark
1		堵头 Plug	4	
2		接头体 Connector	2	
3		O形密封圈 20 × 1.8 "O" Ring	2	
4		薄调整垫片 Liner	3	
5		调整垫片 Liner	5	
6		弹簧 $F 14.3 \times F 2.8 \times F 50.8$ Spring	1	
7		阀体 Housing	1	
8		阀芯 Spool	1	





# 43.制动系统 Brake System

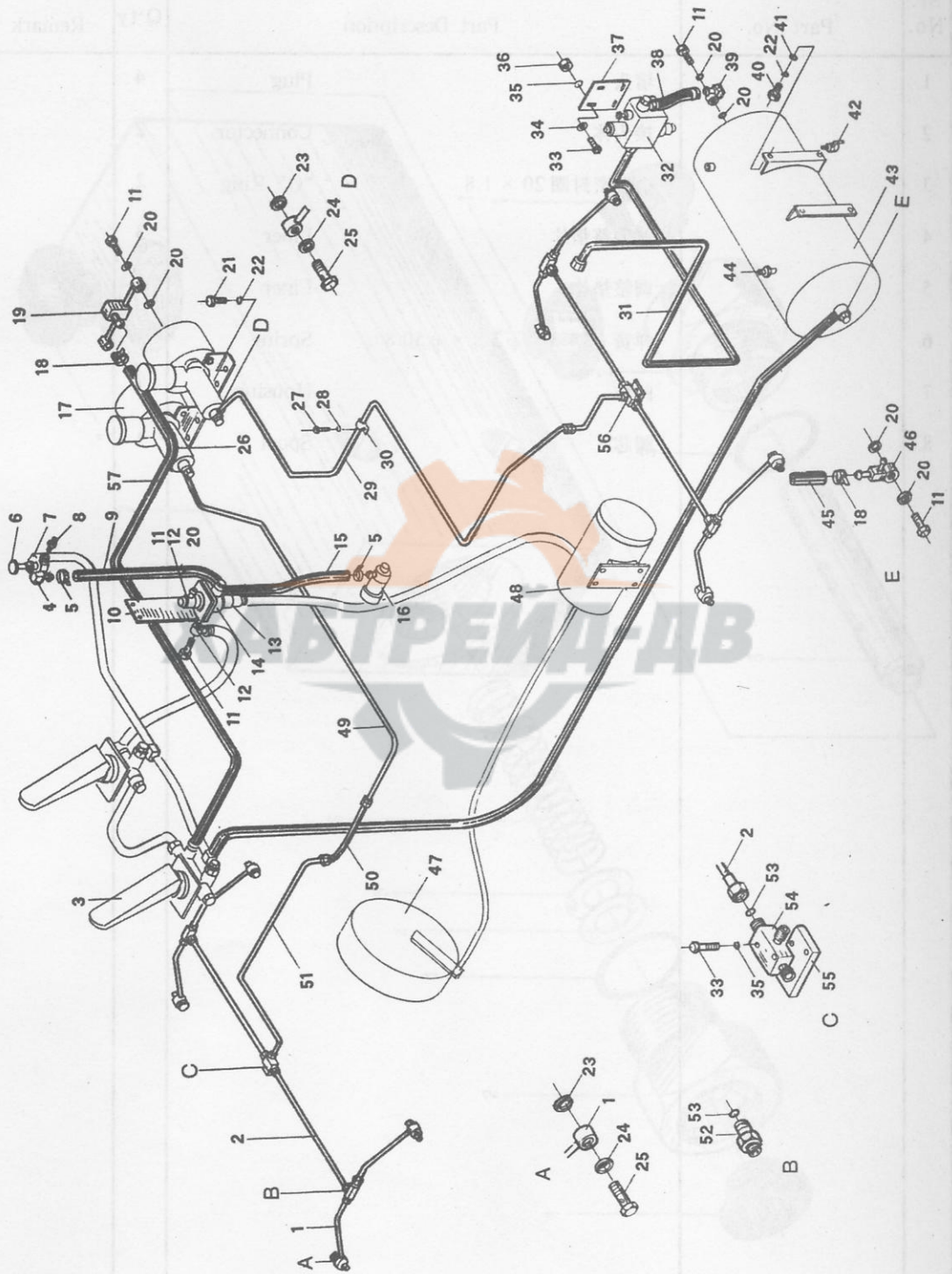

## 43.制动系统 Brake System

序号 Sr. No.	零件代号 Part No.	名 称 Part Description	数量 Q'ty	备 注 Remark
1	ZL50.12.10	制动钳油管 Tube	8	
2	ZL50.12.1 付	前桥油管 Tube	4	
3	Z5G.9.1	制动控制器 Brake Governor	1	
4	ZL50E.9A-6	接头 Joint	1	
5	JB3616.1-84	双钢丝箍 15-18 Clamp	14	
6	QZ50-3526001	手控制动阀 Brake Governor	1	
7	ZL50E.9A-5	接头 Joint	1	
8	ZL50F.9-5	螺堵 Plug	1	
9	Z5G.9.7-1	气管 Air Pipe	1	
10	Z5G.9.6-1	安装板 Plate	1	
11	ZL40.12.5-1	螺栓 Bolt	8	
12	ZL40.12.9-3A	接头 Joint	3	
13	Z5G.9.6-2	三通 Tee Joint	1	
14	QZ50	气控截止阀 Valve	1	
15	Z5G.9.6-2	至切断阀气管 Air Pipe	1	
16	ZL50E.9.6	切断气缸 Brake Air Cylinder	1	
17	XM60	加力泵 Air Master	2	
18	JB3616.1-84	双钢丝箍 18-22 Clamp	6	
19	ZL50E.9.3.1A	三通泵 Tee Tube	1	
20	JB982-77	组合垫圈 22 Washer	15	
21	GB5781-86	螺栓 M10 × 20 Bolt	4	
22	GB93-87	垫圈 10 Washer	10	
23	JB982-77	组合垫圈 14 Washer	10	
24	ZL40.12.4-17	垫圈 Washer	10	
25	ZL40.12.4-14	管接头 Joint	10	
26	Z5G.9.2-1	气管 Air Pipe	1	
27	GB6170-86	螺母 M6 Nut	12	
28	GB93-87	垫圈 6 Washer	12	
29	ZL50E.9.10	后桥油管 Tube	1	
30	85Z.08.1-10	管夹 Clamp	12	
31	Z5G.9.3A	进气管 Air Pipe	1	



## 43.制动系统 Brake System

序号 Sr. No.	零件代号 Part No.	名 称 Part Description	数量 Q'ty	备 注 Remark
32	SH380A-3511010	多功能卸荷阀 Valve Group	1	
33	GB5780-86	螺栓 Bolt	6	
34	GB96-85	垫圈 8 Washer	6	
35	GB93-87	垫圈 8 Washer	6	
36	GB6170-86	螺母 M8 Nut	2	
37	Z5G.9-1	安装板 Plate	1	
38	Z5G.9.4-1	进气管 Air Pipe	1	
39	ZL40.12.9-4	接头 Joint	3	
40	GB5783-86	螺栓 8 Bolt	6	
41	GB97.1-85	垫圈 8 Washer	6	
42	ZL40A.12.4-1	放水阀 Drain Valve	1	
43	Z5G.9.4.1	储气缸 Air Tank	1	
44	HF150	安全阀 Safe Valve	1	
45	Z5G.9.4-2	出气管 Air Pipe	1	
46	Z5G(I).9.4.2	三通接头 Joint	1	
47	ZL40A.13A.1	手制动器总成 Breaker	1	
48	ZL50E.9.7	制动气缸 Break Air Cylinder	1	
49	ZL50E.9.8	前刹车油油管 Tube	1	
50	ZJ303506025A	跃进用制动软管 Hose	2	
51	ZL50E.9.1	前桥长油管 Tube	1	
52	JB990-77	接头体 6 Joint	4	
53	GB1235-76	O 型圈 8 × 1.9 "O" Ring	16	
54	ZL40.12.1	前桥油路三通接头 Tee Joint	1	
55	ZL40.12-1	固定块 Fixture Block	2	
56	ZL40.12-2	后桥油路三通接头 Tee Joint	1	
57		胶管 F 13-2000 Hose		

# 44. 手制动 Hand Brake





## 44.手制动 Hand Brake

序号 Sr. No.	零件代号 Part No.	名 称 Part Description	数量 Q'ty	备 注 Remark
1	GB882-86	销轴 B10 × 35 Shift Pin	2	
2	GB91-86	开口销 3.2 × 16 Cotter Pin	2	
3	ZL40.7.5-2	接头 M10 Joint	1	
4	GB6170-86	螺母 M10 Nut	1	
5	ZL40A.13.4	固定支座 Fixture	1	
6	ZL50E.9.12	操纵软轴 Cable	1	
7	GB6170-86	螺母 M16 Nut	2	
8	ZL40.13.3-3A	滑块 Slide Block	1	
9	ZL40.13.3-4A	U型螺栓 "U" Bolt	2	
10	ZL50E.9.7	制动气缸 Brake Air Cylinder	1	
11	GB6170-86	螺母 M6 Nut	4	
12	GB93-87	垫圈 6 Lock Washer	4	
13	GB5783-86	螺栓 M12 × 25 Bolt	4	
14	GB93-87	垫圈 12 Lock Washer	4	
15	GB97.1-85	垫圈 12 Washer	4	
16	GB982-77	组合垫圈 14 Seal Washer	1	
17	ZL50E.9A-8	接头 Joint	1	
18	ZBJ15001-87	喉箍 d20 Clamp	2	
19	ZL50E.9A-7	胶管 F10 × F19 Air Pipe	1	
20	GB5780-86	螺栓 M10 × 40 Bolt	2	
21	GB93-87	垫圈 10 Lock Washer	2	
22	GB97.1-85	垫圈 10 Washer	2	
23	GB93-87	垫圈 M16 Lock Washer	2	

# 45. 制动控制器 Brake Controller

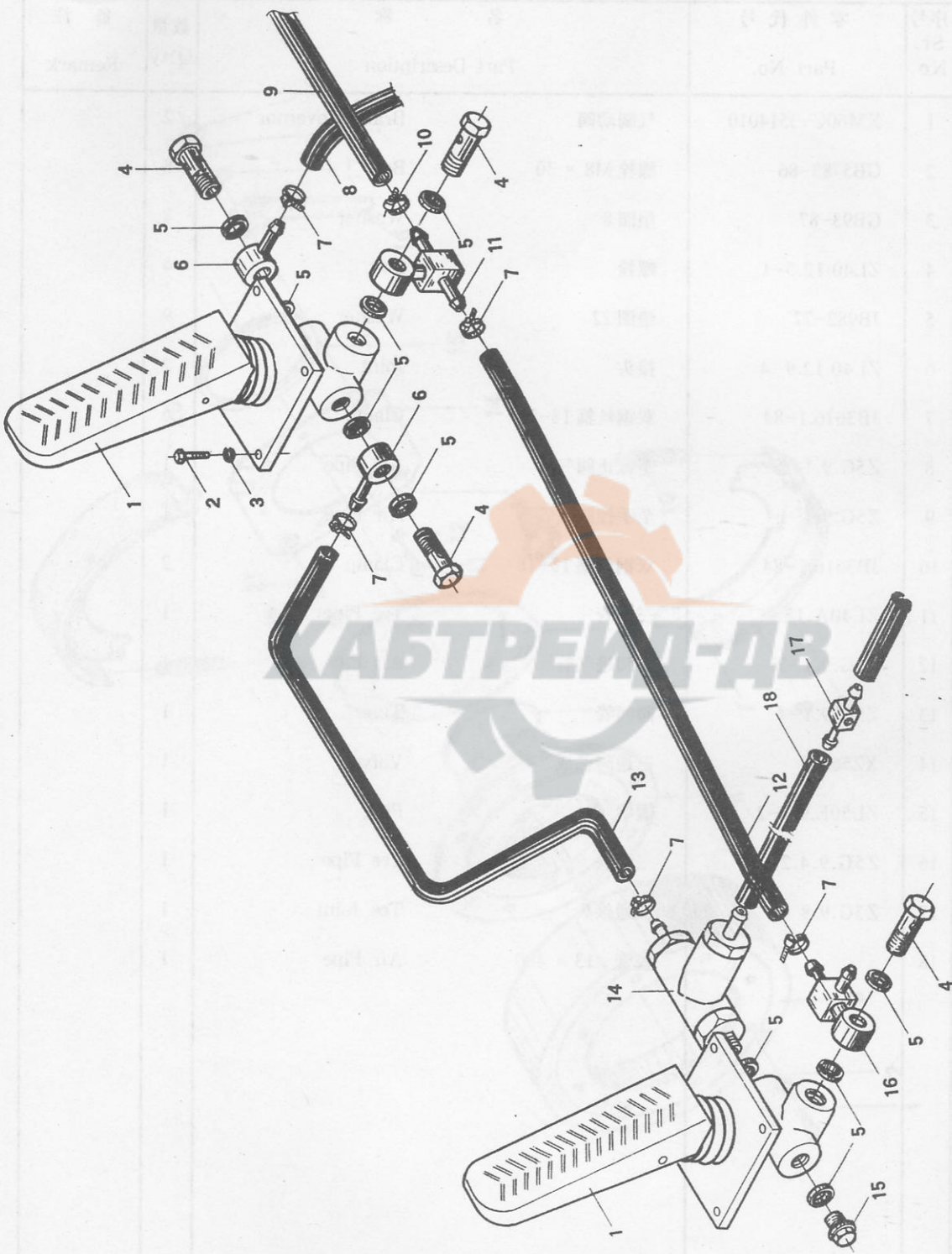



## 45.制动控制器 Brake Controller

序号 Sr. No.	零件代号 Part No.	名 称 Part Description	数量 Q'ty	备 注 Remark
1	XM60C-3514010	气制动阀 Brake Governor	2	
2	GB5783-86	螺栓 M8 × 30 Bolt	8	
3	GB93-87	垫圈 8 Washer	8	
4	ZL40.12.5-1	螺栓 Bolt	4	
5	JB982-77	垫圈 22 Washer	9	
6	ZL40.12.9-4	接头 Joint	2	
7	JB3616.1-84	双钢丝箍 18-22 Clamp	6	
8	Z5G.9.1-2	至截止阀气管 Air Pipe	1	
9	Z5G.9.1-1	至手控阀气管 Air Pipe	1	
10	JB3616.1-84	双钢丝箍 15-18 Clamp	2	
11	ZL40A.12.9.2	三通管 Tee Pipe	1	
12	Z5G.9.1-3	右阀进气管 Air Pipe	1	
13	Z5G.9.1-4	阀间管 Tube	1	
14	XZ560	三通阀总成 Valve	1	
15	ZL50E.9.2-2	螺堵 Plug	1	
16	Z5G.9.4.2	三通管 Tee Pipe	1	
17	Z5G.9.8	三通接头 Tee Joint	1	
18		胶管 $\Phi 13 \times 400$ Air Pipe	1	

# 46. 手制动器总成 Parking Braker Assy

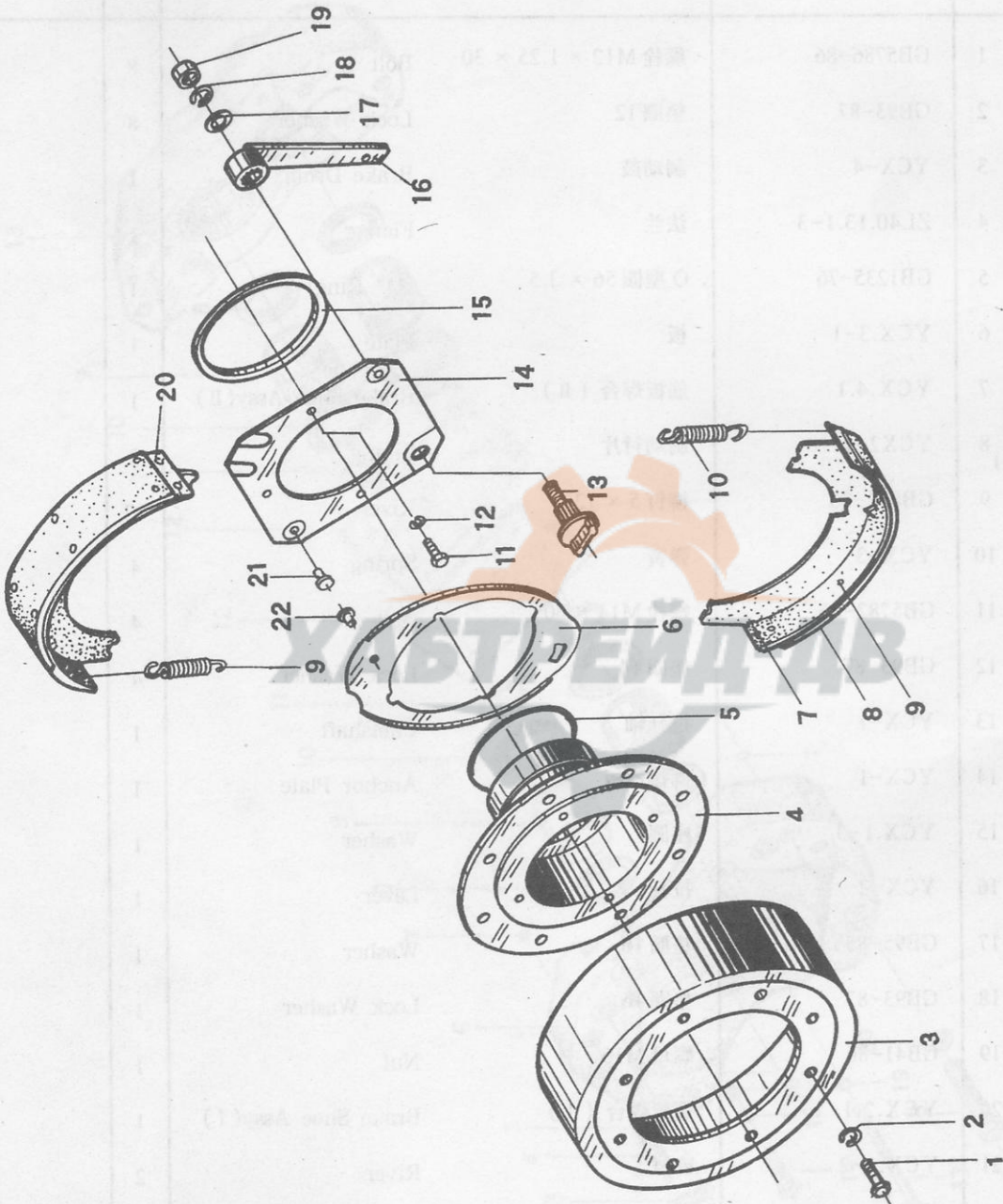



## 46.手制动器总成 Parking Braker Assy

序号 Sr. No.	零件代号 Part No.	名 称 Part Description	数量 Q'ty	备 注 Remark
1	GB5786-86	螺栓 M12 × 1.25 × 30 Bolt	8	
2	GB93-87	垫圈 12 Lock Washer	8	
3	YCX-4	制动鼓 Brake Drum	1	
4	ZL40.13.1-3	法兰 Flange	1	
5	GB1235-76	O 型圈 56 × 3.5 "O" Ring	1	
6	YCX.3-1	板 Plate	1	
7	YCX.4.1	筋板焊合 ( II ) Brake Shoe Assy( II )	1	
8	YCX2-1	制动衬片 Lining	2	
9	GB872-86	铆钉 5 × 12 River	12	
10	YCX-3	弹簧 Spring	4	
11	GB5782-86	螺栓 M14 × 30 Bolt	4	
12	GB93-87	垫圈 14 Lock Washer	4	
13	YCX-1	拉杆轴 Camshaft	1	
14	YCX-1	铆接座板 Anchor Plate	1	
15	YCX.1-3	座圈 Washer	1	
16	YCX-2	拉杆 Lever	1	
17	GB95-85	垫圈 16 Washer	1	
18	GB93-87	垫圈 16 Lock Washer	1	
19	GB41-86	螺母 M16 Nut	1	
20	YCX.2.1	筋板焊合 ( I ) Brake Shoe Assy( I )	1	
21	YCX.1-2	铆钉 River	2	
22	YCX.3-2	铆钉 River	1	

# 47. 盘式制动器 Disk Brake

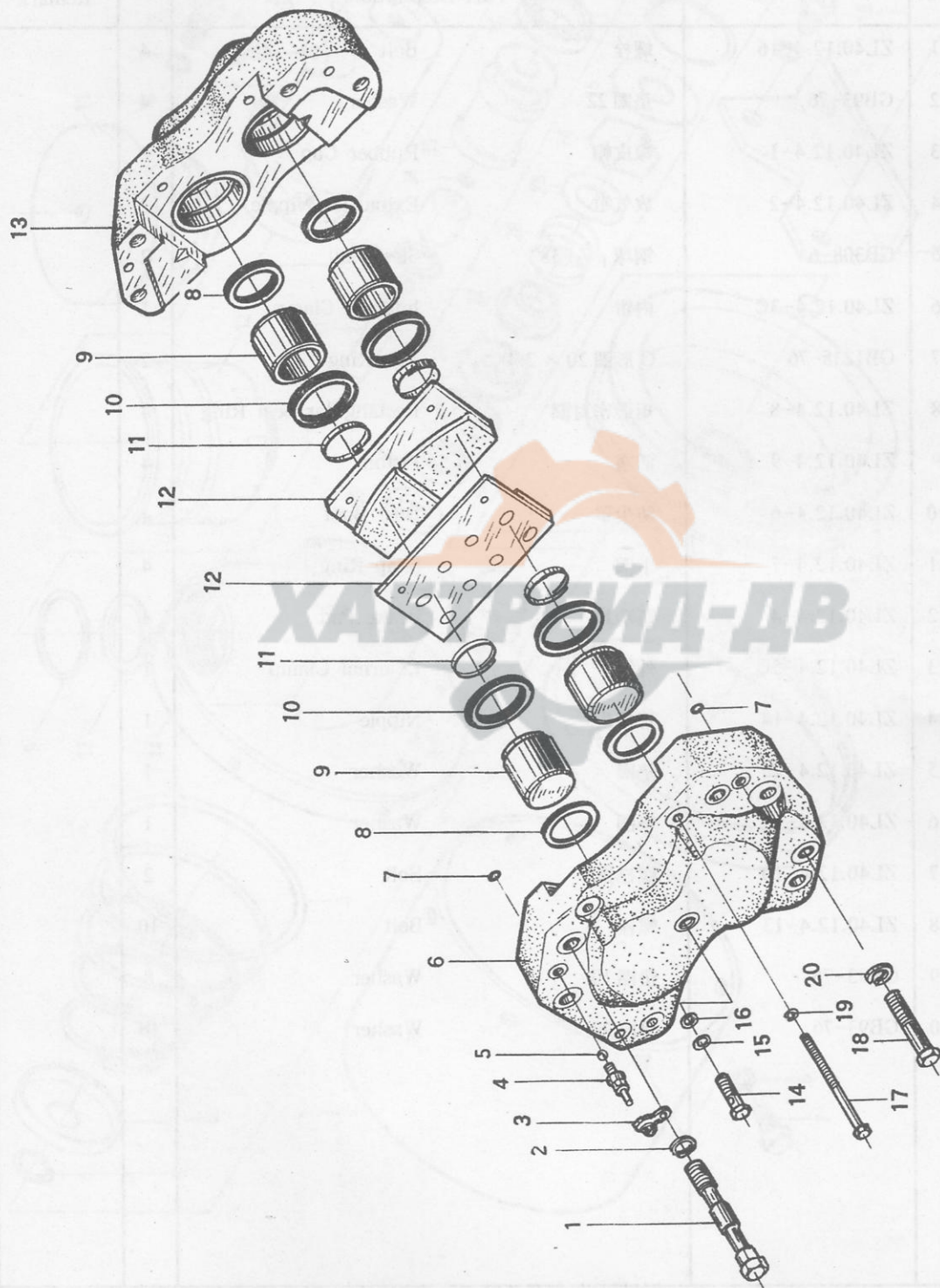



## 47. 盘式制动器 Disk Brake

序号 Sr. No.	零件代号 Part No.	名 称 Part Description	数量 Q'ty	备 注 Remark
1	ZL40.12.4-16	螺栓 Bolt	4	
2	GB93-76	垫圈 22 Washer	4	
3	ZL40.12.4-1	橡皮帽 Rubber Cap	2	
4	ZL40.12.4-2	放气咀 Exhauster Nipple	2	
5	GB308-64	钢球 $\Phi$ 7.938 Steel Ball	2	
6	ZL40.12.4-3C	内钳 Internal Clamp	1	
7	GB1235-76	O 形圈 20 × 2.4 "O" Ring	2	
8	ZL40.12.4-8	矩形密封圈 Rectangular Seal Ring	4	
9	ZL40.12.4-9	活塞 Piston	4	
10	ZL40.12.4-6	防尘罩 Dust Boot	4	
11	ZL40.12.4-7	卡圈 Snap Ring	4	
12	ZL40.12.4-4	制动片 Brake Pad	4	
13	ZL40.12.4-5C	外钳 External Clamp	1	
14	ZL40.12.4-14	管接头 Nipple	1	
15	ZL40.12.4-15	垫圈 Washer	1	
16	ZL40.12.4-17	垫圈 Washer	1	
17	ZL40.12.4-10	螺栓销 Bolt	2	
18	ZL40.12.4-13	螺栓 Bolt	10	
19	GB93-76	垫圈 10 Washer	8	
20	GB93-76	垫圈 20 Washer	16	

# 48. 空气加力泵组 Air Master Unit

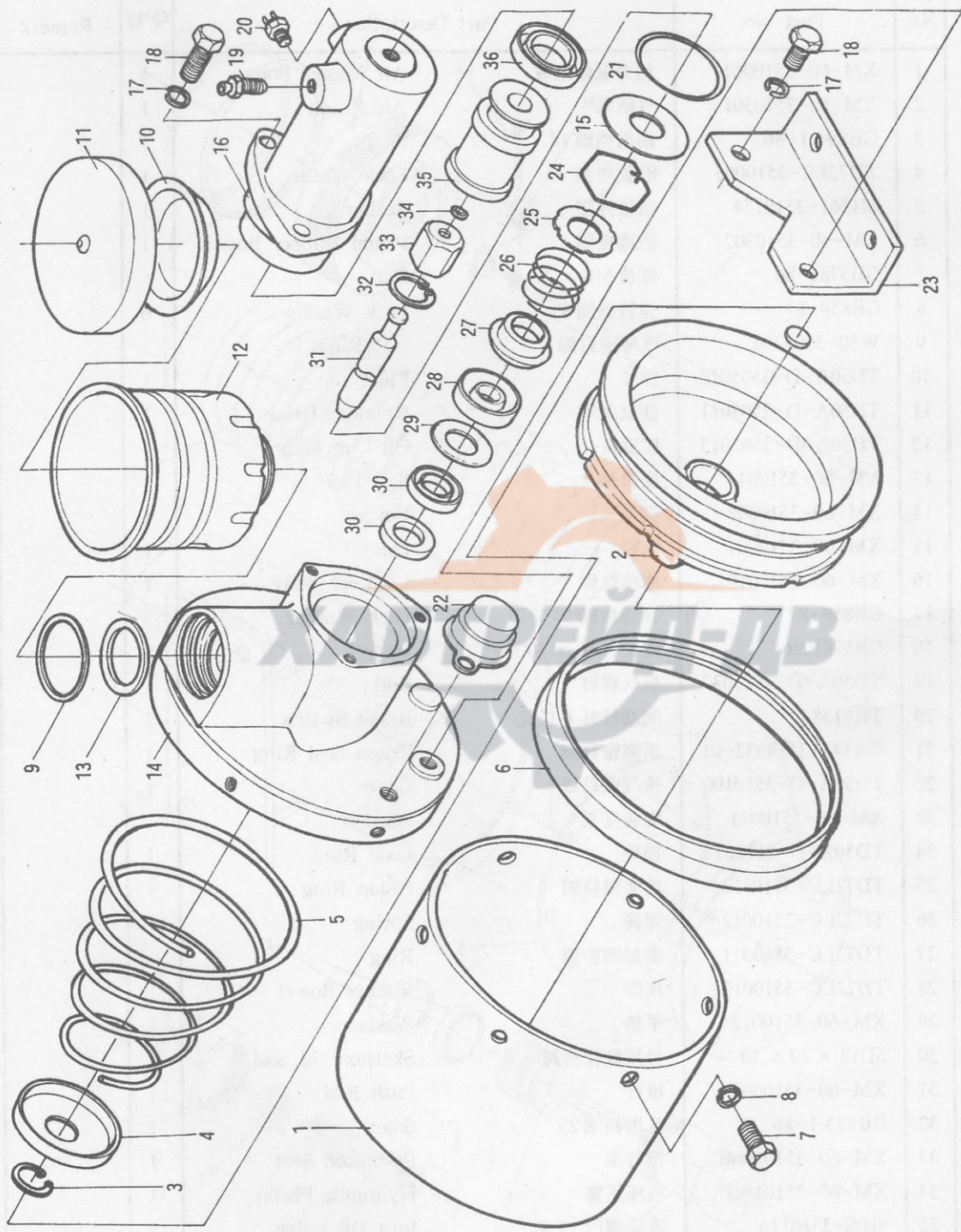



## 48.空气加力泵组 Air Master Unit

序号 Sr. No.	零件代号 Part No.	名 称 Part Description		数量 Q'ty	备 注 Remark
1	XM-60-3510001	加力泵体总成	Air Master Body	1	
2	XM-60-3510301	气活塞	Air Piston	1	
3	GB894.1-86	轴用挡圈 18	Snap	1	
4	TD72LC-3510005	限位垫圈	Lock Washer	1	
5	SH361-3519154	回位弹圈	Spring	1	
6	XM-60-3510302	活塞皮圈	Piston Rubber Bowel	1	
7	GB5781-86	螺栓 M8 × 20	Bolt	6	
8	GB859-87	弹簧垫圈 8	Lock Washer	6	
9	W50-3505006	O 型密封圈	"O" Ring	1	
10	TD50A-D-3505012	浮子	Float	1	
11	TD50A-D-3505011	油缸盖罩	Cylinder Head	1	
12	TD50A-D-3505013	贮油缸	Oil Cup Body	1	
13	XM-60-3510014	密封垫片	Seal Pad	1	
14	XM-60-3510008	端盖	Cover	1	
15	XM-60-3510007	垫板	Plate	1	
16	XM-60-3510010	液压缸体	Cylinder Body	1	
17	GB859-87	弹簧垫圈 10	Lock Washer	5	
18	GB5781086	螺栓 M10 × 30	Bolt	5	
19	TD50A-D-3517037	放气螺钉	Bolt	1	
20	TK6138	制动灯开关总成	Brake Switch	1	
21	CA141-3514032-01	活塞密封圈	Piston Seal Ring	1	
22	TD50A-D-3510100	排气盖总成	Cover	1	
23	XM-60-3510011	安装支架	Support	1	
24	TD50A-D-3510018	锁环	Lock Ring	1	
25	TD72LC-3510013	活塞限位圈	Piston Ring	1	
26	TD72LC-3510012	弹簧	Spring	1	
27	TD72LC-3510011	密封圈护圈	Ring	1	
28	TD72LC-3510010	皮圈	Rubber Bowel	1	
29	XM-60-3510012	平垫	Washer	1	
30	SD18 × 30 × 10	骨架橡胶油封	Skeleton Oil Seal	2	
31	XM-60-3510003	推杆	Push Rod	1	
32	GB893.1-86	孔用挡圈 25	Snap	1	
33	XM-60-3510106B	推杆座	Push Rod Seat	1	
34	XM-60-3510101B	液压活塞	Hydraulic Piston	1	
35	980S-3510116	进油阀门	Inlet Oil Valve	1	
36	XM-60-3510102B	皮圈	Rubber Bowel	1	

49. 切断气缸 Break Air Cylinder  
制动气缸 Brake Air Cylinder

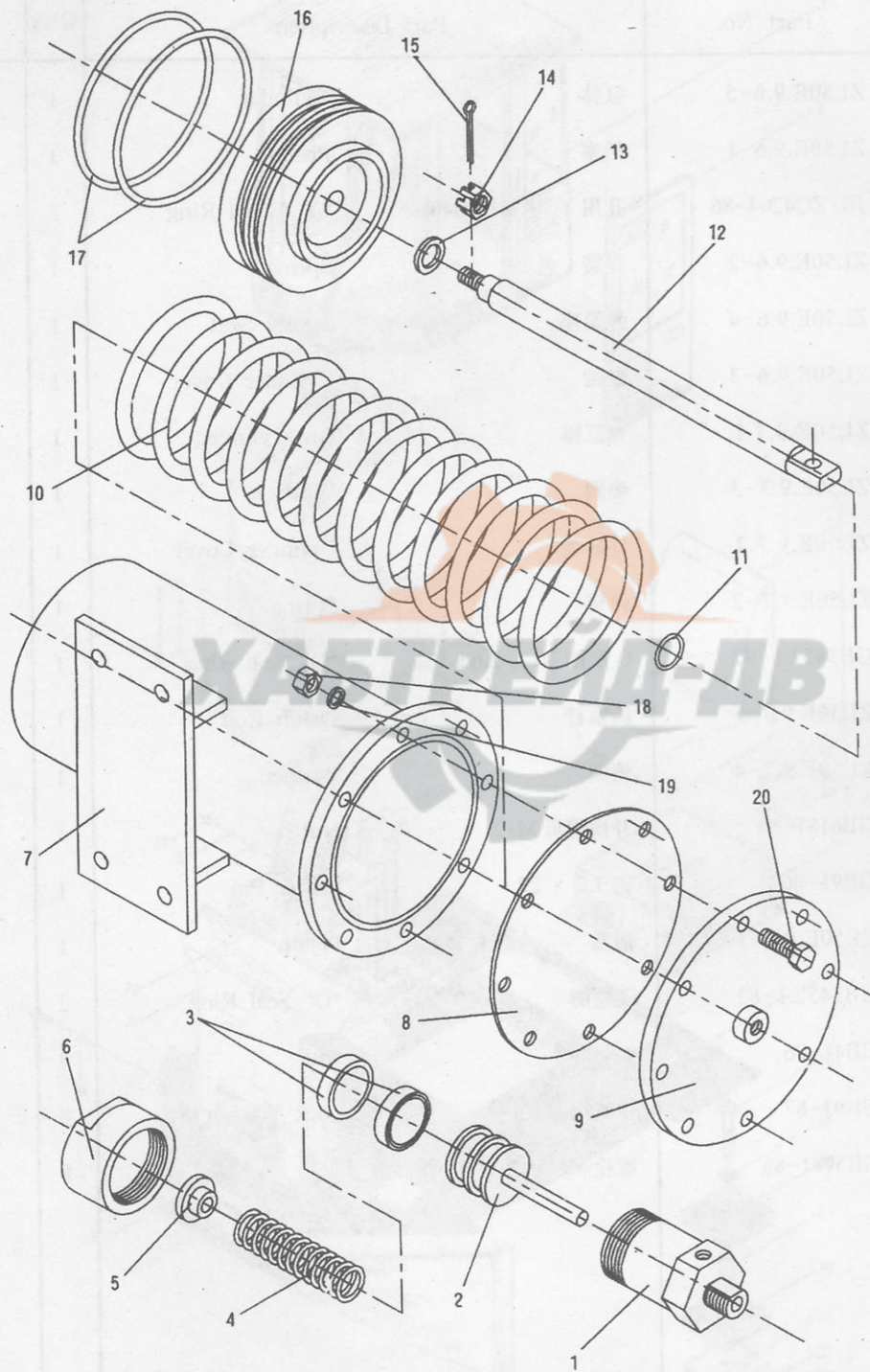



## 49. 切断气缸 Break Air Cylinder

## 制动气缸 Brake Air Cylinder

序号 Sr. No.	零件代号 Part No.	名 称 Part Description	数量 Q'ty	备 注 Remark
1	ZL50E.9.6-5	缸体 Cylinder	1	
2	ZL50E.9.6-1	活塞 Piston	1	
3	JB/ZQ4264-86	孔用 Y <sub>x</sub> 密封圈 D40 "Y <sub>x</sub> " Seal Ring	2	
4	ZL50E.9.6-2	弹簧 Spring	1	
5	ZL50E.9.6-4	弹簧座 Spring Seat	1	
6	ZL50E.9.6-3	缸盖 Cylinder Cover	1	
7	ZL50E.9.7.1	气缸体 Air Cylinder	1	
8	ZL50E.9.7-3	垫圈 Washer	1	
9	ZL50E.9.7.2	气缸盖 Cylinder Cover	1	
10	ZL50E.9.7-2	弹簧 Spring	1	
11	GB3452.1-92	O 型圈 20 × 2.65 "O" Seal Ring	1	
12	ZL50E.9.7-5	活塞杆 Piston Rod	1	
13	ZL50E.9.7-4	垫圈 Washer	1	
14	GB6181-86	开槽螺母 M12 Nut	1	
15	GB91-86	销 3.2 × 22 Cotter Pin	1	
16	ZL50E.9.7-1	活塞 Piston	1	
17	GB3452.1-82	O 型圈 "O" Seal Ring	2	
18	GB41-86	螺母 M8 Nut	8	
19	GB93-87	弹簧垫圈 8 Lock Washer	8	
20	GB5781-86	螺栓 M8 × 30 Bolt	8	

# 50. 驾驶室 Cab

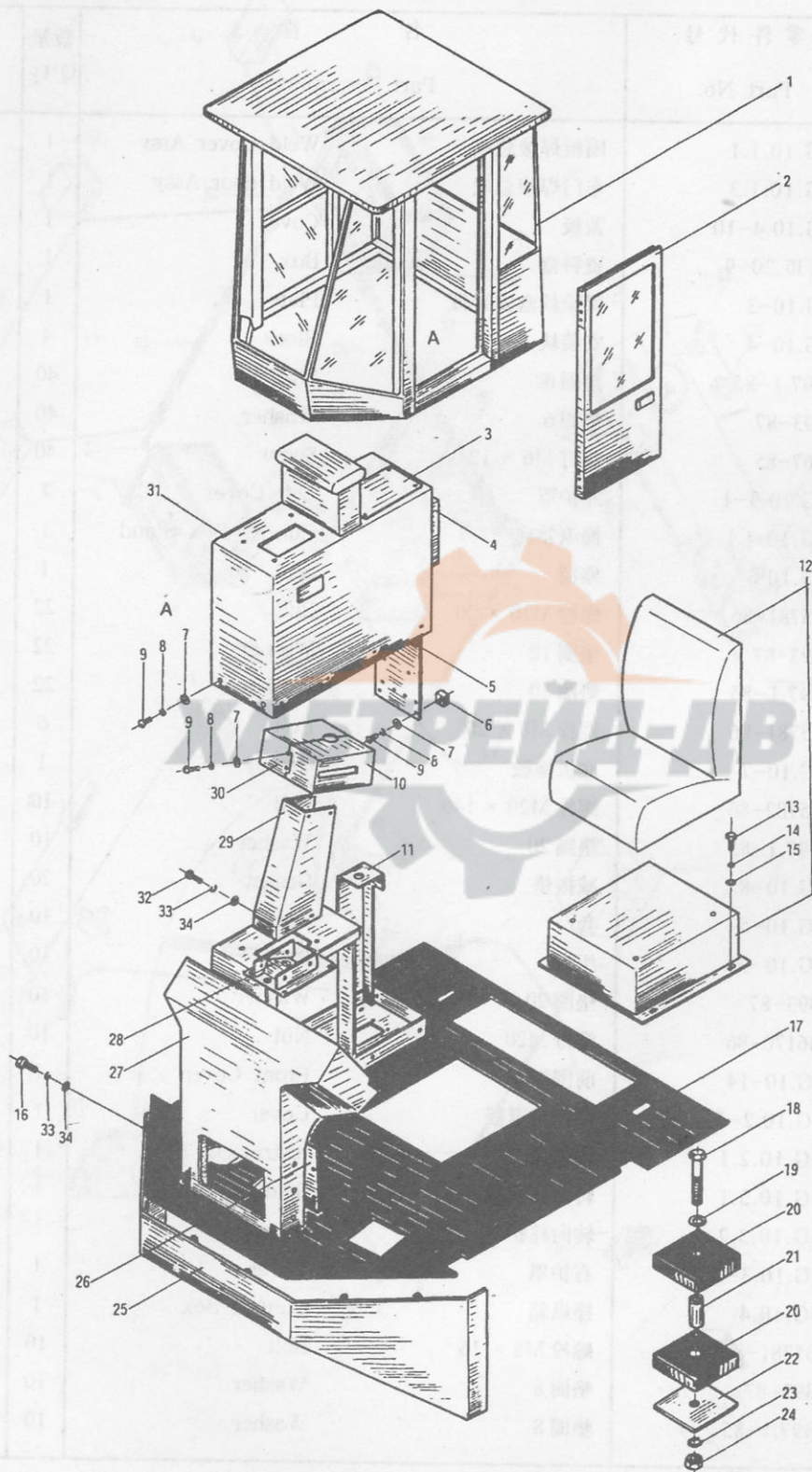



## 50.驾驶室 Cab

序号 Sr. No.	零件代号 Part No.	名 称 Part Description	数量 Q'ty	备注 Remark
1	Z5G.10.1.1	围板焊接总成	1	
2	Z5G.10.1.3	车门焊接总成	1	
3	Z5G.10.4-10	盖板	1	
4	85Z III.20-9	资料盒	1	
5	Z5G.10-3	保险丝盒安装板	1	
6	Z5G.10-4	安装块	4	
7	GB97.1-85	垫圈 6	40	
8	GB93-87	垫圈 6	40	
9	GB67-85	螺钉 M6 × 12	40	
10	Z5G.10.3-1	左护罩	1	
11	Z5G.10.4.1	操纵箱座	1	
12	Z5G.10.6	座椅	1	
13	GB5781-86	螺栓 M10 × 20	22	
14	GB93-87	垫圈 10	22	
15	GB97.1-85	垫圈 10	22	
16	GB5781-86	螺栓 M8 × 20	6	
17	Z5G.10-7	底板橡胶	1	
18	GB5782-86	螺栓 M20 × 140	10	
19	GB97.1-85	垫圈 20	10	
20	Z5G.10-8	减振垫	20	
21	Z5G.10-5	套	10	
22	Z5G.10-9	压板	10	
23	GB93-87	垫圈 20	10	
24	GB6170-86	螺母 M20	10	
25	Z5G.10-14	前围板	1	
26	Z5G.10.2-3	仪表箱罩板	1	
27	Z5G.10.2.1	仪表箱	1	
28	Z5G.10.3.1	转向柱底座	1	
29	Z5G.10.3.2	转向柱护罩	1	
30	Z5G.10.3-2	右护罩	1	
31	Z5G.10.4	操纵箱	1	
32	GB5781-86	螺栓 M8 × 16	10	
33	GB93-87	垫圈 8	10	
34	GB97.1-85	垫圈 8	10	

# 51.电气系统 Electrical System

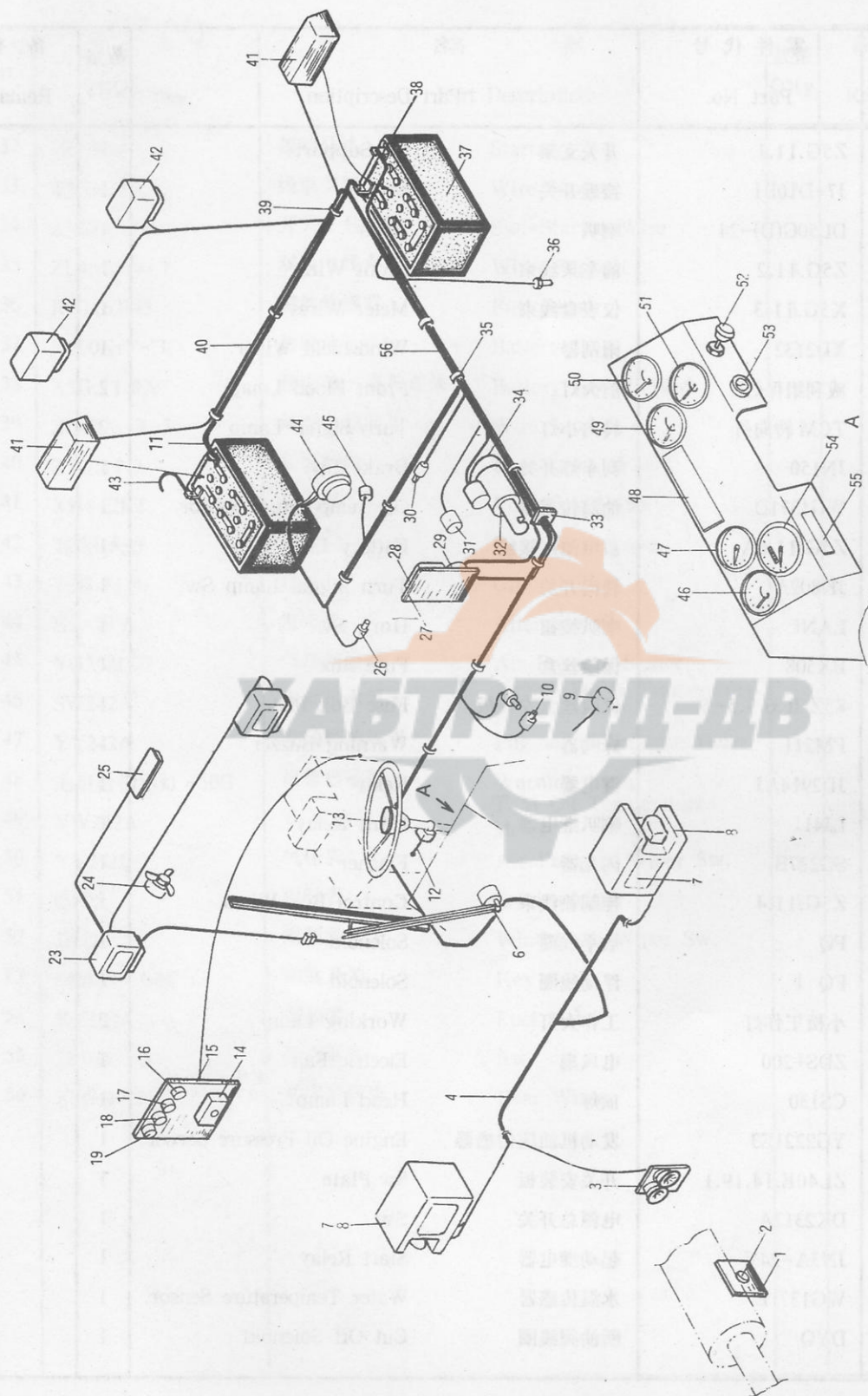



## 51.电气系统 Electrical System

序号 Sr. No.	零件代号 Part No.	名 称 Part Description		数量 Q'ty	备注 Remark
1	Z5G.11.1	开关支架	Sw.Support	1	
2	J7-D10B1	接近开关	Sw.	1	
3	DL50G(D)-24	喇叭	Horn	1	
4	Z5G.11.2	前车架线束	Front Wires	1	
5	X5G.11.3	仪表盘线束	Meter Wires	1	
6	XD2132	雨刮器	Windshield Wiper	1	
7	威利组保灯	前大灯	Front Flood Lmap	2	
8	TCM 转向灯	转向小灯	Turn Signal Lamp	2	
9	JN150	刹车灯开关	Brake Sw.	1	
10	WG1371D	油温传感器	Oil Temperature Sensor	1	
11	Z5G.11.6A	蓄电池连接线	Battery Link Wire	1	
12	JK802A	转向开关	Turn Signal Lamp Sw.	1	
13	LAN	喇叭按钮	Horn Sw.	1	
14	BX508	保险丝盒	Fuse Box	1	
15	85Z II.6.3.5-5	保险丝盒安装板	Fuse Box Plate	1	
16	FM211	蜂鸣器	Warning Buzzer	1	
17	JD2914AJ	继电器	Relay	1	
18	LJ41	喇叭继电器	Horn Relay	1	
19	SG227B	闪光器	Flasher	1	
20	Z5G.11.4	控制箱线束	Control Box Wires	1	
21	PQ	放平线圈	Solenoid	1	
22	FQ	浮动线圈	Solenoid	1	
23	小松工作灯	工作大灯	Working Lamp	2	
24	ZDS-200	电风扇	Electric Fan	1	
25	CS130	顶灯	Head Lamp	1	
26	YG2221E3	发动机油压传感器	Engine Oil Pressure Sensor	1	
27	ZL40E.14.19.1	开关安装板	Sw.Plate	1	
28	DK2312A	电源总开关	Sw.	1	
29	JN3A-24V	起动继电器	Start Relay	1	
30	WG1371E	水温传感器	Water Temperature Sensor	1	
31	DYQ	断油阀线圈	Cut Off Solenoid	1	

## 51.电气系统 Electrical System

序号 Sr. No.	零件代号 Part No.	名 称 Part Description	数量 Q'ty	备 注 Remark
32	KB-24	起动马达 Startor	1	
33	Z5G11.11	线束支架 Wire Support	2	
34	Z5G11.10A	开关-马达线 Sw.-Startor Wire	1	
35	ZL40A.14-1	双股电线夹片 Wires Support	8	
36	RG1163M3	燃油传感器 Fuel Sensor	1	
37	N200NrF- II	蓄电池 Battery	2	
38	Z5G.11.8A	蓄电池-开关连接线 Battery-Switch Wire	1	
39	ZL40A.14-3	单股电线夹片 Wire Support	17	
40	Z5G.11.7	后灯线束 Rear Lamp Wire	1	
41	XH8-2L2	后小灯 Rear Dim Lamp	2	
42	TCM 大灯	后大灯 Rear Work Lamp	2	
43	Z5G.11.5	搭铁线 Ground Wire	1	
44	K1-28V	发电机 Alternator	1	
45	YG2221C2	气压传感器 Air Pressure Sensor	1	
46	SW242A	发动机水温表 Engine Water Temperature Meter	1	
47	YY242A	发动机油压表 Engine Oil Pressure Meter	1	
48	七组合指示灯-50G	报警指示灯 Warning Lamp	1	
49	YW242A	T/M 油温表 T/M Oil Temperature Meter	1	
50	YY242C	气压表 Air Pressure Wiper Sw.	1	
51	QJT5	积时表 Service Meter	1	
52	JK114	雨刮器开关 Windshield Wiper Sw.	1	
53	08086-10000	钥匙开关 Key Sw.	1	
54	RY242A	燃油表 Fuel Meter	1	
55	JK932-50G	组合开关 Sw.	1	
56	Z5G.11.9	后车架线束 Rear Wires	1	



# 52. 机罩 Engine Hood

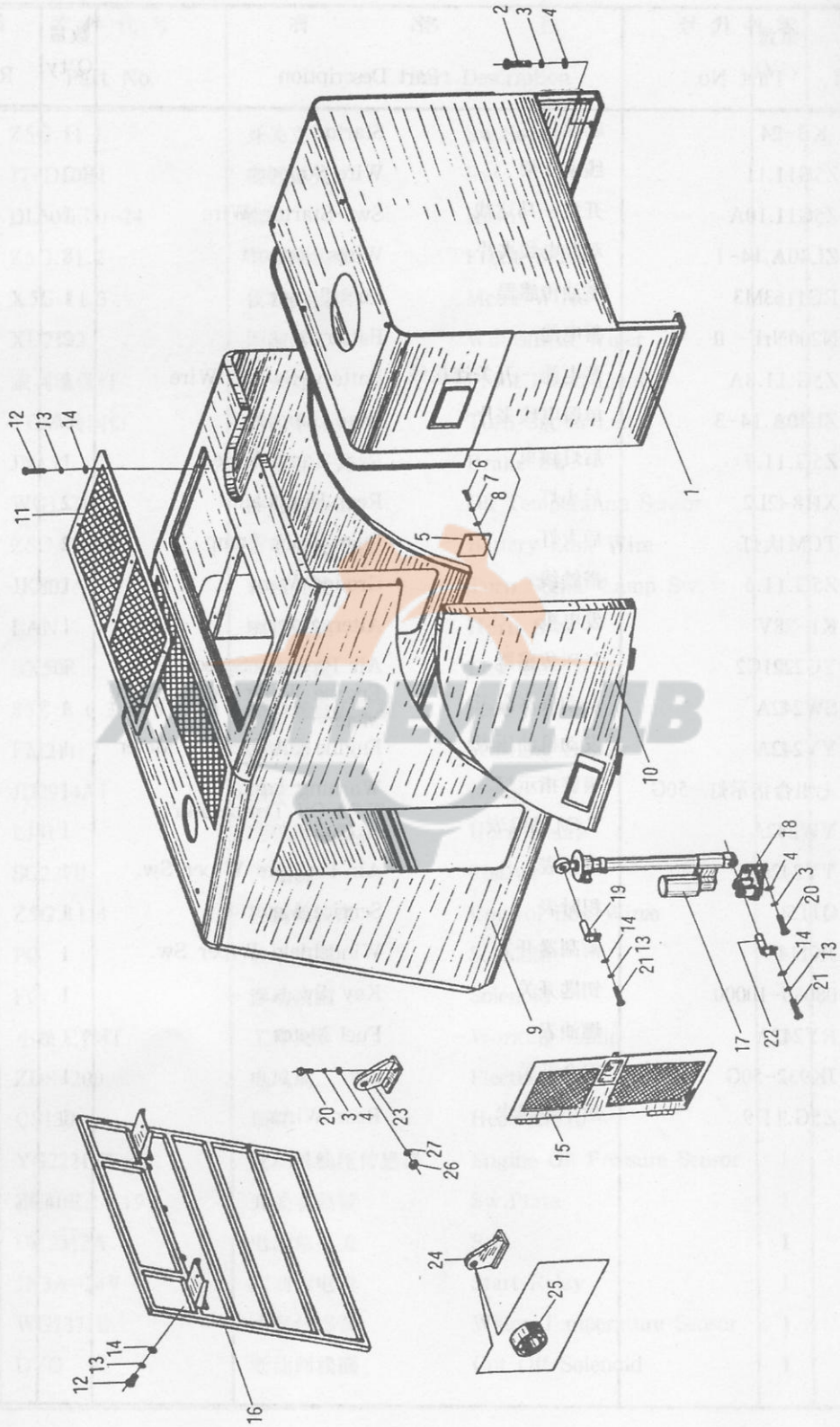

## 52.机罩 Engine Hood

序号 Sr. No.	零件代号 Part No.	名 称 Part Description		数量 Q'ty	备注 Remark
1	Z5G(V).12.3	前罩	Front Hood	1	
2	GB5781-86	螺栓 M12 × 25	Bolt	4	
3	GB93-87	垫圈 12	Lock Washer	11	
4	GB97.1-85	垫圈 12	Washer	11	
5	Z5G.12.3-21	锁板	Lock Plate	2	
6	GB5781-86	螺栓 M8 × 25	Bolt	4	
7	GB93-87	垫圈 8	Lock Washer	4	
8	GB97.1-87	垫圈 8	Washer	4	
9	Z5G(V).12.1	后罩	Rear Hood	1	
10	Z5G.12.2	侧罩	Side Hood	2	
11	Z5G(V).12.1-1	上盖板	Cover Plate	1	
12	GB5783-86	螺栓 M10 × 35	Bolt	12	
13	GB93-87	垫圈 10	Lock Washer	14	
14	GB97.1-85	垫圈 10	Washer	14	
15	Z4G.8.1.1	门	Door	2	
16	Z5G.12.4	后挡罩	Rear Hood	1	
17	526G.12.2A	电控举升机构	Lift Drive	1	
18	Z4G.8.8	缸左支座	Stand	1	
19	Z5G.12.12	上销轴	Pin	1	
20	GB5781-86	螺栓 M12 × 30	Bolt	7	
21	GB5783-86	螺栓 M10 × 20	Bolt	2	
22	Z5G.12.11	下销轴	Pin	1	
23	Z5G.12.7	罩左支座	Left Plate	1	
24	Z5G.12.6	罩右支座	Right Plate	1	
25	GB/T276-94	球轴承 61904	Ball Bearing	2	
26	GB6170-86	螺母 M16	Nut	2	
27	GB95-85	垫圈 16	Lock Washer	2	



# 53. 空调系统 Air Conditioner

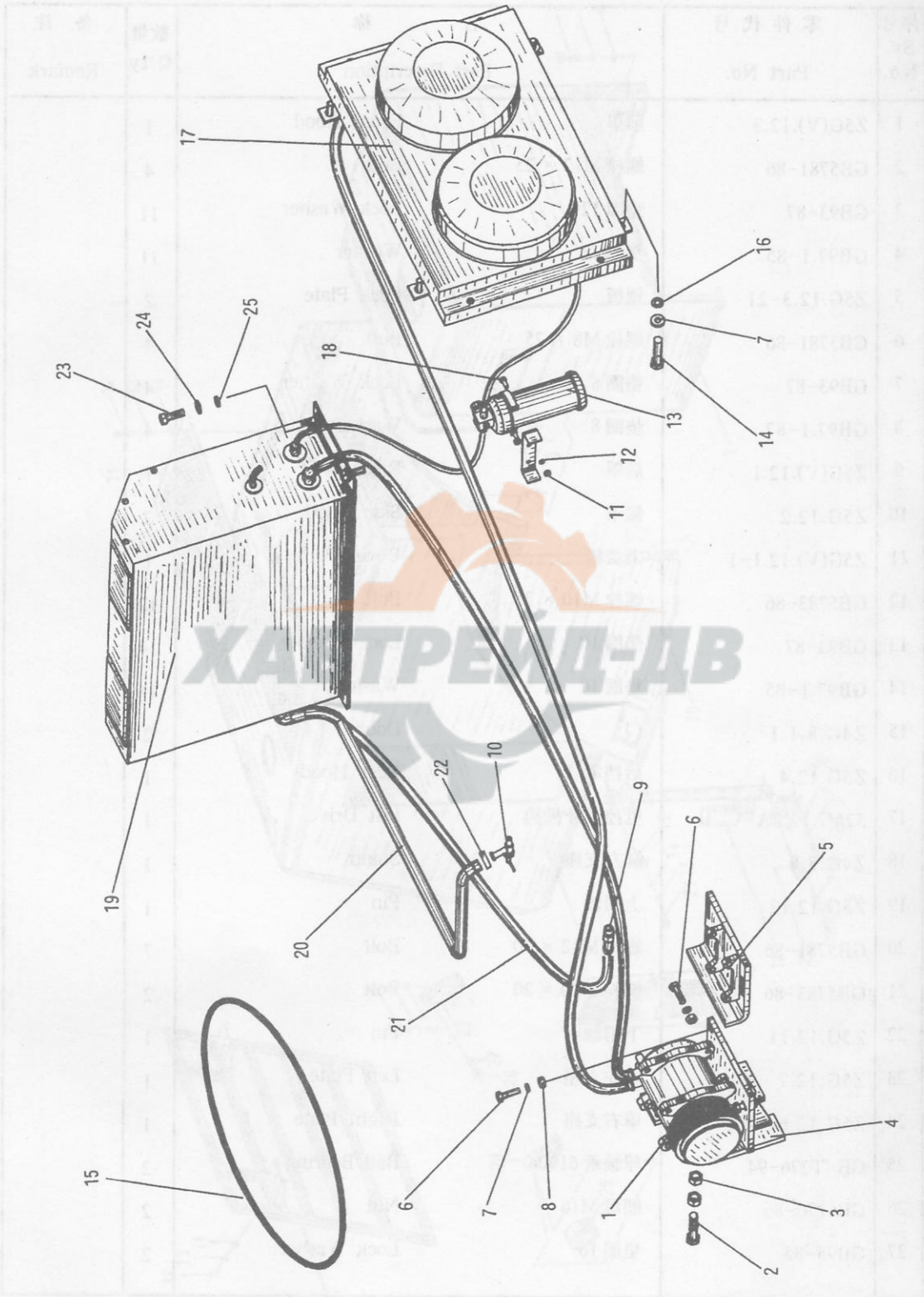

## 53.空调系统 Air Conditioner

序号 Sr. No.	零件代号 Part No.	名 称 Part Description		数量 Q'ty	备注 Remark
1		空调压缩机	Air-Condition Compressor	1	空调总成 (Z5G.14.2)带
2	GB5783-86	螺栓 M14 × 65	Bolt	1	
3	GB6170-86	螺母 M14	Nut	2	
4	Z5G.14.1.1	下支架	Lower Bracket	1	
5	Z5G.14.1.2	上支架	Upper Bracket	1	
6	GB5783-86	螺栓 M10 × 35	Bolt	7	
7	GB93-87	垫圈 10	Washer	11	
8	GB6170-86	螺母 M10	Nut	7	
9	ZL40A.15.3-5	接头	Joint	1	
10	ZL50.26.5	暖风热水开关 (Z3/8)	Switch	1	
11	GB6170-86	螺母 M6	Nut	2	
12	GB93-87	垫圈 6	Washer	2	
13		储液罐	Liquid-Tank	1	空调总成 (Z5G.14.2)带
14	GB5783-86	螺栓 M10 × 25	Bolt	4	
15		A 型皮带 17-510	"A" Strap	1	空调总成 (Z5G.14.2)带
16	Z4G.11-3	垫块	Block	4	
17		冷凝器	Condenser	1	空调总成 (Z5G.14.2)带
18	GB5781-86	螺栓 M6 × 16	Bolt	2	
19		蒸发器	Evaporator	1	空调总成 (Z5G.14.2)带
20	Z5G.14-1	暖水水管	Water Pipe	1	输水胶管 F 16
21	Z5G.14-2	暖水水管	Water Pipe	1	输水胶管 F 16
22	JB3616.1-84	双钢丝喉箍 20-24	Double Steel Wir Clamp	4	
23	GB5783-86	螺栓 M12 × 35	Bolt	4	
24	GB93-87	垫圈 12	Washer	4	
25	GB97.1-85	垫圈 12	Washer	4	